

Granterra

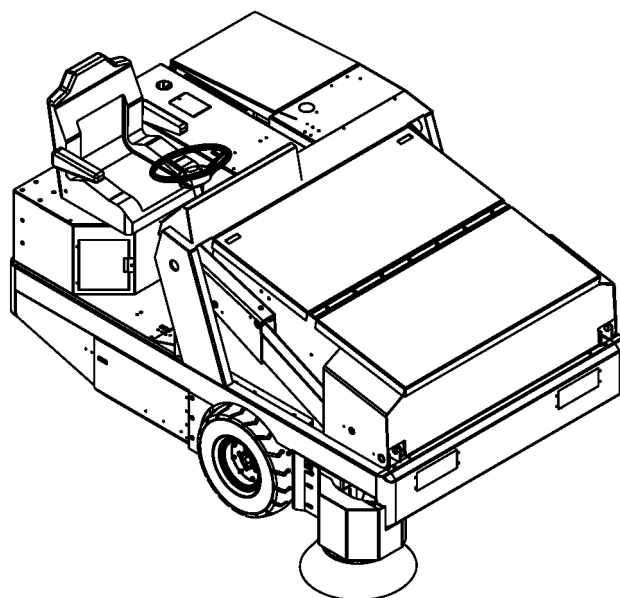

PARTS LIST

Active Models: 56516905(LPG), 56516906(Diesel)

Obsolete Models: 56516904(Gas)

DESCRIPTION	PAGE
Lower Body System	4-5
Main Broom Assembly	6-7
Main Broom Lift Mechanism.....	8-9
Side Broom Assembly.....	10-11
Operator Compartment	12-13
Control Panel & Horn	14-15
Hopper System - 1	16
Hopper System – 2	17
Hopper System – 3	18-19
Hopper Lift System.....	20-21
Steering Gear & Rear Drive System	22-23
Forward/Reverse Assembly (Gasoline/LPG/Diesel)	24-25
Forward/Reverse Control (Gasoline & LPG Only)	26-29
Forward/Reverse Control (Diesel Only)	30-31
Front Wheel & Brake Assembly	32-33
Brake Control Linkage.....	34-35
Impeller & Fittings	36-37
Control Valve & Fittings.....	38-39
Main Broom Motor & Fittings.....	40-41
Side Broom Motor & Fittings	42
Lift, Rotation & Dump Cylinders w/ Fittings.....	43
Lift Cylinder Lock-out Valve & Fittings.....	44
Auxiliary Manifold & Fittings	45
Return Manifold Assembly	46-47
Hydraulic Reservoir & Fittings.....	48-49
Engine Cover	50-51
Engine Access Door.....	52-53
GM 3.0 Liter - Gas & LP Engines [Mounting Brackets] IMPCO	54-55
GM 3.0 Liter - Gas & LP Engines [Mounting Brackets] PSI	56-57
GM 3.0 Liter - Gas Engine [Fan, Air Intake & Radiator Hoses].....	58-59
GM 3.0 Liter - LP Engine [Fan, Air Intake & Radiator Hoses] IMPCO	60-61
GM 3.0 Liter - LP Engine [Fan, Air Intake & Radiator Hoses] PSI	62-63
GM 3.0 Liter - Gas & LP Engines [Exhaust System].....	64-65
GM 3.0 Liter - Gas Engine (Fuel System).....	66-69
Radiator Assy - GM 3.0 Liter Engine [Gasoline & LPG]	70-71
LP Tank System	72-73
Air Cleaner Assy [Gasoline, LPG, Diesel]	74-75
Mitsubishi S4Q2 Tier 4 - Diesel Engine [Fan, Brackets, Throttle].....	76-77
Mitsubishi S4Q2 Tier 4 - Diesel Engine [Exhaust System].....	78-79
Mitsubishi S4Q2 Tier 4 - Diesel Engine [Fuel System].....	80-81
Radiator Assy [Diesel].....	82-83
Fuel Tank (Diesel)	84-85
Decals	86-87
Instrument Panel.....	88-89
Hydraulic Hose System.....	90-93
Harness Routing (Gasoline/LPG/Diesel).....	94-95
Wiring Diagram	96
Broom Selector Guide.....	97

WHEN ORDERING PARTS

- * Use the part numbers from the "Ref. No." columns in this parts list.
- * Specify the model and serial number of the machine.
- * Use the space below to record the model and serial number for future reference.

Model _____ Serial No. _____

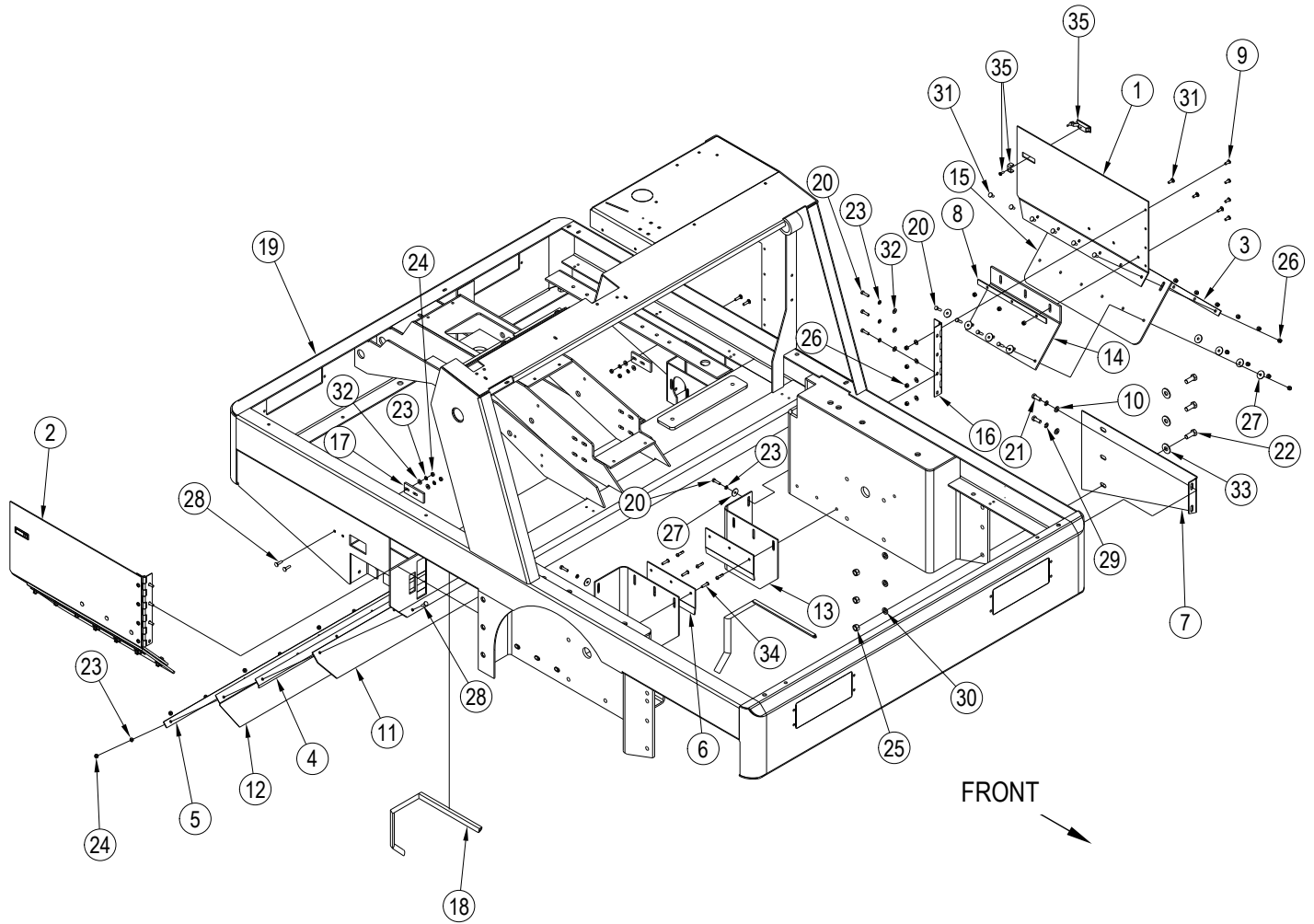

09-5

LOWER BODY SYSTEM

12-10

Granterra

5

Item	Ref. No.	Qty	Description
1	56516779	1	Door Lh Broom
2	56516780	1	Door Rh Broom
3	56516781	2	Clamp Broom Door Flap Outer
4	56516782	1	Clamp Rear Flap Brm Cham Inner
5	56516783	1	Clamp-Brm Chmbr Rear Flap
6	56516784	2	Clamp-Wheel Well Flap
7	56516785	1	Panel-Lh Side Broom
8	56516786	2	Clamp Broom Door Flap Inner
9	2-00-00078	8	Screw-Ph.Rhm .25-20 X .63
10	2-00-00402	2	Washer, 25/64" Id X 3/4" Od
11	8-25-08172	1	Flap-Frame-Rear Inside
12	8-25-08173	1	Flap-Brm Chmbr Rear .06 Tk
13	8-25-08174	2	Flap-Wheel Well
14	8-25-08184	2	Flap-Broom Door Inner
15	8-25-08185	2	Flap-Broom Door Outer
16	8-32-00043	2	Hinge-Broom Door Plated
17	8-41-00047	2	Latch Tab
18	8-68-05073	2	Seal Main Broom Chamber
19		1	Frame Weldment (not available for sale)
20	2-00-00205	16	Bolt-Hex Head, Finished, 1/4-20
21	2-00-00233	2	Bolt-Hex Head, Finished, 3/8-16 X 1.00
22	2-00-00240	3	Screw, 1/2-13 X 1.250 Hhc
23	2-00-00518	17	Washer,Lock,1/4" Helical Spring
24	2-00-00594	9	Nut, Hex 1/4-20
25	2-00-00596	3	Nut, Hex Head, 1/2-13 X .44 Lg
26	2-00-00641	34	Nut, Fiber Insert 1/4-20
27	2-00-01676	18	Wshr-Flat, 1.063x.266x.063 Stl.
28	2-00-02196	9	1/4-20-1 Lg Carriage Bolt
29	2-00-02310	2	Washer-Lock, 3/8", Helical Spring
30	2-00-02312	3	Washer, 1/2" Lock
31	2-00-03575	18	Bolt-Carr, .25-20 X .75 Gr5 Zn
32	2-00-03702	18	Washer, .625 X .281 X .063
33	2-00-04159	3	Washer, Flat 1-3/8 X 9/16 X 7/64
34	2-00-04877	6	Screw- 1/4-20 X 1.00 Bhs W/ Nylok
35	7-41-00065	2	Latch

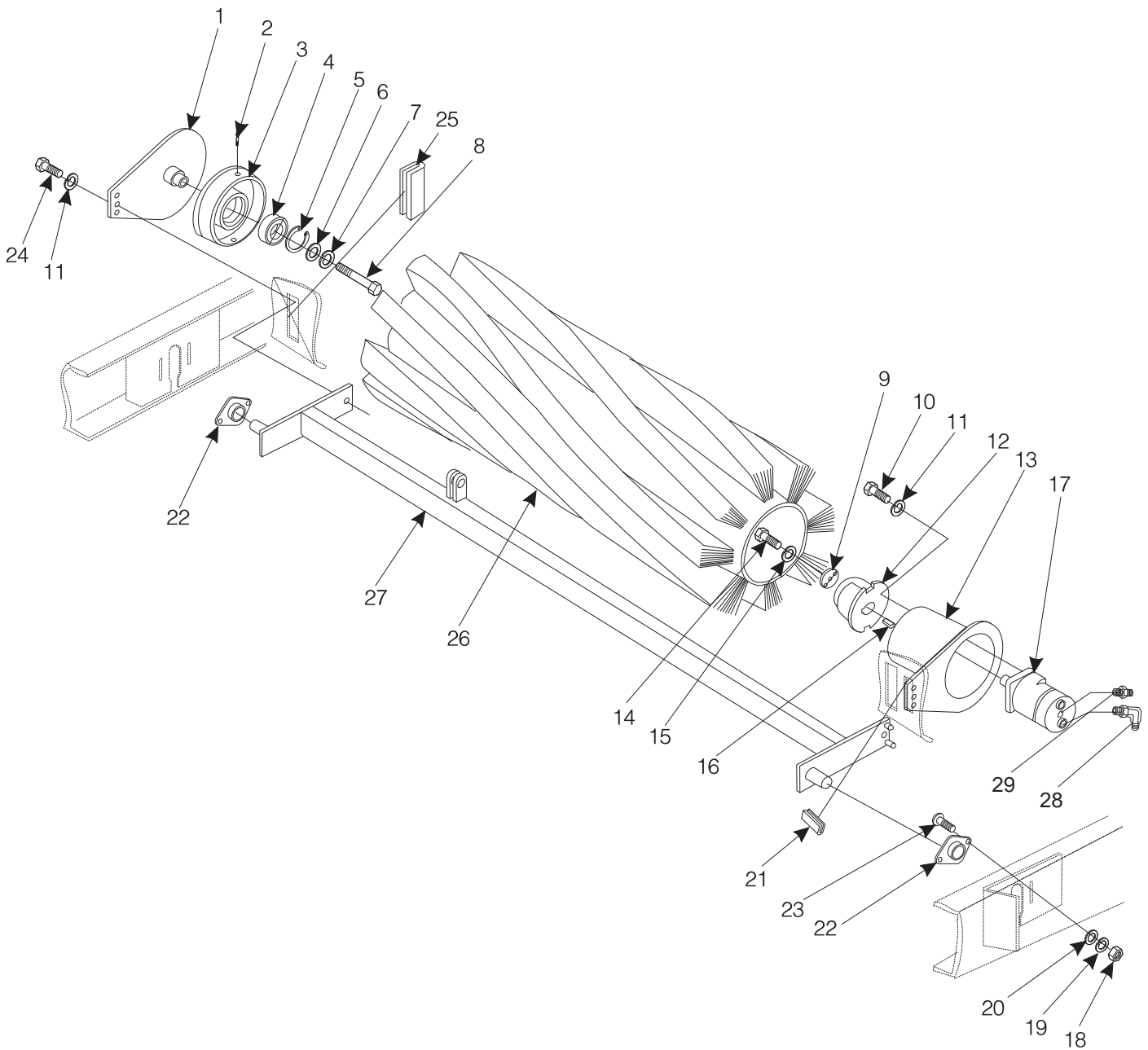

Item	Ref. No.	Qty	Description
1	8-16-00039	1	Broom Arm Weldment
2	2-00-04886	2	Screw, 3/8-16 x 1/2 HSHC
3	8-33-09090	1	Idle, Main Broom
4	2-00-04889	1	Ball Bearing
5	2-00-04890	1	Retaining Ring, 2.437 Int.
6	8-75-01157	1	Flat Washer, 3/4
7	2-00-00522	1	Lock Washer, 3/4 Helical Spring
8	2-00-04887	1	Screw, 3/4-10 x 1.25 HHC
9	8-58-05160	1	Plate, Locking Hub
10	2-00-00232	4	Screw, 3/8-16 x 3/4 HHC
11	2-00-02310	6	Lock Washer, 3/8 Helical Spring
12	8-33-09046-1	1	Drive Hub
13	8-16-00041	1	Arm, Drive Broom
14	2-00-03039	3	Screw, 1/4-20 x .625 HSHC
15	2-00-00518	6	Lock Washer, 1/4 Helical Spring
16	2-00-00722	1	Woodruff Key, 1/4 x 1 (#15)
17	0882-040	1	Hydraulic Motor
18	2-00-00585	4	Nut, Hex 5/16-18 x .500 x .265
19	2-00-00530	4	Lock Washer, 5/16 Helical Spring
20	2-00-00409	4	Flat Washer, .687 x .343 x .062
21	8-21-04048	2	Edging
22	2-00-03997	2	Flange Bearing, 3.750 x 1.0
23	2-00-00196	4	Carriage Bolt, 5/16-18 x 1.0
24	2-00-00233	2	Screw, 3/8-16 x 1.0 HHC
25	8-29-00220	4	Gasket, Broom Chamber
26	REF	1	Main Broom (see Broom Selector Guide)
27	8-03-04281	1	Lift Frame, Main Broom
28	2-00-04885	1	Elbow Fitting - 90° St. Thd.
29	2-00-04895	1	Straight Fitting - SAE #4 to ORS #4

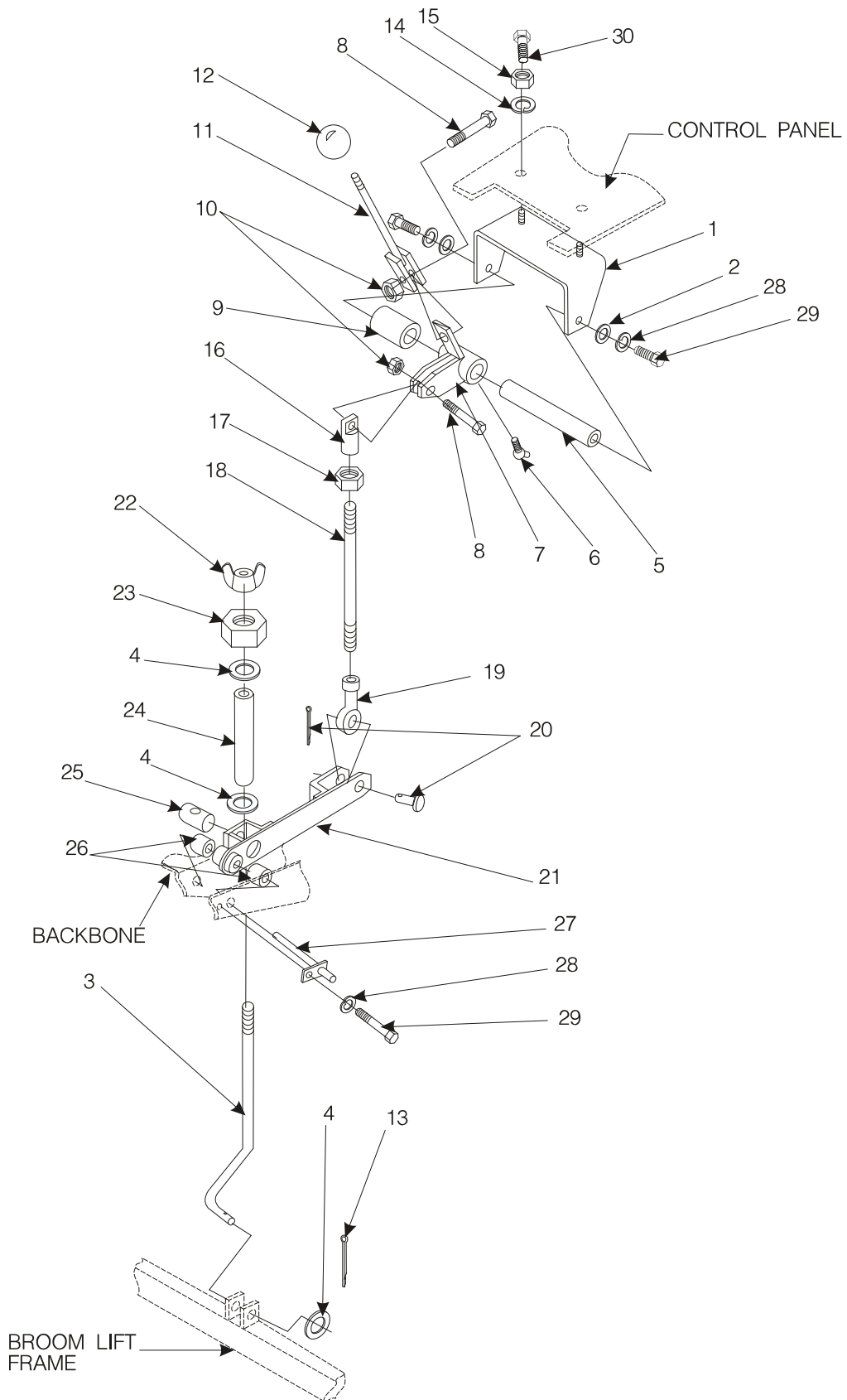

Item	Ref. No.	Qty	Description
1	8-08-00645	1	Bracket, Main Broom Pivot
3	8-66-00161	1	Rod, Linkage (Main Broom)
4	2-00-00432	3	Flat Washer, 3/4 I.D.
5	8-70-05284	1	Shaft
6	2-00-02558	1	Lubrication Fitting, 45° 1/8 NPT
7	8-16-00035	1	Pivot Block
8	2-00-00234	2	Screw, 3/8-16 x 1.50 HHC
9	8-75-01177	1	Pivot Tube Spacer
10	2-95-04182	2	Nut, 3/8-16 Fiber Insert Hex
11	8-16-00034	1	Lever
12	8-39-00003	1	Knob
13	2-00-02436	1	Cotter Pin, 1.500 x 1.875
14	2-00-00530	2	Lock Washer, 5/16 Helical Spring
15	2-00-00585	1	Nut, 5/16-18 x .500 x .265 Hex
16	8-66-00141	1	Rod End
17	2-00-00591	1	Nut, 1/2-20 x .750 x .312 Hex Jam
18	8-66-00150	1	Rod, Control Rod Lift Linkage
19	8-66-00144	1	"MPB" Rod End # WF-8-32
20	8-55-08101	1	Clevis Pin #1/2-1.75 - E&E
21	8-16-00037	1	Lift Linkage
22	2-00-04891	1	Wing Nut, 3/4-10 Thread
23	8-39-00011	1	Torque Knob
24	8-75-01180	1	Spacer
25	8-55-08099	1	Pivot Pin
26	8-75-01178	2	Spacer, .78 x .97
27	8-16-00038	1	Pivot Shaft
28	2-00-00518	3	Lock Washer, 1/4 Helical Spring
29	2-00-00221	3	Screw, 1/4-20 x 3/4 HHC
30	2-00-00208	2	Screw, 5/16-18 x 3/4

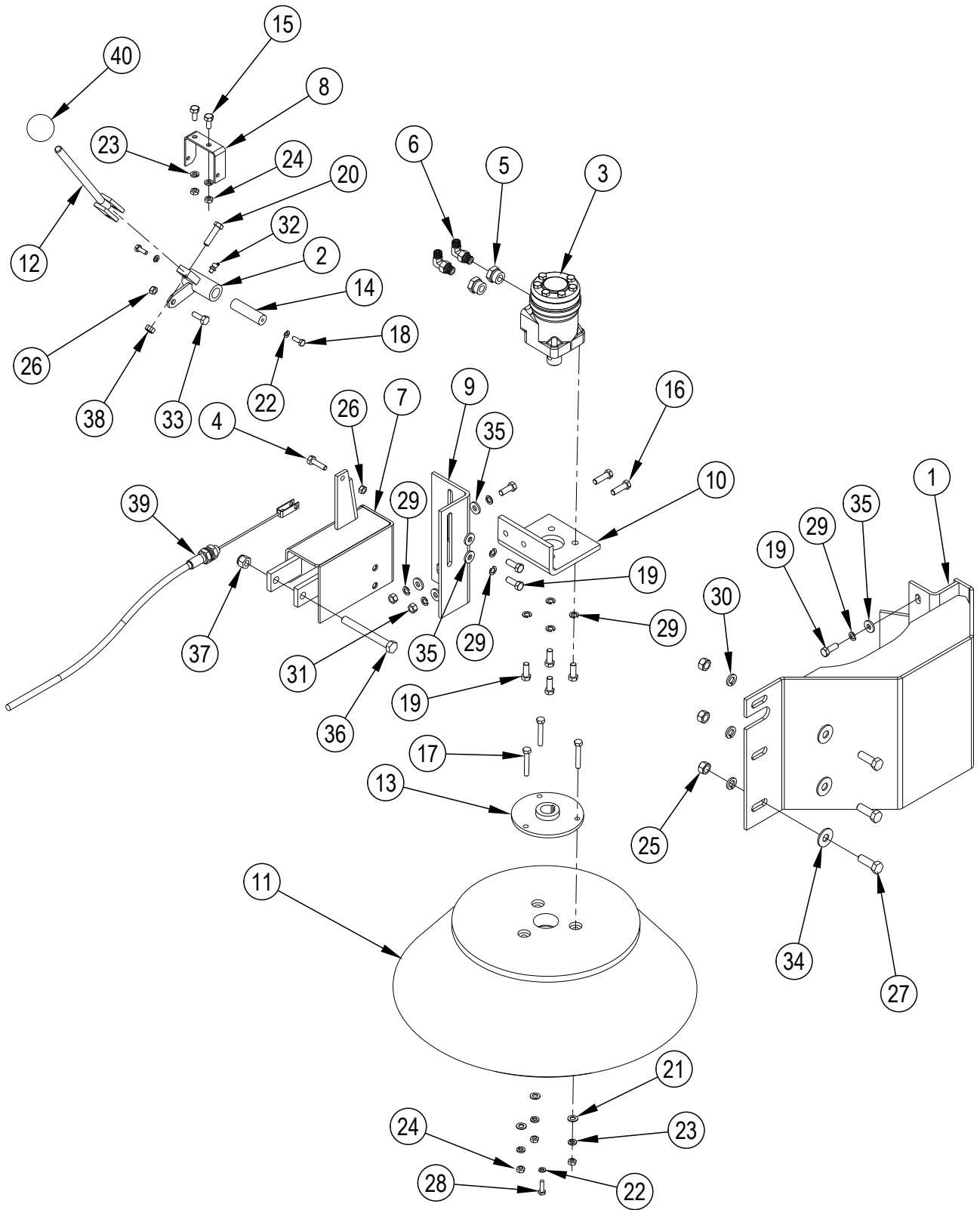

Item	Ref. No.	Qty	Description
1	56516809	1	Weldt, Side Broom Guard
2	56516810	1	Pivot-Side Broom
3	0882-047	1	Side Broom Motor
4	2-00-00207	1	Screw, Hex Head 5/16-18 X 1.25"
5	2-00-04915	2	Fitting-Reducer Sae 10 / Sae 6
6	2-00-04926	2	Fitting-90 Sae6 To Ors4
7	8-03-04282	1	Weldt-Side Broom Arm Rh
8	8-08-00646	1	Bracket-Side Broom Pivot
9	8-08-00725	1	Bracket-Side Brm Lift Arm
10	8-08-00726	1	Bracket-Side Broom Lift Arm
11	8-08-03211	1	Side Broom-Nylon
12	8-16-00034	1	Broom Lift Lever
13	8-25-06008	1	Flange-Curb Broom
14	8-70-05285	1	Shaft-Side Broom Pivot
15	2-00-00208	2	Screw, 5/16-18 X .750 Hhc
16	2-00-00209	2	Bolt, Hex Head, 3/8-16 X 1 1/4 Ss
17	2-00-00218	3	Bolt-Hex Head, 5/16-18
18	2-00-00221	2	Bolt-Hex Head, Finished, 1/4-20x3/4 Lg
19	2-00-00233	9	Bolt-Hex Head, Finished, 3/8-16 X 1.00
20	2-00-00234	1	Screw, 3/8-16 X 1-1/2 Hhc
21	2-00-00409	3	Flat Washer, .687 X .344 X .062
22	2-00-00518	3	Washer,Lock,1/4" Helical Spring
23	2-00-00530	5	5/16" Lock Washer
24	2-00-00585	5	5/16-18, Hex Nut
25	2-00-00596	3	Nut, Hex Head, 1/2-13 X .44 Lg
26	2-00-00644	2	Nut, Hex, Insert Fiber, 5/16-18
27	2-00-01254	3	Screw, Hex, 1/2-13 X 1.50
28	2-00-01490	1	1/4-20 X 0.875", Hex Head Screw
29	2-00-02310	11	Washer-Lock, 3/8", Helical Spring
30	2-00-02312	3	Washer, 1/2" Lock
31	2-00-02360	2	Nut, Hex, 3/8-16
32	2-00-02558	1	Grease Fitting
33	2-00-02708	1	Screw, Hex Head, 5/16-18 X 1.00"
34	2-00-04159	3	Washer, Flat 1-3/8 X 9/16 X 7/64
35	2-00-04801	7	Flat Washer, 1.00 X .39 X .06
36	2-00-04914	1	Screw 1/2-13 X 4.5" Lg
37	2-00-04936	1	Locknut-Elastic, 1/2-13
38	2-95-04182	1	Nut, Hex, Stop, 3/8-16
39	8-10-00028	1	Cable-Fwd / Rev
40	8-39-00003	1	Knob

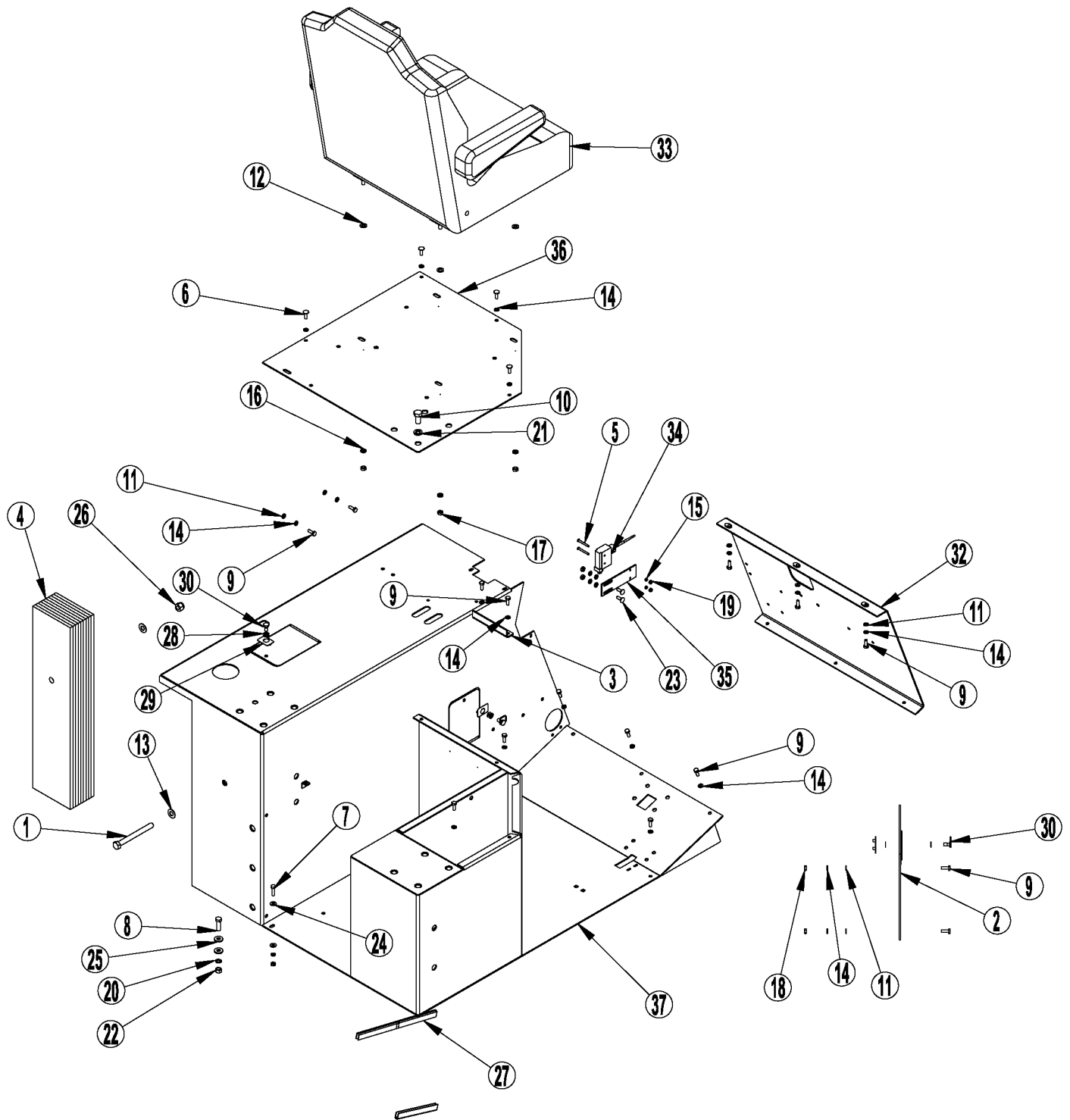

Item	Ref. No.	Qty	Description
1	56003282	1	Scr, Hex 1/2-13 X 5.00 Grade 8
2	56516791	1	Battery Door
3	56516793	1	Bracket-Battery Hold Down
4	56516794	9	Weight
5	2-00-00090	2	Screw, #8-32 X 1.50 Lg, Rhm
6	2-00-00183	4	Screw, 1/4-20, Round Head
7	2-00-00205	1	Bolt-Hex Head, Finished, 1/4-20
8	2-00-00209	1	Bolt, Hex Head, 3/8-16 X 1 1/4 Ss
9	2-00-00221	15	Bolt-Hex Head, Finished, 1/4-20x3/4 Lg
10	2-00-00239	1	Screw, 1/2-13 X 1.000 Hhc
11	2-00-00407	9	Washer, Flat 1/4
12	2-00-00409	4	Flat Washer, .687 X .344 X .062
13	2-00-00427	2	Washer, .50 Id X 1.0 Od X .06
14	2-00-00518	22	Washer,Lock, 1/4" Helical Spring
15	2-00-00529	2	Washer, #8 Lock
16	2-00-00530	4	5/16" Lock Washer
17	2-00-00585	4	5/16-18, Hex Nut
18	2-00-00594	5	Nut, Hex 1/4-20
19	2-00-00602	2	Hex Nut
20	2-00-02310	1	Washer-Lock, 3/8", Helical Spring
21	2-00-02312	1	Washer, 1/2" Lock
22	2-00-02360	1	Nut, Hex, 3/8-16
23	2-00-03575	2	Bolt-Carr, .25-20 X .75 Gr5 Zn
24	2-00-03702	2	Washer, .625 X .281 X .063
25	2-00-04801	2	Flat Washer, 1.00 X .39 X .06
26	2-00-04936	1	Locknut-Elastic, 1/2-13
27	7-21-04031	3	Edging-Brush Drive Support
28	7-23-03106	6	Washer-Screw-Captivated
29	7-23-03108	3	U Clip-Screw-Captivated
30	7-23-03113	3	Fastener, Qtr. Turn
31	8-27-07118	1	Frame
32	56516795	1	Kick Wall Weldment
33	8-69-00019	1	Seat- Suspension
[]	8-03-04320	1	Arm Rest Kit (RH + LH)
34	8-82-00058	1	Switch
35	56516789	1	Bracket, Hopper Switch
36	56516790	1	Panel, Seat Deck
37	56516792	1	Weldmt-1pc Drive Comp
[]	8-13-07068	2	Clip
[]	2-00-00686	1	Wrench, 3/4-9/16
[]	2-00-03061	2	Screw, #10-24 x 1/2 THM
[]	2-00-00605	2	Nut, Hex MS #10-24 x .375 x .125
[]	2-00-00519	2	Lock Washer, #10 Helical Spring

[] = Not Shown

Item	Ref. No.	Qty	Description
1#	56383106	1	Plate-Face Instrument Comp
2#	56493149	1	Plug, Cap (Diesel)
3#	56516825	1	Instrument Housing
4#	56516829	1	Backing Plate Brush Control
5#	56516830	1	Bracket (Diesel)
6#	2-00-00221	9	Scw-Hhc .25-20 X .75 Gr 8 Zn (qty of 6 on Gasoline & LPG)
7#	8-08-00735	1	Bracket Throttle Cable (Diesel)
8#	8-32-09013	1	Horn
9#	8-41-05074	1	Lever-Throttle Control Weldt (Diesel)
10#	56516827	1	Face Plate Main Broom Ctrl (Diesel)
#	56516828	1	Face Plate, MB Control/Throttle (Gasoline & LPG)
11#	2-00-00501	1	Washer .25 ID X .44 OD X .046
12#	2-00-00518	3	Washer, Lock, 1/4" Helical Spring (Diesel)
13#	2-00-00633	1	Nut, Fiber Insert 1/4-28 (Diesel)
14#	2-00-00641	6	Nut, Fiber Insert 1/4-20
15#	2-00-01246	8	Nut-#10-24 Elastic Stop Nut (qty of 4 on Gasoline & LPG)
16#	2-00-03061	8	Screw, #10-24 X .5 Truss Head (qty of 4 on Gasoline & LPG)
17#	2-00-03466	11	Screw #10-16x1/2 Self Tapping
18#	2-00-03702	9	Washer, .625 X .281 X .063 (qty of 8 on Gasoline & LPG)
19#	7-14-07006	1	Clevis (Diesel)
20#	7-25-02050	1	Rod End-Spherco (Diesel)
21#	7-39-00017	1	Knob-Solution Control (Diesel)
22#	8-13-07094	1	Conduit Clamp (Diesel)
23#	8-82-00074	1	Switch Body & Actuator-1 piece (Gasoline & LPG)
24#	7-11-04080	1	Check Engine Light (MIL) (Gasoline & LPG)

= Revised or new since last update

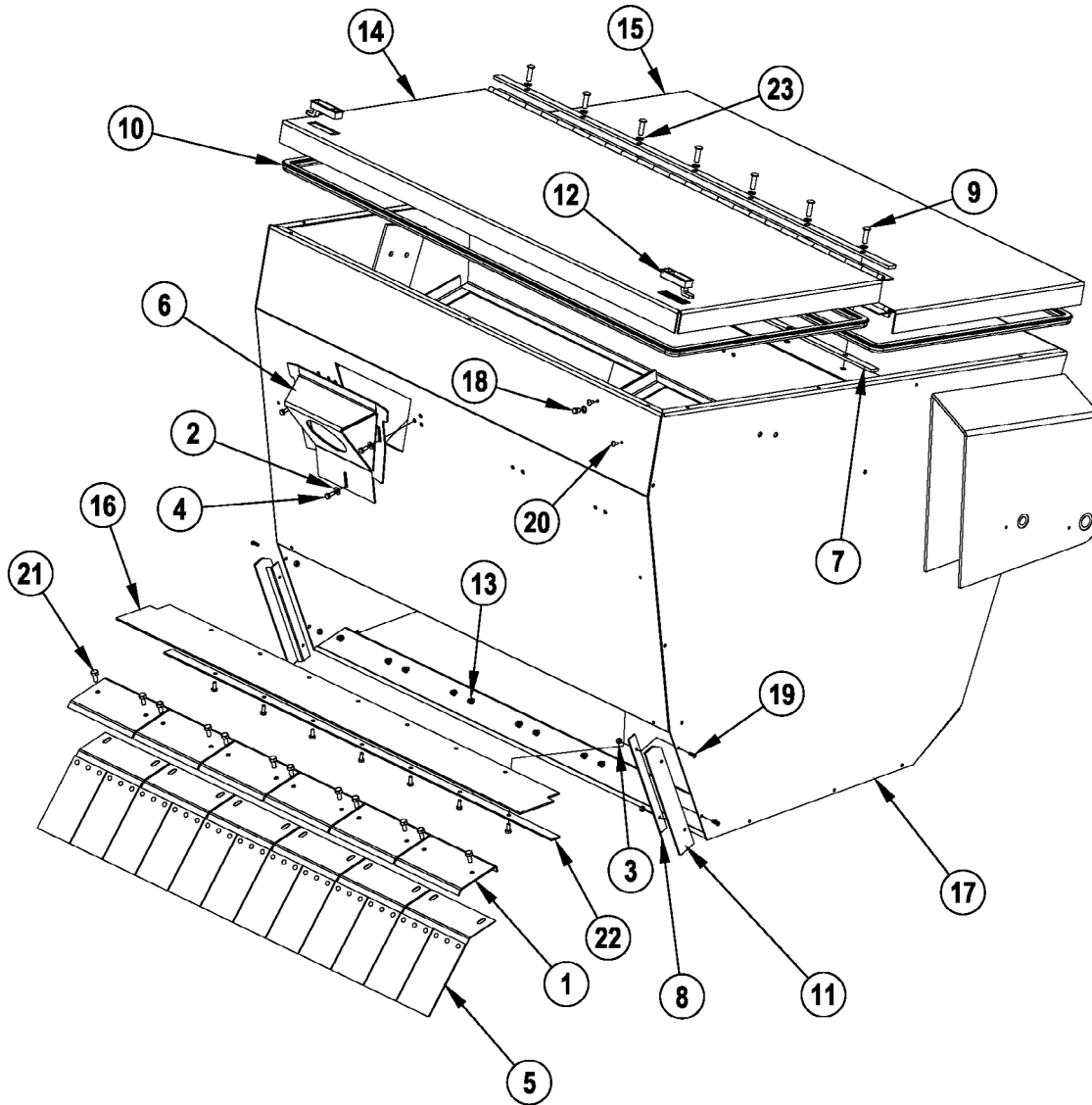

Item	Ref. No.	Qty	Description	Item	Ref. No.	Qty	Description
1	8-13-07084	6	Clamp Flap Hopper Bottom	13	2-00-00530	12	5/16" Lock Washer
2	56002098	3	Wsh, Fit Sae 1/4	14	56516771	1	Cover Weldment, Upper
3	56002836	6	Nut, Hex Nyl Loc Ss 10-24	15	56516761	1	Cover, Weldment
4	56002922	10	Scr, Hex Hd Loc 1/4-20x.62	16	8-25-08179	1	Flap Hopper Upper
5	56109460	6	Flap Hopper	17	56516760	1	Hopper Weldment
6	56516770	1	Weldt Blower Mounting Plate	18	2-00-03778	1	Plug, 1/8 Npt
7	56516773	2	Spacer	19	2-00-04794	4	Screw, #10-24 X .63 Bhs
8	56516775	2	Clamp, Hopper Side	20	2-00-03061	2	Screw, #10-24 X 1.00 Truss Head
9	2-00-04667	7	Scr, Button Soc 3/8-16 X 1.25	21	2-00-00208	12	Screw, 5/16-18 X .750 Hhc
10	3-73-00060	2	Seal Hopper Cover	22	56516767	1	Strap, Primary Deflector Flap
11	8-25-08180	2	Flap Hoppe Side	23	2-00-02310	7	Washer-Lock, 3/8", Helical Spring
12	8-41-00044	2	Latch				

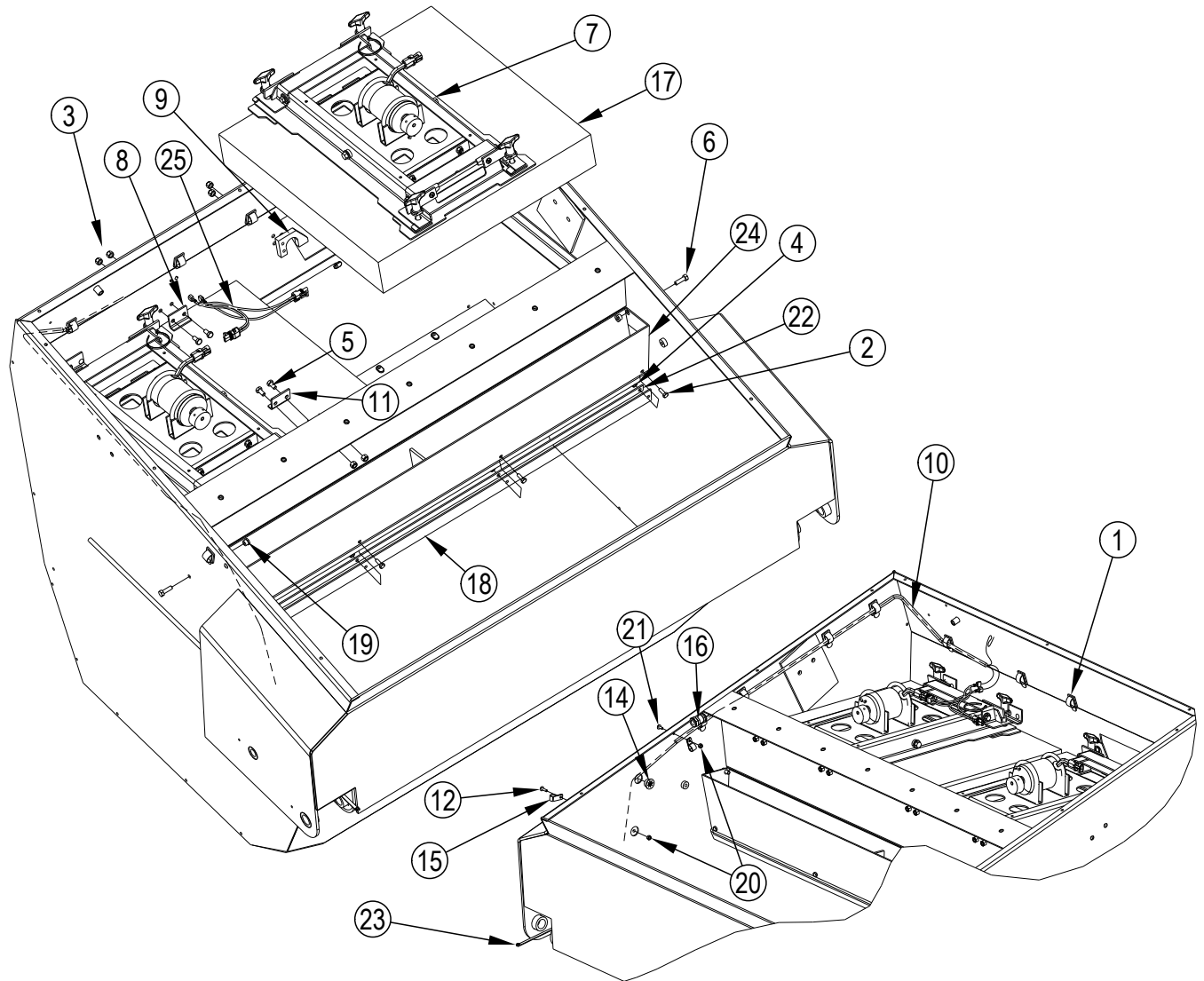

Item	Ref. No.	Qty	Description	Item	Ref. No.	Qty	Description
1	7-13-07096	8	Clamp-Adjustable	14	8-09-01082	1	Bushing, Star
2	56002155	4	Scr, Hex 1/4-20 X .75	15	2-00-04210	2	Clamp
3	56002701	14	Nut, Hex Nyl Loc 5/16-18	16	8-09-01083	1	Connector, Bulkhead
4	56002708	4	Nut, Hex Nyl Loc 1/4-20	17	8-24-04123-1	2	Filter
5	56002035	16	Scr, Hex 5/16-18 x .62	18	8-25-08228	1	Flap - Hopper Vac Chamber
6	56003073	2	Scr, Hex Hd Loc 5/16-18x1.00	19	7-23-03056	2	Nut
7	56109440	2	Filter Shaker Assembly	20	2-00-01246	2	Nut-#10-24 Elastic Stop Nut
8	56109450	7	Bracket Filter Clamp Rr	21	2-00-03061	1	Screw, #10-24 X 1.00 Truss Head
9	56381958	1	Bracket-Shaker	22	56516777	1	Strap - Hopper Vac Chamber
10	0875-108	1	Wire Assembly Hopper	23	2-00-04345	1	Ty-Rap (Thomas&Betts Ty-28m)
11	56109443	4	Bracket Filter Clamp Ft	24	56516776	1	Weldment, Air Guide
12	2-00-03063	1	Screw, #10-24 X .75, Round Head	25	56109462	1	Jumper Shaker Motor

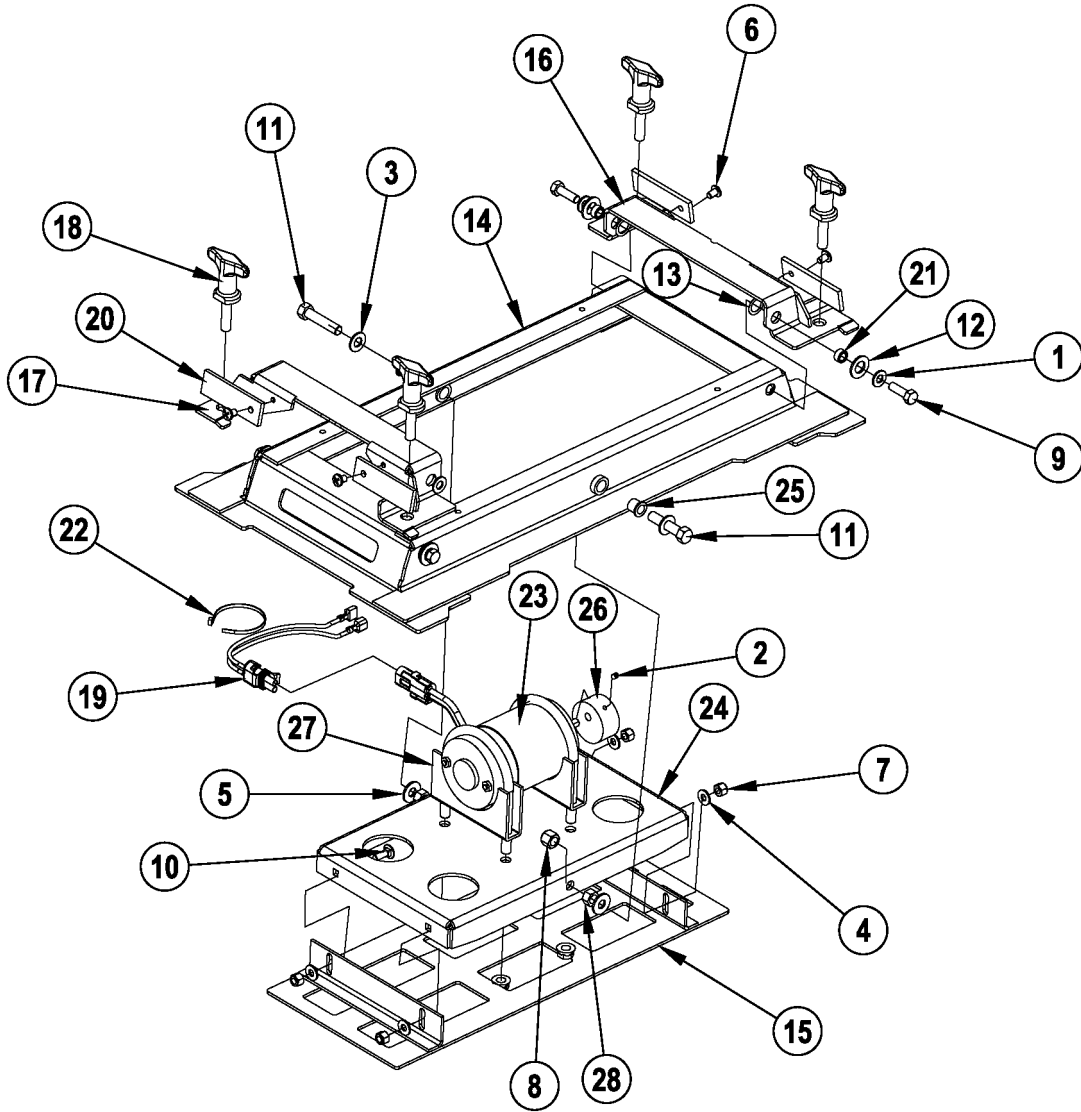

Item	Ref. No.	Qty	Description
1	56001939	4	Wsh, Flt Sae 5/16
2	56002015	2	Scr, Soc Set Loc 10-24 X .25
3	56002063	2	Wsh, Flt Sae 3/8
4	56002098	4	Wsh, Flt Sae 1/4
5	56002220	2	Wsh, Flt Std 5/16
6	56002462	4	Scr, Pan Phil 1/4-20 X .38
7	56002708	4	Nut, Hex Nyl Loc 1/4-20
8	56002769	2	Nut, Hex Nyl Loc 3/8-16
9	56003073	4	Scr,Hex Hd Loc 5/16-18x1.00
10	56003715	4	Scr, Carriage Ss 1/4-20 X .75
11	56003771	2	Scr,Hex Hd Loc 3/8-16x1.75 Grade 8
12	56009003	4	Wsh, Flt .516 X .938 X .075
13	56009265	4	Washer, Wave .531
14	56109441	1	Filter Shaker Wedgt
15	56109444	1	Shaker Weldment
16	56109446	1	Clamp Filter Shaker Weldt Rr
17	56109448	1	Clamp Filter Shaker Weldt
18	56109459	4	Knob 3/8-16 Male Thread
19	56109462	1	Jumper Shaker Motor
20	56109464	4	Bar Lock Knob
21	56320595	4	Bushing .32x.50x.28
22	56478246	1	Tie, Cable
23	56508664	1	Motor, 12vdc
24	56508705	1	Plate Shaker Motor Mtg
25	56508737	2	Bearing, Fl .500x.375x.500
26	56508772	1	Eccentric
27	56508887	2	Clamp Muffler 3" X 3/8-16
28	2-00-02360	2	Nut, Hex, 3/8-16

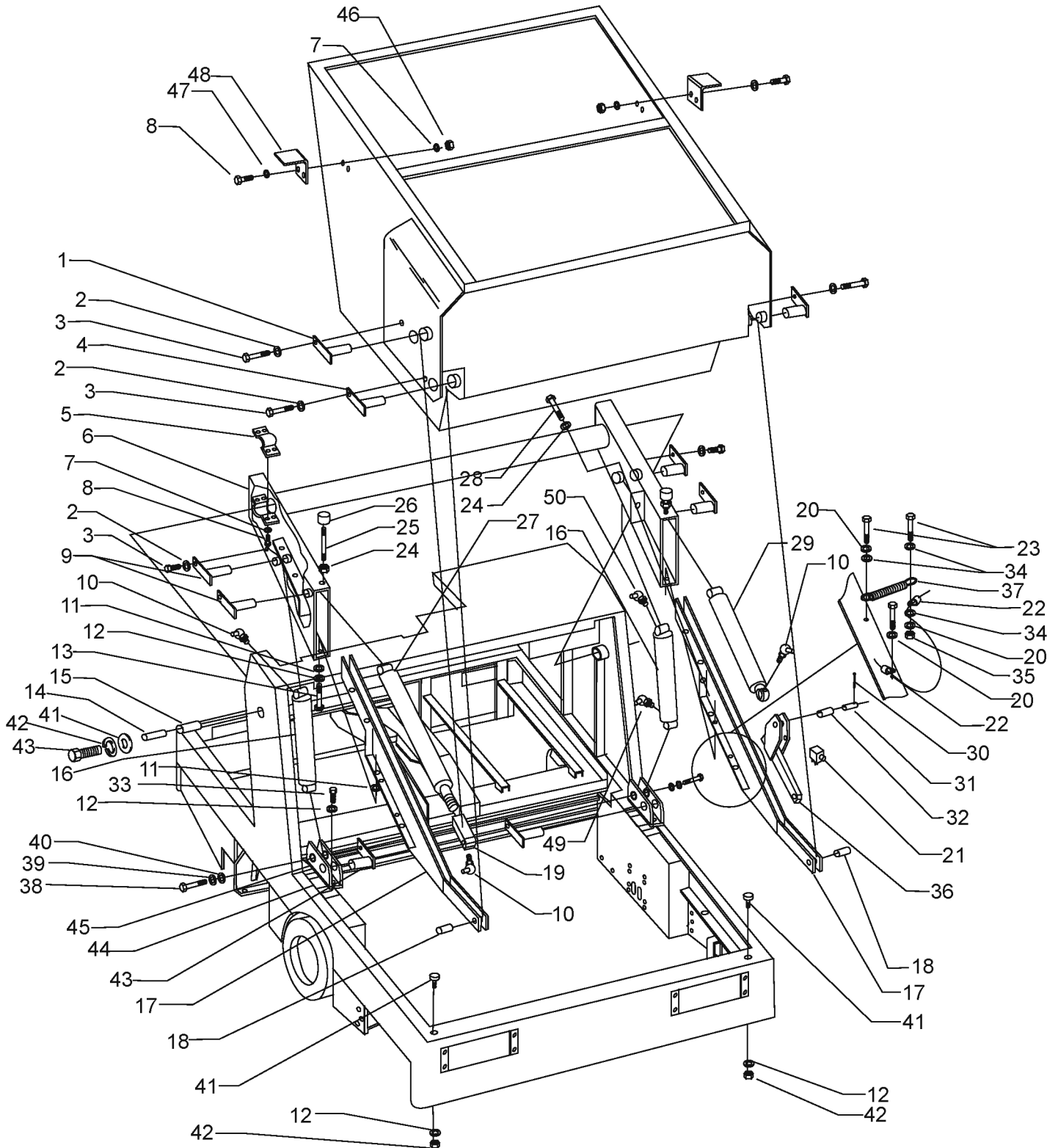

Item	Ref. No.	Qty	Description
1	56516823	1	Hopper Dump Pin
2	2-00-00518	7	Lock Washer, Helical Spring 1/4 Med
3	2-00-00221	7	Screw, 1/4 - 20 x .750 HHC
4	56516822	2	Hopper Pivot Pin
5	8-13-07103	2	Pivot Pin Half Clamp
6	56516819	1	Arm Pivot Bracket Assembly
7	2-00-02310	12	Lock Washer, Helical Spring 3/8 Med
8	2-00-00234	8	Screw, 3/8 - 16 x 1.000 HHC
9	56516820	4	Pin (Upper)
10	2-00-02558	4	Lubrication Fitting, 45° 1/8 NPT
11	2-00-04159	8	Flat Washer, 1.375 x .562 x .109
12	2-00-02312	8	Lock Washer, Helical Spring 1/2 Med
13	2-00-01254	6	Screw, 1/2 - 13 x 1.500 HHC
14	8-55-08107	2	Pin (Arm Pivot)
15	2-00-04893	2	Sleeve Bearing, 2.005 x 1.503 x 2.000
16	8-17-05029	2	Lift Cylinder
	0880-449	2	Seal Kit for Lift Cylinder
17	56516816	2	Lower Arm
18	2-00-04894	2	Sleeve Bearing, 1.254 x 1.003 x 2.500
19	8-14-01010	1	Clevis, Dump Cylinder
20	2-00-00519	5	Lock Washer, Helical Spring #10 Med
21	8-82-00050	1	Switch Lift Arm Lockout
22	2-00-04378	2	Clip, .281
23	2-00-00056	3	Screw, #10 - 24 x .750 RHM
24	2-00-02371	2	Nut, Hex Hvy. Jam 1/2 - 13 x .875 x .296
25	8-80-05014	2	Stud, 1/2-13 UNF-2A
26	7-78-05009	2	Stop Pad
27	8-17-05028	1	Dump Cylinder
	0880-505	1	Seal Kit for Dump Cylinder
28	2-00-04967	4	Screw, 1/2 - 13 x 2.500 HHM
29	8-17-05030	1	Rotation Cylinder
	0880-450	1	Seal Kit for Rotation Cylinder
30	2-00-02436	1	Cotter Pin, .187 x 1.750
31	8-55-08103	1	Hopper Rotate Pin
32	8-06-01083	1	Bushing,
33	2-00-00240	4	Screw, 1/4 - 13 x 1.250 HHC
34	2-00-00426	3	Flat Washer, .500 x .218 x .062
35	2-00-00605	1	Nut, Hex MS #10 - 24 x .375 x .125
36	56516817	1	Rotate Cylinder Bracket
37	7-76-00050-1	1	Spring
38	2-00-00213	2	Screw, 5/16 - 18 x .625 HHC
39	2-00-00530	2	Lock Washer, Helical Spring 5/16 Med
40	2-00-00409	2	Flat Washer, .687 x .343 x .062
41	8-50-05054	2	Rubber Pad
42	2-00-00596	2	Nut, Hex 1/2 - 13
43	56516820	2	Pin (Lower)
44	8-71-00017	1	Shim
45	56516824	2	Adjustable Lift Arm Bracket
46	2-95-04689	2	Washer
47	2-00-02310	2	Washer, 3/8 Lock
48	56516821	2	Bracket, Hopper Stop

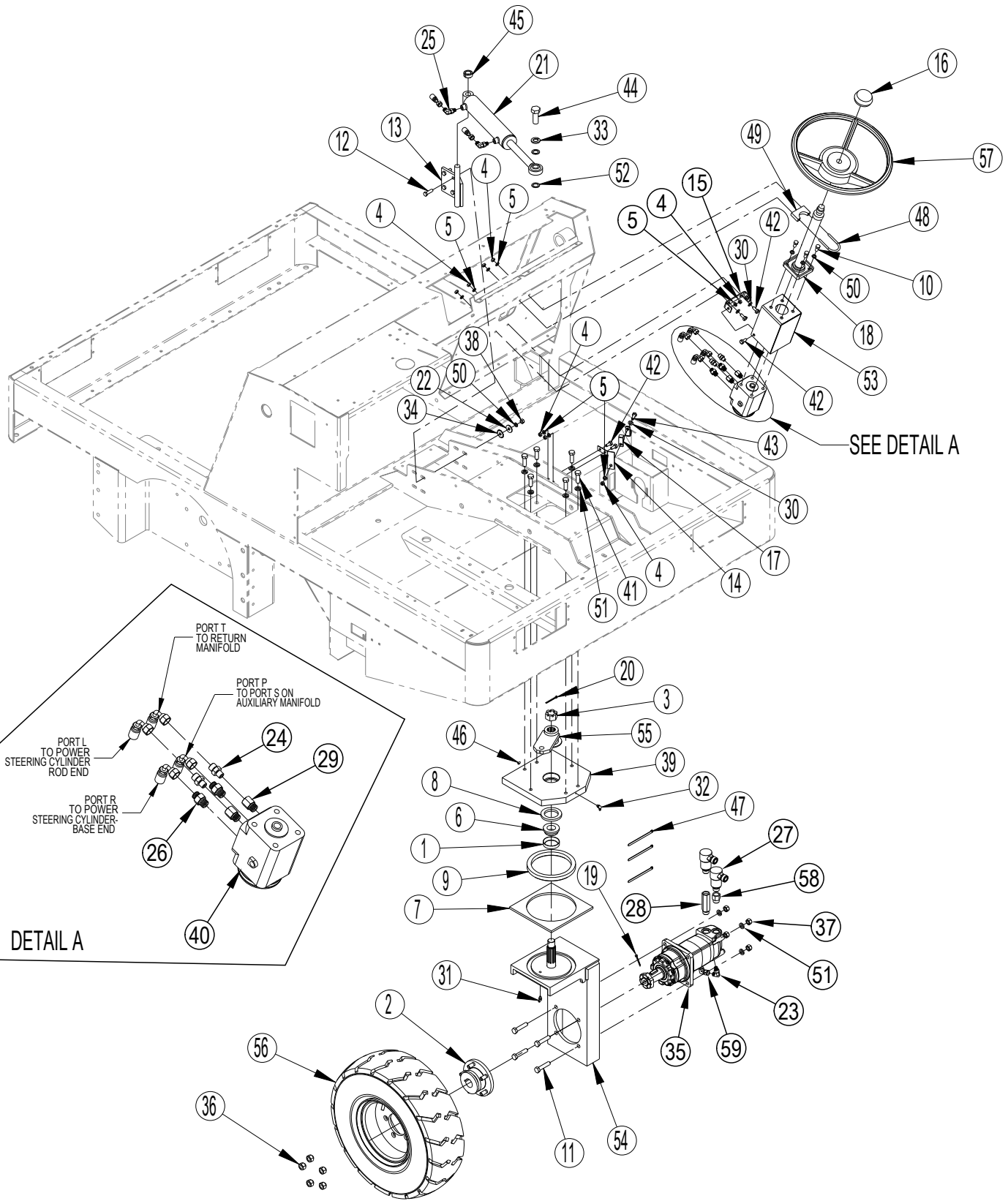

Item	Ref. No.	Qty	Description	Item	Ref. No.	Qty	Description
1	2-00-04621	1	Bearing Cup	31	2-00-02558	1	Grease Fitting
2	0860-536	1	Hub/Stud Assy - Rear Wheel	32	2-00-02559	1	Grease Fitting- 1/4-28 X 90°
[]	8-33-09081	1	Hub Only (Service)	33	2-00-00522	1	Lock Washer
[]	7-80-05056-1	5	Studs (Service)	34	2-00-03829	4	Lock Washer, 3/8 Int./Ext. Tooth
3	2-00-05026	1	1" X 14 Slotted Nut	35	56109709	1	Wheel Motor NOTE 1
4	2-00-00585	9	5/16-18, Hex Nut	[]	56109718	1	Seal kit (for 56109709)
5	2-00-00530	9	5/16" Lock Washer	[]	56463039	1	Nut (for 56109709)
6	2-00-02079	1	Bearing Cone W/ Seal	[]	8-70-00026	1	Key (for 56109709)
7	8-68-05097	1	Bearing Seal	36	56009116	5	Nut-Wheel
8	8-68-05098	1	Bearing Seal	37	2-00-00596	4	Nut, Hex Head, 1/2-13 X .44 Lg
9	2-00-04455	1	Bearing, Thrust	38	2-00-02360	4	Nut, Hex, 3/8-16
10	2-00-00232	4	Bolt-Hex Head, Finished, 3/8-16	39	8-58-05269	1	Plate, Rear Wheel Pivot
11	2-00-00242	4	Bolt, 1/2-13 X 2.00 Long	40	8-60-05023	1	Pump, Power Steering
12	2-00-00209	4	Bolt, Hex Head, 3/8-16 X 1 1/4 Ss	41	2-00-01254	6	Screw, Hex, 1/2-13 X 1.50
13	8-08-00727	1	Bracket, Cylinder Pivot	42	2-00-00208	6	Screw, 5/16-18 X .750 Hhc
14	8-08-00733	1	Bracket, Cylinder Pivot	43	2-00-02708	1	Screw, Hex Head, 5/16-18 X 1.00"
15	8-08-00728	1	Bracket, P/S Unit Mount	44	2-00-05341	1	Screw, Hhc .75-10 X 2.00 Gr5 Zn
16	8-11-00022	1	Cap Steering Wheel	45	8-15-01003	1	Set Screw Collar
17	2-00-04564	2	Clamp, Cable	46	2-00-00256	1	Set Screw, 1/4-20 X .38 Hs-Kcp
18	8-70-05287	1	Column, Steering, Assembly	47	2-00-04345	3	Ty-Rap (Thomas&Betts Ty-28m)
19	2-00-00776	1	Cotter Pin (1/8 Dia. X 1-1/2 Lg.)	48	8-13-07085	1	U-Bolt, 1/4-20
20	2-00-04803	1	Cotter Pin (1/8 Dia. X 2 Lg.)	49	8-08-00578	1	W/D, U Bolt Ass'y
21	8-17-05029	1	Cylinder	50	2-00-02310	8	Washer-Lock, 3/8", Helical Spring
22	2-00-03266	4	Fan Washer	51	2-00-02312	10	Washer, 1/2" Lock
23	2-00-04892	1	Fitting-90 Elbow NOTE 1	52	2-00-00432	2	Washer, Flat, 3/4"ld
24	2-00-04895	2	Fitting-Straight Connector	53	56516787	1	Weldment - Stg Cntrl Housing
25	2-00-04892	2	Fitting-90° Elbow (O-Ring)	54	8-92-00043	1	Weldment-Drive Wheel Yoke
26	2-00-04918	2	Fitting, -6 SAE X -4 Ors, Str.	55	56516788	1	Weldment, Steering Arm
27	2-00-05358	2	Fitting, -10 SAE X -10 Ors, Swivel	56	8-89-08059	1	Wheel, 21.50 Dia. Pneumatic
28	56109705	1	Adapter-Hydraulic Motor NOTE 1	[]	8-85-06022		Tire Only (Service)
29	2-00-04917	2	Fitting, Reducer, -6 Orb - -4 Orb	[]	8-70-00087		Tube (Service)
30	2-00-00409	3	Flat Washer, .687 X .344 X .062	57	7-89-08041	1	Wheel, Steering
				58	56900602	1	Reducer O-Ring NOTE 1
				59	2-00-05545	1	Ftg-4 Ors Swivel Elbow 90 Deg

[] = Not Shown

NOTE 1: The old wheel motor 0885-054-1 is no longer used in production and no longer available for replacement. If replacing 0885-054-1 please order Wheel Motor Kit 56109738.

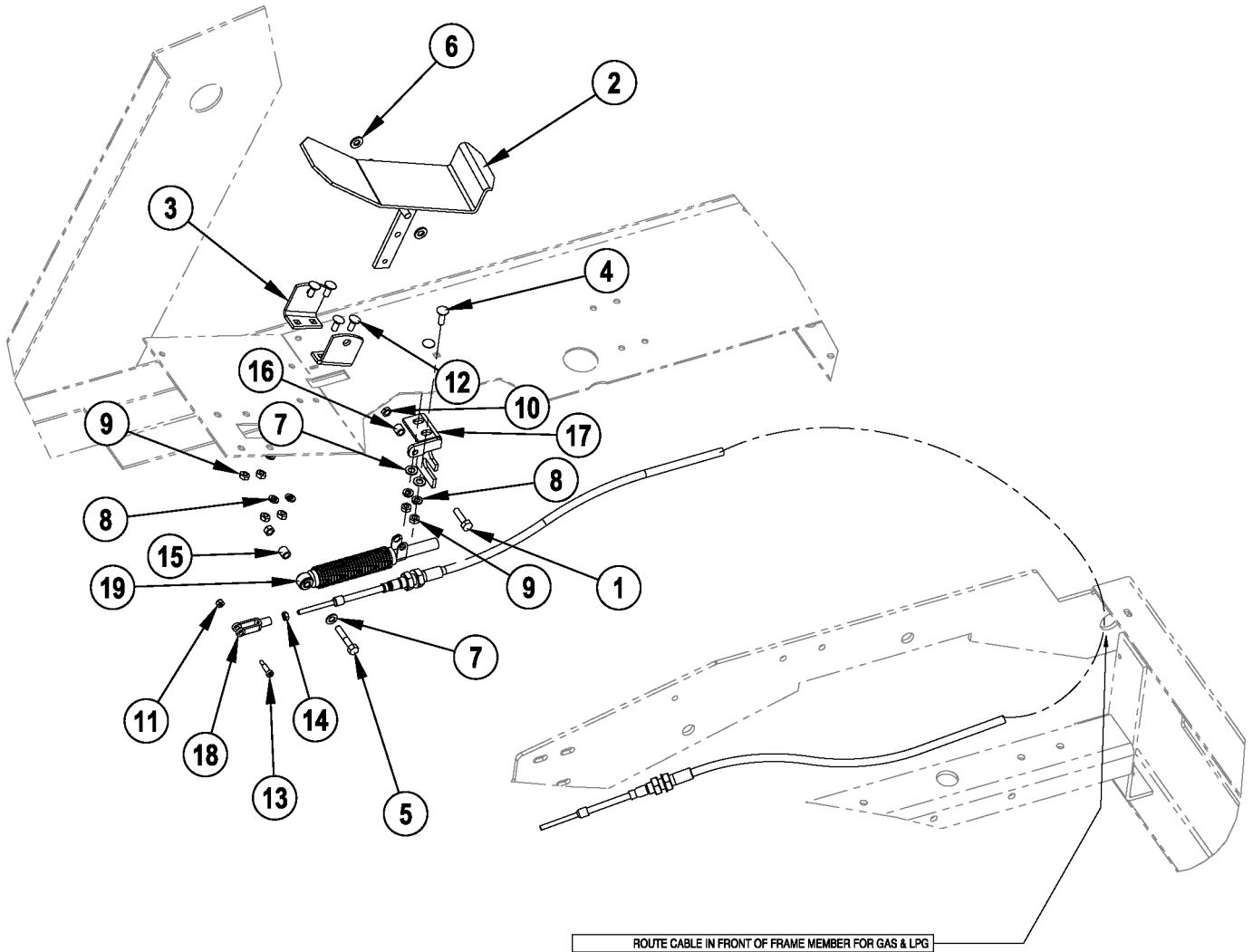

Item	Ref. No.	Qty	Description
1	2-00-00207	1	Screw, Hex Head 5/16-18 X 1.25"
2	56516833	1	Weldment Fwd/Rev Pedal
3	56516834	2	Bracket Fwd/Rev Pedal Pivot
4	2-00-00196	2	Bolt-Car, .31-18 X 1 Gr 5 Zn
5	2-00-00211	1	Bolt-Hex Head, Finished, 5/16-18
6	2-00-00402	2	Washer, 25/64" Id X 3/4" Od
7	2-00-00409	3	Flat Washer, .687 X .344 X .062
8	2-00-00530	6	5/16" Lock Washer
9	2-00-00585	6	5/16-18, Hex Nut
10	2-00-00644	2	Nut, Hex, Insert Fiber, 5/16-18
11	2-00-01246	1	Nut-#10-24 Elastic Stop Nut
12	2-00-03569	4	Bolt, Carriage
13	2-00-04563	1	Shoulder Screw 1/4" X 5/8"
14	2-95-01999	1	Nut- 1/4-28 Hex Jam
15	7-75-01130	1	Spacer
16	7-75-01209	1	Spacer
17	8-08-00898	1	Bracket-Fwd/Rev/Damper
18	8-14-01006	1	Clevis
19	8-17-05035	1	Lever damper Kyb

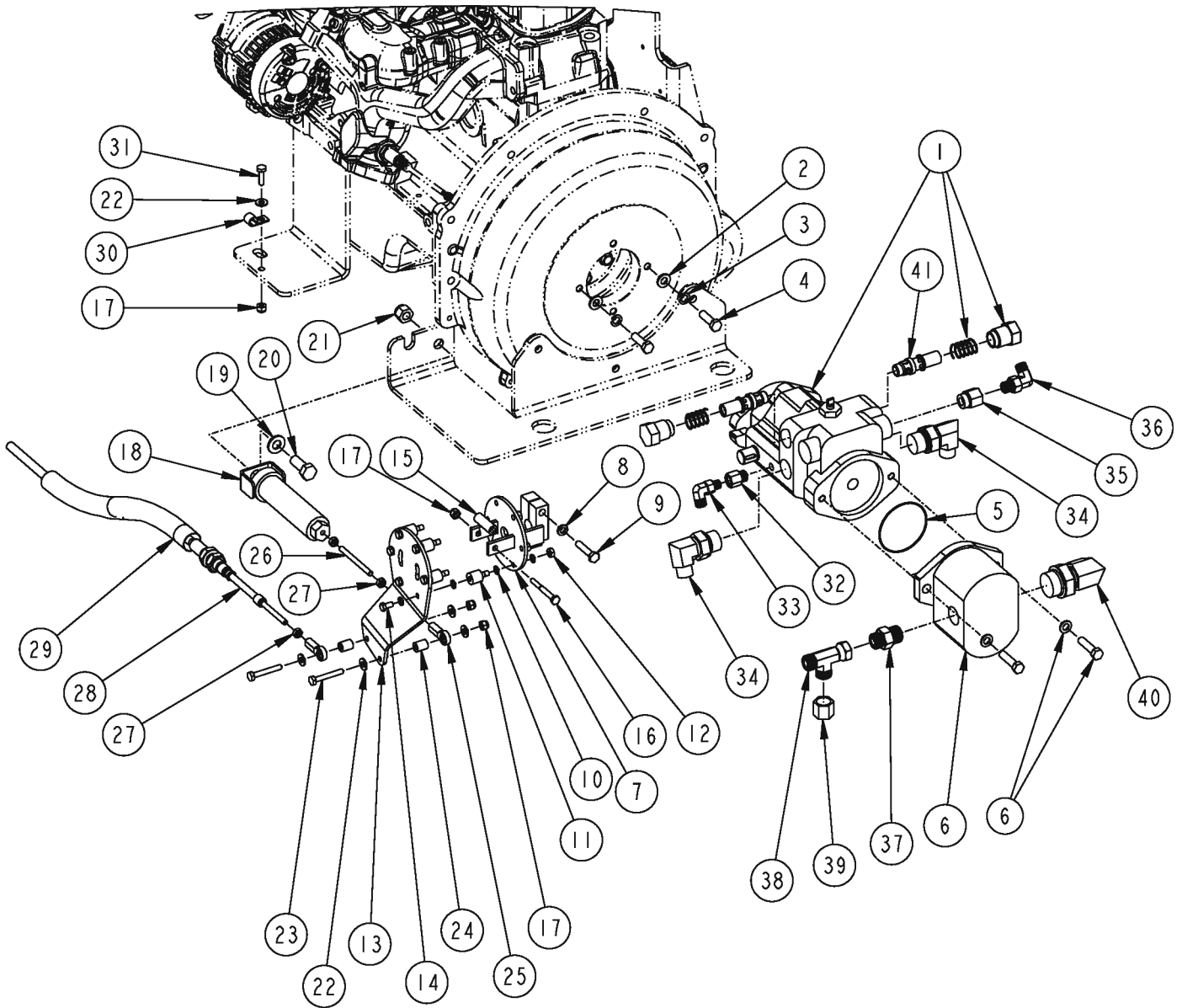

Item	Ref. No.	Qty	Description
1	8-60-05006-2	1	Drive Pump
2	2-00-00402	2	Flat Washer, .750 x .390 x .093
3	2-00-02310	2	Lock Washer, Helical Spring 3/8 Med
4	2-00-00209	2	Bolt, 3/8-16 x 1.25 Hex Head
5	0880-404	1	Kit, Pump Assembly
6	8-60-05022	1	Pump, Auxiliary (1.20 C.I.R.)
7	7-03-04105	1	Transmission Arm (Weldment)
8	2-00-00530	1	Lock Washer, 5/16
9	2-00-00225	1	Screw, 5/16-18 x 1.50 HHC
10	2-00-00501	24	Lock Washer, 1/4 Int.
11	7-75-01089	6	Spacer, Sandwich Mount
12	2-00-00594	6	Nut, Hex 1/4-20 x .437 x .218
13	7-58-05361	1	Plate, Hydrostat Arm
14	2-00-00219	6	Bolt, 1/4-20 x 1/2 Fin. Hex Head
15	7-75-01110	1	Spacer, Transmission Arm
16	2-00-00246	1	Screw, 1/4-20 x 2.25 HHC
17	2-00-00641	4	Nut, 1/4-20 Fiber Insert
18	8-16-00025	1	Centering Control
19	2-00-00405	1	Flat Washer, 1.062 x .531 x .093
20	2-00-00240	1	Screw, 1/2-13 x 1.25 HHC
21	2-00-04936	1	Lock Nut, 1/2-13 Elastic
22	2-00-03702	5	Washer, .625 x .281 x .063
23	2-00-01769	2	Screw, 1/4-20 x 1.75
24	7-75-01274	2	Spacer, 1/4" ID x 1/2" OD - 5/8"
25	7-25-02111	2	Rod End, 1/4 Female
26	7-66-00147	1	Rod, Centering Control Adjustment
27	2-95-01999	3	Nut, 1/4-28 Hex Jam
28	8-16-00068	1	Cable, Forward/Reverse
29	8-34-09038	1	Reflective Sleeve (1" dia. x 14")
30	2-00-04602	1	Clamp
31	2-00-01490	1	Screw, 1/4-20 x .875 Hex Head
32	2-00-04917	1	Fitting, -6 ORB to -4 ORB Reducer
33	2-00-04892	1	Fitting, 90° Elbow (O-Ring)
34	2-00-04922	2	Fitting, -8 ORS to -10 SAE 90° Elbow
35	2-00-04932	1	Fitting, Reducer
36	2-00-04926	1	Fitting, 9/16-18 x 9/16-18 Elbow
37	2-00-04974	1	Fitting, #8 ORS to #10 SAE Connector
38	2-00-04928	1	Fitting, -08 ORFS Run Tee
39	2-00-04957	1	Fitting, 8 ORS Cap
40	2-00-04920	1	Fitting, 90° Elbow
41	8-88-00065	2	Kit, Relief Valve

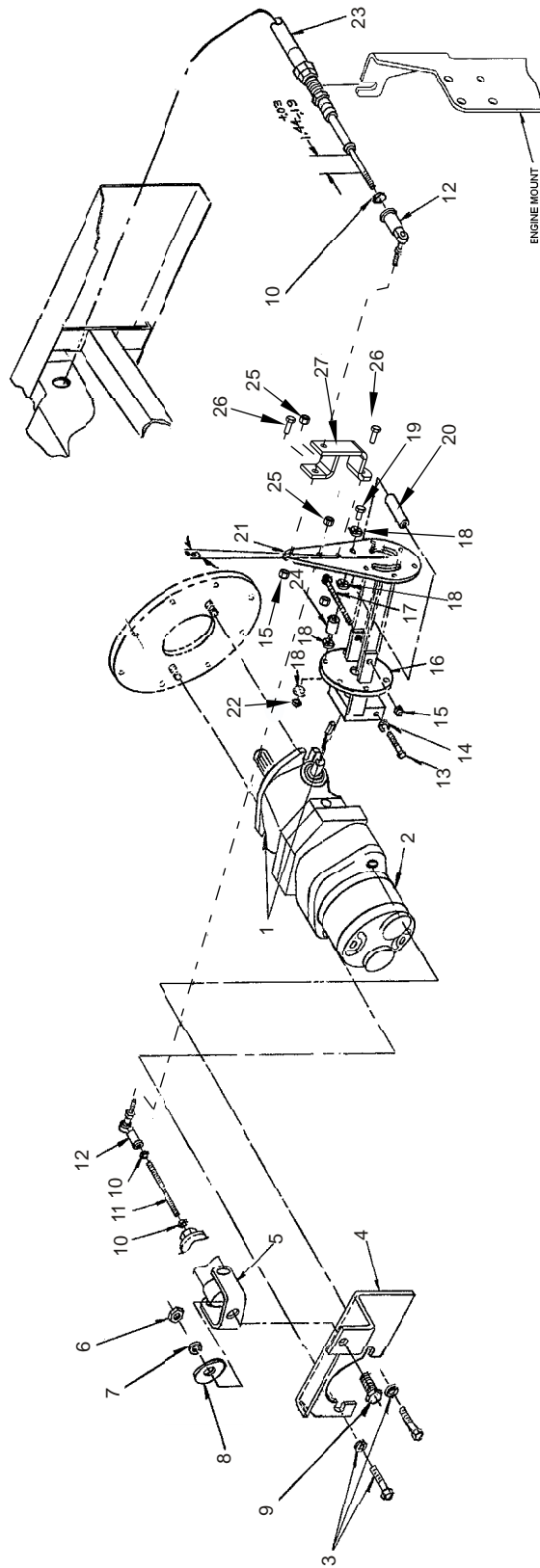

09-5

FORWARD/REVERSE ASSEMBLY (DIESEL ONLY)

11-3

Granterra**29**

Item	Ref. No.	Qty	Description
1	8-60-05006-2	1	Pump, Piston (1.24 C.I.R.)
2	8-60-05022	1	Pump, Auxiliary (1.20 C.I.R.)
3	0880-404	1	Kit, Pump Assembly
4	56516832	1	Bracket, Hydroback
5	8-16-00025	1	Centering Control
6	2-00-00596	1	Nut, 1/2-13 Hex
7	2-00-02312	1	Lock Washer, 1/2 Helical Spring
8	2-00-00405	1	Flat Washer, 1/2
9	2-00-00240	1	Scr-1/2-13 x 1.25
10	2-95-01999	4	Nut, 1/4-28 Hex Jam
11	7-66-00147	1	Rod, 1/4-28 x 3.0
12	7-25-02050	2	Rod End, 1/4-28
13	2-00-00225	1	Screw, 5/16-18 x 1.50 HHC
14	2-00-00530	1	Lock Washer, 5/16 Helical Spring
15	2-00-00641	2	Nut, 1/4-20 Fiber Insert Hex
16	7-03-04105	1	Transmission Arm (Weldment)
17	2-00-01246	1	Nut, #10-24 Fiber Insert Hex
18	2-00-00501	24	Lock Washer, 1/4 Int.
19	2-00-00219	6	Screw, 1/4-20 x 1/2 HHC
20	7-75-01110	1	Spacer, Transmission Arm
21	7-58-05220	1	Plate, Transmission Arm
22	2-00-00594	6	Nut, 1/4-20 Hex
23	8-16-00045	1	Cable, Forward/Reverse
24	7-75-01089	6	Isolator
25	56003284	2	Nut-Hex Nyl Loc 1/4-28
26	2-00-00221	2	Scw-HHC 1/4-20 x .75
27	8-08-00682	1	Pump Plate Bracket

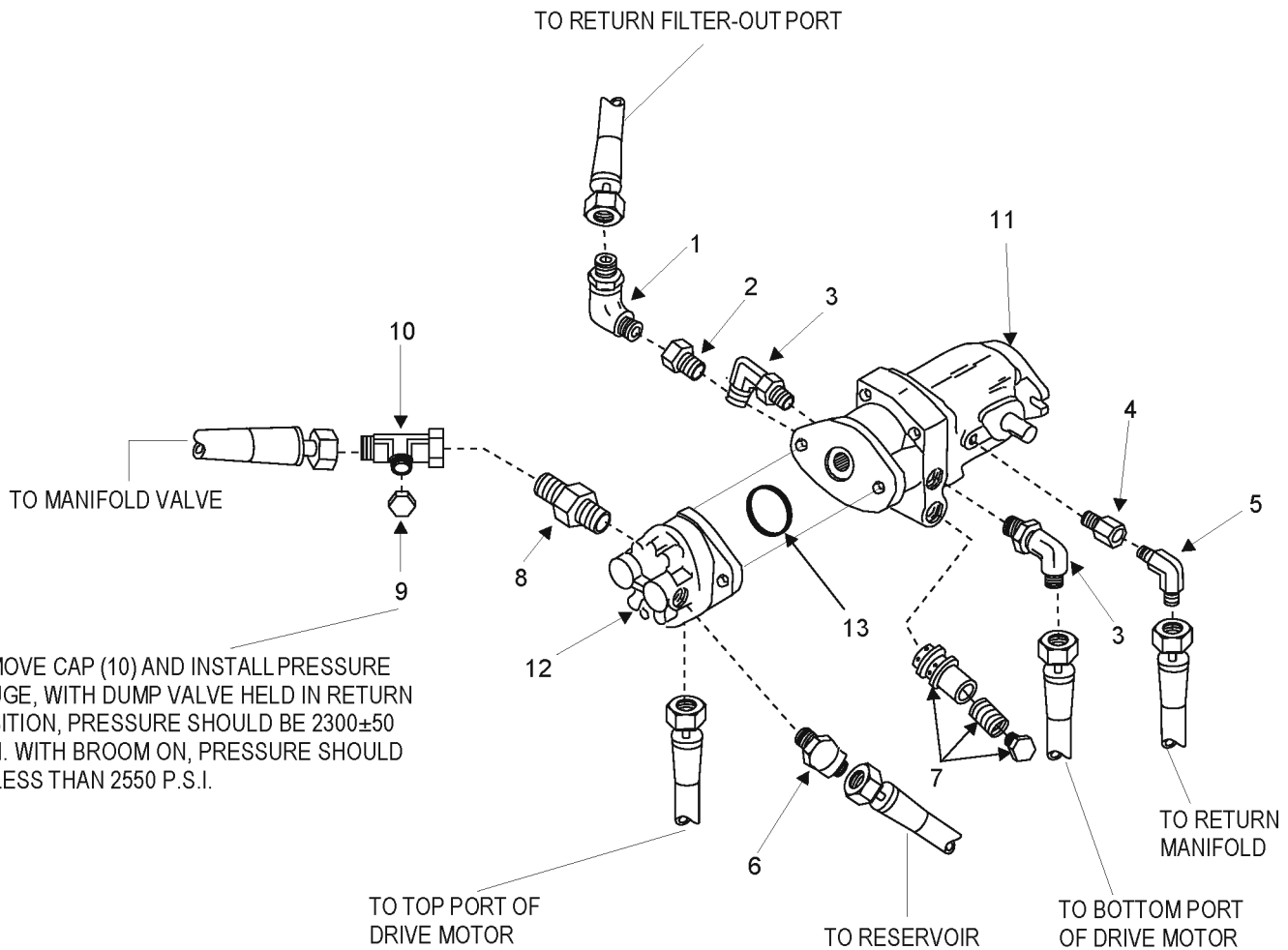

Item	Ref. No.	Qty	Description
1	2-00-04926	1	ORFS 90° Elbow 9/16-18
2	2-00-04932	1	ORFS Boss Reducer, 3/4-16 x 9/16-18
3	2-00-04922	2	ORFS 90° Elbow, 1 1/16-12 to 13/16-16
4	2-00-04917	1	ORFS Boss Reducer, 9/16-18 to 7/16-20
5	2-00-04892	1	Fitting, 90° Elbow
6	2-00-04920	1	Fitting, 90° Elbow
7	8-88-00065	2	Relief Valve Kit
8	2-00-04974	1	Fitting Straight
9	2-00-04957	1	Fitting Cap
10	2-00-04928	1	Fitting Tee
11	8-60-05006-2	1	Main Pump
12	8-60-05022	1	Auxiliary Pump
13	0880-404	1	Kit, Pump Assembly

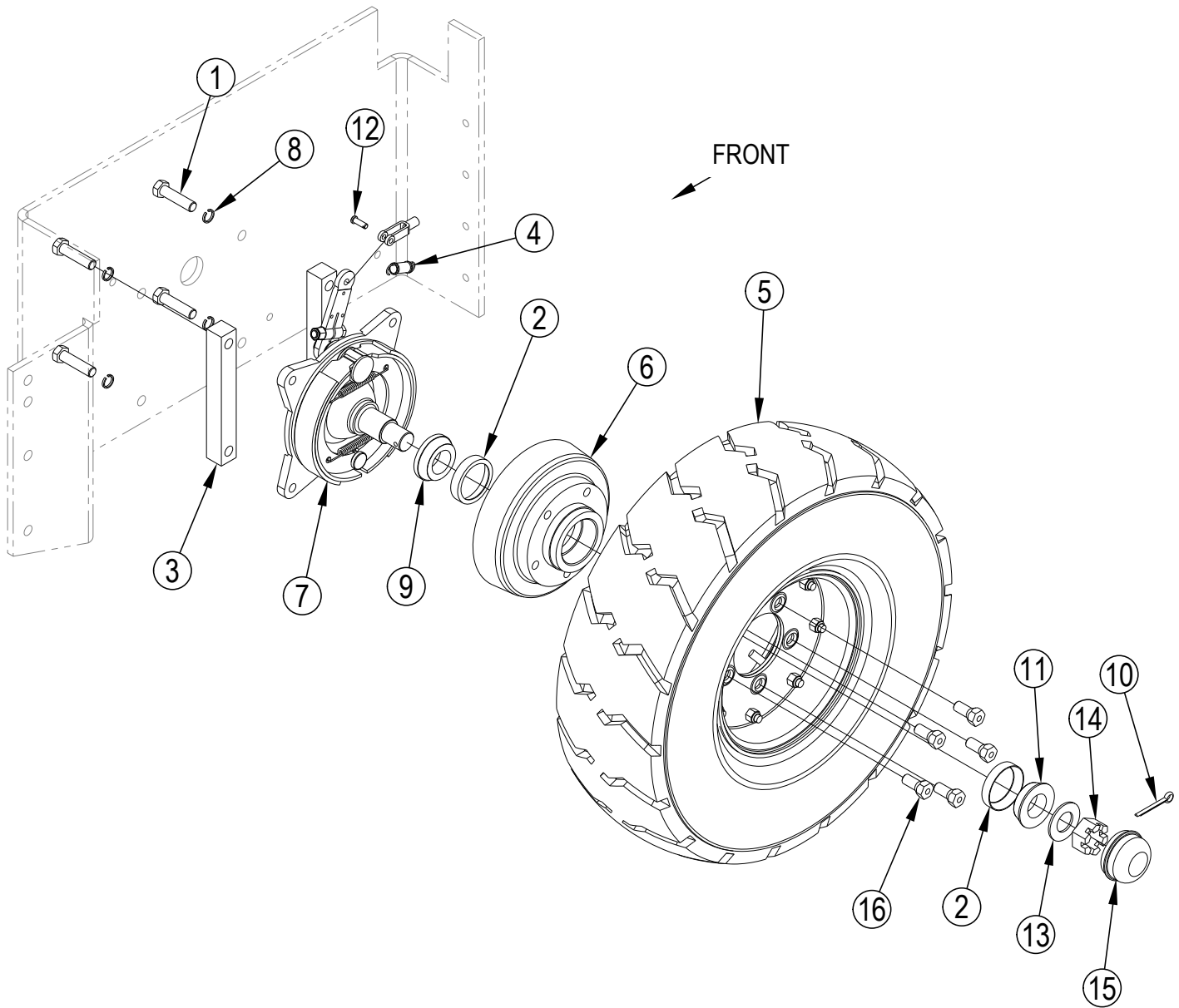

Item	Ref. No.	Qty	Description
1	56003162	8	Scr, Hex 1/2-20 X 2.00
2	2-00-04621	4	Bearing Cup
3	8-75-01216	4	Spacer
4	8-76-00042	2	Spr-Lever-Lift-Brush-Gutter
5	8-89-08054	2	Whl Assy Pneumatic Front 6X9
*	8-85-06022	2	Tire, Pneumatic 6 x 9
*	8-70-00087	2	Tube
*	8-70-00086	2	Flap-Pneumatic Tire 9.0x6.7
*	8-65-05016	2	Rim Assembly, 6 x 9 x 4
6	56107724	2	Hub And Drum-Machined
7	0860-703	2	Axle / Shaft Assy
8	2-00-00504	8	Lock Washer, 1/2 Dia
9	2-00-02079	2	Bearing Cone W/ Seal
10	2-00-02436	2	Pin, Cotter
11	2-00-04622	2	Cone Timken Bearing
12	2-00-04909	2	Pin, 1/4 X 3/4 Lg
13	2-00-05024	2	Washer-Flat
14	2-00-05026	2	1" X 14 Slotted Nut
15	8-11-00030	2	Grease Cap
16	8-80-05035	10	Stud - Wheel

* Service Parts

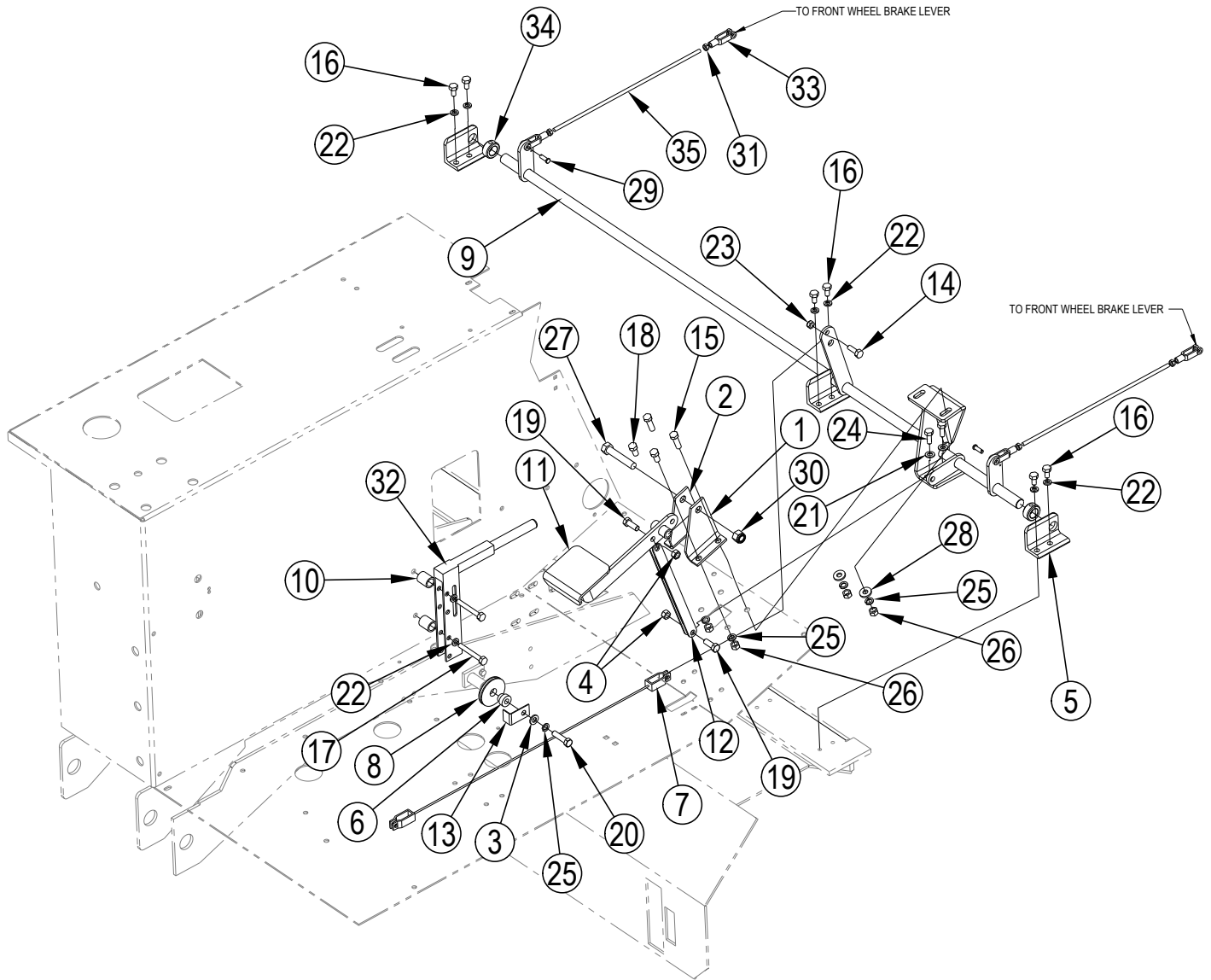

Item	Ref. No.	Qty	Description
1	56516799	1	Bracket Side Plate Rh
2	56516800	1	Bracket Side Plate Lh
3	2-00-00402	1	Washer, 25/64" Id X 3/4" Od
4	2-95-04182	2	Nut, Hex, Stop, 3/8-16
5	8-08-00571	2	Bracket Shaft
6	8-09-01065	1	Bushing Pulley
7	8-10-00032	1	Brake Cable Assy
8	8-60-00140	1	Pulley
9	8-70-05288	1	Weldt Pivot Shaft Brake Pedal
10	8-75-01184	2	Spacer Lever Mounting
11	56516796	1	Brake Pedal Weldment
12	56516797	1	Weldment-Brake Link
13	56516798	1	Bracket
14	2-00-00206	1	Bolt 5/16-18, 3/4 Lg
15	2-00-00209	2	Bolt, Hex Head, 3/8-16 X 1 1/4 Ss
16	2-00-00213	6	Screw, Hex Head, 5/16-18 X 5/8"
17	2-00-00228	2	Hex Screw, 5/16-18 X 2.5
18	2-00-00232	2	Bolt-Hex Head, Finished, 3/8-16
19	2-00-00233	2	Bolt-Hex Head, Finished, 3/8-16 X 1.00
20	2-00-00234	1	Screw, 3/8-16 X 1-1/2 Hhc
21	2-00-00409	2	Flat Washer, .687 X .344 X .062
22	2-00-00530	8	5/16" Lock Washer
23	2-00-00644	1	Nut, Hex, Insert Fiber, 5/16-18
24	2-00-01255	2	5/16-18 X 7/8 Lg Hex Head Screw
25	2-00-02310	5	Washer-Lock, 3/8", Helical Spring
26	2-00-02360	4	Nut, Hex, 3/8-16
27	2-00-02682	1	1/2-13 Screw X 2.75 Lg
28	2-00-04801	2	Flat Washer, 1.00 X .39 X .06
29	2-00-04909	2	Pin, 1/4 X 3/4 Lg
30	2-00-04936	1	Locknut-Elastic, 1/2-13
31	2-95-01999	4	Nut- 1/4-28 Hex Jam
32	7-41-05083	1	Lever-Parking Brake
33	8-14-01006	4	Clevis
34	8-15-01003	2	Set Screw Collar
35	8-66-00154	2	Threaded Rod - 1/4-28 X 14"

Item	Ref. No.	Qty	Description
1	2-00-02708	4	Screw, 5/16-18 x 1.0 HHM
2	8-56-05077	1	Fitting, Special 90° Elbow
3	2-00-01676	2	Flat Washer, 1.062 x .265 x .062
4	2-00-04885	1	Fitting, ORFS 90° Elbow, (Modified)
5	2-00-04997	1	Fitting, ORFS 1/4 NPT - #4 ORS
6	8-24-04133	1	Return Filter
7	8-75-01181	2	Spacer
8	2-00-03575	4	Carriage Bolt, 1/4-20 x .750
9	2-00-04976	1	Fitting
10	2-00-00409	10	Flat Washer, .687 x .343 x .062
11	2-00-00530	10	Lock Washer, Helical Spring 5/16 Med
12	2-00-00585	10	Nut, 5/16-18 x .50 x .265 Hex
13	8-24-04118	1	Replacement Filter Element
14	2-00-05133	4	Elbow
15	0882-041	1	Hydraulic Motor
	7-70-00020	1	Seal Kit for Hydraulic Motor 0882-041
	2-00-02227	1	Key, .125 x .750 SQ
16	2-00-02220	2	Clamp, Hose
17	56516801	1	Bracket, Lower Impeller
18	56516803	1	Shroud, Impeller
19	8-23-00012	1	Impeller
20	2-00-00252	4	Screw, 5/16-18 x 4.0 HHC
22	2-00-00484	1	Flat Washer, .625 x .375 x .046
23	2-00-00632	1	Nut, 3/8-24 Fiber Insert Hex
24	8-29-00111	1	Gasket, Shroud
25	56516802	1	Duct, Blower Throat
26	2-00-00518	9	Lock Washer, 1/4 Helical Spring
27	2-00-00594	8	Nut, 1/4-20 x .437 x .218 Hex
28	8-29-00183	1	Gasket
30	2-00-03702	11	Flat Washer, .625 x .281 x .062
31	8-33-02271	1	Hose, Blower Exhaust
32	2-00-03454	2	Band Clamp 5 1/8-6
33	56516805	1	Duct, Blower Exhaust Box
34	8-34-09009	1	Insulation, Side
35	8-34-09007	2	Insulation, Front
36	56516804	1	Bracket, Upper Impeller
37	8-34-09006	1	Insulation, Blower Box (Top)
38	8-34-09005	1	Insulation, Blower Box (Bottom)
39	2-00-00196	2	Carriage Bolt, 5/16-18 x 1.0
40	2-00-01803	2	Flat Washer, 5/16

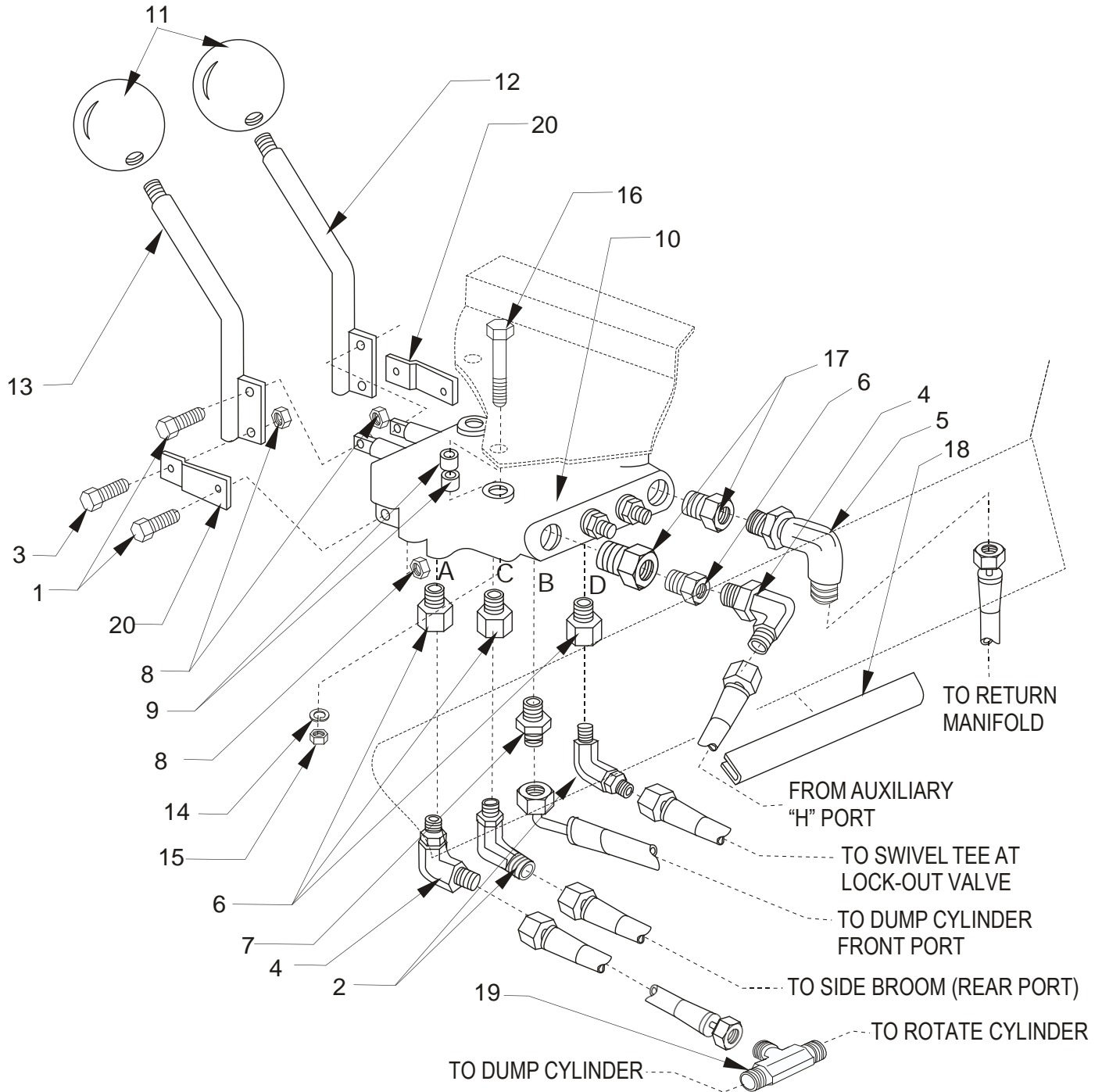

Item	Ref. No.	Qty	Description
1	2-00-04795	4	Screw, #10-24 x .750 BLTS
2	2-00-04976	2	45° Elbow, #4 SAE to #4 ORS
3	2-00-05162	1	Swivel Tee, #4 ORS
4	2-00-04892	2	ORFS 90° Elbow, #4 SAE to #4 ORS
5	2-00-04926	1	90° Elbow, #6 SAE to #4 ORS
6	2-00-04917	5	ORFS Boss Reducer, #6 SAE to #4 SAE
7	2-00-04918	2	ORFS Connector, #6 SAE to #4 ORS
8	2-00-01246	6	Nut, Hex Fiber Insert #10-24
9	8-15-01008	4	Spacer
10	8-88-00058	1	Hopper Control Valve
11	8-39-00002	2	Valve Lever Knob
12	8-41-05066	1	Control Valve Lever (L.H.)
13	8-41-05068	1	Control Valve Lever (R.H.)
14	2-00-00518	2	Lock Washer, Helical Spring 1/4 Med
15	2-00-00594	2	Nut, Hex 1/4 - 20 x .437 x .218
16	2-00-01980	2	Screw, 1/4-20 x 2.500 HHC
17	2-00-04932	2	Reducer, #8 SAE - #6 SAE
18	7-21-04031	1	Edging
19	2-00-04930	1	Fitting, Tee
20	8-41-05067	2	Linkage

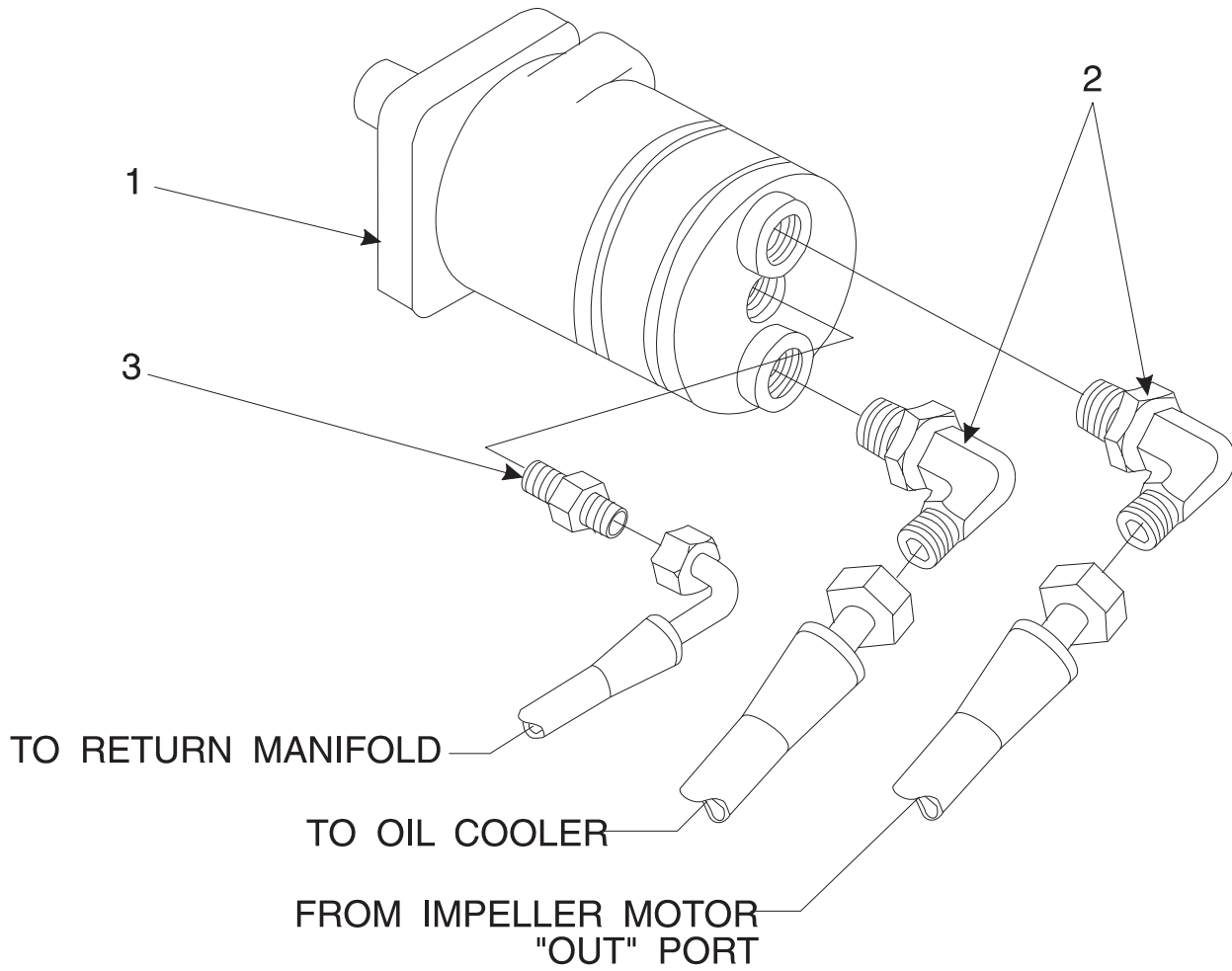

09-5	MAIN BROOM MOTOR & FITTINGS		
10-1	Granterra		41

Item	Ref. No.	Qty	Description
1	0882-040	1	Hydraulic Motor
NS	56479577	1	Motor Seal Kit
2	2-00-04885	2	ORFS 90° Elbow, 3/4-16 to 13/16-16
3	2-00-04895	1	ORFS Connector, 7/16-20 to 9/16-18

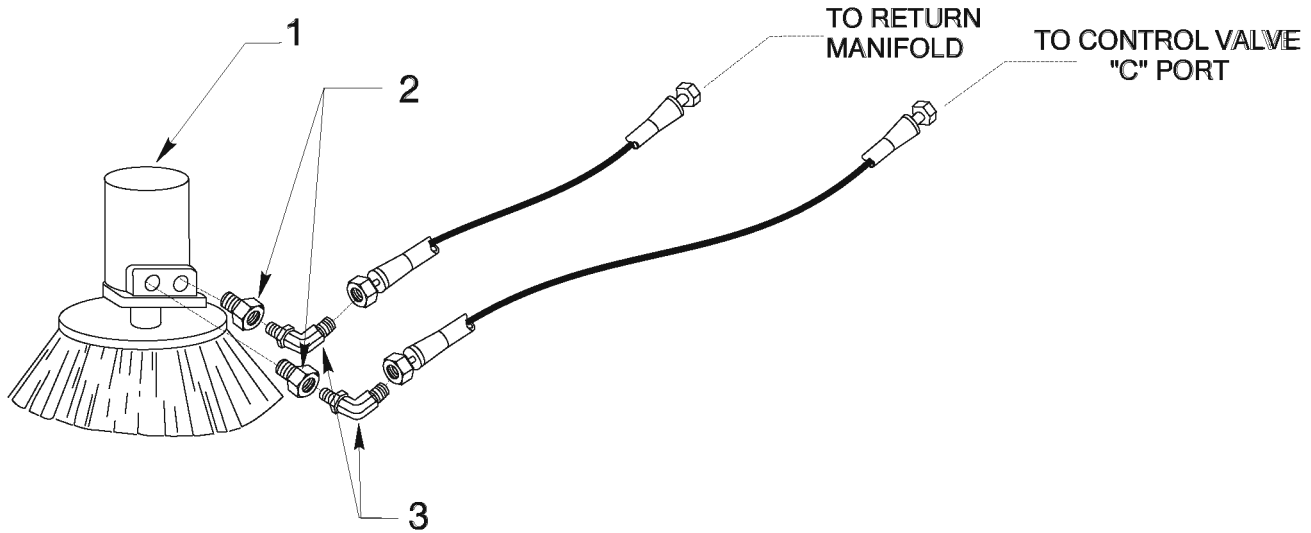

Item	Ref. No.	Qty	Description
1	0882-047	1	Hydraulic Motor
NS	56479577	1	Motor Seal Kit
2	2-00-04915	2	ORFS Boss Reducer, 7/8-14 to 9/16-18
3	2-00-04926	4	ORFS 90° Elbow, 9/16-18
4	0891-008	1	Side Broom Shut-Off Valve
5	2-00-04940	2	ORFS Swivel Nut Branch Tee, #4 ORS
6	7-12-02015	1	Cartridge for Shut-Off Valve

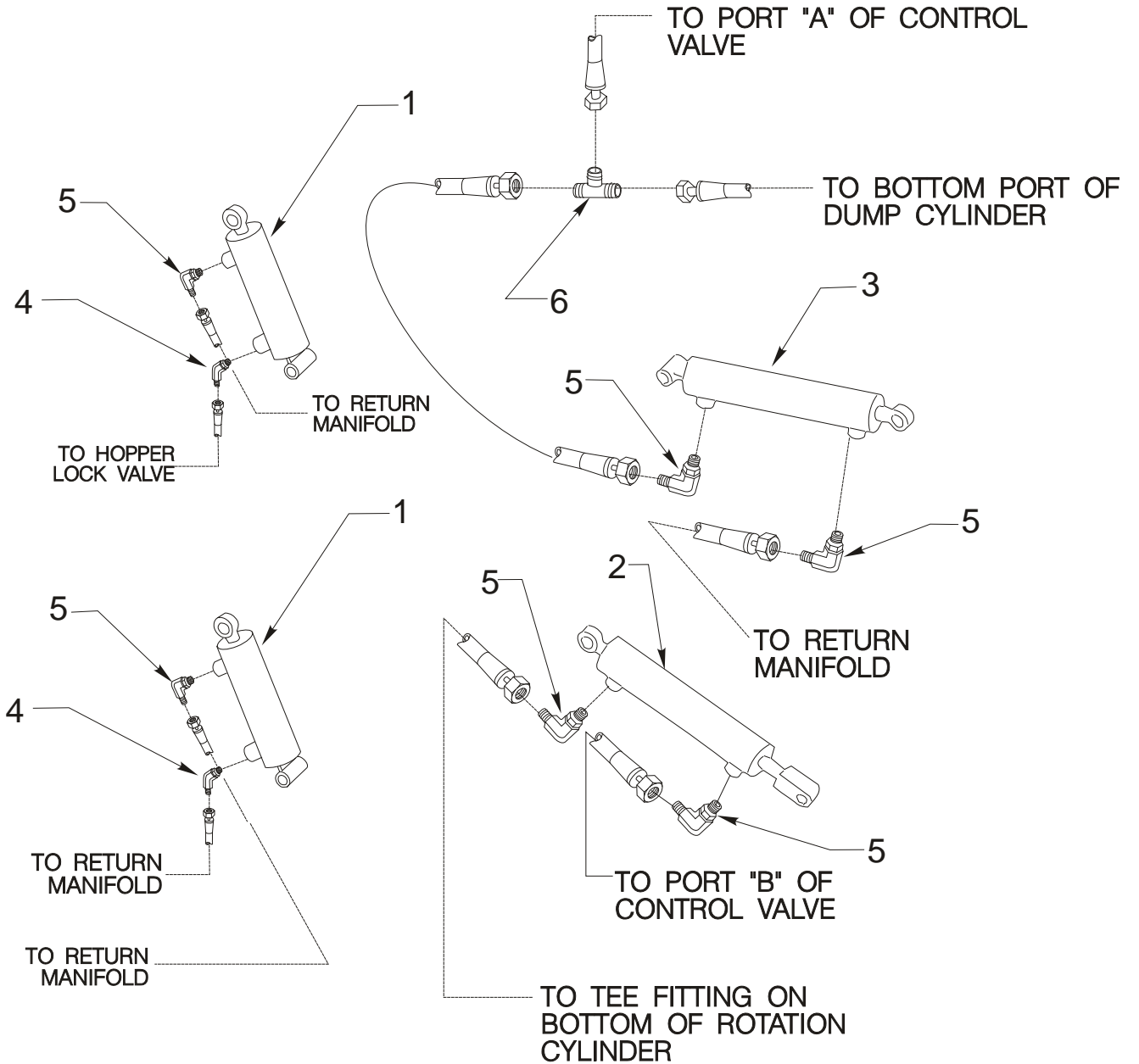

Item	Ref. No.	Qty	Description
1	8-17-05029	2	Lift Cylinder
2	8-17-05028	1	Dump Cylinder
3	8-17-05030	1	Rotation Cylinder
4	2-00-04976	2	ORFS Connector, 7/16-20 to 9/16-18
5	2-00-04892	6	ORFS 90° Elbow, 7/16-20 to 9/16-18
6	2-00-04930	2	ORFS Union Tee, 9/16-18
NS	0880-449	1	Lift Cylinder Seal Kit
NS	0880-505	1	Dump Cylinder Seal Kit
NS	0880-450	1	Rotation Cylinder Seal Kit

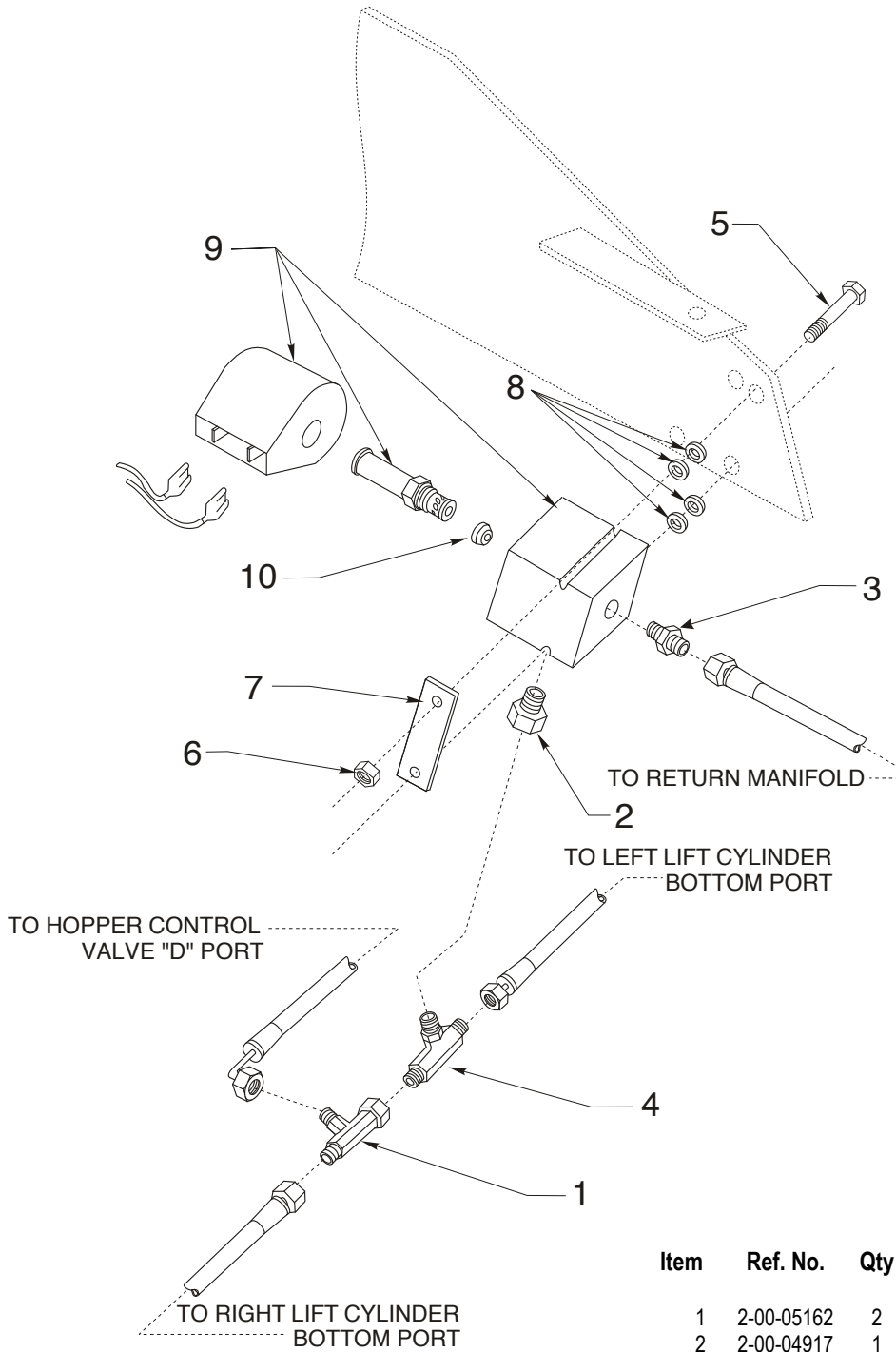

Item	Ref. No.	Qty	Description
1	2-00-05162	2	Tee, Swivel #4 ORS
2	2-00-04917	1	ORFS Boss Reducer, 9/16-18 to 7/16-20
3	2-00-04918	1	ORFS Connector, 7/16-18 to 9/16-18
4	2-00-04919	1	ORFS Branch Tee, 7/16-20 x (2) 9/16-18
5	2-00-02589	4	Screw, 1/4 - 20 x 2.000 HHC
6	2-00-00641	2	Nut, Hex Fiber Insert 1/4 - 20
7	8-08-00590	1	Bracket
8	2-00-03702	4	Flat Washer, .625 x .281 x .0625
9	8-88-00044	1	Hopper Lock Valve
10	8-88-00056	1	Orifice Disc

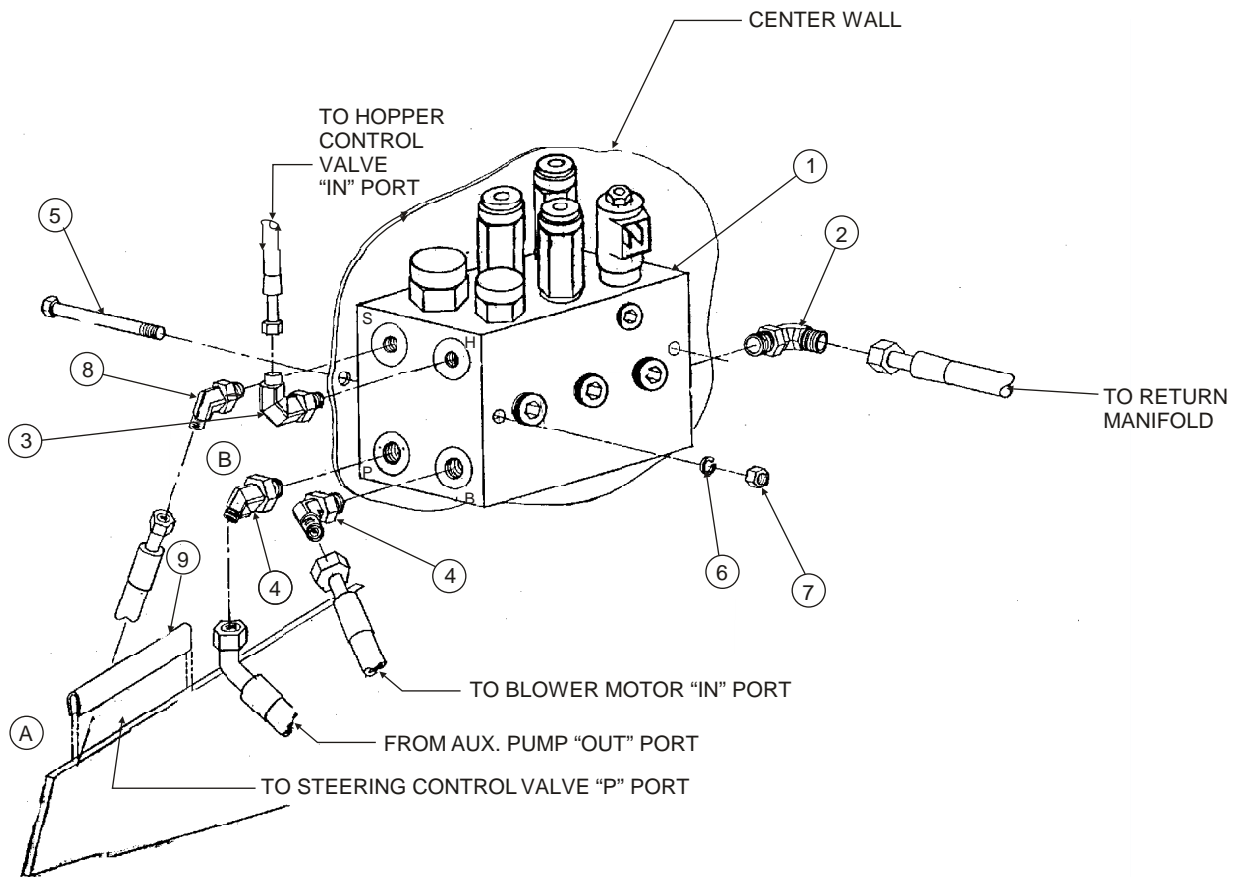

Item	Ref. No.	Qty	Description
1	8-88-00055	1	Auxiliary Manifold
	7-14-07004	1	Coil
2	2-00-04885	1	ORFS 90° Elbow, 3/4-16 / 13/16-16
3	2-00-04892	1	ORFS 90° Elbow, 7/16-20 / 9/16-18
4	2-00-04975	1	Fitting
5	2-00-04596	1	ORFS Nut, 13/16-16
6	2-00-00518	2	Lock Washer, Helical Spring 1/4 Med
7	2-00-00594	2	Nut, Hex 1/4 - 20
8	2-00-04976	1	Elbow 45° #4 SAE - ORS

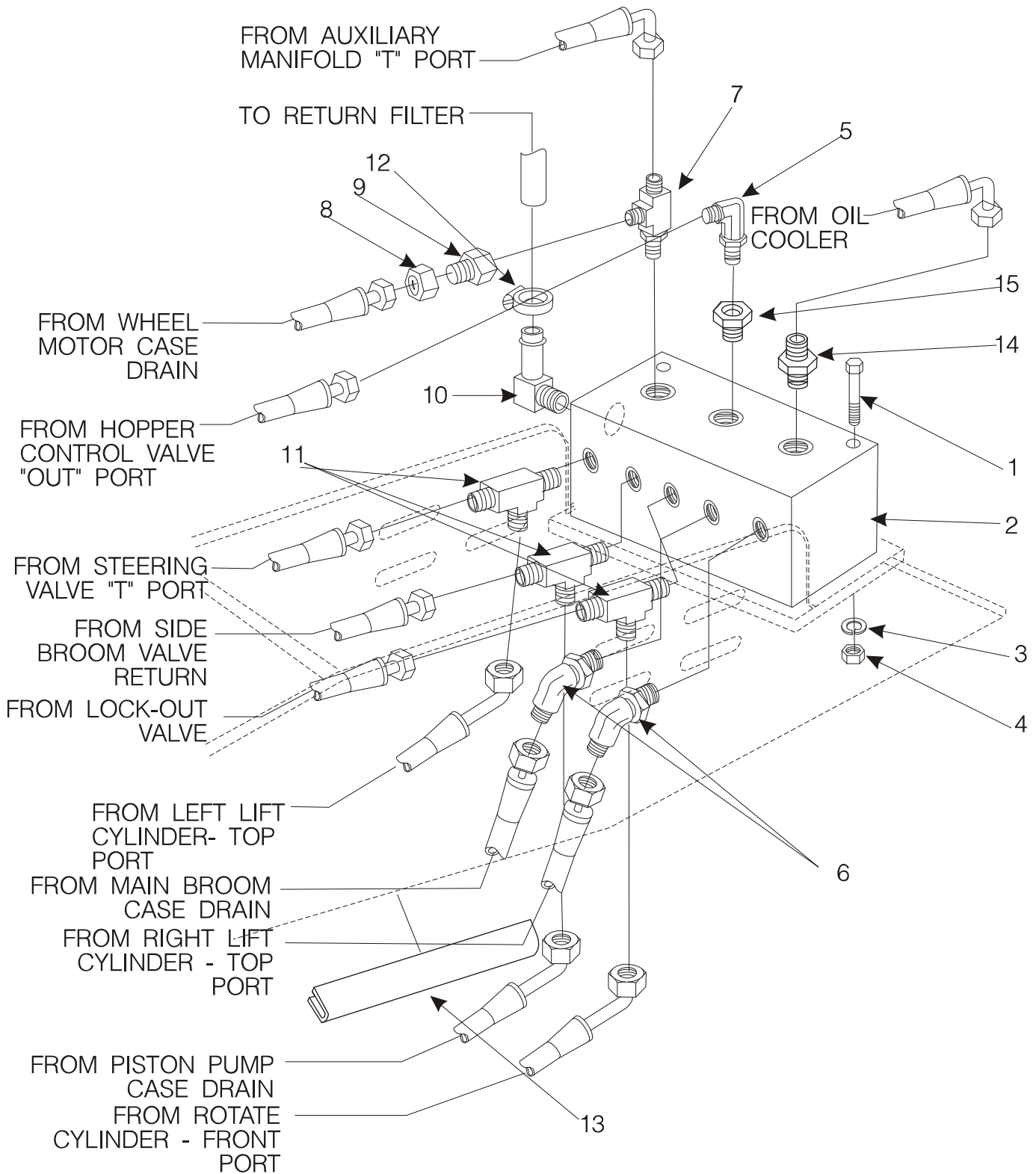

Item	Ref. No.	Qty	Description
1	2-00-04596	2	Screw, 1/4 - 20 x 3.50
2	7-48-00019	1	Return Manifold
3	2-00-00518	2	Lock Washer, Helical Spring 1/4 Med
4	2-00-00594	2	Nut, Hex 1/4 - 20 x .437 x .218
5	2-00-04926	3	ORFS 90° Elbow, 7/16-20 to 9/16-18
6	2-00-04976	3	45° Elbow, O-ring
7	2-00-04924	1	Swivel Tee
8	2-00-04939	1	Nut for Reducer Fitting
9	2-00-04929	2	Fitting, Reducer
10	2-00-05133	1	90° Elbow
11	2-00-04927	2	Run Tee, O-ring
12	2-00-02220	1	Clamp
13	7-21-04031	2	Edging
14	2-00-04970	2	Fitting, Straight #8 SAE - #8 ORS
15	2-00-04932	1	Fitting, Reducer #8 - #6 SAE

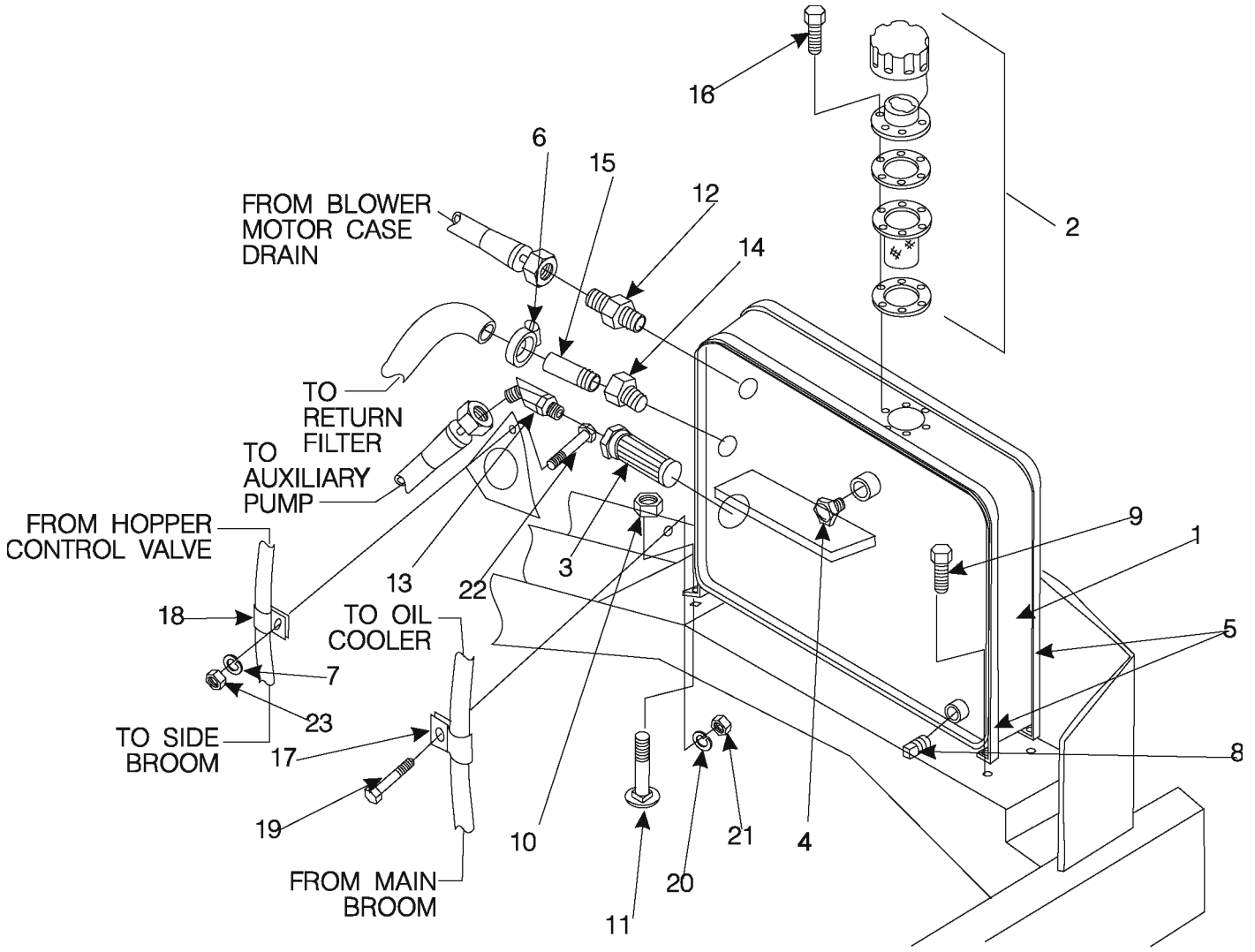

Item	Ref. No.	Qty	Description
1	8-83-04036	1	Hydraulic Reservoir
2	8-11-00026	1	Filler Cap Assembly
3	8-24-04115	1	Strainer
4	8-48-05033	1	Sight Glass
5	8-79-00114	2	Strap
6	2-00-02220	3	Hose Clamp, .812 - 1.500
7	2-00-00518	5	Lock Washer, 1/4
8	2-00-02474	1	Pipe Plug, 1/2 NPT
9	2-00-00205	4	Screw, 1/4 - 20 x 1.000 HHC
10	2-00-00641	2	Nut, 1/4-20 Fiber Lock
11	2-00-02196	4	Carriage Bolt, 1/4 - 20 x 1.000
12	2-00-04895	1	Fitting Strt, #4 SAE - #4 ORS
13	2-00-05037	1	Adapter, 3/4 ORS x 3/4 NPT 45° Elbow
14	2-00-04572	1	Reducer, #12 Ste - 3/4 NPT
15	2-00-03585	1	Pipe Nipple, 3/4 NPT
16	2-00-03940	6	Screw, #10-24 x .500 T/C HH
17	2-00-04564	1	Hose Clamp, 13/16
18	2-00-04873	1	Clamp
19	2-00-02708	1	Screw, 5/16-18 x 1.000 HHC
20	2-00-00530	1	Lock Washer, 5/16
21	2-00-00585	2	Nut, Hex 5/16-18
22	2-00-02196	2	Carriage Bolt, 1/4-20 x 1.000

[] = Not Shown

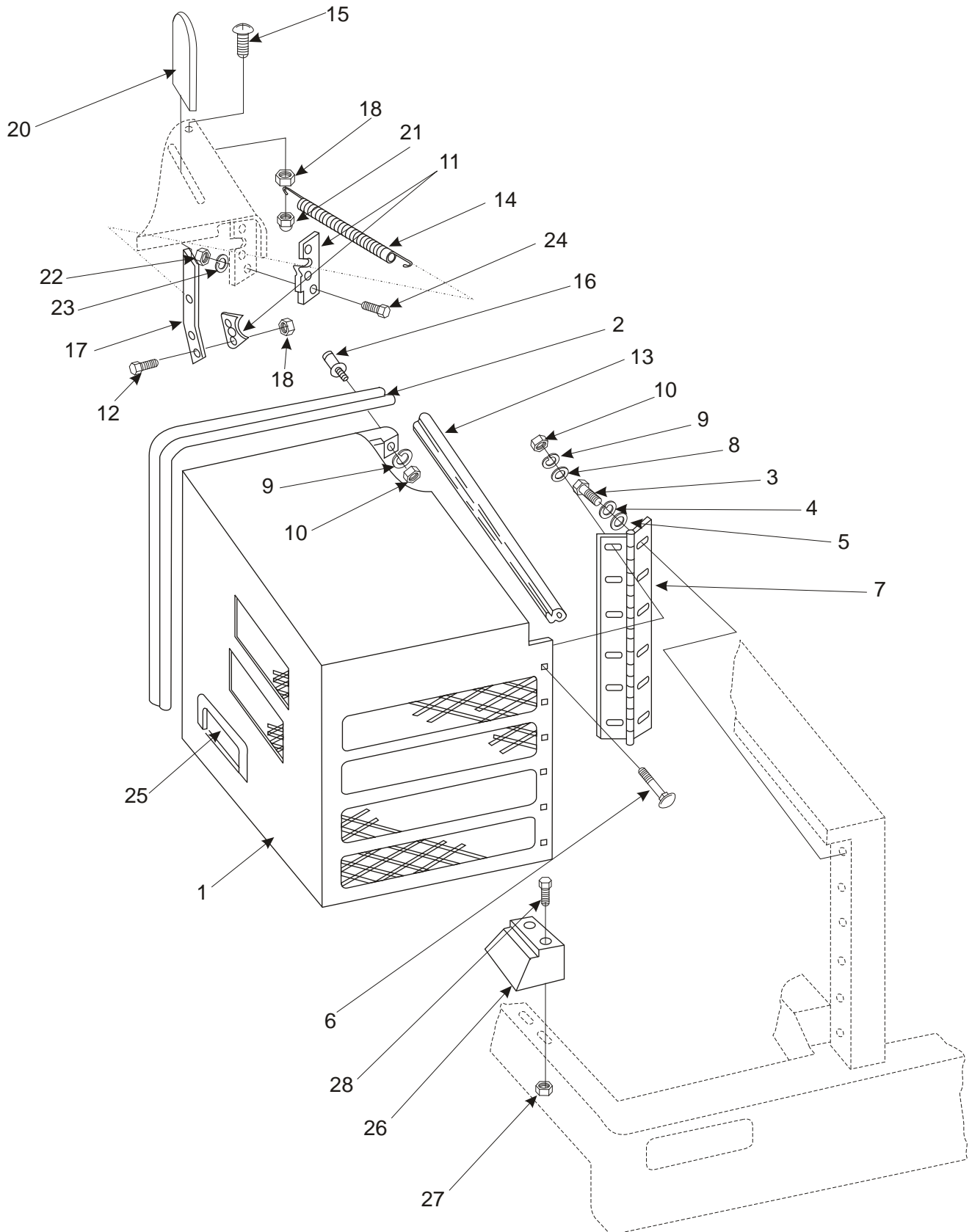

Item	Ref. No.	Qty	Description
1	56516812	1	Engine Cover Weldment
2	8-21-04043	1	Edging, Engine Compartment Seal
3	2-00-00233	6	Screw, 3/8 - 16 x 1.00 HHC
4	2-00-02310	6	Lock Washer, Helical Spring 3/8 Med
5	2-00-04801	6	Flat Washer, .875 x .375 x .062
6	2-00-03569	6	Carriage Bolt, 5/16-18 x .750
7	56516813	1	Engine Cover Hinge
8	2-00-00409	6	Flat Washer, 5/16 x .69
9	2-00-00530	7	Lock Washer, Helical Spring 5/16
10	2-00-00585	7	Nut, Hex 5/16-18
11	8-41-00046	1	Rotary Latch
12	2-00-04794	2	Screw, #10-24 x .625 BHS
13	8-21-04042	1	Edging, Engine Compartment Seal
14	7-76-00106	1	Lever Return Spring
15	2-00-03063	1	Screw, #10-24 x .750 THM
16	7-55-08116	1	Striker Latch Pin
17	56516815	1	Latch Release Lever
18	2-00-01246	3	Insert, #10 - 24 Thin Nylon
20	7-31-06061	1	Lever Cover
21	2-00-01246	1	Nut, Hex Fibre Lock #10-24
22	2-00-00594	3	Nut, Hex 1/4-20
23	2-00-00518	3	Lock Washer, Helical Spring 1/4
24	2-00-02587	3	Screw, 1/4-20 x 1.250 HHC
25	8-21-04038	1	Hand Hole Edging
26	7-78-05016	1	Engine Cover Stop
27	2-00-00641	2	Nut, Hex Fiber Lock 1/4-20
28	2-00-01769	2	Screw, 1/4-20 x 1.75 HHC

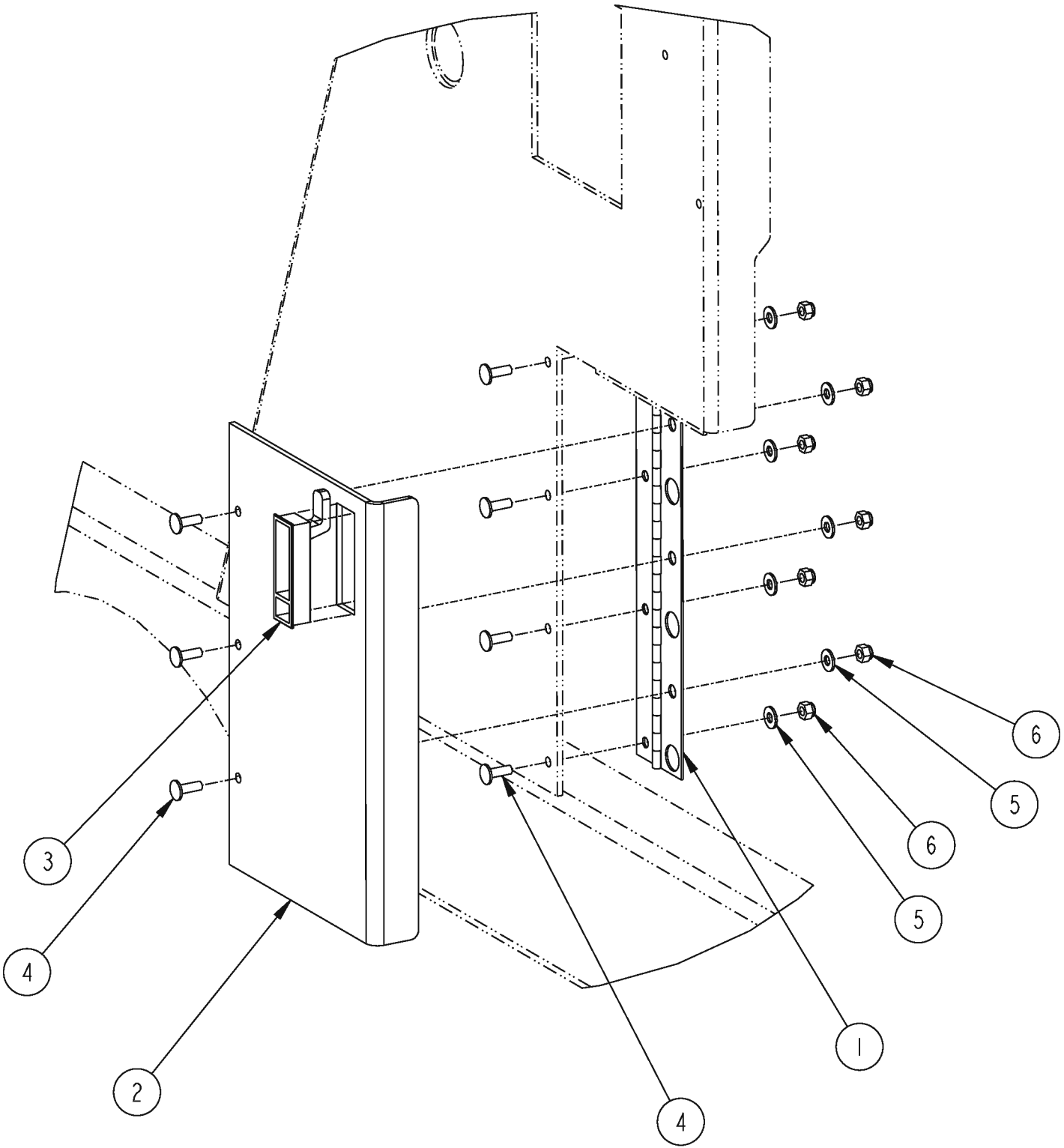

09-5

ENGINE ACCESS DOOR

Granterra

53

Item	Ref. No.	Qty	Description
1	7-89-06545	1	Hinge
2	56516831	1	Door, Lintel
3	8-41-00044	1	Latch
4	2-00-00183	7	Screw, 1/4-20 x 3/4 Round Head
5	2-00-03702	7	Washer, .625 x .281 x .063
6	2-00-00641	7	Nut, 1/4-20 Fiber Insert

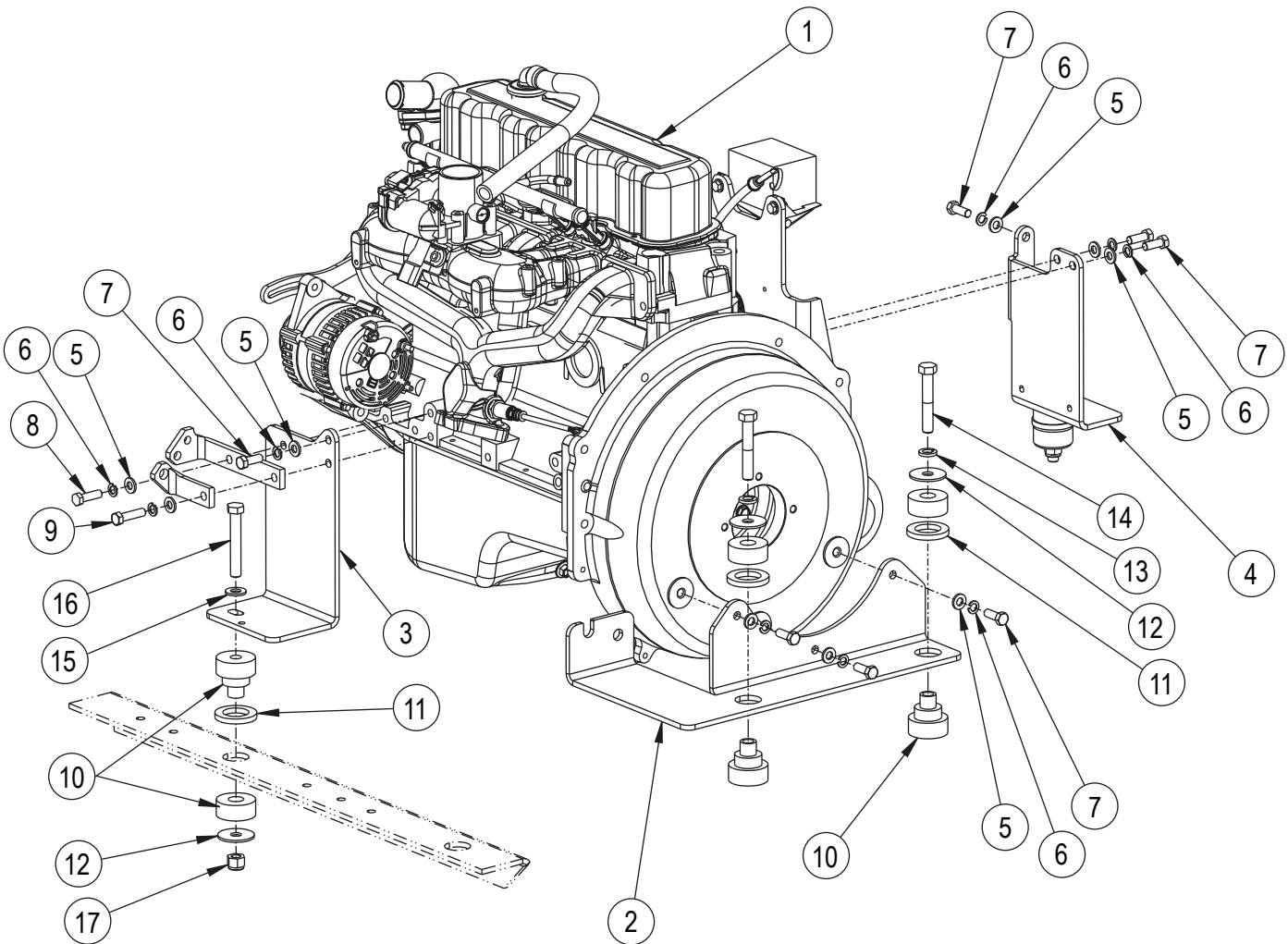

Item	Ref. No.	Qty	Description
1		1	Engine, GM 3.0 LPG (not available for sale)
*	56504513	1	Engine-Long Block Assy-3.0L
2	8-08-00966	1	Bracket, Engine Mount
3	8-08-00967	1	Bracket, Engine Mount
4	8-08-00968	1	Bracket, Engine Mount
5	2-00-00402	9	Washer, 25/64 ID x 3/4 OD
6	2-00-02310	9	Lock Washer, 3/8 Helical Spring
7	2-00-00233	7	Bolt, 3/8-16 x 1.25 Fin. Hex Head
8	2-00-00209	1	Bolt, 3/8-16 x 1.25 Hex Head
9	2-00-00234	1	Screw, 3/8-16 x 1.50 HHC
10	7-35-00017	4	Isolator, Engine Mount (Red Dot)
11	2-00-05955	4	Washer
12	2-00-05067	4	Spacer, Snubbing Washer
13	2-00-02312	2	Lock Washer, 1/2"
14	2-00-02697	2	Screw, 1/2-20 x 3.0
15	2-00-00405	2	Flat Washer, 1.063 x .531 x .094
16	2-00-02617	2	Screw, 1/2-13 x 3.5 SS
17	2-00-04936	2	Nut, 1/2-13 Elastic Lock

Item	Ref. No.	Qty	Description	Item	Ref. No.	Qty	Description
			Engine Replacement Parts				Engine Replacement Parts
*	56109000	1	Ecu, 06 Lp Cert 3.0l NOTE 1	*	56305867	1	Alternator
*	56109001	1	Ecu, 06 Gas Cert 3.0l NOTE 2	*	56109028	1	Belt, Alternator
*	56109113	1	Ecu, 07 Lp Cert 3.0l NOTE 1	*	56109029	1	Thermostat
*	56109114	1	Ecu, 07 Gas Cert 3.0l NOTE 2	*	56109030	1	Gasket, Thermostat
*	0795-225	1	Harness, 3.0l Lp Engine NOTE 1	*	56109032	1	Gasket, Thermostat Housing
*	0795-228	1	Harness, 3.0l Gas Engine NOTE 2	*	56109033	1	Throttle Body, Bosch 40mm
*	0795-220	1	Harness: Engine - Machine Patch	*	56109034	1	Gasket, Throttle Body
*	56109002	1	Sensor, Coolant	*	56109035	1	Mixer, Impco Model 100 NOTE 1
*	56109003	1	Sensor, Crankshaft Position	*	56109036	1	Gasket, Adapter - Mixer NOTE 1
*	56305405	1	Sensor, Tmap	*	56109040	1	Adapter, Mixer - Throttle Body NOTE 1
*	56109005	1	Sensor, O2 Pre Cat	*	56109041	2	Seal, Mixer Adapter NOTE 1
*	56109006	1	Switch, Oil Pressure	*	56109042	1	O-Ring, Mixer Adapter NOTE 1
*	8-69-00013	1	Sender, Water Temp	*	56109043	1	Electronic Pressure Regulator (EPR) NOTE 1
*	8-69-00005	1	Sender, Oil Pressure	*	56504540	1	Bracket-EPR Mounting NOTE 1
*	56109007	1	Water Pump	*	56109044	1	Sender, LPG Temp - EPR NOTE 1
*	56109008	1	Oil Pump	*	56109045	1	Fitting Kit, EPR NOTE 1
*	56109009	1	Gasket, Cylinder Head	*	56109046	3	Isolator, EPR NOTE 1
*	56109010	1	Gasket, Valve Cover	*	56109047	1	Hose, Water - EPR NOTE 1
*	56109011	1	Gasket, Lifter Cover	*	7-88-00110	1	Valve, Lp Safety NOTE 1
*	56109012	1	Gasket, Intake Manifold	*	56109048	1	Connector, Safety Valve NOTE 1
*	56109013	1	Plate, Drive, Sae 13t B-B	*	56109049	1	Lock, Safety Valve Connector NOTE 1, NOTE 3
*	56109014	6	Bolt, Drive Plate	*	56305410	1	Filter, Propane NOTE 1, NOTE 3
*	56109015	1	Distributor Assembly	*	56508936	1	Valve-Fuel-Lockoff NOTE 1, NOTE 4
*	56109016	1	Distributor Cap	*	56508939	1	LPG Filter Cartridge NOTE 1, NOTE 4
*	56109017	1	Distributor Rotor	*	56109050	1	Fuel Rail Assy NOTE 2
*	56109018	1	Ignition Module	*	56109051	1	Fuel Injector NOTE 2
*	56109019	1	Ignition Coil	*	56109185	1	Intake Manifold
*	56109020	1	Coil Wire	*	56109186	1	Exhaust Manifold
*	56109021	1	Spark Plug Wire Set	*	56504459	1	Front Crankshaft Seal
*	56109022	4	Spark Plug	*	56504475	1	Hose-Breather Cap
*	56109023	1	Oil Filter	*	56504476	1	Sender-Water Temp
*	56504509	1	Gasket-Oil Pan	*	56504474	1	Cap-Oil Fill
*	56109024	1	PCV Valve	*	56504541	1	Fitting-2 In. Pipe Nipple NOTE 1
*	56109025	1	Starter	*	56381943	1	Outlet-Water 3.0l Gm
*	56109026	2	Bolt, Starter	*	56381950	1	Bolt Head
				*	56382691	1	Housing-Thermostat 3.0l Gm
				*	56109084	A/R	Engine Service Kit

* = Not Shown

NOTE 1: LPG models only**NOTE 2:** Gasoline / Petrol models only**NOTE 3:** Used on machines up to Serial No. 1000036509.**NOTE 4:** Used on machines Serial No. 1000036509 and above.

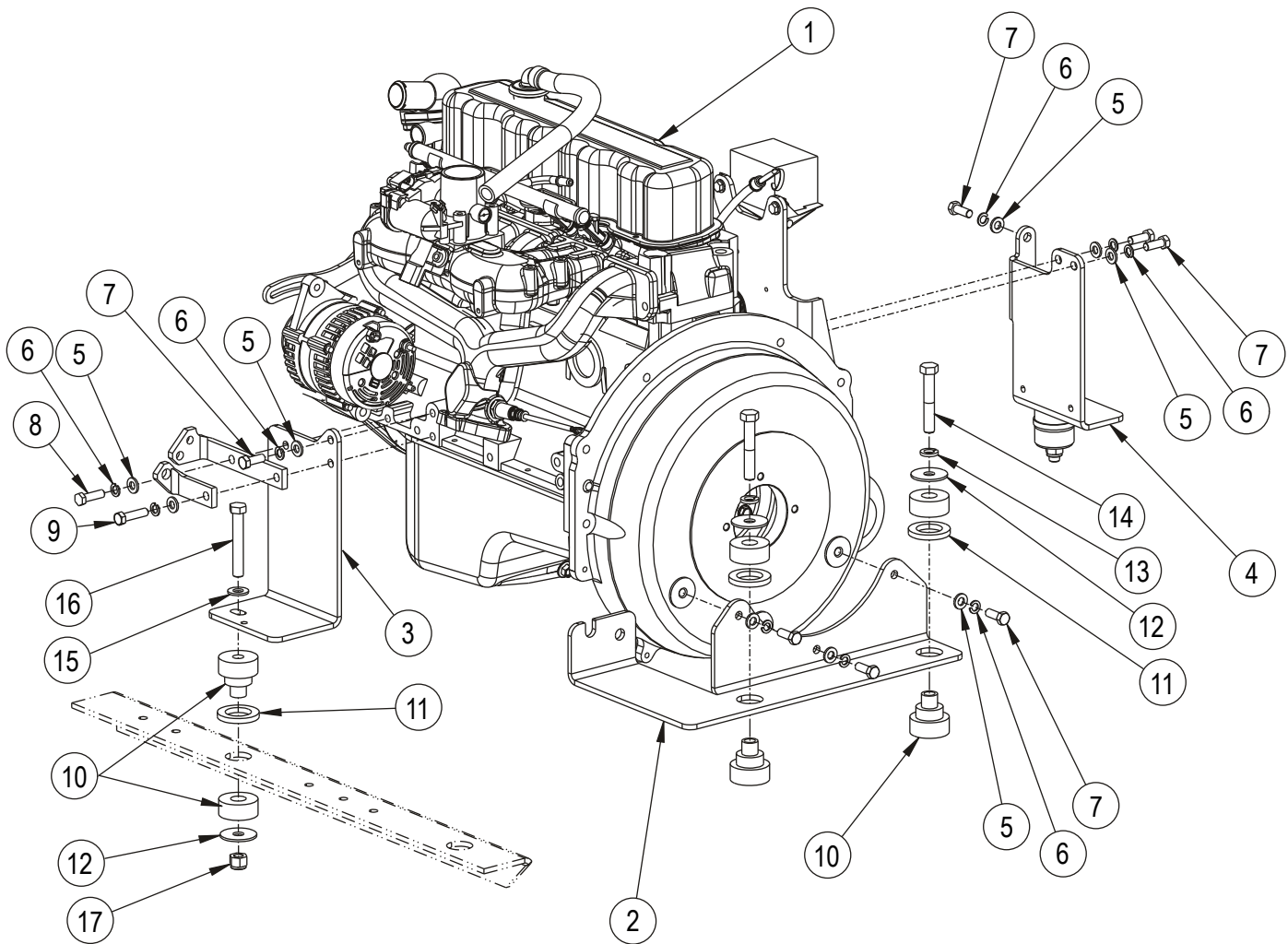

Item	Ref. No.	Qty	Description
1	56380126	1	Engine-PSI, GM 3.0 LP (PSI)
	56380127	1	Engine-PSI, GM 3.0 GAS (PSI)
*	56504513	A/R	Engine-Long Block Assy-3.0L
2	8-08-00966	1	Bracket, Engine Mount
3	8-08-00967	1	Bracket, Engine Mount
4	8-08-00968	1	Bracket, Engine Mount
5	2-00-00402	9	Washer, 25/64 ID x 3/4 OD
6	2-00-02310	9	Lock Washer, 3/8 Helical Spring
7	2-00-00233	7	Bolt, 3/8-16 x 1.25 Fin. Hex Head
8	2-00-00209	1	Bolt, 3/8-16 x 1.25 Hex Head
9	2-00-00234	1	Screw, 3/8-16 x 1.50 HHC
10	7-35-00017	4	Isolator, Engine Mount (Red Dot)
11	2-00-05955	4	Washer
12	2-00-05067	4	Spacer, Snubbing Washer
13	2-00-02312	2	Lock Washer, 1/2"
14	2-00-02697	2	Screw, 1/2-20 x 3.0
15	2-00-00405	2	Flat Washer, 1.063 x .531 x .094
16	2-00-02617	2	Screw, 1/2-13 x 3.5 SS
17	2-00-04936	2	Nut, 1/2-13 Elastic Lock

Item	Ref. No.	Qty	Description	Item	Ref. No.	Qty	Description
			Engine 3.0L GM (PSI)				GAS/PETROL ONLY
*	0795-220	1	Harness: Engine - Machine Patch	*	56383130	1	Harness-Main 3.0L GM Gas
*	56109002	1	Sensor, Coolant	*	56109033	1	Throttle Body, Bosch 40mm
*	56109003	1	Sensor, Crankshaft Position	*	56109050	1	Fuel Rail Assembly
*	56305405	1	Sensor, Map	*	56109051	4	Fuel Injector
*	7-11-04081	1	Sensor-O2	*	56380128	1	Ecu-Psi 3.0l Gas
*	56380238	1	Sender-3.0l Oil Pressure	*	0795-226	1	Harness, Fuel Temp Extension
*	8-69-00013	1	Sender, Water Temp	*	56305062	1	Fuel Pump
*	8-69-00005	1	Sender, Oil Pressure	*	56109052	1	Fitting, Fuel Pump
*	56109007	1	Water Pump	*	56305412	1	Fuel Filter
*	56109008	1	Oil Pump	*	7-11-04082	1	Manifold, Fuel Temp - Return
*	56109010	1	Gasket, Valve Cover	*	7-11-04083	4	Fitting, -6 Stor - 5/16 Sae J2044
*	56109011	1	Gasket, Lifter Cover	*	7-11-04084	1	Fitting, -3 Stor - 5/16 Sae J2044
*	56109012	1	Gasket, Intake Manifold				LPG ONLY
*	56109013	1	Plate, Drive, Sae 13t B-B	*	56383231	1	Harness-Main 3.0L GM LP
*	56109014	6	Bolt, Drive Plate	*	56380129	1	Ecu-Psi 3.0l Lp
*	56109015	1	Distributor Assembly	*	56380136	1	Depr-Psi 3.0l
*	56109016	1	Distributor Cap	*	56380138	1	Regulator-Dual Stage
*	56109017	1	Distributor Rotor	*	56109207	1	Adapter-3.0l Mixer
*	56109018	1	Ignition Module	*	56111892	1	Elbow-90 Deg Reducer
*	56109019	1	Ignition Coil	*	56380151	1	Hose-Intake
*	56109020	1	Coil Wire	*	56109206	1	Body-3.0l Throttle
*	56109021	1	Spark Plug Wire Set	*	56380145	1	Mixer-Psi 3.0l Lpg
*	56109022	4	Spark Plug	*	56109041	2	Seal, Mixer Adapter
*	56109023	1	Oil Filter	*	56109042	1	O-Ring, Mixer Adapter
*	56109205	1	Valve-Pcv	*	56109044	1	Sender, Lpg Temp - Epr
*	56109025	1	Starter	*	56109045	1	Fitting Kit, Epr
*	56109026	2	Bolt, Starter	*	56109046	3	Isolator, Epr
*	56305867	1	Alternator	*	56109048	1	Connector, Safety Valve
*	56109028	1	Belt, Alternator	*	56109049	1	Lock, Safety Valve Connector
*	56109029	1	Thermostat, 180°F	*	56508936	1	Valve-Fuel Lockoff
*	56109030	1	Gasket, Thermostat	*	56508939	1	Cartridge-Lpg Filter
*	56109032	1	Gasket, Thermostat Housing	*	56109208	1	Manifold-3.0l Intake
*	56109034	1	Gasket, Throttle Body				
*	56381943	1	Outlet-Water 3.0l Gm				
*	56381950	1	Bolt Head				
*	56382691	1	Housing-Thermostat 3.0l Gm				
*	56109084	A/R	Engine Service Kit				

* = Not Shown

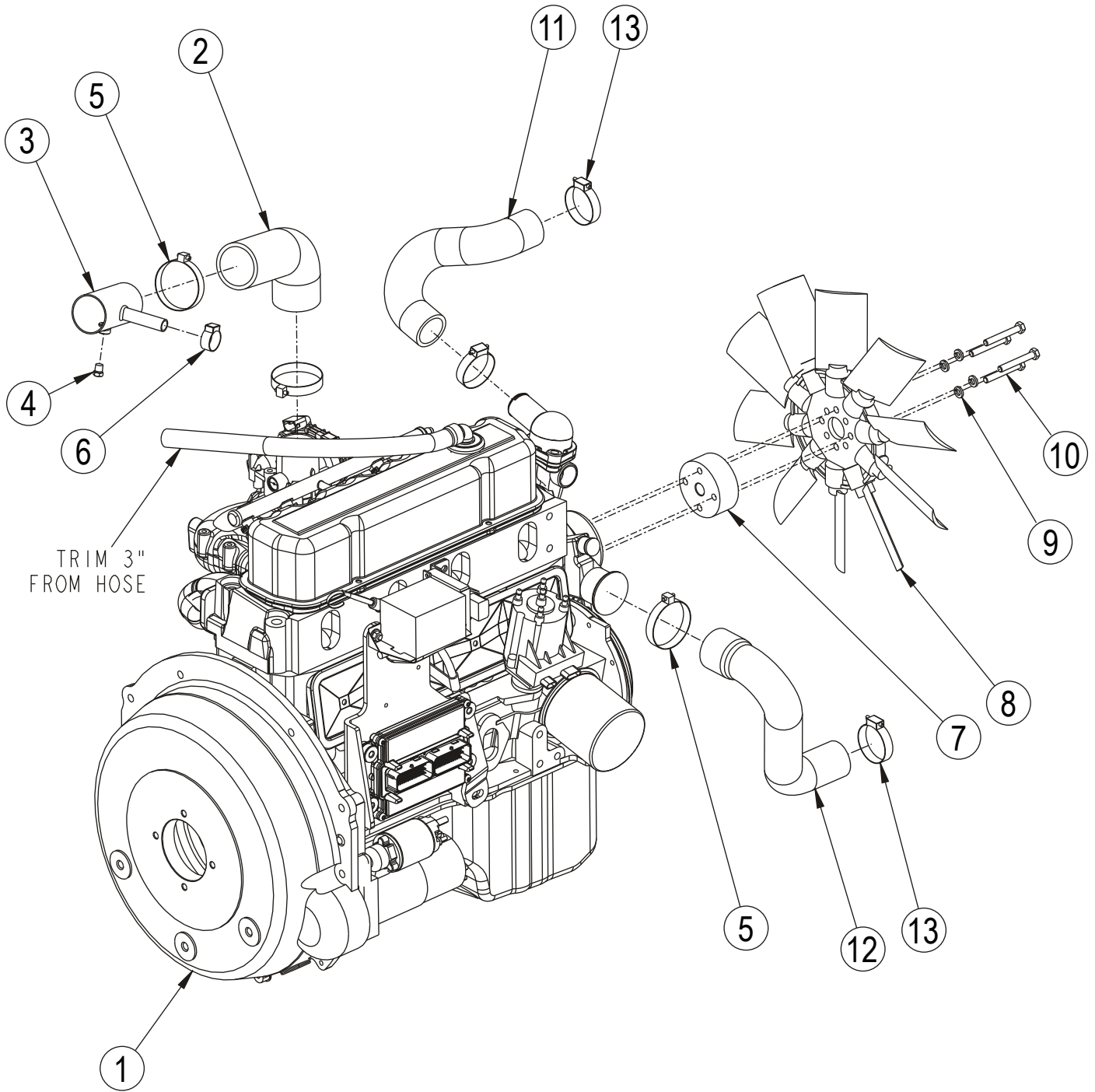

09-5

GM 3.0 LITER - GAS ENGINE [FAN, AIR INTAKE & RADIATOR HOSES]

11-7

Granterra**59**

Item	Ref. No.	Qty	Description
1		1	Engine, GM 3.0 GAS (IMPCO) (not available for sale)
	56380127	1	Engine-PSI, GM 3.0 GAS (PSI)
2	7-33-02712	1	Hose, Air Intake
3	56305240	1	Tube (Weldment)
4	2-00-03778	1	Plug, 1/8 NPT
5	2-00-02216	3	Clamp, Hose
6	2-00-03407	1	Clamp, Witteck #10P
7	7-75-01282	1	Spacer, Fan
8	8-23-00018	1	Fan, 15.5" Breeza
9	2-00-00530	4	Lock Washer, 5/16
10	2-00-06557	4	Screw, 5/16-24 x 2.25 Hex Head
11	8-33-02409	1	Hose, Upper Radiator
12	8-33-02410	1	Hose, Lower Radiator
13	2-00-03404	3	Clamp, Hose

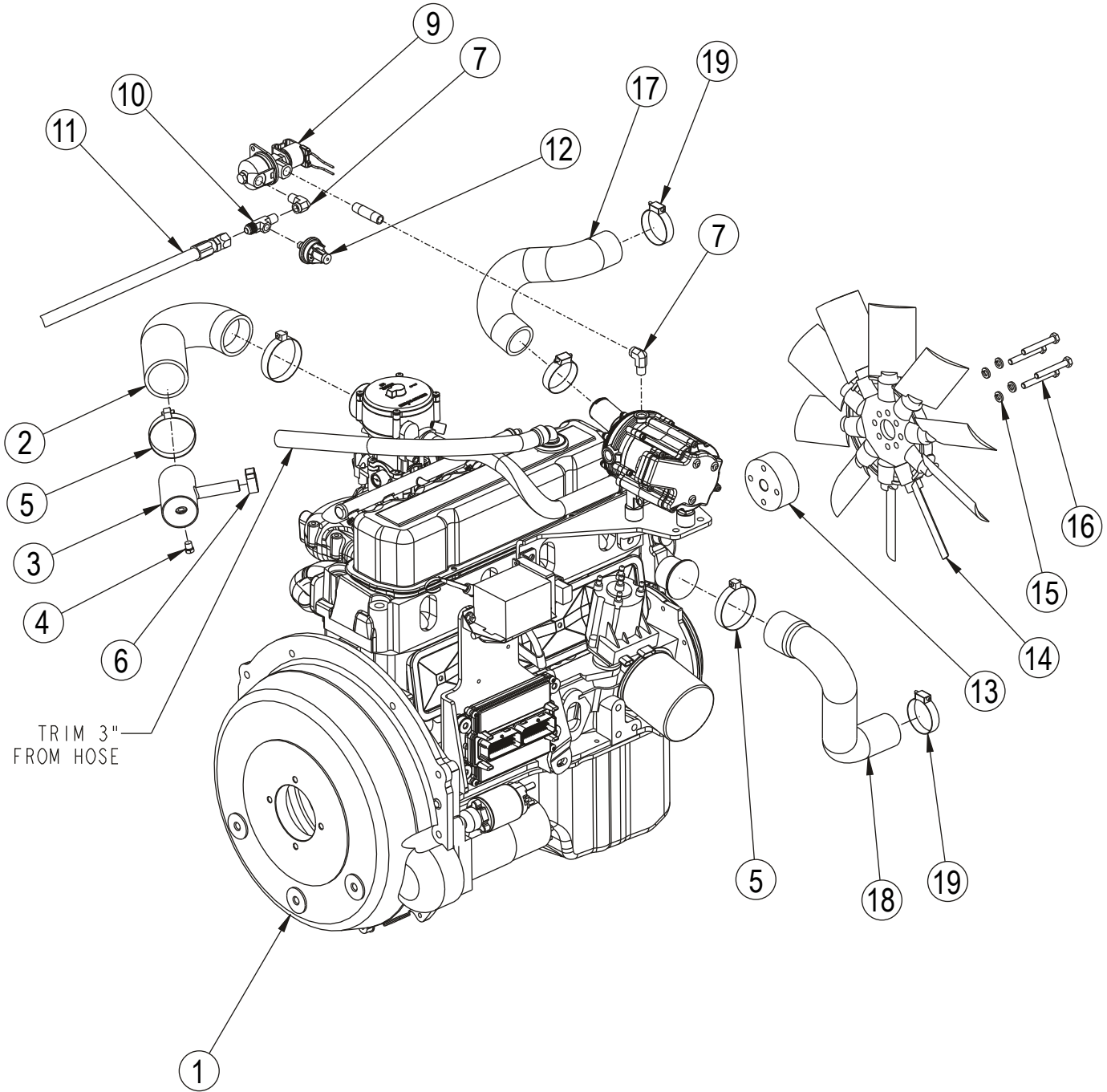

09-5	GM 3.0 LITER - LP ENGINE [FAN, AIR INTAKE & RADIATOR HOSES] IMPCO		
11-7	Granterra		61

Item	Ref. No.	Qty	Description
		1	Engine, GM 3.0 LP (IMPCO) (not available for sale)
2	8-33-02411	1	Hose, Air Intake
3	56305240	1	Tube (Weldment)
4	2-00-03778	1	Plug, 1/8 NPT
5	2-00-02216	3	Clamp, Hose
6	2-00-03407	1	Clamp, Witteck #10P
7	2-00-05678	1	Fitting, 1/4" NPT 90° Brass Street Elbow
9	7-88-00110	1	Valve, LP Safety (included with 0777-068)
10	56900921	1	Fitting, 1/4 NPT x 1/8 NPT x 3/8 JIC Tee
11	8-33-02415	1	Hose, LP High Pressure (102")
12	56418381	1	Switch-Low Pressure
13	7-75-01282	1	Spacer, Fan
14	8-23-00018	1	Fan, 15.5" Breeza
15	2-00-00530	4	Lock Washer, 5/16
16	2-00-06557	4	Screw, 5/16-24 x 2.25 Hex Head
17	8-33-02409	1	Hose, Upper Radiator
18	8-33-02410	1	Hose, Lower Radiator
19	2-00-03404	3	Clamp, Hose

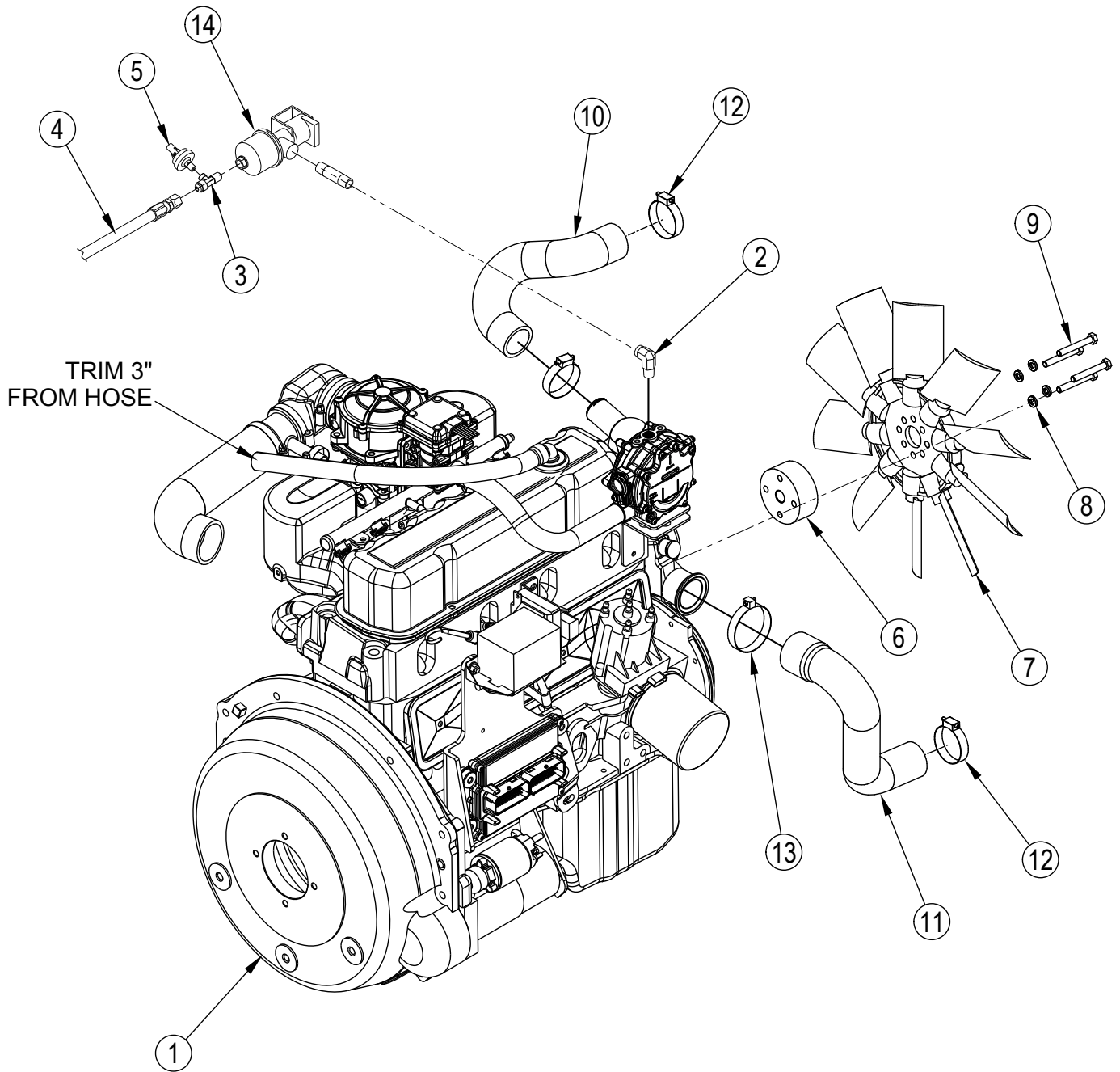

09-5

GM 3.0 LITER - LP ENGINE [FAN, AIR INTAKE & RADIATOR HOSES] PSI

12-11

Granterra

63

Item	Ref. No.	Qty	Description
1	56380126	1	Engine-PSI, GM 3.0 LP (PSI)
2	2-00-05678	1	Fitting, 1/4" NPT 90° Brass Street Elbow
3	56900921	1	Fitting, 1/4 NPT x 1/8 NPT x 3/8 JIC Tee
4	8-33-02415	1	Hose, LP High Pressure (102")
5	56418381	1	Switch-Low Pressure
6	7-75-01282	1	Spacer, Fan
7	8-23-00018	1	Fan, 15.5" Breeza
8	2-00-00530	4	Lock Washer, 5/16
9	2-00-06557	4	Screw, 5/16-24 x 2.25 Hex Head
10	8-33-02409	1	Hose, Upper Radiator
11	8-33-02410	1	Hose, Lower Radiator
12	2-00-03404	3	Clamp, Hose
13	2-00-02216	1	Clamp, Hose
14	7-88-00110	1	Valve, LP Safety (included with 56380126)

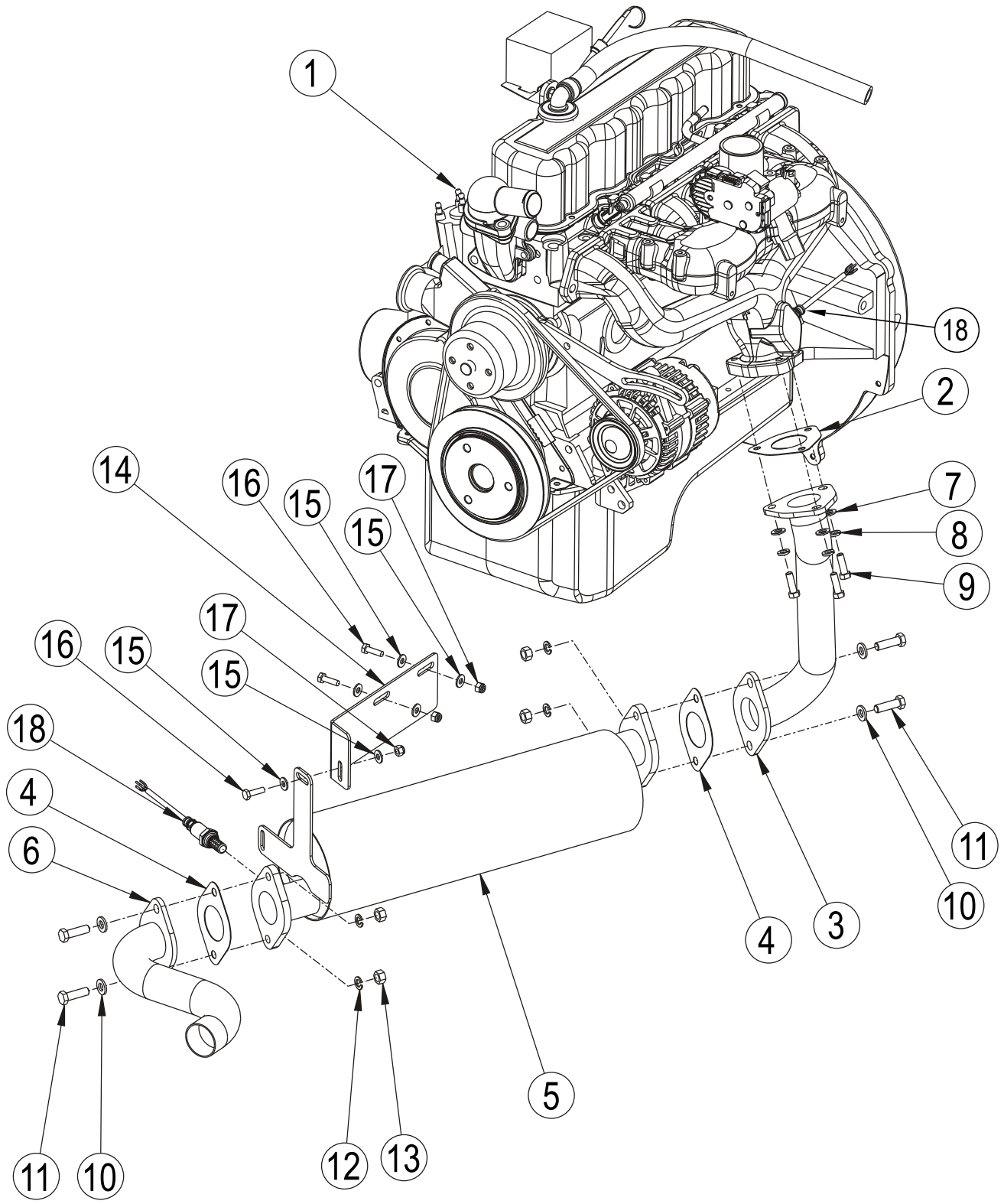

Item	Ref. No.	Qty	Description
1		1	Engine, GM 3.0 LP (IMPCO) (not available for sale)
		1	Engine, GM 3.0 GAS (IMPCO) (not available for sale)
1	56380126	1	Engine-PSI, GM 3.0 LP (PSI)
	56380127	1	Engine-PSI, GM 3.0 GAS (PSI)
2	7-29-00344	1	Gasket, Exhaust Flange NOTE 1
3	8-56-04060	1	Exhaust Downpipe
4	7-29-00345	2	Gasket, Exhaust Flange NOTE 1
5	7-49-00045	1	Muffler, Catalyst (Petrol & LPG) (IMPCO engines only) NOTE 1
	56109496	1	Catalytic Converter (Petrol & LPG) (PSI engines only) NOTE 1
6	8-56-04061	1	Exhaust Tailpipe
7	2-00-00409	3	Flat Washer, .687 x .344 x .062
8	2-00-00530	3	Lock Washer, 5/16
9	2-00-04948	3	Screw, M8 x 1.25 x 25mm HHC
10	2-00-00402	4	Washer, 25/64 ID x 3/4 OD
11	2-00-00209	4	Bolt, 3/8-16 x 1.25 Hex Head
12	2-00-02310	4	Lock Washer, 3/8 Helical Spring
13	2-00-02360	4	Nut, 3/8-16 Hex
14	8-31-07014	1	Hanger, Muffler
15	2-00-03702	6	Washer, .625 x .281 x .063
16	2-00-01490	3	Screw, 1/4-20 x .875 Hex Head
17	2-00-00641	3	Nut, 1/4-20 Fiber Insert
18	7-11-04081	2	O2 Sensor, GM 3.0 NOTE 1

NOTE 1: Shipped with the engine

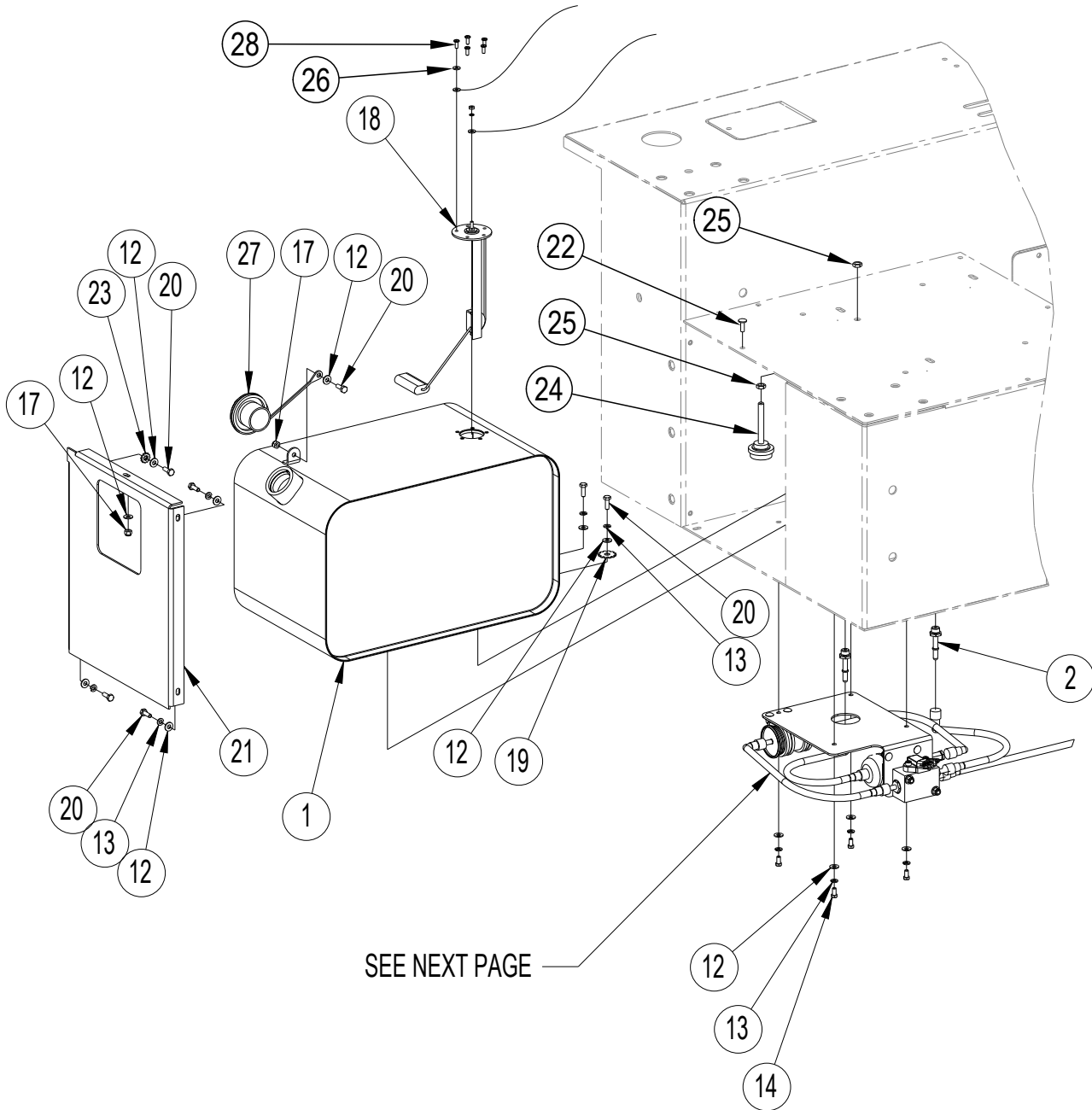

09-5	GM 3.0 LITER - GAS ENGINE [FUEL SYSTEM]		
12-11	Granterra		67

Item	Ref. No.	Qty	Description
1	56109112	1	Fuel Tank, Gas
2~	7-11-04083	4	Fitting, -6 SAE x 5/16 Quick Connect
3	8-08-00974	1	Bracket, Fuel System
4	7-13-07243	4	Clamp, Fuel Pump
5~	56305062	1	Fuel Pump
7~	56305412	1	Fuel Filter
8~	7-11-04082	1	Manifold, Fuel Temperature
9~	7-11-04084	1	Fitting, -3 SAE x 5/16 Quick Connect
10	8-33-02416	4	Fuel Line, Low Permeation
11	8-33-02417	1	Fuel Line, Low Permeation
12	2-00-03702	17	Washer, .625 x .281 x .063
13	2-00-00518	9	Lock Washer, 1/4" Helical Spring
14	2-00-00219	4	Bolt, 1/4-20 x 1/2 Hex Head
15	2-00-03575	4	Carriage Bolt, 1/4-20 x 3/4
16	2-00-00198	2	Carriage Bolt, 1/4-20 x 2.0
17	2-00-00641	7	Nut, 1/4-20 Fiber Insert
18	8-26-04003	1	Float, Fuel Level
19	2-00-03829	1	Lock Washer, 3/8" Int/Ext Tooth
20	2-00-00221	6	Bolt, 1/4-20 x 3/4 Fin. Hex Head
21	56516835	1	Rear Wall, Seat Compartment
22	2-00-00183	1	Screw, 1/4-20 x 3/4 round Head
23	2-00-00503	1	Lock Washer, 1/4-20
24	7-50-05144	1	Pad
25	2-00-02369	2	Nut, 3/8-16
26	56009011	1	WSH INT SHPRF 10
27	56508354	1	Cap
28	56002147	5	Scr Pan Phil 10-32 X .50

* = Not Shown
~Comes with 0777-069 Engine Assembly

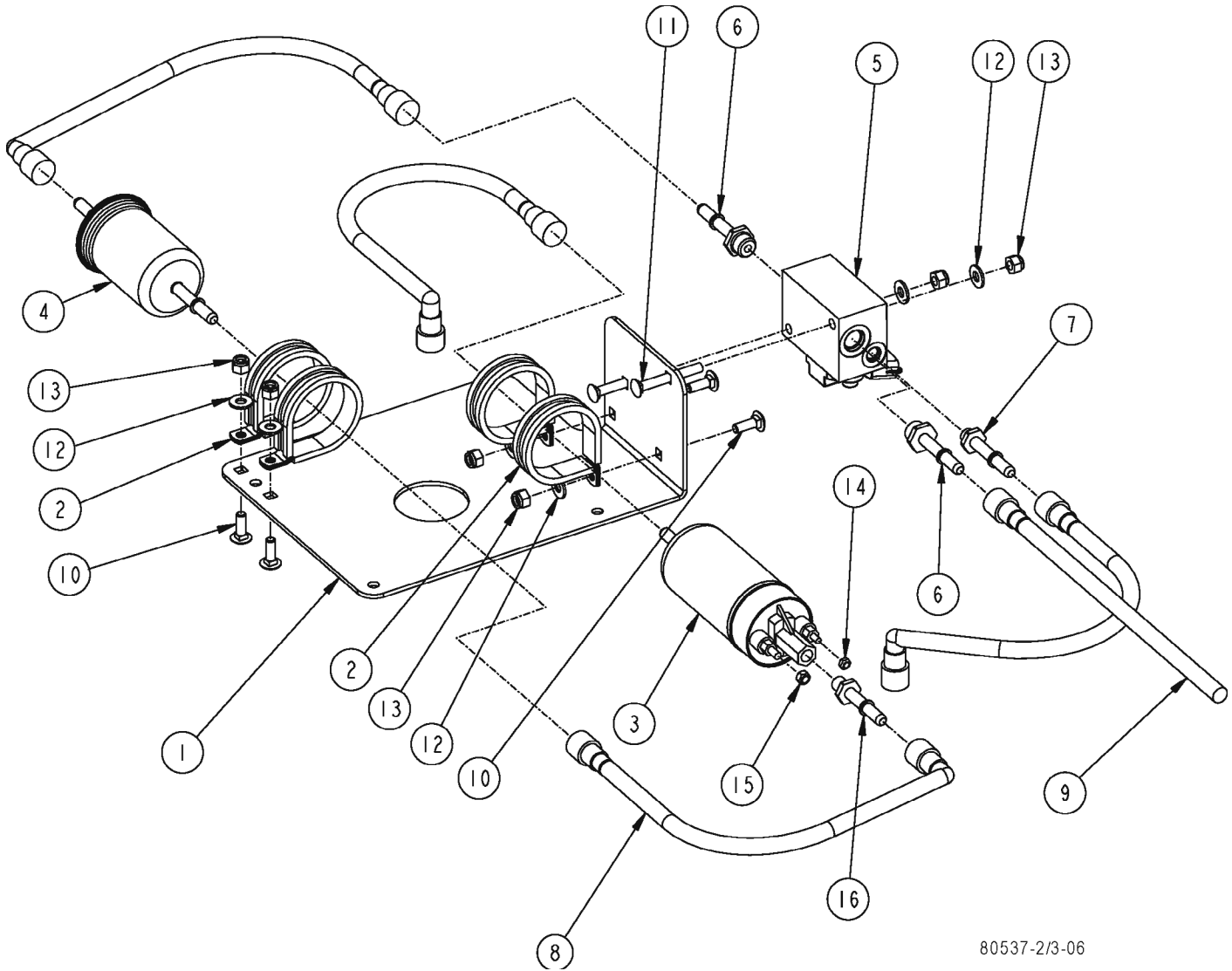

80537-2/3-06

Item	Ref. No.	Qty	Description
1	8-08-00974	1	Bracket, Fuel System
2	7-13-07243	4	Clamp, Fuel Pump
3~	56305062	1	Fuel Pump
4~	56305412	1	Fuel Filter
5~	7-11-04082	1	Manifold, Fuel Temperature
6~	7-11-04083	2	Fitting, -6 SAE x 5/16 Quick Connect
7~	7-11-04084	1	Fitting, -3 SAE x 5/16 Quick Connect
8	8-33-02416	4	Fuel Line, Low Permeation
9	8-33-02417	1	Fuel Line, Low Permeation
10	2-00-03575	4	Carriage Bolt, 1/4-20 x 3/4
11	2-00-00198	2	Carriage Bolt, 1/4-20 x 2.0
12	2-00-03702	6	Washer, .625 x .281 x .063
13	2-00-00641	6	Nut, 1/4-20 Fiber Insert
14	2-00-06572	1	Nut, M4 Distorted Thread
15	2-00-06573	1	Nut, M5 Distorted Thread
16~	56109052	1	Fitting, Fuel Pump

~Comes with 0777-069 Engine Assy.

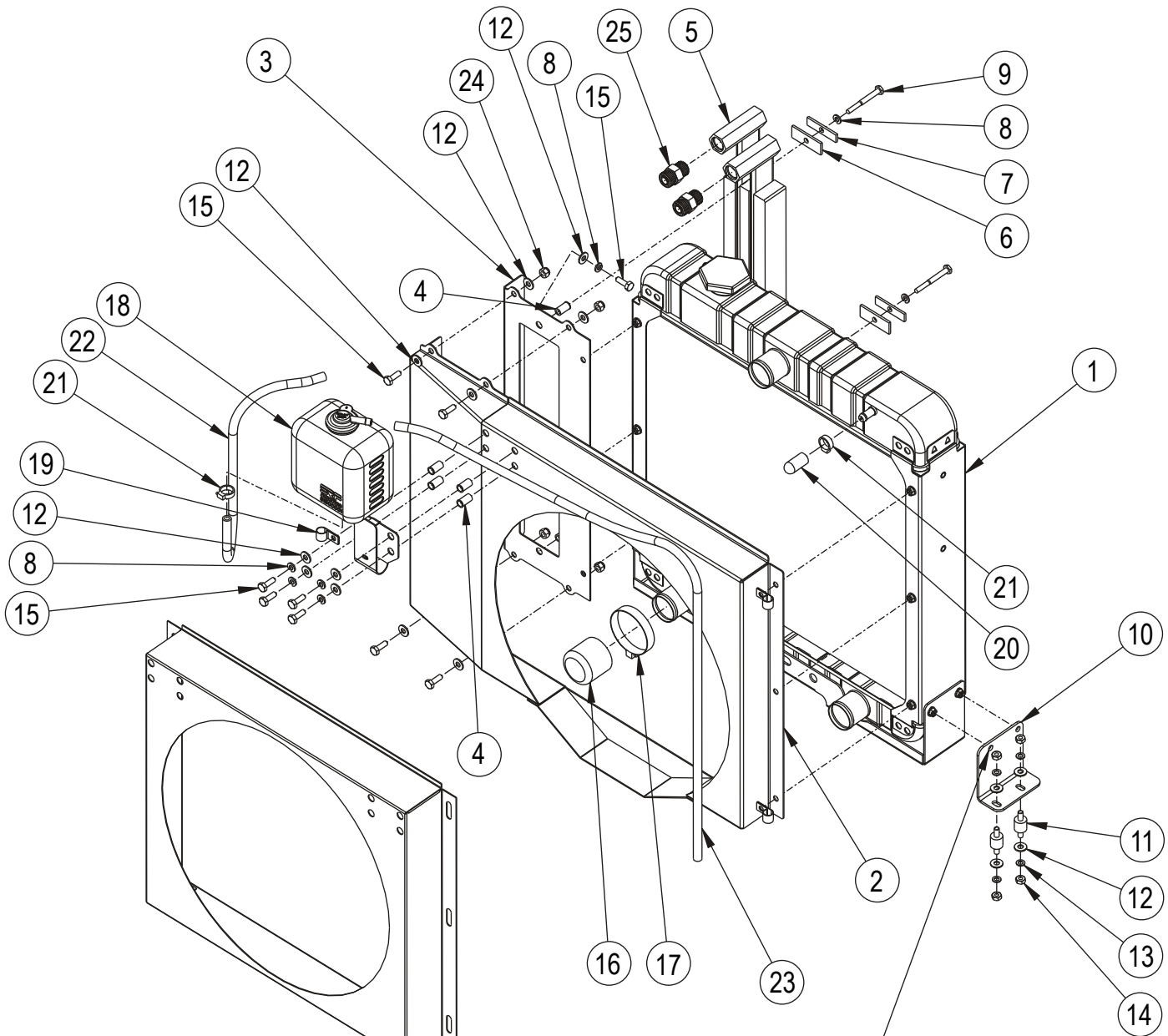

USE BOLTS THAT COME WITH RADIATOR

REMOVE SHROUD THAT COMES WITH RADIATOR 7-62-01008

09-5

RADIATOR ASSY - GM 3.0 LITER ENGINE [GASOLINE & LPG]

11-11

Granterra**71**

Item	Ref. No.	Qty	Description
1	7-62-01008	1	Radiator
2	8-72-00021	1	Shroud, Radiator
3	8-72-00022	1	Shroud, Oil Cooler
4	2-00-05261	6	Insert, 1/4-20 Threaded
5	8-62-01018	1	Oil Cooler
6	7-29-00192	2	Gasket, Oil Cooler
7	8-13-07088	2	Clip
8	2-00-00518	8	Lock Washer, 1/4" Helical Spring
9	2-00-00246	2	Bolt, 1/4-20 x 2.25 Hex Head
10	8-08-00946	1	Bracket, Radiator Mounting
11	8-50-05053	2	Isolator, Radiator Mount
12	2-00-03702	18	Washer, .625 x .281 x .063
13	2-00-00501	4	Washer, .25 ID x .44 OD x .046
14	2-00-00594	4	Nut, 1/4-20 Hex
15	2-00-00221	10	Screw, 1/4-20 x 3/4 HHC
16	2-00-05956	1	Plug, Radiator Outlet
17	56382616	1	Clamp Constant Tension
18	7-07-02002	1	Overflow Bottle Assy. (1 liter)
19	2-00-04602	3	Clamp
20	2-00-05985	1	Cap, 3/8 ID x 1 Inside Length (Rubber)
21	2-00-05363	2	Clamp, Hose
22	7-33-02642	1	Hose, 1/4" ID x 18" long (Black)
23	7-33-02643	1	Hose, 1/4" ID x 36" long (Black)
24	2-00-00641	4	Nut, 1/4-20 Fiber Insert
25	2-00-04970	2	Fitting, Str. -8 ORS x -8 SAE

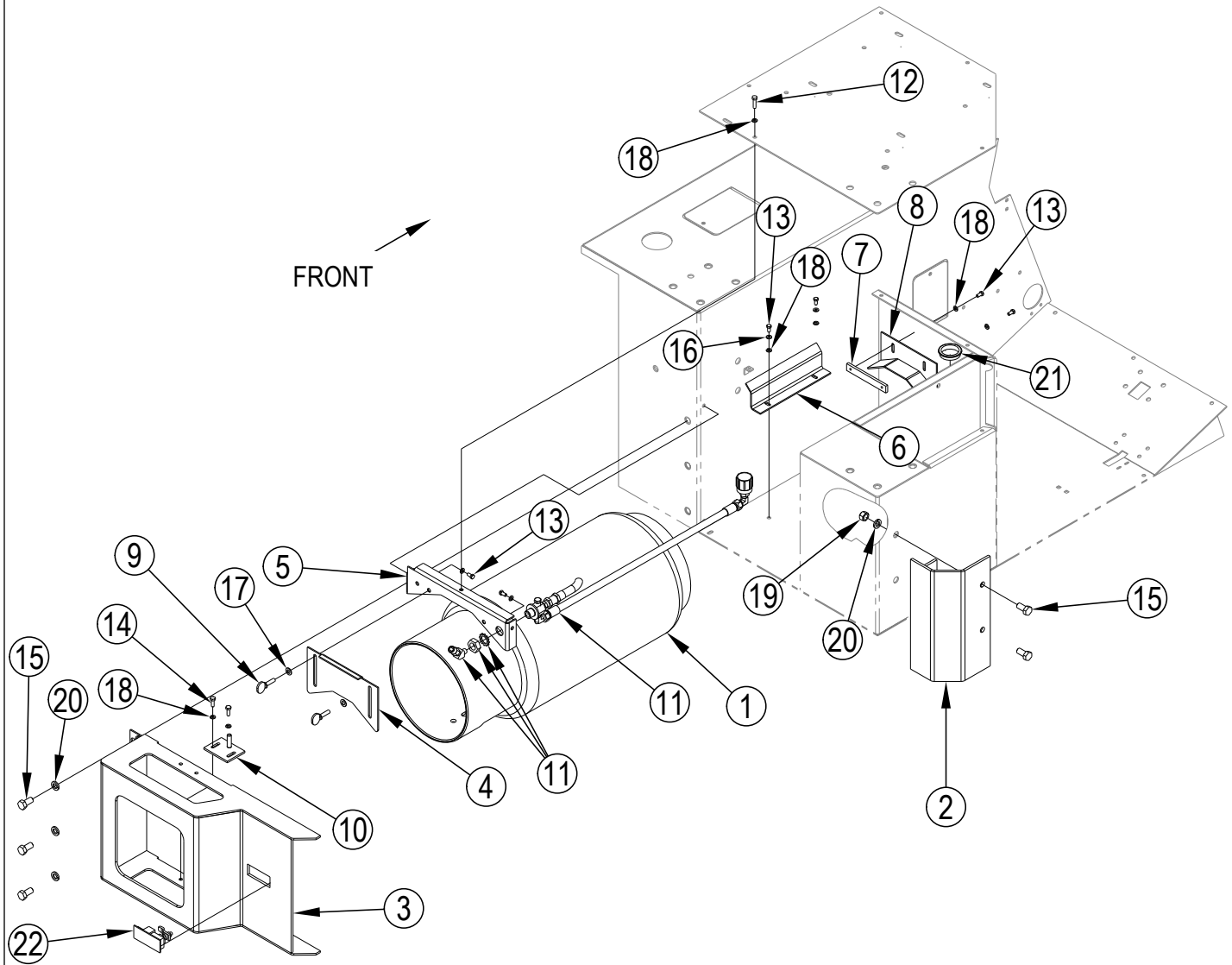

09-5

LP TANK SYSTEM

13-2

Granterra

73

Item	Ref. No.	Qty	Description
1	56456590	1	L.P. Tank, 33LB.
2	56516853	1	Weldment-Stop Lp Tank Bumper
3	56516854	1	Weldment-Bumper Lp Tank
4	56516855	1	Retainer-Lp Fuel Tank
5	56516856	1	Rear Wall-Seat Comp Lp
6	56516857	2	Weldment Support Leg Lp
7	56516858	1	Tap Bracket Lp Option
8	56516859	1	Retainer Rear Lp Tank
9	2-00-04867	2	Thumb Screw Shldr.313-18x1
10	8-08-00620	1	Brkt-Pin Locating 3366 Lp
11	8-11-04014	1	LP Tank Kit Option 3366xp
12	2-00-00205	1	Bolt-Hex Head, Finished, 1/4-20
13	2-00-00219	8	Bolt, Hex Head, Finished, 1/4-20
14	2-00-00221	2	Bolt-Hex Head, Finished, 1/4-20x3/4 Lg
15	2-00-00239	5	Screw, 1/2-13 X 1.000 HHC
16	2-00-00407	4	Washer, Flat 1/4
17	2-00-00409	2	Flat Washer, .687 X .344 X .062
18	2-00-00518	11	Washer,Lock,1/4" Helical Spring
19	2-00-00596	2	Nut, Hex Head, 1/2-13 X .44 Lg
20	2-00-02312	5	Washer, 1/2" Lock
21	8-09-01077	1	Grommet
22	8-41-00040	1	Latch

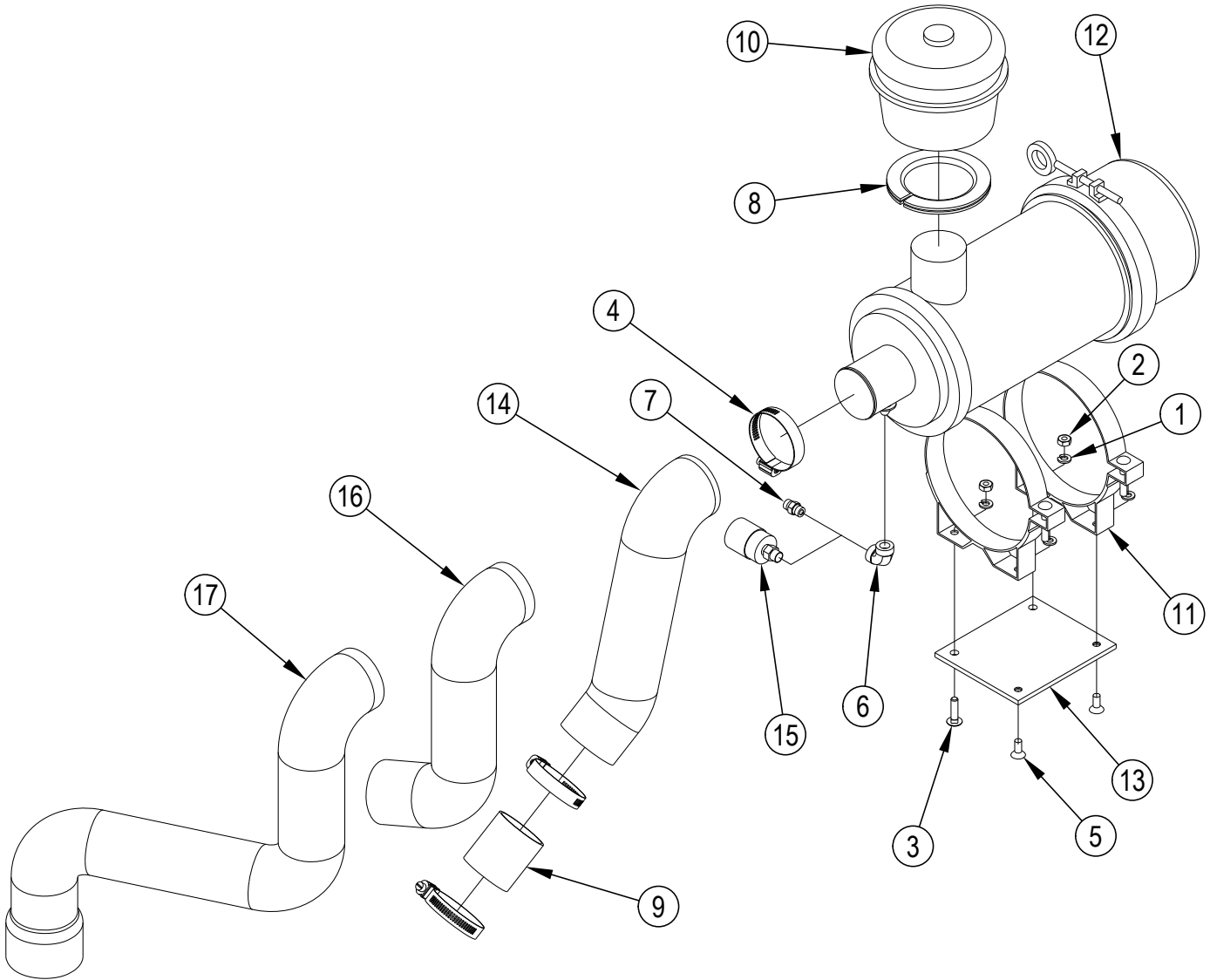

09-5	AIR CLEANER ASSY [GASOLINE, LPG, DIESEL]		
11-7	Granterra		75

Item	Ref. No.	Qty	Description
1	2-00-00518	4	Lock Washer, 1/4 Helical Spring
2	2-00-00594	4	Nut, 1/4-20 Hex
3	2-00-02196	2	Carriage Bolt, 1/4-20 x 1.00
4	2-00-02217	3	Clamp, Hose (qty of 2 on Gasoline / Petrol and Diesel)
5	2-00-03027	2	Screw, 1/4-20 x .63 Cap
6	2-00-03641	1	Elbow, 1/8 NPT
7	2-95-02519	1	Nipple-Close 1/8 NPT
8	7-21-04022	1	Edging
9	7-87-02203	1	Coupling (LPG)
10	8-24-04092	1	Filter, Dust Bowl
11	8-24-04093	2	Clamp, Air Cleaner
12	8-24-04100	1	Air Cleaner Assembly
	8-24-04106		Air Cleaner Element (exterior)
	8-24-04111		Air Cleaner Element (interior)
13	56516844	1	Plate, Filter Assy.
14	56381959	1	Hose, Intake (LPG)
15	56478461	1	Indicator, Service (Gasoline / Petrol & LPG)
	7-24-04087	1	Filter Service Indicator 20" WC (Diesel)
16	8-33-02413	1	Hose, Intake (Gasoline / Petrol)
17	8-33-02369	1	Hose, Intake (Diesel)

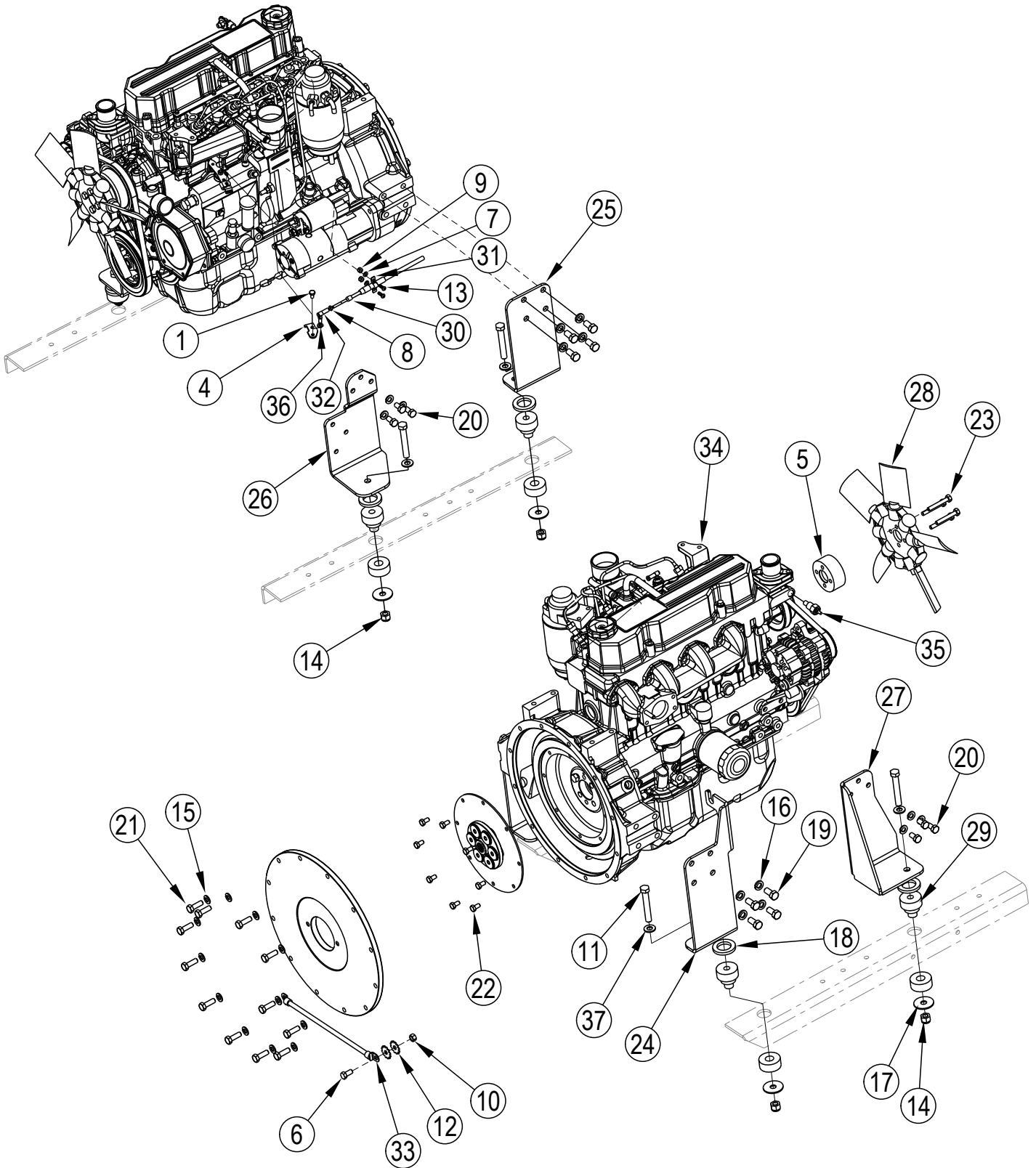

09-5	MITSUBISHI S4Q2 TIER 4 - DIESEL ENGINE [FAN, BRACKETS, THROTTLE]		
11-7	Granterra		77

Item	Ref. No.	Qty	Description	Item	Ref. No.	Qty	Description
1	56009033	1	Scr-Hex Thd Form 1/4-20 x .50	*	56109485	1	Fuel Filter Assembly
4	56109471	1	Arm Engine Throttle	*	56109487	1	Fuel Filter Element (for 56109485)
5	7-75-01248	1	Spacer, Fan Mitsubishi S4Q2	*	56109470	1	Bracket Throtle Cable Mtg
6	2-00-00232	1	Bolt-Hex Head, Finished, 3/8-16	*	56109481	1	Pipe Cylinder 1 S4Q2 T4
7	2-00-00426	2	Washer-Flat .500 X .219 X .063	*	56109482	1	Pipe Cylinder 2 S4Q2 T4
8	2-00-00626	1	10-32 Nut	*	56109483	1	Pipe Cylinder 3 S4Q2 T4
9	2-00-01246	2	Nut-#10-24 Elastic Stop Nut	*	56109484	1	Pipe Cylinder 4 S4Q2 T4
10	2-00-02360	1	Nut, Hex, 3/8-16	*	56109492	1	Pipe Return Fuel
11	2-00-02617	4	Screw, 1/2-13 X 3.5 Lg, SS	*	2-00-05968	1	Belt, Waterpump/Alternator Mitsu S4Q2
12	2-00-03829	2	Lock Washer, 3/8 Int./Ext. Tooth	*	7-24-04097	1	Filter, Oil Mitsubishi S4Q2
13	2-00-04794	2	Screw, #10-24 X .63 BHS	*	7-56-04079	1	Pipe, Balance Mitsubishi S4Q2
14	2-00-04936	4	Locknut-Elastic, 1/2-13	*	7-60-05048	1	Pump, Water Mitsubishi S4Q2
15	2-00-05042	18	M10 Helical Spring LW	*	7-75-03004	4	Glow Plug, Mitsubishi S4Q2
16	2-00-02312	8	Washer 1/2 Lock	*	0769-029	4	Injector, Mitsubishi S4Q2
17	2-00-05067	4	Spacer, Snubbing Washer	*	0775-285	1	Starter, Mitsubishi S4Q2
18	2-00-05955	4	Washer	*	0775-287	1	Alternator, Mitsubishi S4Q2
19	2-00-05957	8	HHC, M12 X 1.75 X 25mm	*	7-29-00312	1	Gasket, Thermostat Mitsubishi S4Q2
20	2-00-05958	6	HHC, M10 X 1.25 X 20mm	*	7-84-08016	1	Thermostat, Mitsubishi S4Q2
21	2-00-05961	12	HHC, M10 X 1.25 X 30mm				
22	2-00-05963	8	HHC, M8 X 1.25 X 15mm 8.8 Blox				
23	2-00-05981	4	HHC, M8 X 1.25 X 55mm				
24	7-08-01192	1	Bracket, Engine Mount				
25	7-08-01193	1	Bracket, Engine Mount				
26	7-08-01194	1	Bracket, Engine Mount				
27	7-08-01195	1	Bracket, Engine Mount				
28	7-23-00022	1	Fan, Mitsubishi S4Q2 Engine				
29	7-35-00017	4	Isolator, Engine Mount (Red Dot)				
30	8-10-00033	1	Cable-Throttle-57» LG.				
31	8-13-07094	1	Conduit Clamp				
32	8-25-02036	1	Ball Joint Connector				
33	8-90-07328	1	Wire, Ground To Frame				
34	56109479	1	Engine Assy, Mitsubishi S4Q2 T4				
35	8-69-00014	1	Sender, Water Temperature				
36	2-00-00518	1	Washer-Lock 1/4 Helical Spring				
37	2-00-00405	4	Flat Washer 1.063x.531x.094				

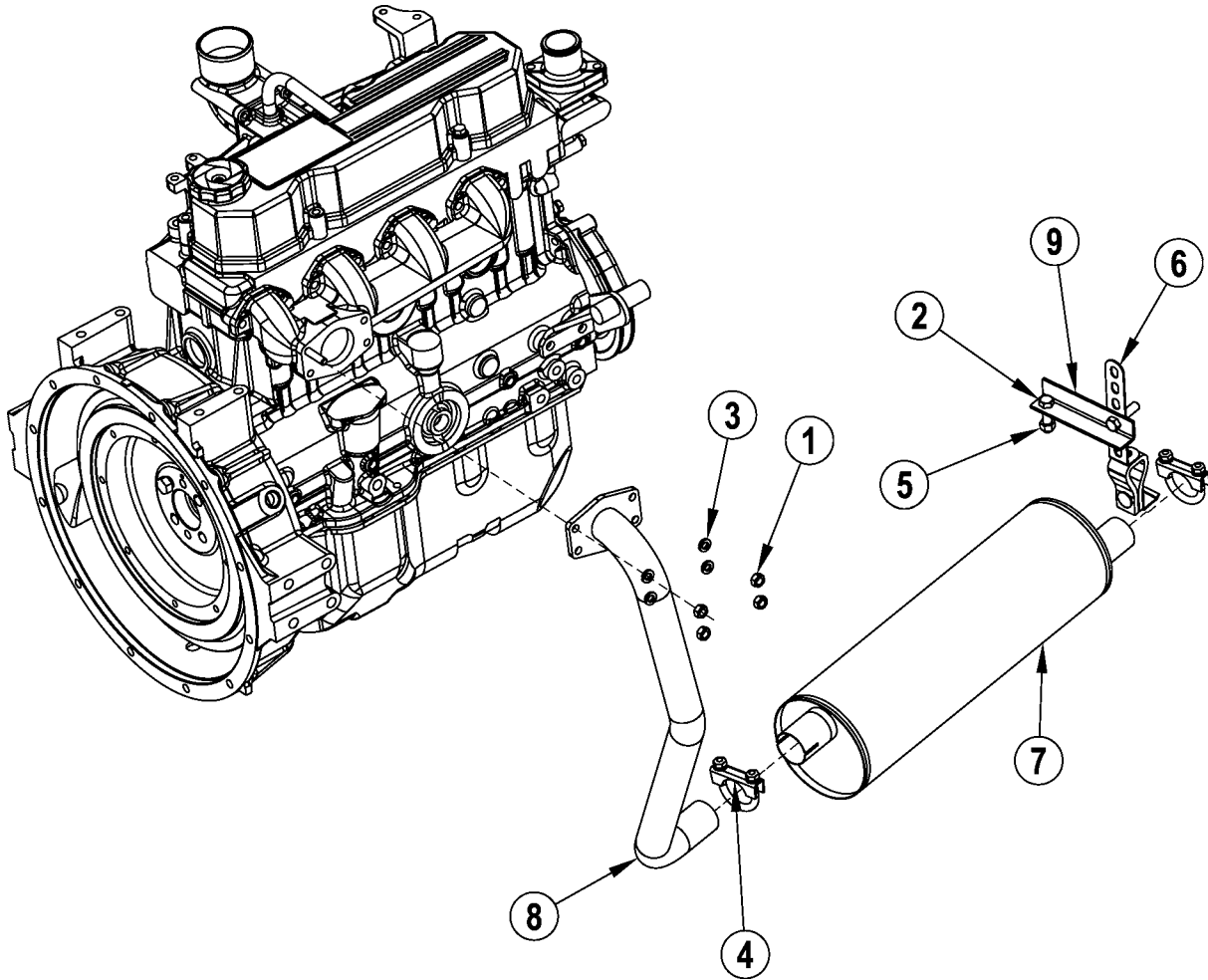

09-5

mitsubishi S4Q2 TIER 4 - DIESEL ENGINE (EXHAUST SYSTEM)**Granterra****79**

Item	Ref. No.	Qty	Description
1	56003352	4	Nut, Hex M8-1.25
2	2-00-00234	2	Screw, 3/8-16 X 1-1/2 HHC
3	2-00-00530	4	5/16" Lock Washer
4	2-00-04040	2	Clamp - Muffler 1 1/4
5	2-95-04182	2	Nut, Hex, Stop, 3/8-16
6	7-31-07017	1	Hanger-Muffler
7	7-49-00031	1	Muffler
8	7-87-02933	1	Tube, Exhaust
9	8-08-00861	1	Bracket, Muffler Hanger

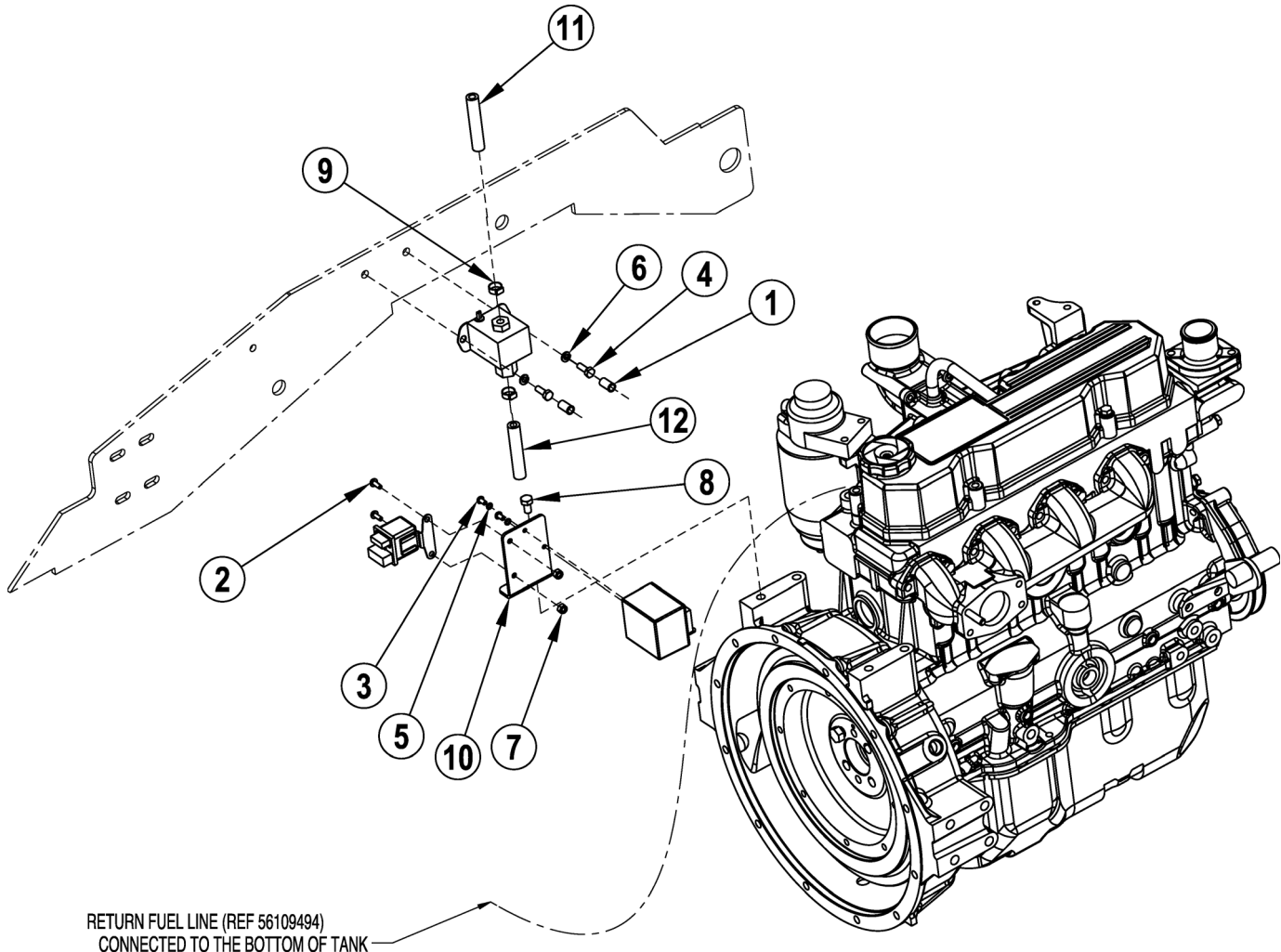

RETURN FUEL LINE (REF 56109494)
CONNECTED TO THE BOTTOM OF TANK

Item	Ref. No.	Qty	Description
1	2-00-05261	2	Nutsert, 1/4-20
2	2-00-00049	2	Scw-Rhm 10-24 X .50 Zn Pl
3	2-00-00052	2	Screw - #10-24 X .38 RHMS
4	2-00-00221	2	Bolt-Hex Head, Finished, 1/4-20 x 3/4 LG
5	2-00-00512	2	Washer, Star
6	2-00-00518	2	Washer, Lock, 1/4" Helical Spring
7	2-00-01246	2	Nut-#10-24 Elastic Stop Nut
8	2-00-05963	1	HHC, M8 X 1.25 X 15mm 8.8 Blox
9	2-95-04388	2	Clamp, Hose
10	8-08-00936	1	Bracket, Murphy
11	8-33-02154	1	Hose, Fuel
12	8-33-02338	1	Hose, Fuel

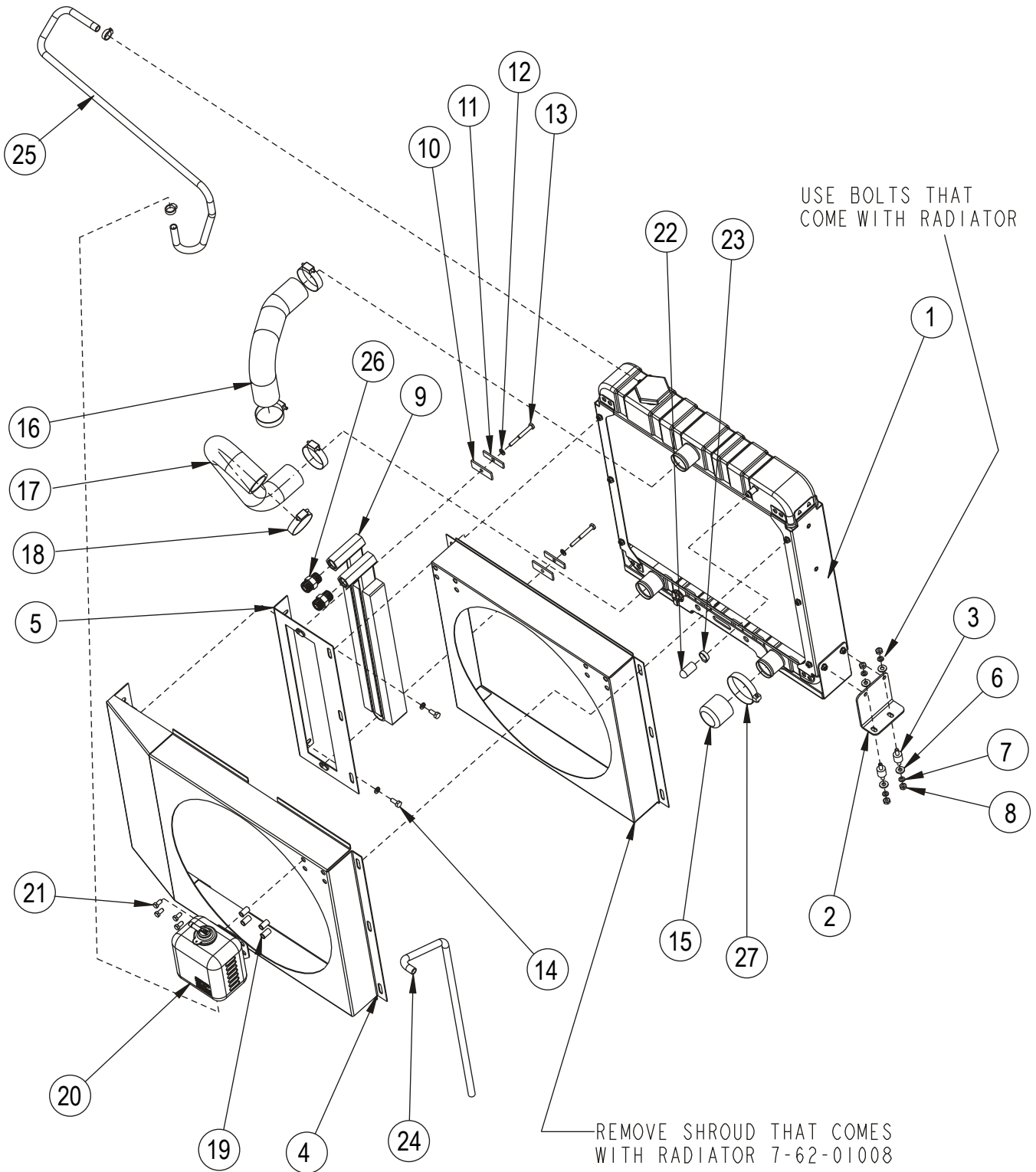

09-5

RADIATOR ASSY [DIESEL]

11-11

Granterra**83**

Item	Ref. No.	Qty	Description
1	7-62-01008	1	Radiator
2	8-08-00946	1	Bracket, Radiator Mounting
3	8-50-05053	2	Isolator, Radiator Mount
4	8-72-00020	1	Shroud, Radiator
5	8-72-00019	1	Shroud, Oil Cooler
6	2-00-03702	4	Washer, .625 x .281 x .063
7	2-00-00501	4	Washer, .25 ID x .44 OD x .046
8	2-00-00594	4	Nut, 1/4-20 Hex
9	8-62-01018	1	Oil Cooler
10	7-29-00192	2	Gasket, Oil Cooler
11	8-13-07088	2	Clip
12	2-00-00518	4	Lock Washer, 1/4" Helical Spring
13	2-00-00246	2	Bolt, 1/4-20 x 2.25 Hex Head
14	2-00-00220	2	Screw, 1/4-20 x .625 HHC
15	2-00-05956	1	Plug, Radiator Outlet
16	8-33-02367	1	Hose, Upper Radiator
17	7-33-02615	1	Hose, Lower Radiator
18	2-00-03404	4	Clamp
19	2-00-05261	4	Insert, 1/4-20 Threaded
20	7-07-02002	1	Overflow Bottle Assy. (1 liter)
21	2-00-00219	4	Bolt, 1/4-20 Fin. Hex Head
22	2-00-05985	1	Cap, 3/8 ID x 1 Inside Length (Rubber)
23	2-00-05363	3	Clamp, Hose
24	7-33-02724	1	Hose, 1/4" ID x 28" long (Clear)
25	7-33-02643	1	Hose, 1/4" ID x 36" long (Black)
26	2-00-04970	2	Fitting, Str. -8 ORS x -8 SAE
27	56382616	1	Clamp Constant Tension

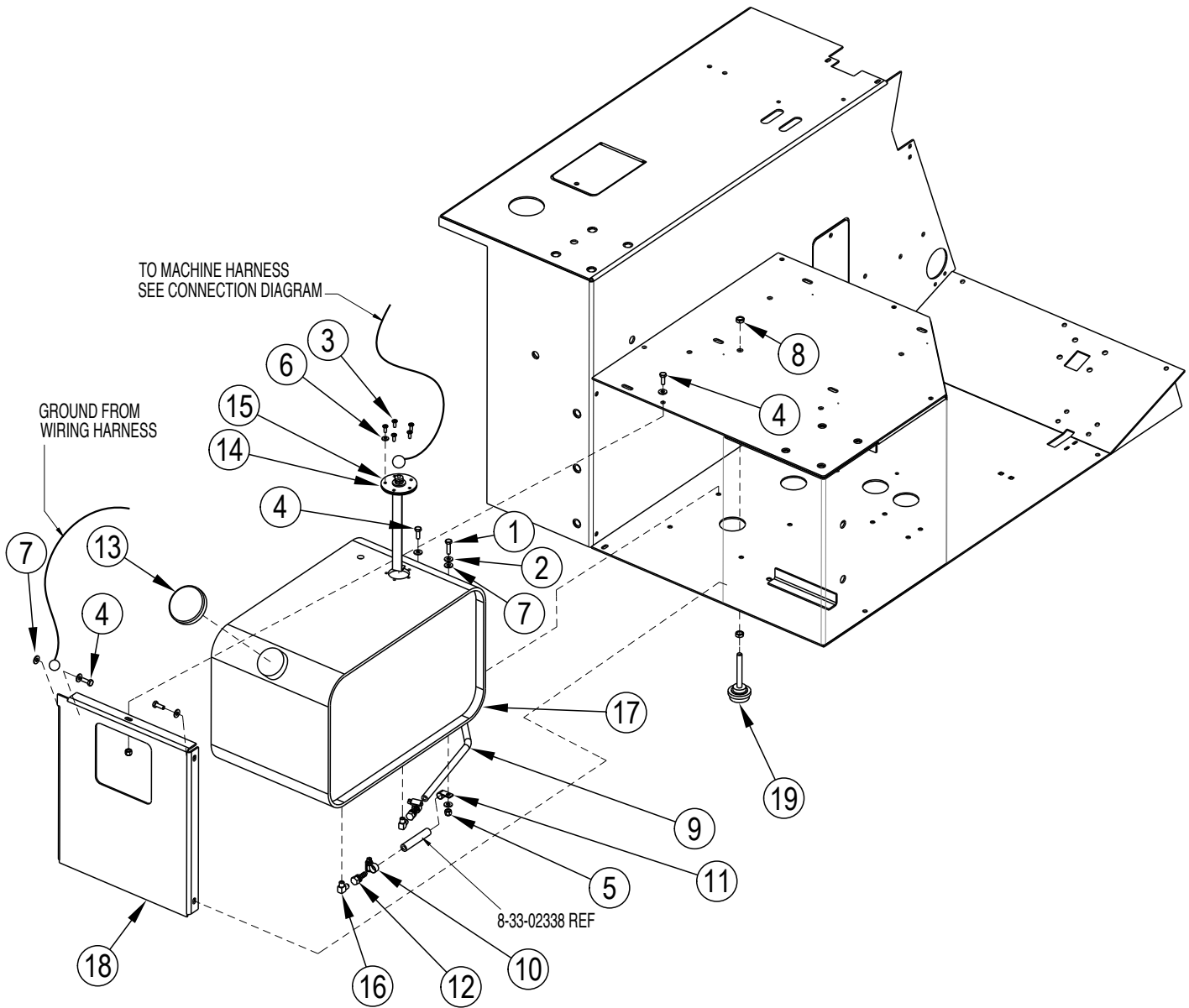

09-5	FUEL TANK [DIESEL]		
12-11	Granterra		85

Item	Ref. No.	Qty	Description
1	56002093	1	Scr, Hex 1/4-20 x 1.00
2	56002098	5	Wsh, Fit SAE 1/4
3	56002147	5	Scr, Pan Phil 10-32 x .50
4	56002155	4	Scr, Hex 1/4-20 x .75
5	56002708	2	Nut, Hex Nyl Loc 1/4-20
6	56009011	1	Wsh, Int Shprf #10
7	56009064	3	Wsh, Int Shprf 1/4
8	56009085	2	Nut-Hex Jam 3/8-16
9	8-33-02338	1	Hose - Fuel To Pump
10	56756364	2	Clamp, Hose SAE #4
11	2-00-04602	1	Clamp
12	2-00-04618	2	Fitting
13	7-11-00029	1	Cap Fuel Tank
14	7-29-00348	1	Gasket, Sending Unit
15	8-26-04003	1	Float/Sender
16	8-56-05021	2	Fitting
17	8-83-04029	1	Tank, Gas
18	56516835	1	Rear Wall - Seat Compartment
19	7-50-05144	1	Pad

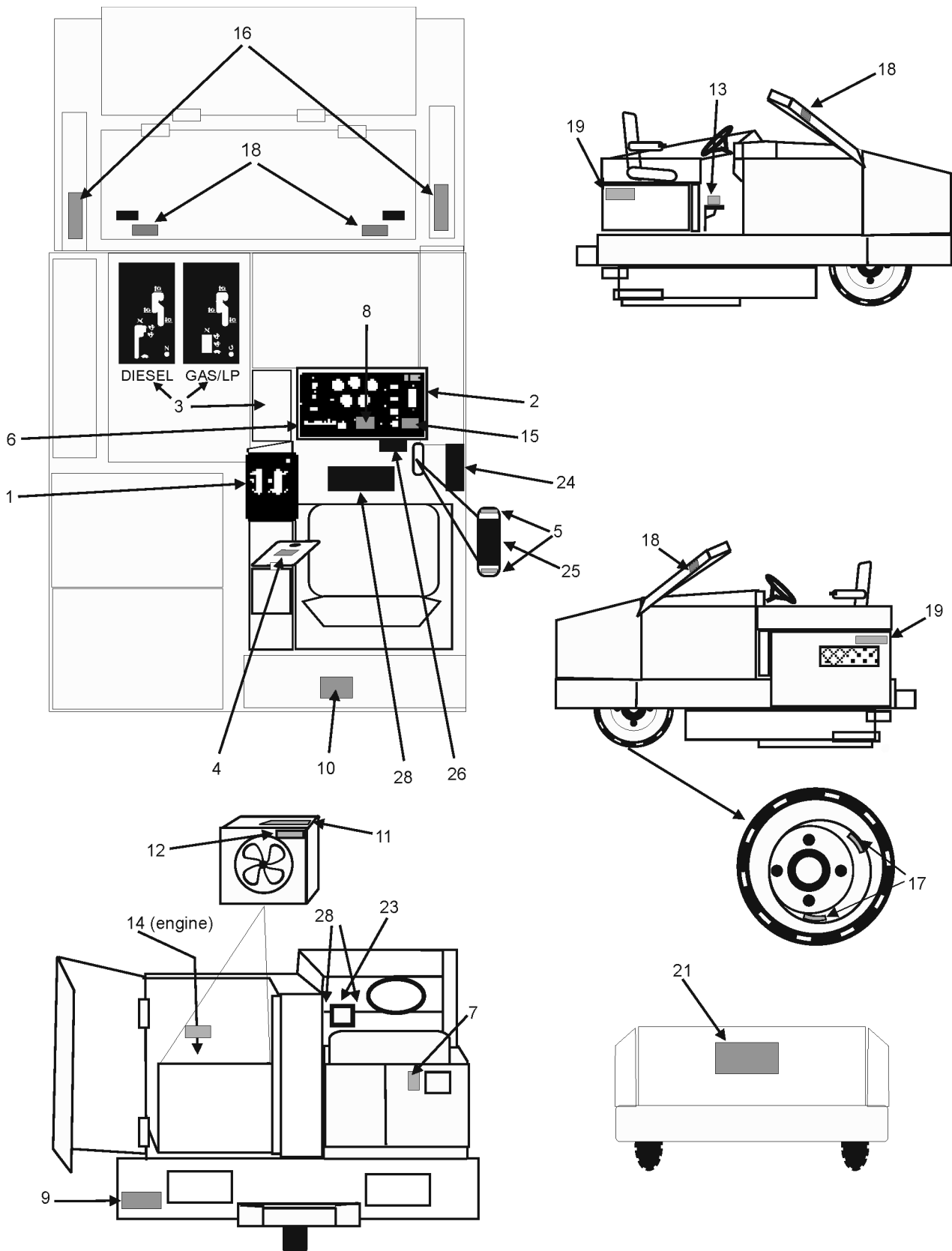

09-5	DECALS		
10-11	Granterra		87

Item	Ref. No.	Qty	Description
1	8-18-00518	1	Hopper Controls
2	8-18-00512	1	Instrument Panel
3	8-18-00519	1	Main Broom & Throttle (Diesel only)
	8-18-00555	1	Main Broom & Throttle (Gas/LPG only)
4	REF	1	Hydraulic Fluid Only
5	8-18-00490	1	Bi-directional Pedal (horizontal)
6	8-18-00487	1	Blank Squares - Option Cover
7<	REF	1	Gasoline Only
	56109404	1	Decal, Low Sulfur Diesel (Diesel Only)
8<	REF	1	Do Not Use With Flammables
9<	REF	1	Exhaust Warning
10<	REF	1	Fire Hazard
11<	REF	1	Moving Belts - Stay Clear
12<	REF	1	Moving Fan Blade-Stay Clear
13<	REF	1	Patent/Patent Pending
14<	REF	1	Surface Hot - Stay Clear
15<	REF	1	Turn Off - Lock Wheel
16<	REF	2	Put Hopper in Forward Dump Position
17<	REF	3	Split rim (Pneumatic Tire)
18<	REF	4	Pinch Point - Stay Clear
19	56516907	2	DECAL-Granterra
21	56016730	1	Decal-Advance
23	REF	1	Serial Number Plate
24	7-50-05136	1	Non-Skid, Frame Edge
25	8-50-05055	1	Non-Skid, Forward/Reverse Pedal
26	8-50-05050	1	Non-Skid, Brake Pedal
27	8-50-05052	1	Non-Skid, Drive Compartment Floor
28	2-00-04115	2	Pop Rivet
[<]	0760-871	1	Decal Kit-Warning (English Text and No-text warning decals)

[] = Not Shown

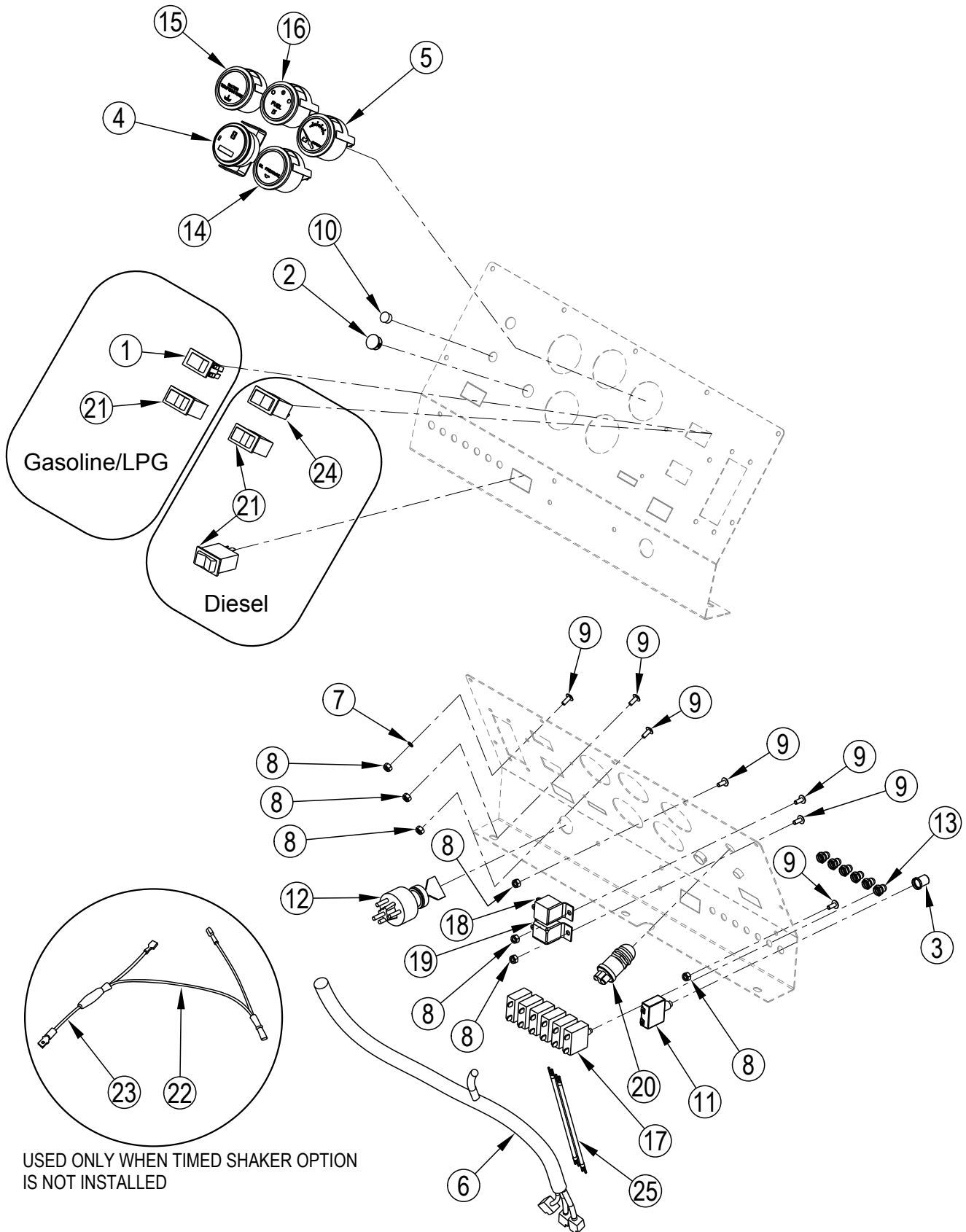

USED ONLY WHEN TIMED SHAKER OPTION IS NOT INSTALLED

09-5	INSTRUMENT PANEL		
13-8	Granterra		89

Item	Ref. No.	Qty	Description
1#	56381824	1	Switch Rocker Dpdt On-On
2#	56383153	1	Plug-Cap .687 Dia
3#	56459369	1	Boot, Reset Button
4#	56478363	1	Meter-Hour
5#	56482044	1	Meter Volt
6#	0895-132	1	Instrument Panel Harness
7#	2-00-00512	1	Washer, Star
8#	2-00-01246	7	Nut-#10-24 Elastic Stop Nut
9#	2-00-03061	7	Screw, #10-24 X .5 Truss Head
10#	2-00-04942	1	Plug .50 Dia (Light Switch)
11#	7-64-00025	1	Circuit Breaker- 25 Amp
12#	7-82-00026	1	Switch, Key - Anti Re-Start (Key only: 2-60-02272)
13#	8-11-00044	6	Boot (Circuit Breaker)
14#	8-48-05027	1	Gauge, Oil Pressure
15#	8-48-05028	1	Gauge, Water Temperature
16#	8-48-05032	1	Gauge, Fuel (Gas & Diesel only)
#	7-11-04035	1	Kit, Low LP Indicator Light (LP only)
17#	8-64-00008	6	Circuit Breaker- 15 Amp
18#	8-64-00012	1	Relay-Shaker Motor
19#	8-64-05009	1	Relay-12 Vdc
20#	8-82-00024	1	Horn, Push Button
21#	8-82-00062	1	Switch-Rocker (SPST) (qty of 2 on Diesel)
22#	8-90-07361	1	Wire Td-1 6 to 7 to M286 to M4
23#	8-90-07385	1	Wire Jumper
24#	56381824	1	Switch Rocker DPDT On-On (Diesel)
25#	8-90-07357	2	Wire WT Gage to Fuel Gage (Gas & Diesel only)

= Revised or new since last update

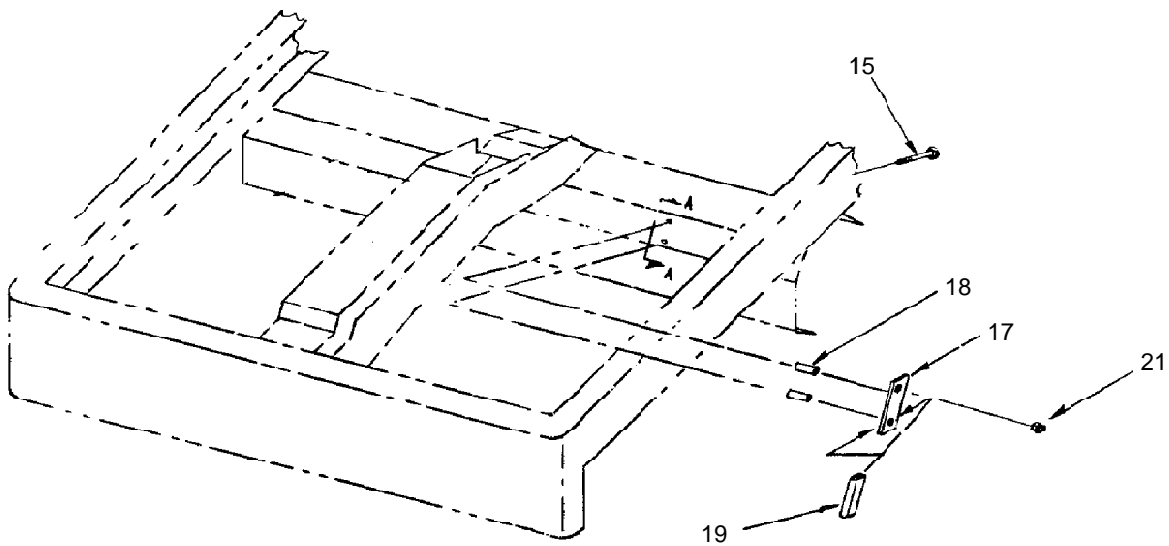
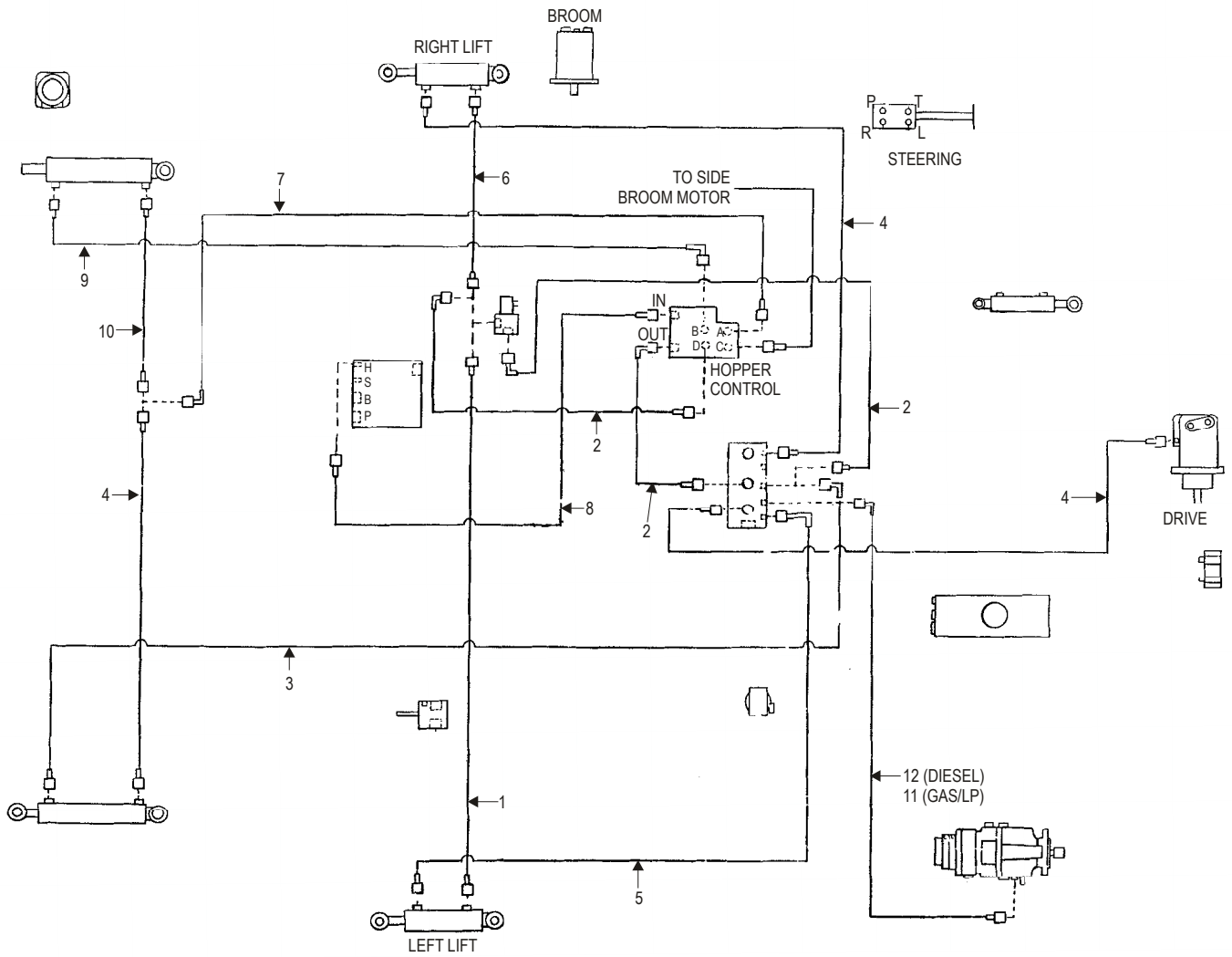

09-5	HYDRAULIC HOSE SYSTEM		
09-10	Granterra		91

Item	Ref. No.	Qty	Description
1*	8-33-02184	1	Hose, #4 x 50.5" -0-0-ORS-1WB
2*	7-33-02225	3	Hose, #4 x 38.0" -0-90-ORS-1WB
3*	8-33-02198	1	Hose, #4 x 107.0" -0-90-ORS-1WB
4*	8-33-02185	3	Hose, #4 x 56.0" -0-0-ORS-1WB
5*	7-33-02193	1	Hose, #4 x 49.0" -0-90-ORS-1WB
6*	8-33-02217	1	Hose, #4 x 32.0" -0-0-ORS-1WB
7*	8-33-02174	1	Hose, #4 x 16.5" -0-90-ORS-1WB
8	8-33-02178	REF	Hose, #4 x 15.0" -0-0-ORS-1WB
9*	8-33-02204	1	Hose, #4 x 76.0" -0-90-ORS-1WB
10*	8-33-02179	1	Hose, #4 x 46.0" -0-0-ORS-1WB
11	8-33-02329	1	Hose, #4 x 30.0" -0-0-90-ORS-1WB (Gasoline/LPG Only)
12	7-33-02225	1	Hose, #4 x 38.0" -0-90-ORS-1WB (Diesel Only)
15	2-00-00198	2	Bolt, 1/4-20 x 2.00 Carriage
17	8-65-00024	1	Clamp, Hydraulic Hose
18	7-75-01063	2	Spacer, .375 x .277 x 1.20
19	8-08-07045	2	Edging
21	2-00-00641	2	Nut, 1/4-20 Hex Fiber

*Part of Hose Kit 0860-753

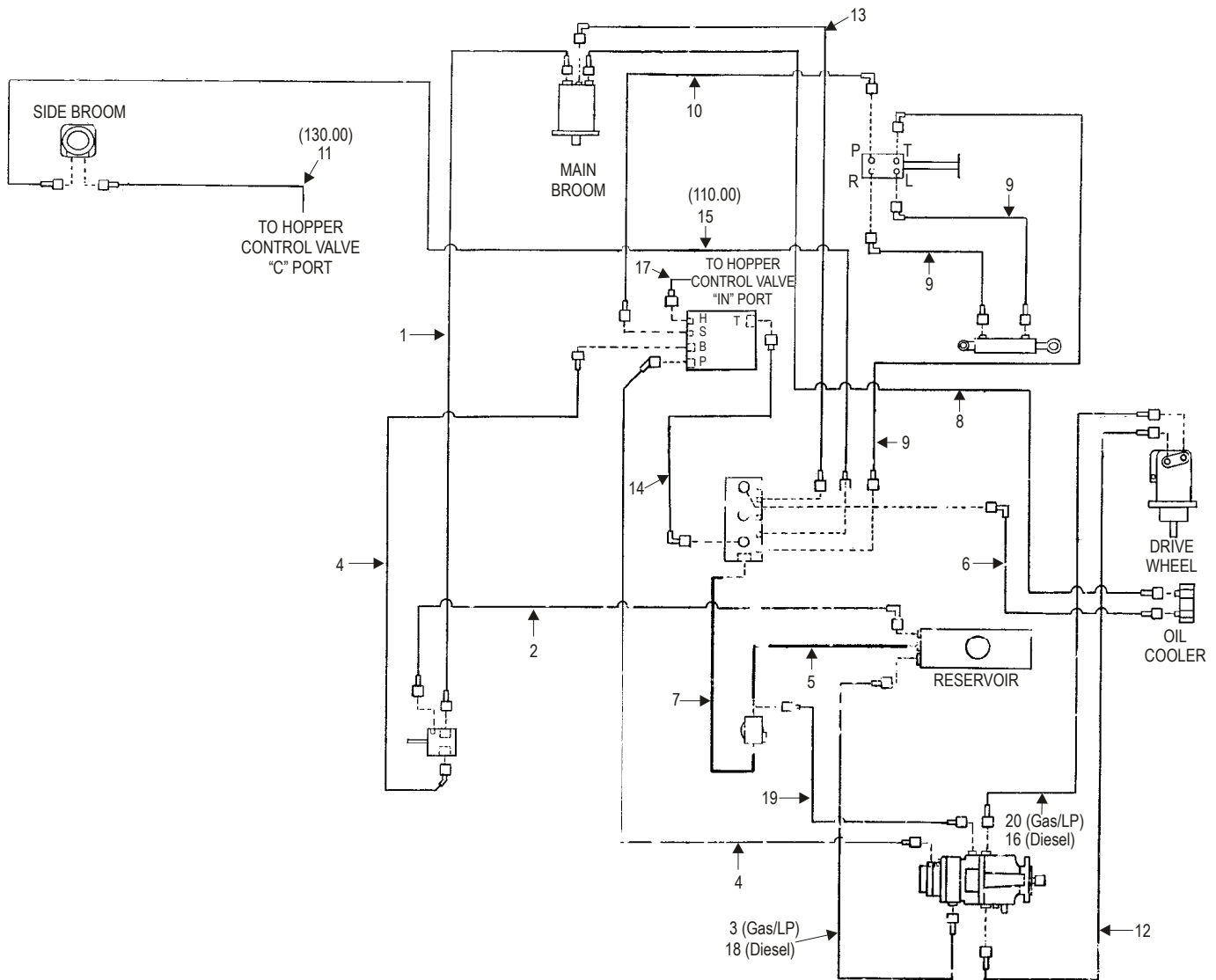

Item	Ref. No.	Qty	Description
1*<	8-33-02267	2	Hose, #8 x 62.0" -0-0-ORS-2WB
2*<	7-33-02189	1	Hose, #4 x 26.0" -0-90-ORS-1WB
3*	8-33-02215	1	Hose, #12 x 36.0" -0-0-ORS-1WB
4*<	8-33-02265	2	Hose, #8 x 23.0" -0-45-ORS-2WB
5	8-33-02273	1	Hose, 1 x 15.0" Return
6*<	8-33-02418	1	Hose, #8 x 52.0" -0-90-ORS-1WB
7	7-33-02317	1	Hose, 1 x 15.0" Return
8*<	7-33-02553	1	Hose, #8 x 90.0" -0-0-ORS-2WB
9*<	7-33-02190	3	Hose #4 x 67.0" -0-90-ORS-1WB
10*<	7-33-02200	1	Hose, #4 x 56.0" -0-90-ORS-1WB
11*<	8-33-02278	1	Hose, #4 x 130.0" -0-0-ORS-1WB
12*<	8-33-02195	1	Hose, #8 x 69.5" -0-0-ORS-2WB
13*<	7-33-02193	1	Hose, #4 x 49.0" -0-90-ORS-1WB
14*<	7-33-02206	1	Hose, #8 x 14.25" -0-90-ORS-1WB
15*<	8-33-02277	1	Hose, #4 x 110.0" -0-0-ORS-1WB
16<	8-33-02191	1	Hose, #8 x 56.5" -0-0-ORS-2 WB
17*<	8-33-02178	1	Hose, #4 x 15.0" -0-0-ORS-1WB
18<	8-33-02194	1	Hose, #12 x 32.0" -0-0-ORS-1WB
19*<	8-33-02217	1	Hose, #4 x 32.0" -0-0-ORS-1WB
20*	8-33-02196	1	Hose, #8 x 75.5" -0-0-ORS-2WB

*PART OF HOSE KIT 0860-755 (GAS/LP MODELS)

<PART OF HOSE KIT 0860-756 (DIESEL MODELS)

09-5

HARNESS ROUTING - GAS/LP/DIESEL

09-10

Granterra**95**

Item	Ref. No.	Qty	Description
1	0895-131	1	Machine Harness
2	8-09-01081	2	Bushing, Snap
3	7-13-07096	17	Clamp, Adjustable
4	2-00-04345	5	Ty-Rap
5	2-00-00594	1	Nut, 1/4-20 Hex
6	2-00-00641	1	Nut, 1/4-20 Fiber Lock
7	2-00-00503	2	Washer, 1/4 Int. - Ext.
8	2-00-00205	1	Screw, 1/4-20 x 1.0 HHC
9	2-00-04937	1	Cable Tie
10	2-00-03063	1	Screw, 10-24 x 3/4 THM
11	2-00-00585	1	Nut, Hex 5/16-18 x .500 x .265
12	2-00-00519	1	Lock Washer, #10 Helical Spring
13	2-00-00605	1	Nut, #10-24 x .375 x .125 Hex
14	2-00-01246	1	Nut, #10-24 Fiber Lock
15	8-32-09013	1	Horn
16	2-00-00208	1	Screw, 5/16-18 x 3/4 HHC
17	2-00-02303	2	Lock Washer, 5/16
[]	7-90-07262	1	Battery Cable Negative
[]	8-90-07457	1	Battery Cable Positive (Gasoline/LPG only)
[]	8-90-07211	1	Battery Cable Positive (Diesel only)
[]	2-00-05171	1	Boot Positive
[]	2-00-05173	1	Battery Insulator
[]	0875-008	1	Battery Wet 12V (Maint. Free) (Gasoline/LPG only)
[]	0875-057	1	Battery Wet 12V (Maint. Free) (Diesel only)

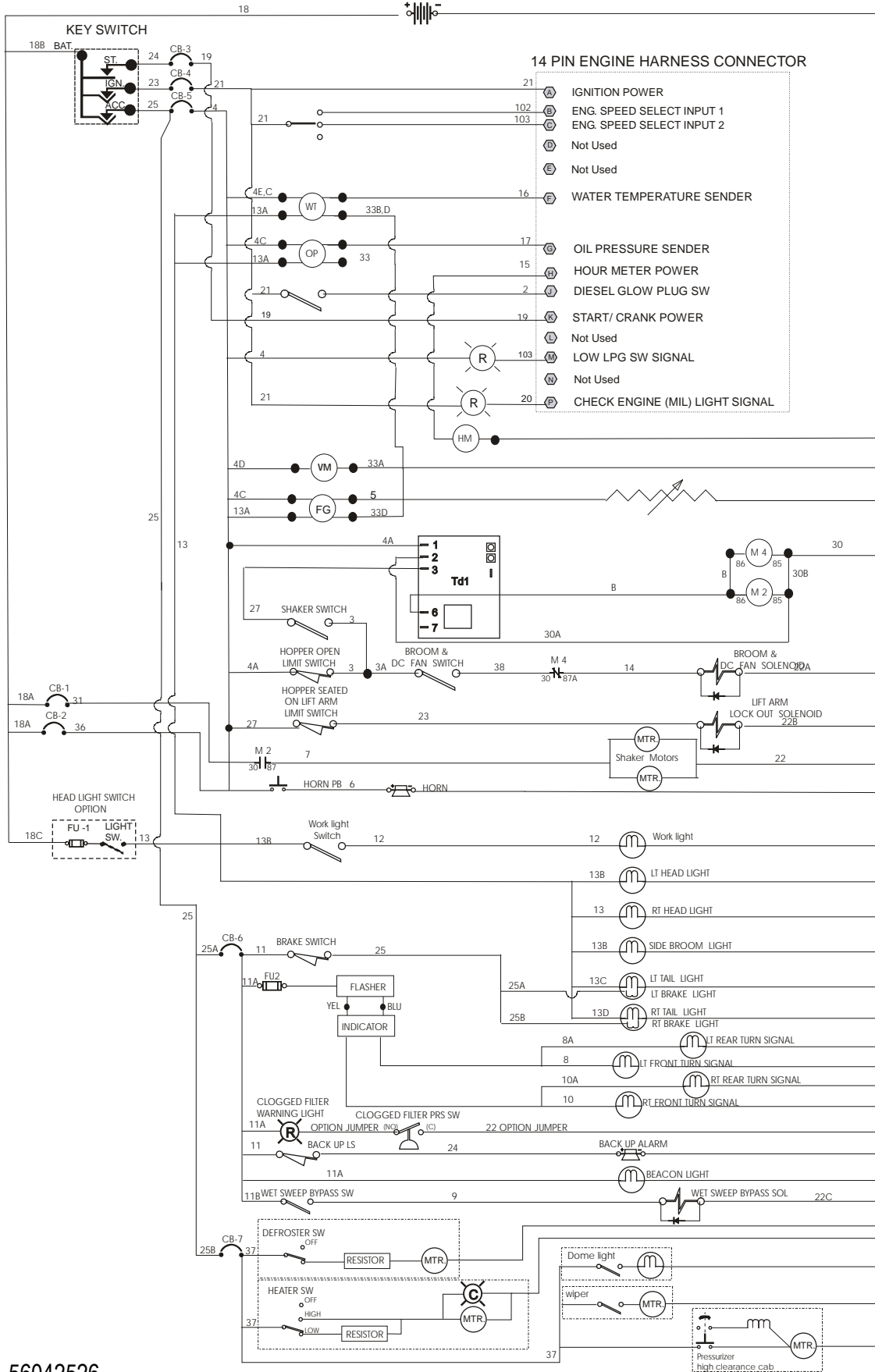

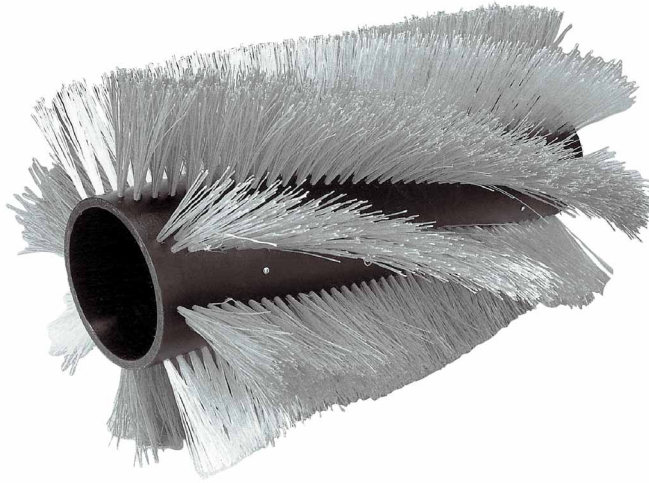
**Main Broom:****PN8-08-03202 Proex & Wire (STD.) (8 Double Rows)**

This broom has a more aggressive cleaning action, used to pick up heavier debris.

PN8-08-03207 Nylon (Optional) (8 Double Rows)

General purpose broom that can be used for all types of light soil. High wear material so uneven surfaces do not cause excessive wear. Nylon has a high heat deflection temperature, is chemical resistant and will absorb water in wet conditions. Truly a general purpose broom.

PN8-08-03204 Proex (Optional) (8 Double Rows)

Synthetic fiber made of polypropylene designed to pick up paper, gravel, sand and other lighter less bulky litter.

PN8-08-03210 High Density Fibre/Wire (Optional)

Fiber and wire bristles offer dust control from the natural vegetable fibers and a light cutting action from the crinkle wire. Designed for applications with fine dust and light compacted soilage.

PN8-08-03214 Polypropylene & Wire (Optional) (8 Double Row)**PN8-08-03209 Polypropylene (Optional) (8 Double Row)****8 Double Row**

Length.....**50" (127 cm)**

Diameter.....**16" (40.6 cm)**

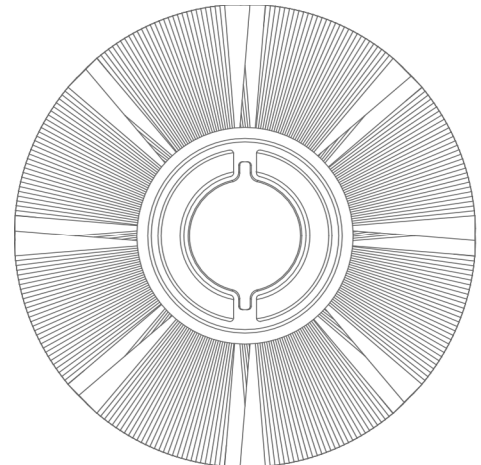
**Side Broom:****PN8-08-03211 Nylon (STD)**

The side broom function is to sweep the dirt and debris away from the curb, wall, pallet, etc. into the path of the main broom.

PN8-08-03212 Polypropylene (Optional)**PN0880-439 Wire Side Broom (Optional / broom and hardware)**

Diameter.....**21" (53.34 cm)**



Nilfisk-Advance Equipamentos de Limpeza Ltda.
Av. Dep. Emílio Carlos, 2.499 - Bairro do Limão - 02721-200
São Paulo - SP - Brasil
www.nilfisk-advance.ind.br
www.plataforma.ind.br
Tel.: (11) 3959-0300
Fax: (11) 3959-0306
©2013 Nilfisk-Advance, Inc.



14600 21st Avenue North
Plymouth, MN 55447-3408
www.advance-us.com
Phone: 800-989-2235
Fax: 800-989-6566
©2013 Nilfisk-Advance, Inc.

A Nilfisk-Advance Brand