

SC350

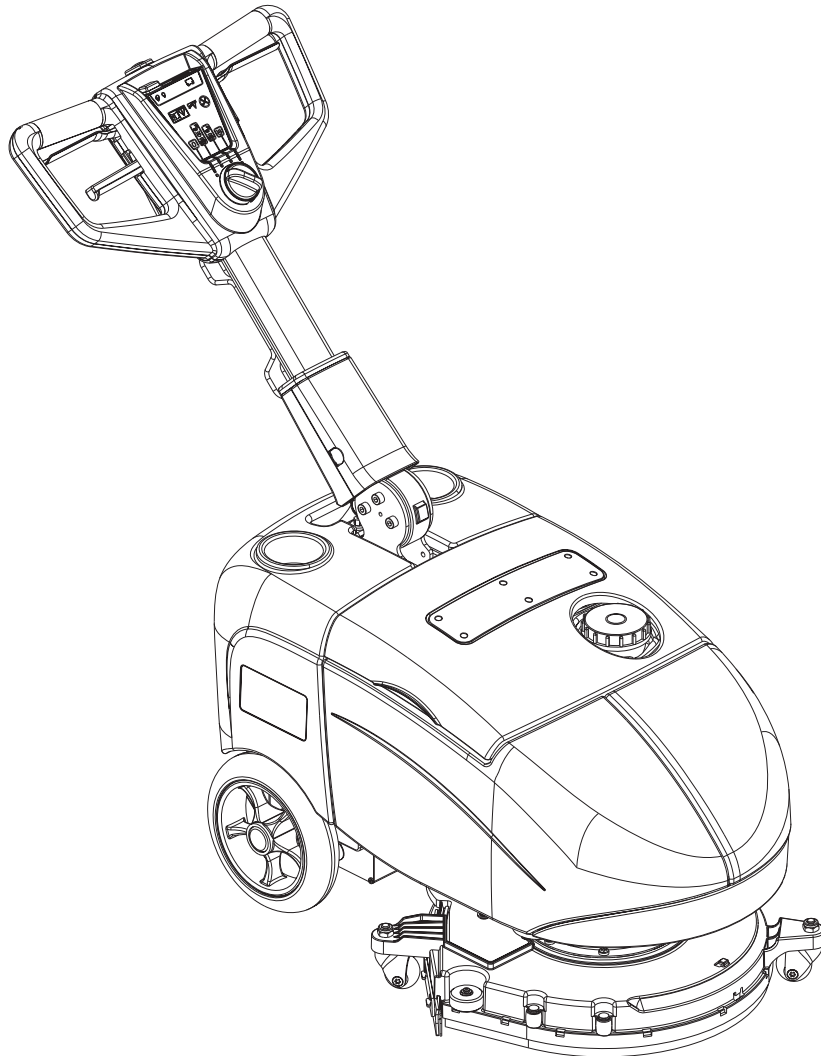

PARTS LIST

Advance models: 9087304020



Advance

9099123000(1)2011-01

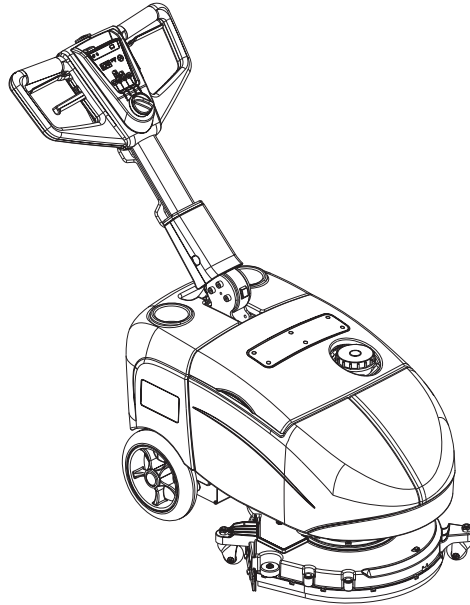

DESCRIPTION

PLAN

GENERAL VIEW	2 - 3
COVER AND TANKS	4 - 5
FRAME	6 - 7
HANDLE SUPPORT	8 - 9
HANDLE BAR	10 - 11
BRUSH DECK	12 - 15
ELECTRICAL DIAGRAM	16 - 17
RECOMMENDED SPARE PARTS	18

WHEN ORDERING PARTS

- * Use the 8, 9 or 10 digit numbers from the "Ref. No." columns in this parts list.
- * Specify the model and serial number of the machine.
- * Use the space below to record the model and serial number for future reference.

Model _____ Serial No. _____

*** = *Optional***

= *Modified item No. or New item No.*

[] = *Not shown*

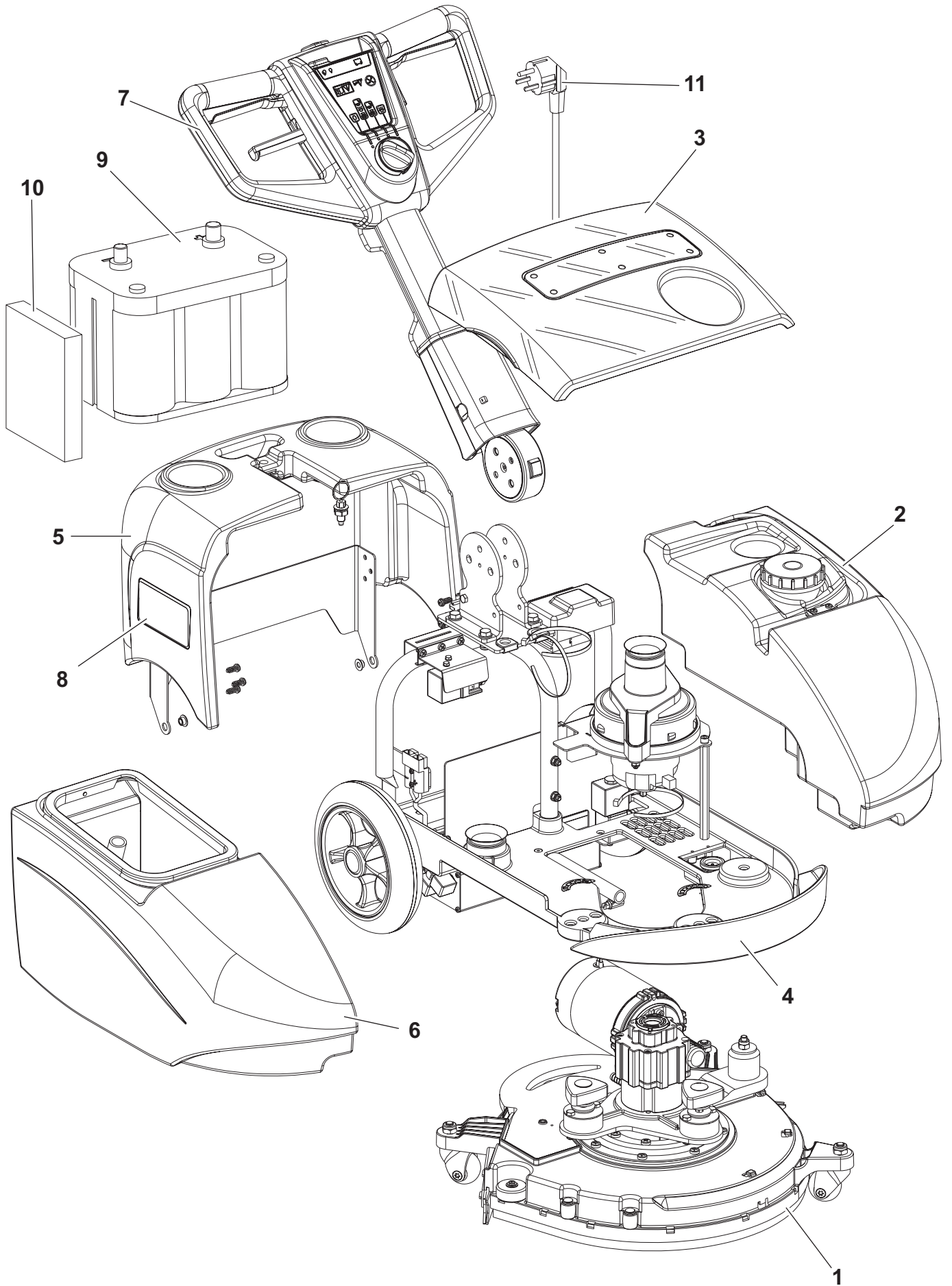

2011-01

GENERAL VIEW

SC350

3

Kit	Item No.	Ref. No.	Qty	Description
	1		1	DECK
	2		1	SOLUTION TANK
	3		1	COVER TANK
	4		1	FRAME
	5		1	BATTERY COVER
	6		1	RECOVERY TANK
	7		1	HANDLE
	8	9099128000	1	LABELS KIT SC350 ADVANCE
	9	1464484000	1	BATTERY 12V 87AhC5 AGM
	10	9098934000	1	PANEL BATTERY 30X170X110MM
	11	9096914000	1	CABLE EXTENSION US

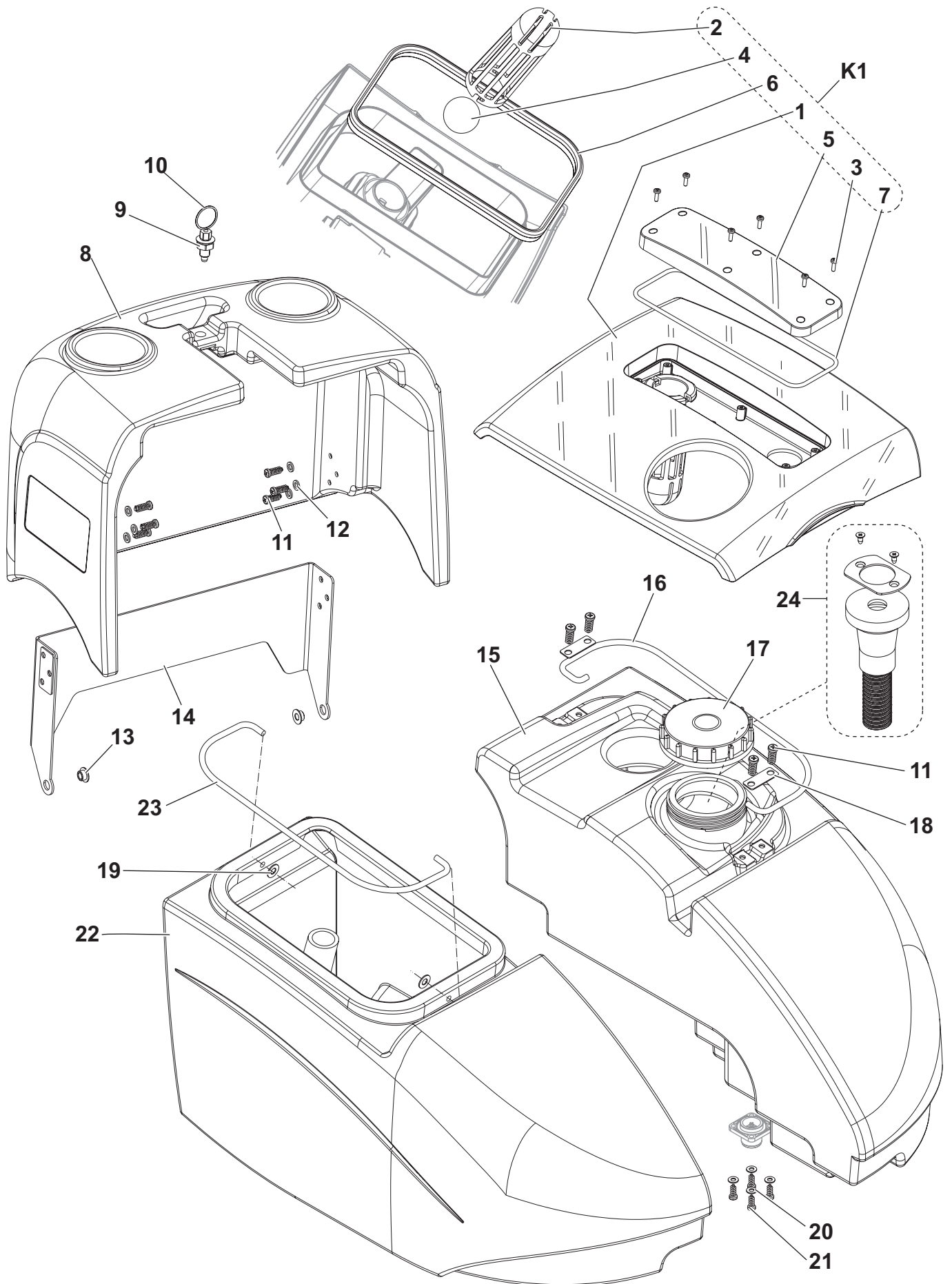

2011-01

COVER AND TANKS

SC350

5

Kit	Item No.	Ref. No.	Qty	Description
K1	1		1	COVER TANK
K1	2		1	CAGE FLOAT
K1-K2	3		6	SCREW 3.5X10 THD FORMING
K1	4		1	BALL FLOATING
K1	5		1	CAP TANK COVER
K1	6	9099127000	1	GASKET TANK COVER KIT
K1	7		1	GASKET MOUSSE D.4MM
	8	9098318000	1	BATTERY COVER
	9	145 1147 000	1	WASHER 10,2X18,8X0,35
	10	146 2449 000	1	PLUNGER INDEXING
K2	11		10	SCREW CYL HD 5X16 SELF L.
K2	12		6	WASHER
K2	13		2	BUSH
	14	9098309000	1	SUPPORT BATTERY COVER
	15	9098149000	1	TANK SOLUTION RAL 7001
	16	9098776000	1	HANDLE DETERGENT TANK
	17	9098705000	1	CAP THREADED
	18	9098621000	2	PLATE HANDLE TANK
	19	9098473000	2	COVER PIN
K2	20		4	WASHER M4 UNI6592
K2	21		4	SCREW 3.5X12
	22	9098148000	1	TANK RECOVERY RAL 7001
	23	9098391000	1	HANDLE RECOVERY TANK
	24*	9099011000	1	HOSE FILLING KIT
	K1	9098989000	1	COVER KIT
	[K2]	9098990000	1	HARDWARE COVER AND TANKS KIT

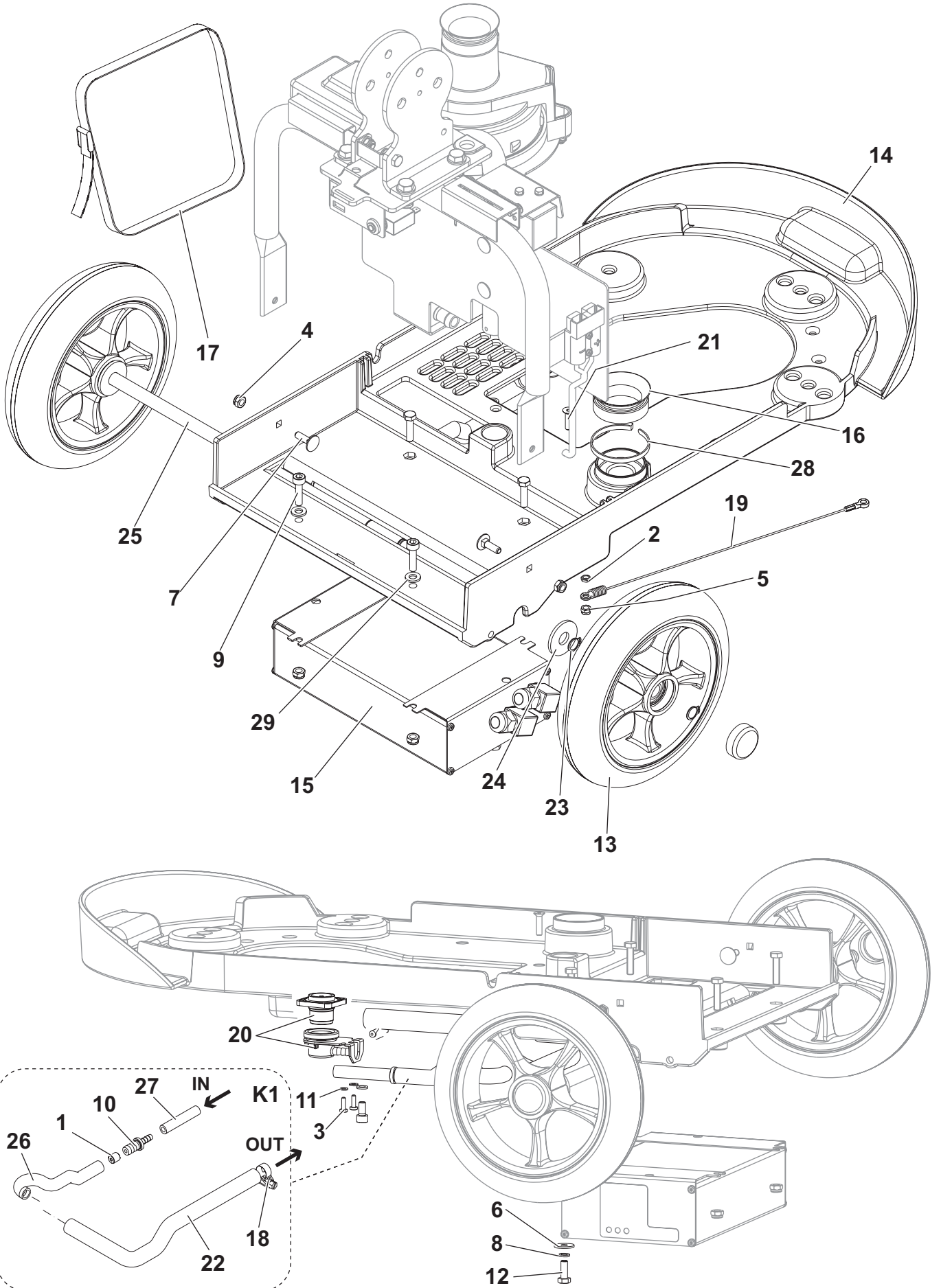

2011-01	FRAME			
	SC350			7

Kit	Item No.	Ref. No.	Qty	Description
K1	1		1	REDUCTION WATER
K2	2		1	NUT, HEX THIN M5 SS
K2	3		2	SCREW 3.5X10 THD FORMING
K2	4		7	NUT SELF L. M6 UNI7474 SS
K2	5		5	NUT SELFLOCKING LOW M5 UN
K2	6		2	WASHER 6X18 UNI6592
K2	7		2	SCREW M6X20 UNI5731
K2	8		3	WASHER
K2	9		4	SCREW M5X20 UNI5931 SS
K1	10		1	FITTING
K2	11		2	WASHER
K2	12		2	SCREW
	13	9098237000	2	WHEEL D.200MM
	14	9098144000	1	CHASSIS
	15	9098188000	1	CHARGER BATTERY 12V 12A (CH)
	16	9098319000	1	GASKET
	17	146 3054 000	1	BELT BATTERY FIXING
K1	18		1	CLAMP
	19	9099042000	1	CABLE DECK
	20	9098697000	1	VALVE WATER COMPLETE
K2	21		1	SCREW
K1	22		1	HOSE D.12 L=500 MM
K2	23		4	RING D 12 UNI7435
K2	24		2	WASHER 12.5X34X3 NYLON
	25	9098310000	1	PIN WHEEL
K1	26		1	HOSE D. 12
K1	27		1	PIPE 6X11
K2	28		1	CLAMP 290X4.8
K2	29		4	WASHER 5X15 UNI6593 SS
	K1	9098992000	1	PIPES KIT
	[K2]	9098993000	1	HARDWARE FRAME KIT

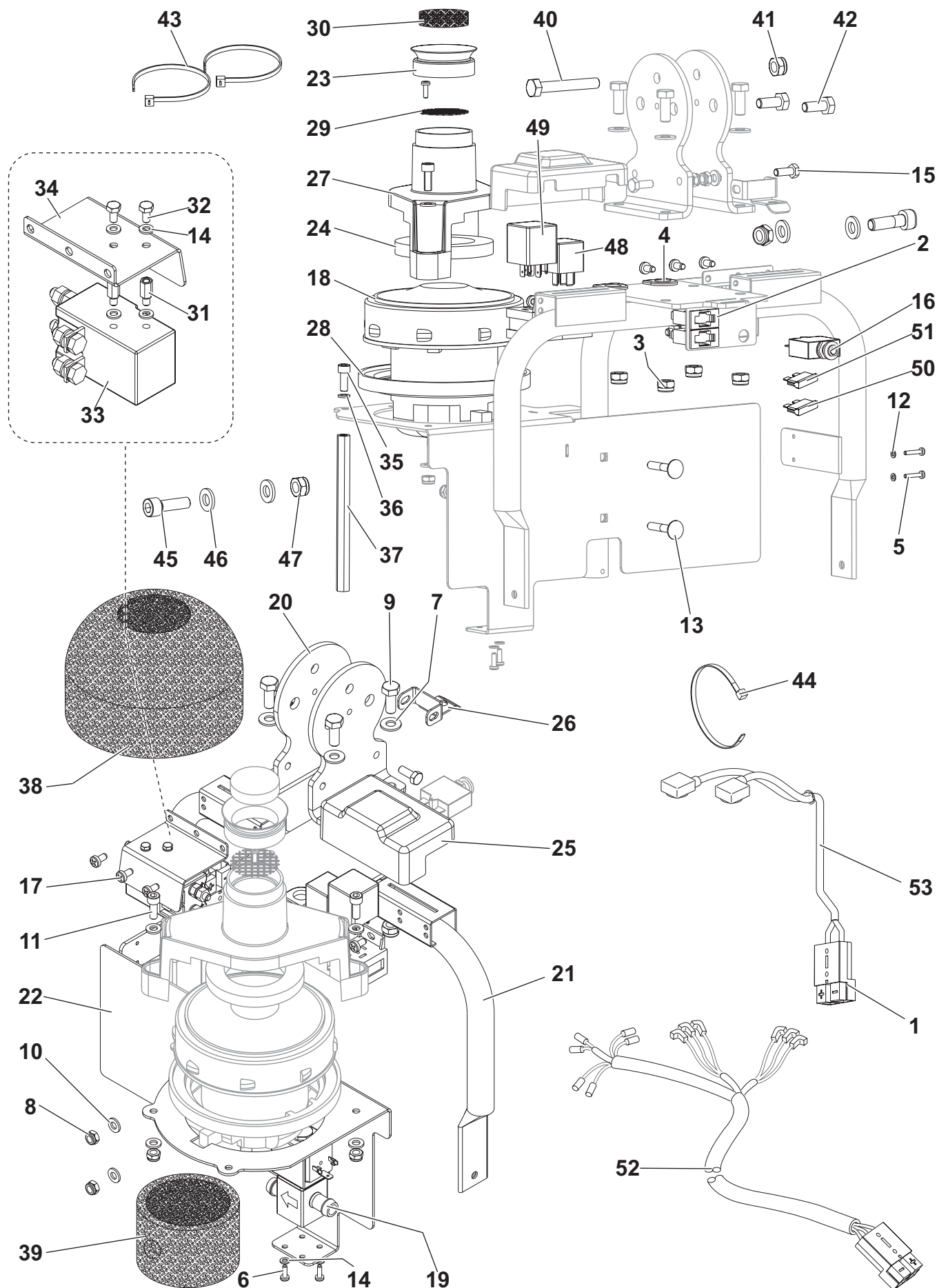

Kit	Item No.	Ref. No.	Qty	Description
	1	9098760000	2	CONNECTOR 50A GREY
	2	9098924000	2	FUSE HOLDER
K1	3		4	NUT SELFLOCKING LOW M8 UN
	4	909 6542 000	2	GROMMET
K1	5		2	SCREW M3X16 UNI7687
K1	6		3	SCREW 3.5X10 THD FORMING
K1	7		4	WASHER M8 UNI6592 SS
K1	8		6	NUT SELF L. M6 UNI7474 SS
K1	9		4	SCREW M8X20 UNI5739 SS
K1	10		8	WASHER M6 UNI6592 SS
K1	11		2	SCREW
K1	12		2	WASHER
K1	13		2	SCREW
K1	14		6	WASHER
K1	15		2	SCREW
	16	909 5706 000	1	BREAKER CIRCUIT 30A (F1)
K1	17		5	SCREW M5X10 DIN7500
	18	9098111000	1	MOTOR VACUUM 12V 200W (M2)
	19	9098112000	1	SOLENOID VALVE 12V (EV)
	20	9098185000	2	BRACKET HANDLE
	21	9098267000	1	SUPPORT HANDLE
	22	9098268000	1	SUPPORT VACUUM MOTOR
	23	9098319000	1	GASKET
	24	9098327000	1	GASKET VACUUM MOTOR
	25	9098365000	1	COVER RELAY
	26	9098482000	1	BRACKET PLUNGER BLOCK
	27	9098483000	1	COVER VACUUM MOTOR
	28	9098554000	1	GASKET VACUUM MOTOR
	29	9098654000	1	PROTECTION
	30	9098655000	1	FILTER VACUUM MOTOR
K1	31		2	SPACER M4 L10
K1	32		2	SCREW M4X 8 UNI5739 SS
	33	9098424000	1	SWITCH ELECTROMAGNETIC 12V 70A (ES1)
	34	9098560000	1	PLATE SUPPORT ELECTR.SWITCH
K1	35		2	SCREW M6X12 UNI5931 SS
K1	36		3	WASHER
	37	9098559000	1	SPACER SUPPORT VACUUM MOTOR
	38	9098656000	1	CASING VACUUM MOTOR
	39	9098925000	1	CASING LOWER VACUUM MOTOR
K1	40		1	SCREW M8X55 UNI5739
K1	41		1	NUT SELFLOCKING LOW M8 UN
K1	42		2	SCREW M10X25 UNI5739 SS
K1	43		2	CLAMP
K1	44		4	CLAMP
K1	45		2	SCREW SOCKET HD M6X16 SS
K1	46		4	WASHER M6 UNI6592 SS
K1	47		2	NUT SELF L. M6 UNI7474 SS
	48	9098441000	1	RELAY 12V (ES2)
	49	9098375000	1	TIMER CYCLICAL (T1)
	50	145 8513 000	1	FUSE BLADE 30A UL (F2)
	51	145 9852 000	1	FUSE 5A (F3)
	52	9098387000	1	HARNESS MACHINE
	53	9098849000	1	HARNESS BATTERY
[K1]		9098994000	1	HARDWARE HANDLE BAR SUPP. KIT

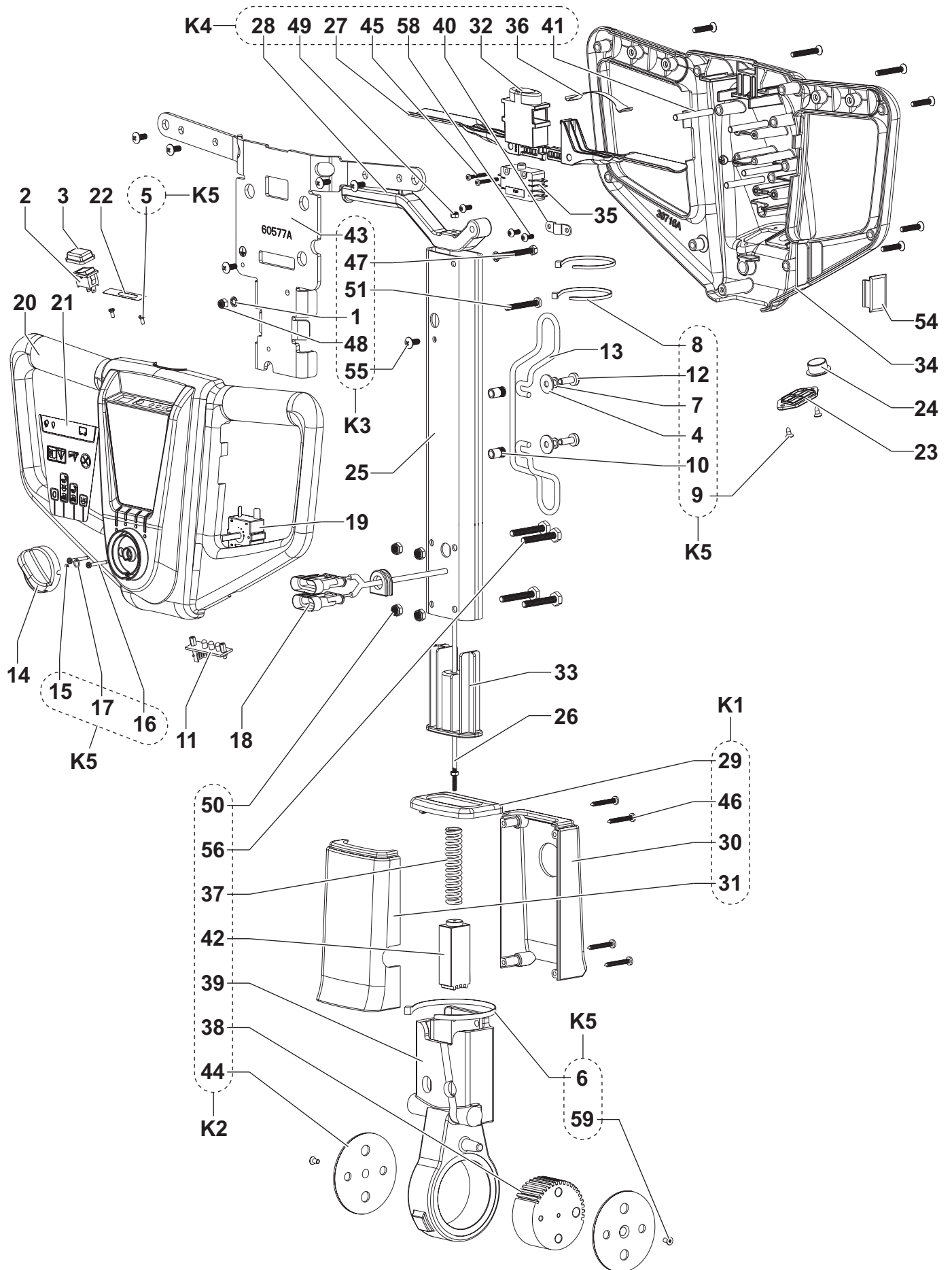

Kit	Item No.	Ref. No.	Qty	Description
K3	1		3	WASHER
	2	L08603153	1	SWITCH PUMP (SW3)
	3	L08603154	1	CAP PROTECTION
K5	4		2	WASHER 6X18X1.5 UNI6593
K5	5		2	SCREW M3X8 UNI7688
K5	6		1	CLAMP 290X4.8
K5	7		2	WASHER
K5	8		2	CLAMP
K5	9		2	SCREW 3.9X9.5 UNI6955
K5	10		2	INSERT M6X15 UNI9203
	11	146 3073 000	1	BOARD. LED (EB1)
K5	12		2	SCREW M6X16 UNI7687 SS
	13	909 5149 000	1	SUPPORT CABLE
	14	9097283000	1	KNOB CONTROL FUNCTIONS
K5	15		1	SCREW GRUB M3X3 DIN916
K5	16		2	SCREW 2.9X25 UNI6954 THD
K5	17		1	SEAL O-RING
	18	9098386000	1	HARNES HANDLE BAR
	19	9098405000	1	SWITCH ROTATIVE 4 POSITIONS (SW1)
	20	9098530000	1	COVER HANDLE FRONT
	21	9098615000	1	DECAL CONTROL PANEL
	22	9098616000	1	DECAL BATTERY LED
	23	9098812000	1	CAP FOR HANDLE
	24	9098813000	1	CAP D.18.5/D.40MM BLACK
	25	9098835000	1	TUBE HANDLE
	26	9098836000	1	ROD INDEX
K4	27		2	LEVER SWITCH
K4	28		1	LEVER
K1	29		1	CAP RUBBER
K1	30		1	COVER REAR
K1	31		1	COVER FRONT
K4	32		1	BUTTON INTERLOCK
	33	VF47033	1	RETAINER
	34	39716A	1	REAR COVER HANDLE
	35	40263A	1	SWITCH DPDT (SW2)
K4	36		1	SPRING INTERLOCK BUTTON
K2	37		1	SPRING COMPRESSION
K2	38		1	GEAR
K2	39		1	HOUSING GEAR INDEX
K4	40		1	CLAMP CORD
K4	41		4	PIN HANDLE SUPPORT
K2	42		1	GEAR INDEX
K3	43		1	HANDLE SUPPORT
K2	44		2	PLATE, GEAR HOUSING
K4	45		2	SCREW M3X25
K1	46		4	SCREW ST4.2-1.4
K3	47		1	SCREW M5X43
K3	48		1	NUT LOCK M5 SS HEX
K4	49		1	NUT LOCK M4 SS HEX
K2	50		4	NUT LOCK M6 SS HEX
K3	51		1	SCREW M5X40 SS PAN HEAD PHILLIPS
	54	VF54041	1	HANDLE PLUG
K3	55		6	SCREW M5X12 TRUSS HEAD PHILLIPS
K2	56		4	SCREW M6 X 40 SS HEX HEAD
K4	58		3	SCREW, M4 X 10 SS PAN HEAD PHILLIPS
K5	59		2	SCREW M4X8 UNI7688
	K1	11271A	1	LOWER COVER KIT
	K2	11272A	1	BOX HOUSING GEARS KIT
	K3	11273A	1	HANDLE SUPPORT KIT
	K4	11274A	1	HANDLE SWITCH LEVER KIT
	K5	9098995000	1	HARDWARE HANDLE BAR KIT

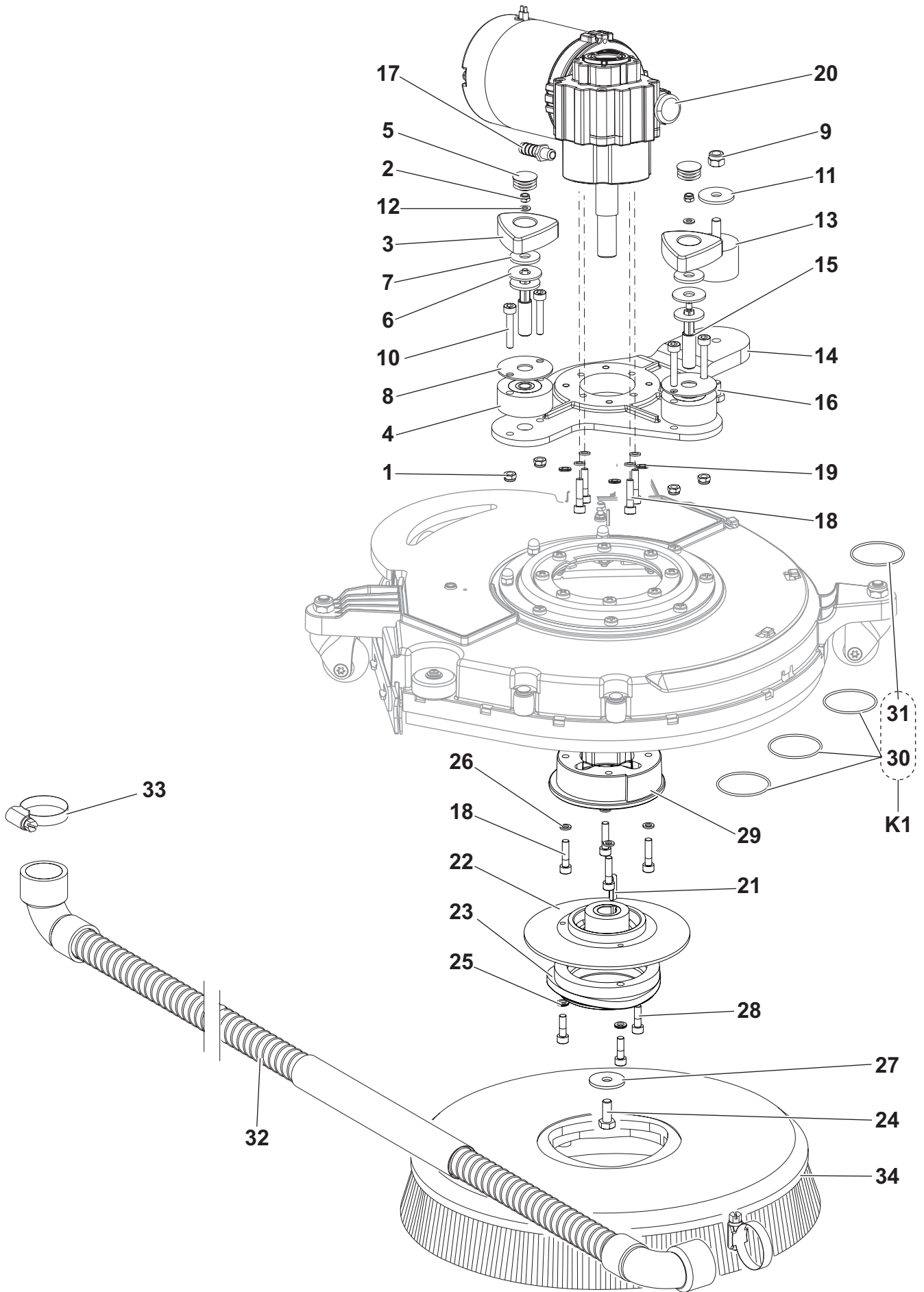

Kit	Item No.	Ref. No.	Qty	Description
K2	1		4	NUT SELF L. M6 UNI7474 SS
K2	2		2	NUT SELFLOCKING LOW M5 UN
	3	L08812203	2	KNOB
	4	L08812213	2	BUFFER
	5	L08812426	2	CAP FOR KNOB
K2	6		2	WASHER 10X30X2
K2	7		4	WASHER 9.5X27X2.5
	8	L08812779	2	PLATE.VIBRATION DAMPING
K2	9		1	NUT SELF L. M8 UNI7473
K2	10		4	SCREW M6X35 UNI5931 SS
K2	11		1	WASHER
K2	12		2	WASHER
	13	9097184000	1	VIBRATION DAMPING M8 60SH
	14	9098083000	1	SUPPORT BRUSH DECK
	15	9098557000	2	PIN BRUSH PLATE FIXING
K2	16		1	SCREW M8X12 UNI5739 SS
	17	L08601624	1	HOLDER RUBBER 1/4 D.10
K2	18		8	SCREW M6X25 UNI5931 SS
K2	19		4	WASHER
	20	9097976000	1	REDUCTION GEARMOTOR 12V (M1)
	21	145 8024 000	1	KEY 5X 5X25
	22	L08812306	1	HUB.BRUSH R.GEARMOTOR
	23	L08812480	1	HUB.BRUSH
K2	24		1	SCREW M8X20 UNI5739 SS
K2	25		3	WASHER NORD LOCK M6
K2	26		4	WASHER
K2	27		1	SCREW
K2	28		3	SCREW M6X20 UNI5931 SS
	29	9098394000	1	FLANGE BRUSH DECK
K1	30		3	SPRING RING DIAM. 50
K1	31		1	SPRING RING DIAM. 78
	32	9098589000	1	HOSE SQUEEGEE
K2	33		2	CLAMP
	34	9098529000	1	BRUSH D.370 PROLENE PPL
	34*	9099006000	1	BRUSH D.370 PROLITE PPL
	34*	9099007000	1	BRUSH D.370 UNION MIX
	34*	9099008000	1	BRUSH D.370 MID GRIT 240
	34*	9099009000	1	BRUSH D.370 MIDLITE GRIT
	[35]*	9099010000	1	PAD HOLDER D.350MM
	[35]*	L00190797	1	PAD 14 355MM BROWN 5 PCS
	[35]*	L00190798	1	PAD 14 355MM RED 5 PCS
	[35]*	L00190799	1	PAD 14 355MM WHITE 5 PCS
	[35]*	L00306400	1	PAD 14 355MM GREEN 5 PCS
	K1	9098991000	1	RINGS SPRING KIT
	[K2]	9098996000	1	HARDWARE DECK KIT

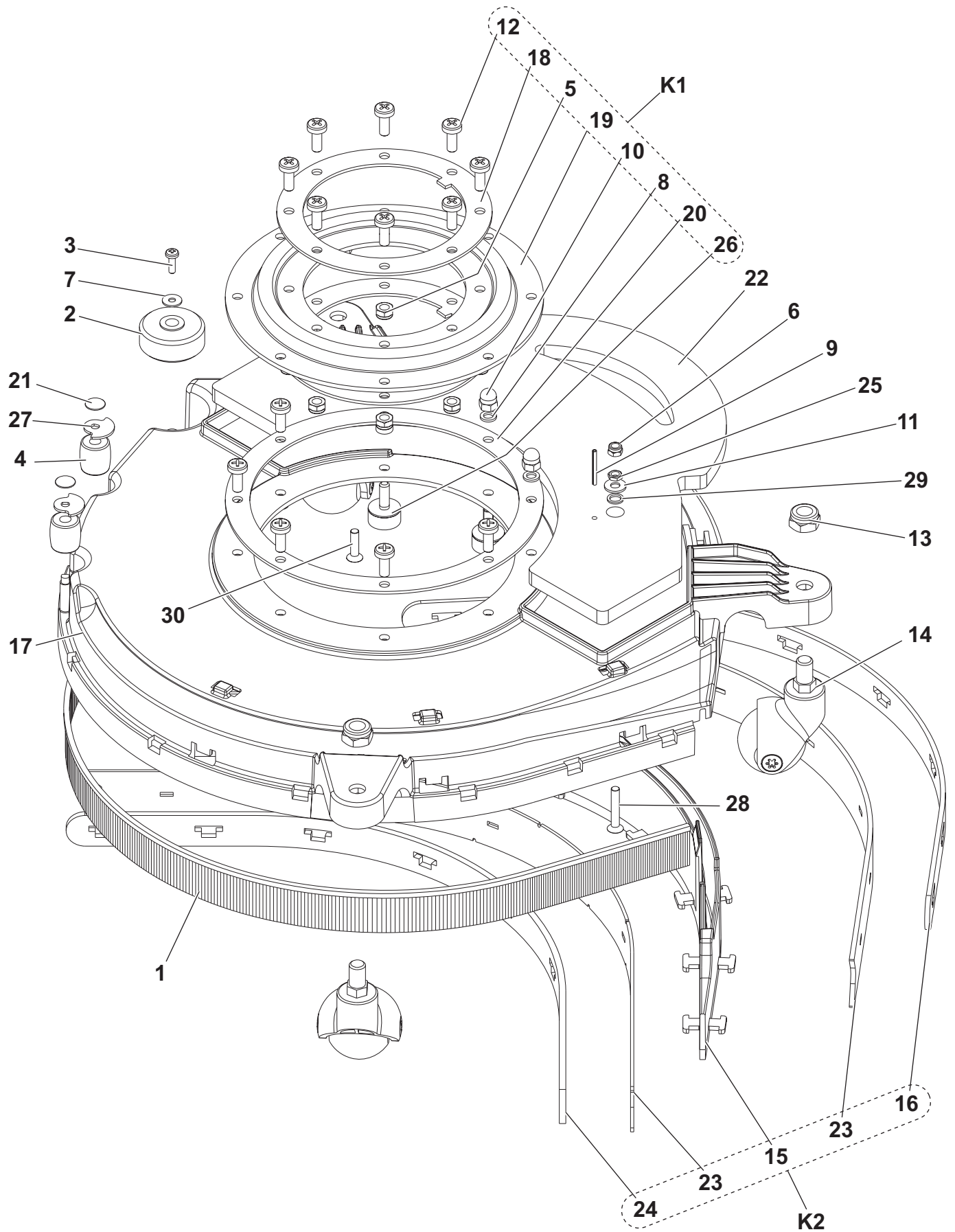

2011-01	BRUSH DECK			
	SC350			15

Kit	Item No.	Ref. No.	Qty	Description
	1	9098475000	1	BRUSH LINEAR
	2	L08603027	1	ROLLER BUMPER
K3	3		1	SCREW 3.9X13 UNI6954
	4	L08603402	2	ROLLER
K1	5		13	NUT HEX SELFLOCK M6 SS
K3	6		1	NUT SELF L. M5 UNI7474
K3	7		1	WASHER 4X12 UNI6592 SS
K1	8		3	WASHER
K3	9		1	PIN
K1	10		3	NUT M10X1.5 UNI7473
K3	11		2	WASHER 5X15 UNI6593 SS
K1	12		13	SCREW M6X16 UNI7687 SS
K3	13		3	NUT SELF L. M10 UNI7474
	14	9098307000	3	WHEEL CASTOR D.42
K2	15		1	SQUEEGEE BODY 455MM/18
K2	16		1	STRAP REAR SQUEEGEE 455MM
	17	9098400000	1	COVER BRUSH DECK
K1	18		2	FLANGE 132X100X2
K1	19	9098402000	1	COUPLING RUBBER DECK
K1	20		1	FLANGE 195X165X2
	21	9098473000	2	COVER PIN
	22	9098477000	1	COUNTERWEIGHT
K2	23	9099027000	1	BLADES SQUEEGEE KIT
K2	24		1	STRAP FRONT SQUEEGEE 455
K3	25		2	NUT HEX M5 UNI5589 SS
K1	26	9098620000	3	VIBRATION DAMPING M6 D.20X10
	27	9098633000	2	PLATE BUMPER FIX
K3	28		1	SCREW M5X30 UNI5933 SS
K3	29		2	WASHER M10 UNI8842A SS
K3	30		1	SCREW M5X20 UNI5933 SS
	K1	9098997000	1	COUPLING DECK KIT
	K2	9098998000	1	SQUEEGEE KIT
	[K3]	9098999000	1	HARDWARE COVER DECK KIT

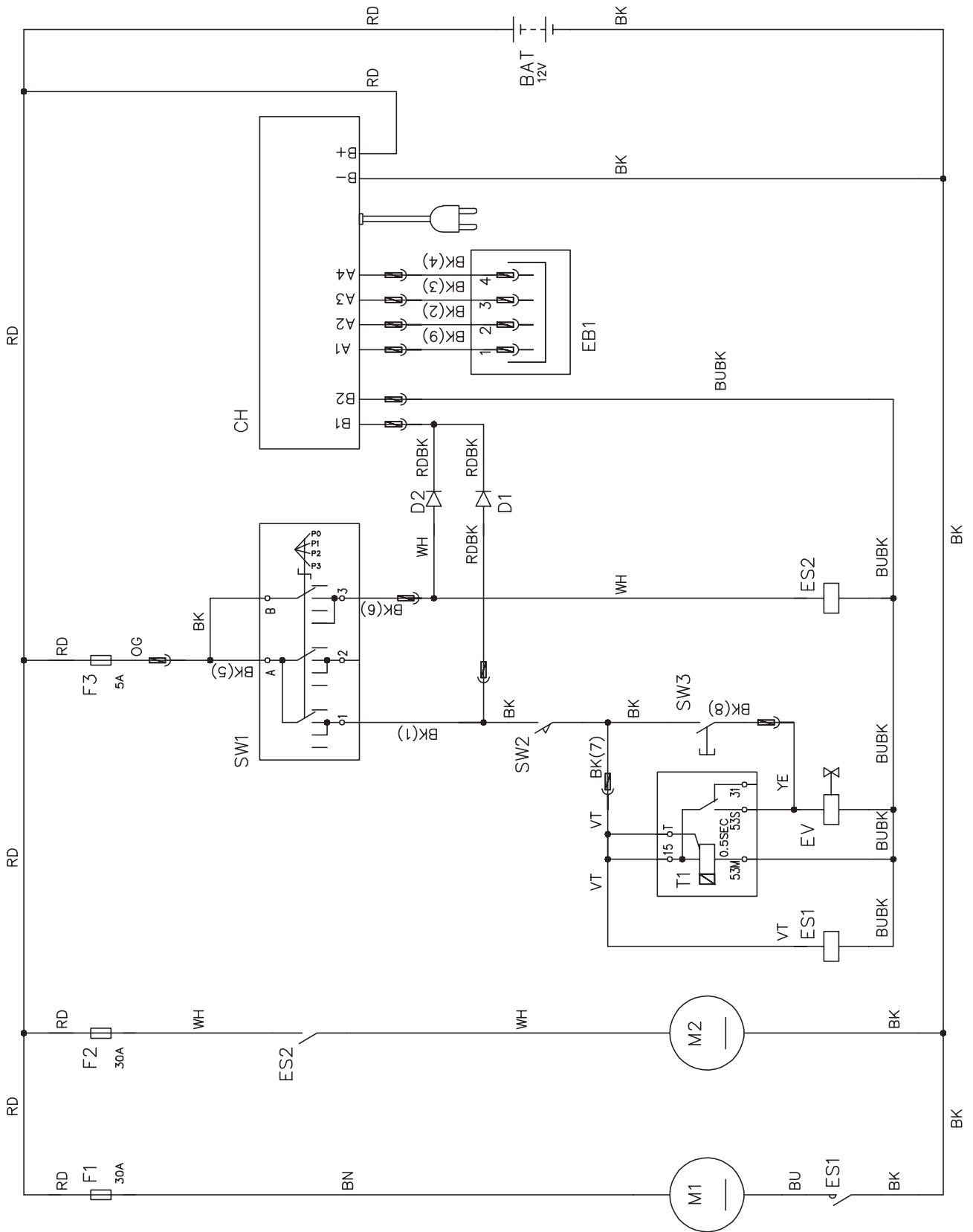

Key	Ref. No.	Description
BAT	1464484000	BATTERY 12V 87AhC5 AGM
CH	9098188000	BATTERY CHARGER
D1	-	DIODE
D2	-	DIODE
EB1	146 3073 000	BATTERY CHARGER LEVEL BOARD
ES1	9098424000	BRUSH MOTOR CONTACTOR
ES2	9098441000	VACUUM MOTOR RELEAY
EV	9098112000	DETERGENT SOLENOID VALVE
F1	909 5706 000	BRUSH CIRCUIT BREAKER
F2	145 8513 000	VACUUM FUSE (30 A)
F3	145 9852 000	ROTATIVE SWITCH FUSE (5 A)
M1	9097976000	BRUSH MOTOR
M2	9098111000	VACUUM MOTOR
SW1	9098405000	ROTATIVE SWITCH
SW2	40263A	SWITCH M1-EV
SW3	L08603153	DETERGENT SWITCH
T1	9098375000	SOLENOID VALVE TIMER
BK	-	BLACK
BU	-	LIGHT BLUE
BN	-	BROWN
GN	-	GREEN
GY	-	GREY
OG	-	ORANGE
PK	-	PINK
RD	-	RED
VT	-	VIOLET
WH	-	WHITE
YE	-	YELLOW

RECOMMENDED SPARE PARTS

2011-01

18

SC350

Ref. No.	QTY	DESCRIPTION
NORMAL WEAR		
9099027000	1	BLADE SQUEEGEE KIT
ORDINARY MAINTENANCE		
9099127000	1	GASKET TANK COVER KIT
9098319000	1	GASKET
9099042000	1	CABLE DECK
9098111000	1	MOTOR VACUUM 12V 200W (M2)
9098327000	1	GASKET VACUUM MOTOR
9098655000	1	FILTER VACUUM MOTOR
9097976000	1	REDUCTION GEARMOTOR 12V (M1)
L08812480	1	HUB.BRUSH
9098589000	1	HOSE SQUEEGEE
9098307000	3	WHEEL CASTOR D.42
9098997000	1	COUPLING DECK KIT
9098998000	1	SQUEEGEE KIT
EXTRA-ORDINARY MAINTENANCE		
9098237000	2	WHEEL D.200MM
9098188000	1	CHARGER BATTERY 12V 12A (CH)
9098697000	1	VALVE WATER COMPLETE
9098992000	1	PIPES KIT
9098760000	2	CONNECTOR 50A GREY
909 5706 000	1	BREAKER CIRCUIT 30A (F1)
9098112000	1	SOLENOID VALVE 12V (EV)
9098424000	1	SWITCH ELECTROMAGNETIC 12V 70A (ES1)
9098441000	1	RELAY 12V (ES2)
9098375000	1	TIMER CYCLICAL (T1)
145 8513 000	1	FUSE BLADE 30A UL (F2)
145 9852 000	1	FUSE 5A (F3)
9098405000	1	SWITCH ROTATIVE 4 POSITIONS (SW1)
40263A	1	SWITCH DPDT (SW2)
OPTIONALS		
1464484000	1	BATTERY 12V 87AhC5 AGM
9099011000	1	HOSE FILLING KIT
9099006000	1	BRUSH D.370 PROLITE PPL
9099007000	1	BRUSH D.370 UNION MIX
9099008000	1	BRUSH D.370 MID GRIT
9099009000	1	BRUSH D.370 MIDLITE GRIT
9099010000	1	PAD HOLDER
L00190797	1	PAD 14 355MM BROWN 5 PCS
L00190798	1	PAD 14 355MM RED 5 PCS
L00190799	1	PAD 14 355MM WHITE 5 PCS
L00306400	1	PAD 14 355MM GREEN 5 PCS



Advance

14600 21st Avenue North
Plymouth, MN 55447-3408
www.advance-us.com
Phone: 800-989-2235
Fax: 800-989-6566
©2011 Nilfisk-Advance, Inc.

A Nilfisk-Advance Brand