

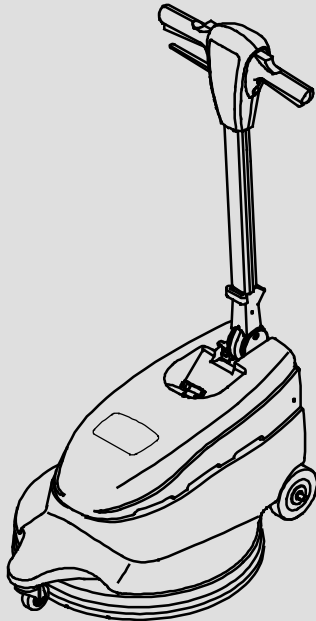

# BR-2000-DC

Dust Control Burnisher

## Parts Manual



Model Part No.:  
9007349 - BR-2000-DC (120V)  
1000152 - BR-2000-DC (100V)



[www.tennantco.com](http://www.tennantco.com)

**NOBLES**  
[www.nobles.com](http://www.nobles.com)

9007379  
Rev. 01 (03-2014)



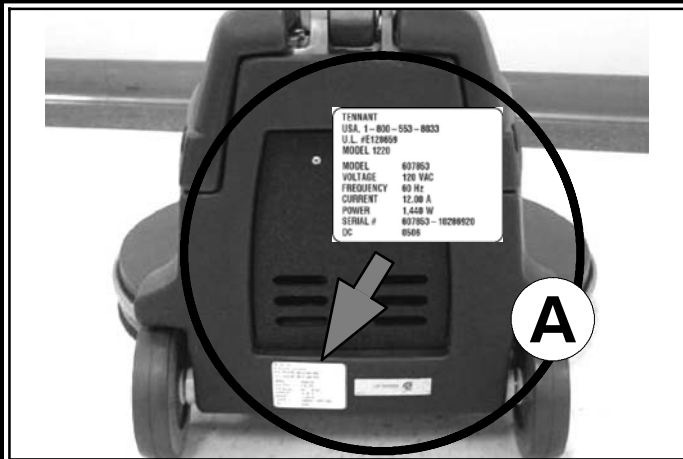

TENNANT  
USA, 1-800-553-8033  
U.L.#122809  
MODEL 1220  
MODEL 607853  
VOLTAGE 120 VAC  
FREQUENCY 60 Hz  
CURRENT 12.00 A  
POWER 1,440 W  
SERIAL # 607853-1029820  
DC 0506

Ref	Part No.	Serial Number	Description	Qty.
1	82681	(000000- )	Bracket Wldt, Lpg Mount	1
∇ 2	63810	(000000- )	Latch Assy, Lpg Tank Mtg, W/Nut	4
▲ 3	51839	(000000- )	Nut Adjustable, Lpg Tank Mtg	2
4	49263	(000000- )	Tie, Cable	3
(C)	82556	(000000- 001039)	Bracket, Vaporizer	1
	54930	(000000- )	Vaporizer	1

**HOW TO ORDER PARTS - See diagram above**

Only use TENNANT Company supplied or equivalent parts. Parts and supplies may be ordered online, by phone, by fax or by mail.

Follow the steps below to ensure prompt delivery.

1. (A) Identify the machine model.
2. (A) Identify the machine serial number from the data label.
3. (B) Ensure the proper serial number is used from the parts list.
4. Identify the part number and quantity.  
Do not order by page or reference numbers.
5. Provide your name, company name, customer ID number, billing and shipping address, phone number and purchase order number.
6. Provide detail shipping instructions.

- (C) ∇ - identifies an assembly  
▲ - identifies parts included in assembly

**Please fill out at time of installation for future reference.**

Model No. - \_\_\_\_\_  
 Serial No. - \_\_\_\_\_  
 Machine Options - \_\_\_\_\_  
 Sales Rep. - \_\_\_\_\_  
 Sales Rep. phone no. - \_\_\_\_\_  
 Customer ID Number - \_\_\_\_\_  
 Installation Date - \_\_\_\_\_

**Tennant Company**

PO Box 1452  
 Minneapolis, MN 55440  
 Phone: (800) 553-8033 or (763) 513-2850

www.tennantco.com  
 www.nobles.com

Specifications and parts are subject to change without notice.

Copyright © 2010, 2014 TENNANT Company, Printed in U.S.A.

<b>CN</b>	<p><b>如何订购部件 - 参见下表</b></p> <p>仅使用 TENNANT 公司提供的或同等部件。部件和供应可以在线订购，通过电话、传真或邮件订购。请遵循下面的步骤确保及时交付。</p> <ol style="list-style-type: none"> <li>1. (A) 确定机器型号。</li> <li>2. (B) 从数据标签确定机器序列号。</li> <li>3. (C) 确保使用部件列表中的正确序列号。</li> <li>4. 确定部件号和数量。 不要按页面或参考编号订购。</li> <li>5. 提供您的姓名、公司名称、客户 ID 号、付帐和送货地址、电话号码和采购单编号。</li> <li>6. 提供详细的送货说明。</li> </ol> <hr/> <p>(D) ▽ - 确定组件 ▲ - 确定组件中包含的组件</p>	<p><b>请在安装时填写供未来参考。</b></p> <p>型号 - _____</p> <p>序列号 - _____</p> <p>机器选项 - _____</p> <p>销售代表 - _____</p> <p>销售代表电话号码 - _____</p> <p>客户 ID 编号 - _____</p> <p>安装日期 - _____</p>
-----------	--	--

<b>ES</b>	<p><b>CÓMO SOLICITAR PIEZAS - Consulte el diagrama anterior.</b></p> <p>Utilice sólo las piezas suministradas por TENNANT Company o piezas equivalentes. Puede solicitar las piezas a través de internet, por teléfono, por fax o por correo.</p> <p>Siga los siguientes pasos para que la entrega sea rápida.</p> <ol style="list-style-type: none"> <li>1. (A) Indique el modelo de máquina.</li> <li>2. (B) Indique el número de serie de la etiqueta de datos.</li> <li>3. (C) Asegúrese de que indica el número de serie correcto de la lista de piezas.</li> <li>4. Indique la cantidad y el número de la pieza. No realice el pedido indicando el número de página o el de referencia.</li> <li>5. Incluya su nombre, el nombre de la empresa, el ID de cliente, las direcciones de envío y facturación, el número de teléfono y el número del pedido de compra.</li> <li>6. Facilite instrucciones de envío.</li> </ol> <hr/> <p>(D) ▽ - identifica un conjunto ▲ - identifica piezas de un conjunto</p>	<p><b>Rellene estos datos cuando realice la instalación para utilizarlos como referencia en el futuro.</b></p> <p>Nº modelo - _____</p> <p>Nº serie - _____</p> <p>Opciones de la máquina - _____</p> <p>Vendedor - _____</p> <p>Nº teléfono vendedor - _____</p> <p>Nº cliente - _____</p> <p>Fecha de instalación - _____</p>
-----------	--	---

<b>FR</b>	<p><b>COMMENT COMMANDER DES PIÈCES DÉTACHÉES - Voir le schéma ci-dessus.</b></p> <p>Utilisez uniquement des pièces fournies par la société TENNANT ou équivalentes. Les pièces et fournitures peuvent être commandées en ligne, par téléphone, fax, ou par courrier.</p> <p>Suivez les étapes ci-dessous pour assurer une livraison rapide.</p> <ol style="list-style-type: none"> <li>1. (A) Identifiez le modèle de la machine.</li> <li>2. (B) Identifiez le numéro de série de la machine, à partir de l'étiquette signalétique.</li> <li>3. (C) Assurez-vous que le numéro de série correct est utilisé à partir de la liste de pièces détachées.</li> <li>4. Identifiez le numéro de pièce et la quantité. Ne commandez pas par page ou numéros de référence.</li> <li>5. Fournissez votre nom, le nom de votre société, votre numéro d'identification de client, l'adresse de facturation et d'expédition, le numéro de téléphone et le numéro du bon de commande.</li> <li>6. Fournissez des instructions d'expédition détaillées.</li> </ol> <hr/> <p>(D) ▽ - identifie un assemblage ▲ - identifie les pièces composant l'assemblage</p>	<p><b>A remplir au moment de l'installation à titre de référence.</b></p> <p>Nº du modèle - _____</p> <p>Nº de série - _____</p> <p>Options de la machine - _____</p> <p>Agent commercial - _____</p> <p>Nº tél. de l'agent commercial - _____</p> <p>Numéro d'identification client - _____</p> <p>Date d'installation - _____</p>
-----------	--	---

<b>JP</b>	<p><b>パーツの発注方法 ? 上記の図を参照してください</b></p> <p>TENNANT社製のパーツまたは同等品のみをお使いください。パーツやサプライ品のご注文は、オンライン、電話、FAX、または手紙でお願いいたします。確実にお届けできるように、以下の情報お知らせください。</p> <ol style="list-style-type: none"> <li>1. (A) 製品のモデル名をお知らせください。</li> <li>2. (B) 製品のデータラベルに印刷されているシリアル番号をお知らせください。</li> <li>3. (G) パーツリストを参照して、シリアル番号が正しいかご確認ください。</li> <li>4. パーツ番号と数量をお知らせください。マニュアル/カタログのページ番号や参照番号でのご注文はご遠慮ください。</li> <li>5. お客様のお名前、会社名、顧客ID番号、請求/発送先住所、電話番号、注文書番号をお知らせください。</li> <li>6. 発送に関するご希望があれば、明記してください。</li> </ol> <hr/> <p>(D) ▽ - アセンブリを示します ▲ - アセンブリに含まれるパーツを示します</p>	<p><b>後日確認できるように、設置時に記入してください。</b></p> <p>モデルNo. - _____</p> <p>シリアルNo. - _____</p> <p>製品のオプション - _____</p> <p>販売代理店 - _____</p> <p>販売代理店の電話番号 - _____</p> <p>顧客ID番号 - _____</p> <p>設置日 - _____</p>
-----------	---	---



**STANDARD PARTS**

---

GENERAL RECOMMENDED MAINTENANCE  
ITEMS ..... 7  
HANDLE GROUP ..... 8  
BASE GROUP ..... 10  
PAD DRIVER GROUP ..... 12  
ELECTRICAL DIAGRAM, 120V/100V ..... 14

# GENERAL RECOMMENDED MAINTENANCE

---

# GENERAL RECOMMENDED MAINTENANCE

## GENERAL RECOMMENDED MAINTENANCE ITEMS

Part No.	Serial Number	Description	Qty.	
600189	(00000000-	) Caster, Swivel, 2.5d 1.1w, .50- 13 Stem	1	
1005629	(00000000-	) Skirt Assy, Dust- Cntrl	1	
1001369	(00000000-	) Wheel, 05.0d 1.25w 0.50b	2	
1000617	(00000000-	) Bag, Fltr, Cloth [2370/Ultrashine] (Standard)	1	
1001923	(00000000-	) Bag, Fltr [Ultrashine, 1pick=1pkg] (Optional)	1	
▽	1000584	(00000000-	) Motor, 115vac 2000rpm 1.50hp	1
▽	1000622	(00000000-	) Motor, 100vac 2100rpm 1.30hp (Japan)	1
▲	22117	(00000000-	) Brush, Carbon [1pick=1pc]	4
▲	190753	(00000000-	) Rectifier, 60a/600v	1
	1000703	(00000000-	) Seal	1
	611788	(00000000-	) Pad, 20.0[Burnish, Hairblend,1pick=1ctn] (1Ctn = 5Pads)	1
▽	1210491	(00000000-	) Driver Assy, Pad, 20d	1
▲	32506	(00000000-	) Device, Centering, Rh Pad Retainer	1
▲	1205787	(00000000-	) Collar, Locking, Pad Driver, 6.1"	1

▽ ASSEMBLY

▲ INCLUDED IN ASSEMBLY

HANDLE GROUP

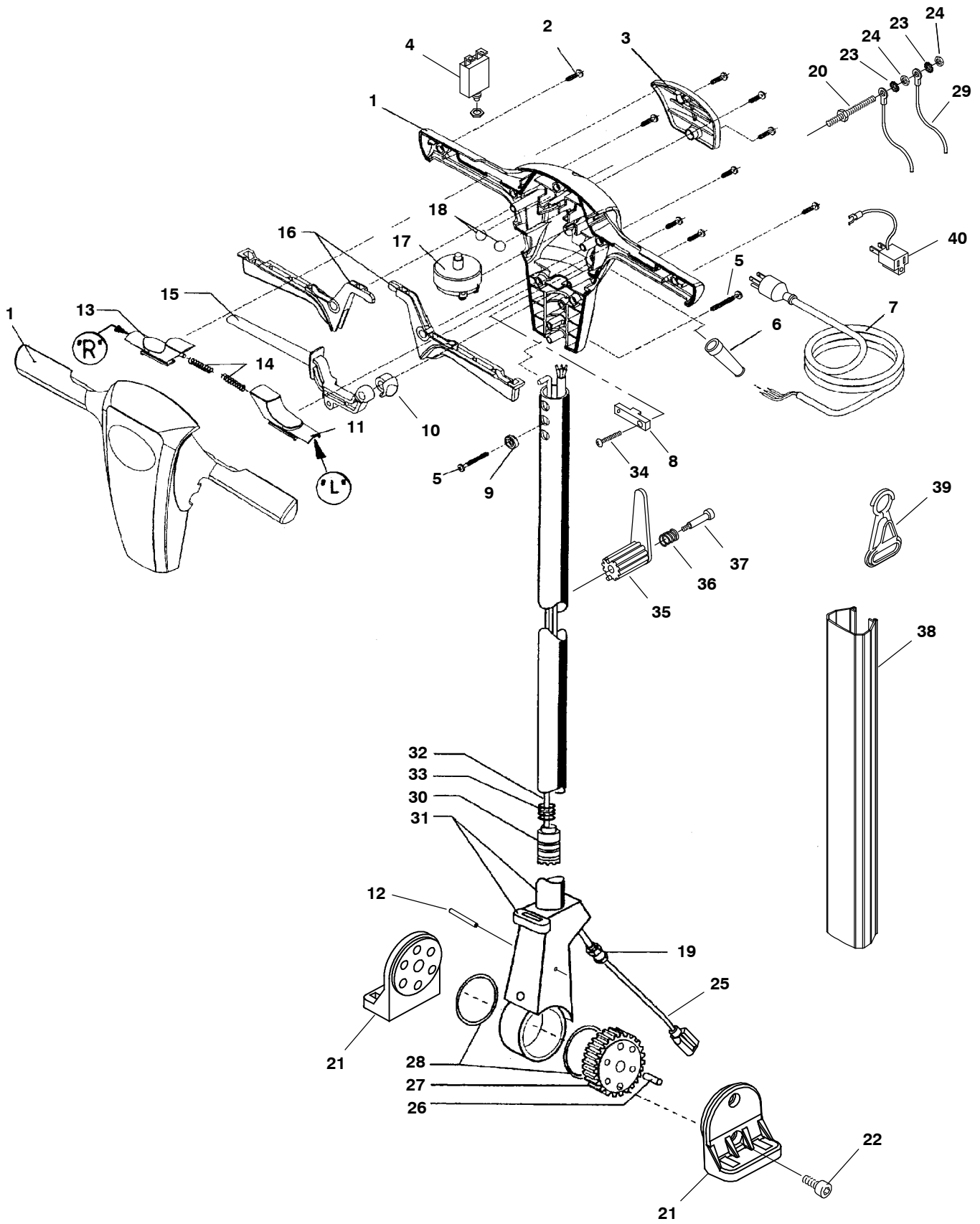



## HANDLE GROUP

Ref.	Part No.	Serial Number	Description	Qty.	
▽	1038953	(00000000-	) Handle Assy, Burnisher, 120v [2370, Tj]	1	
▲	1	613272	(00000000-	) Vr, Handle Kit, Front & Rear [2370]	1
▲	2	1043573	(00000000-	) Screw, #10- 14 X 0.675, Spl[Shcs,Selftap]	9
▲	3	801003	(00000000-	) Cover [2100 Series]	1
▲	4	1000209	(00000000-	) Circuitbreaker, 17.0a	1
▲	5	1043572	(00000000-	) Screw, #10- 14 X 01.5, Spl[Shcs Selftap]	2
▲	6	801448	(00000000-	) Sleeve, Rbr, 0.59b 0.91d	1
▲	7	1005511	(00000000-	) Cord, Power, 14/3 [23meter, Sjt]	1
▲	8	1034174	(00000000-	) Clamp, Cable, Pa6 White	1
▲	9	1034176	(00000000-	) Bushing, Flng, 05mmb 12mmd 08mml [Pa6]	1
▲	10	1034951	(00000000-	) Plug, Hole, Handle, Gray [Spectrasheen]	1
▲	11	801005	(00000000-	) Vr, Lock, Slide, Lh [2100 Series]	1
▲	12	1034924	(00000000-	) Pin, Roll, 04mmd X 40mml	1
▲	13	801004	(00000000-	) Vr, Lock, Slide, Rh [2100 Series]	1
▲	14	801013	(00000000-	) Spring, Extn, 0.27od 0.02wir 01.71	2
▲	15	1034945	(00000000-	) Lever, Adjmt, Handle	1
▲	16	801006	(00000000-	) Lever [2100 Series]	2
▲	17	1035649	(00000000-	) Switch, Dpst, Momentary [2370]	1
▲	18	801035	(00000000-	) Ball [2100 Series]	2
▲	19	1035729	(00000000-	) Strainrelief, Bshg, [2370]	1
▲	20	1034952	(00000000-	) Screw, Hex, M4 X 0.7 X 12, Dbl Thrd	1
▲	21	1000307	(00000000-	) Handle, Pivot, Half	2
▲	22	49609	(00000000-	) Screw, Soc, M8 X 1.25 X 16, 12.9	4
▲	23	140061	(00000000-	) Washer, Lock, Ext, 08, Pl	2
▲	24	42368	(00000000-	) Nut, Hex, Std, M4 X 0.70, 8	2
▲	25	1000517	(00000000-	) Cord, 14ga /3, 35.0l, W/ Receptacle,Gray	1
▲	26	1034155	(00000000-	) Pin, Roll, 06mmd X 36mml	2
▲	27	1034872	(00000000-	) Gear, Lock, Handle	1
▲	28	612422	(00000000-	) Seal, Org, Gear Seat	2
▲	29	1000512	(00000000-	) Wire, 14ga 07.9l Blk Ferrule /.14ring	1
▲	30	1034873	(00000000-	) Plunger, Notched Pin	1
▲	31	1040948	(00000000-	) Vr, Tube Assy, Handle [2370]	1
▲	32	1000476	(00000000-	) Rod, Release [Spectrasheen]	1
▲	33	1013295	(00000000-	) Spring, Cmpr [2100 Series]	1
▲	34	1043573	(00000000-	) Screw, #10- 14 X 0.675, Spl[Shcs,Selftap]	2
▲	35	603104	(00000000-	) Hook, Cord, Blk [Quick- Release]	1
▲	36	603108	(00000000-	) Spring, Cmpr, Switch	1
▲	37	140239	(00000000-	) Bolt, Shld, .38d X 1.75, .31- 18	1
▲	38	1000760	(00000000-	) Cover, Handle [2370]	1
	39	130176	(00000000-	) Clip, Cord, Strainrelief [Belt] (Optional)	1
	40	989611	(00000000-	) Adapter, Ground [Pse] (Japan)	1

▽ ASSEMBLY

▲ INCLUDED IN ASSEMBLY

BASE GROUP

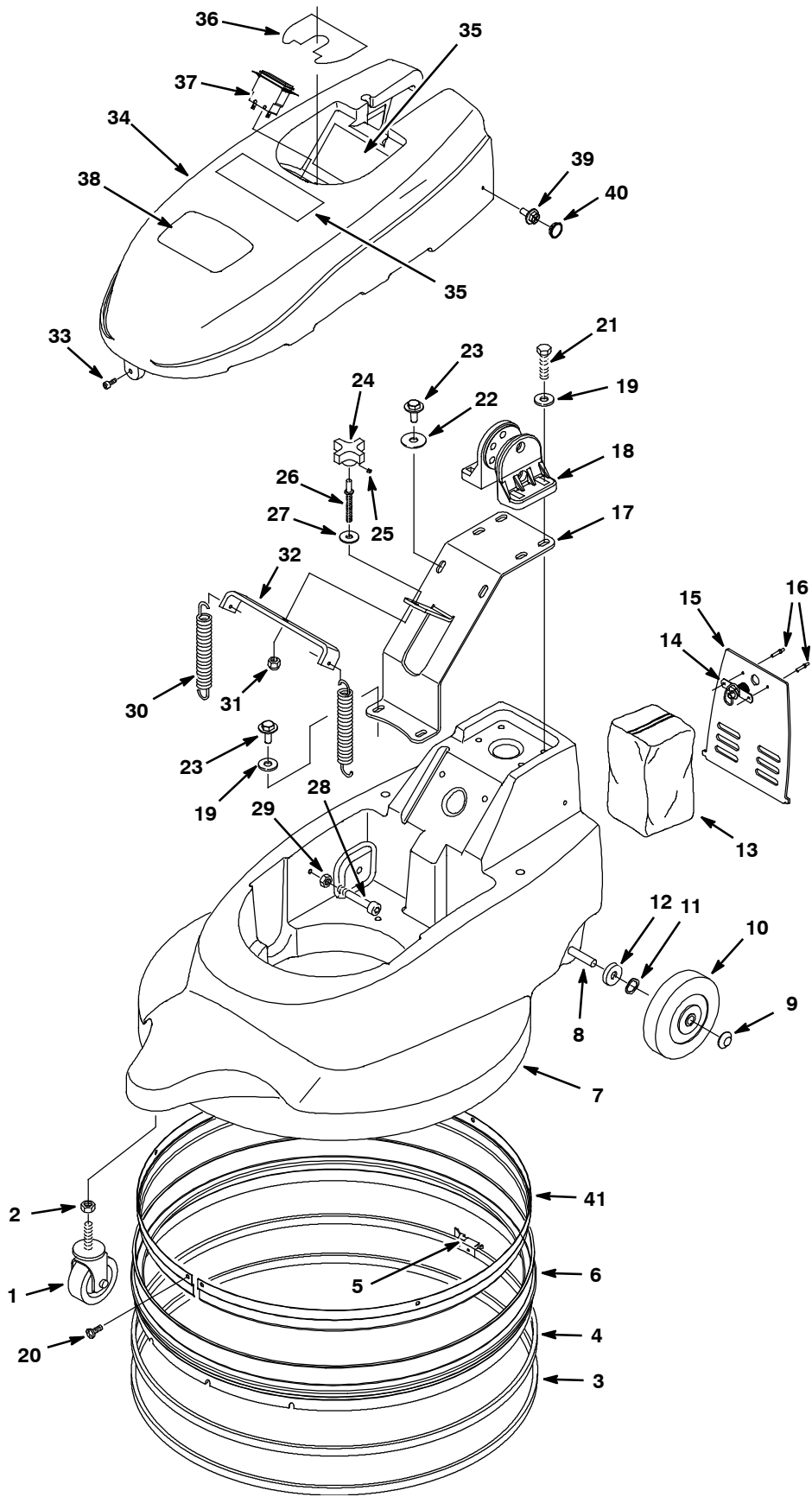

## BASE GROUP

Ref.	Part No.	Serial Number	Description	Qty.
1	600189	(00000000-	) Caster, Swivel, 2.5d 1.1w, .50- 13 Stem	1
2	140509	(00000000-	) Nut, Hex, Jam, .50- 13, Ss	1
3	630613	(00000000-	) Bumper, Strip, 1626mm [L03]	1
4	069767094	(00000000-	) Band Kit, 72 Inch, Replmt	1
5	602044000	(00000000-	) Fastener [Adjusting, S- 2500 Skirt]	1
6	1005629	(00000000-	) Skirt Assy, Dust- Cntrl	1
7	9007664	(00000000-	) Base, 20.0, Rm- Blk, Afmkt	1
8	1001193	(00000000-	) Axle, .5d X 14.72l	1
9	103019	(00000000-	) Nut, Retainer, 0.50d 0.29l, Ss	2
10	1001369	(00000000-	) Wheel, 05.0d 1.25w 0.50b	2
11	4252	(00000000-	) Washer, Flat, .50 Compression, Zn	2
12	140063	(00000000-	) Washer, Flat, 0.51b 1.25d .31, Nyl	2
13	1000617	(00000000-	) Bag, Fltr, Cloth [2370/Ultrashine] (Standard)	1
13	1001923	(00000000-	) Bag, Fltr [Ultrashine, 1pick=1pkg] (Optional)	1
14	140962	(00000000-	) Latch, Cmpr, Spring, Knurled Knob, PI	1
15	1000277	(00000000-	) Bag, Door [Nobles]	1
16	140706	(00000000-	) Rivet, Blind, .125d, PI	2
17	1000225	(00000000-	) Bracket, Handle, Sppt	1
18	1000307	(00000000-	) Handle, Pivot, Half	2
19	140027	(00000000-	) Washer, Flat, 0.35b 0.75d .04, Ss	4
20	140350	(00000000-	) Screw, Pan, Phl, 10- 16 X 0.50, Ss[Typ25]	6
21	1016399	(00000000-	) Screw, Hex, M8 X 1.25 X 30, NI, Ss	4
22	140014	(00000000-	) Washer, Flat, 0.31b 1.50d, Fendr, PI	1
23	1020341	(00000000-	) Screw, Hex, M8 X 1.25 X 20, Ss, Sems	4
▽	24	600974	(00000000-) Knob, Star, 2.25d 4ear 1.1l .38id, Bshg	1
▲	25	140894	(00000000-) Screw, Set, Soc, 10- 32 X 0.25, Blk[Cppt]	1
	26	611865	(00000000-) Stud, Adjmt	1
	27	20536- 2	(00000000-) Washer, Flat, 0.50b 1.00d .03, Nyl	1
	28	200001486	(00000000-) Screw, Soc, M8 X 1.25 X 16	2
	29	200101017	(00000000-) Nut, Hex, Jam, M8 X 1.25	2
	30	1010685	(00000000-) Spring, Extn, 0.98od 0.11wir 03.8l	2
	31	36643	(00000000-) Nut, Hex, Lock, .38- 16, NI, Thin	1
	32	600194	(00000000-) Bracket, Spring	1
	33	200001483	(00000000-) Screw, Soc, M8 X 1.25 X 12, PI	1
▽	34	9007666	(00000000-) Cover, Motor, Rm- Cphg, Afmkt	1
▲	35	1026786	(00000000-) Label, Warning [Expl,Fire,Shk En/Fr/Es]	1
▽	34	9007841	(00000000-) Cover, Motor, Rm- Cphg, Afmkt, Tj	1
▲	35	613866	(00000000-) Label, Warning, 4 X 3, Tj[Ac Floor Mach] (Japan)	1
	36	612771	(00000000-) Label, Pad Press [2370]	1
	37	1011541	(00000000-) Gauge, Pad, Press 4- 16a D.C.	1
	38	1060465	(00000000-) Label, Logo, Cmdty, Dual, Small	1
	38	1060463	(00000000-) Label, Logo, Cmdty, Tco, Small	1
	39	1034731	(00000000-) Screw, Hex, M6 X 1.00 X 16, Ss, Sems	2
	40	130175	(00000000-) Plug, Hole, Rnd, 0.75d, Blk	2
	41	1005645	(00000000-) Shield, Skirt	1

▽ ASSEMBLY

▲ INCLUDED IN ASSEMBLY

PAD DRIVER GROUP

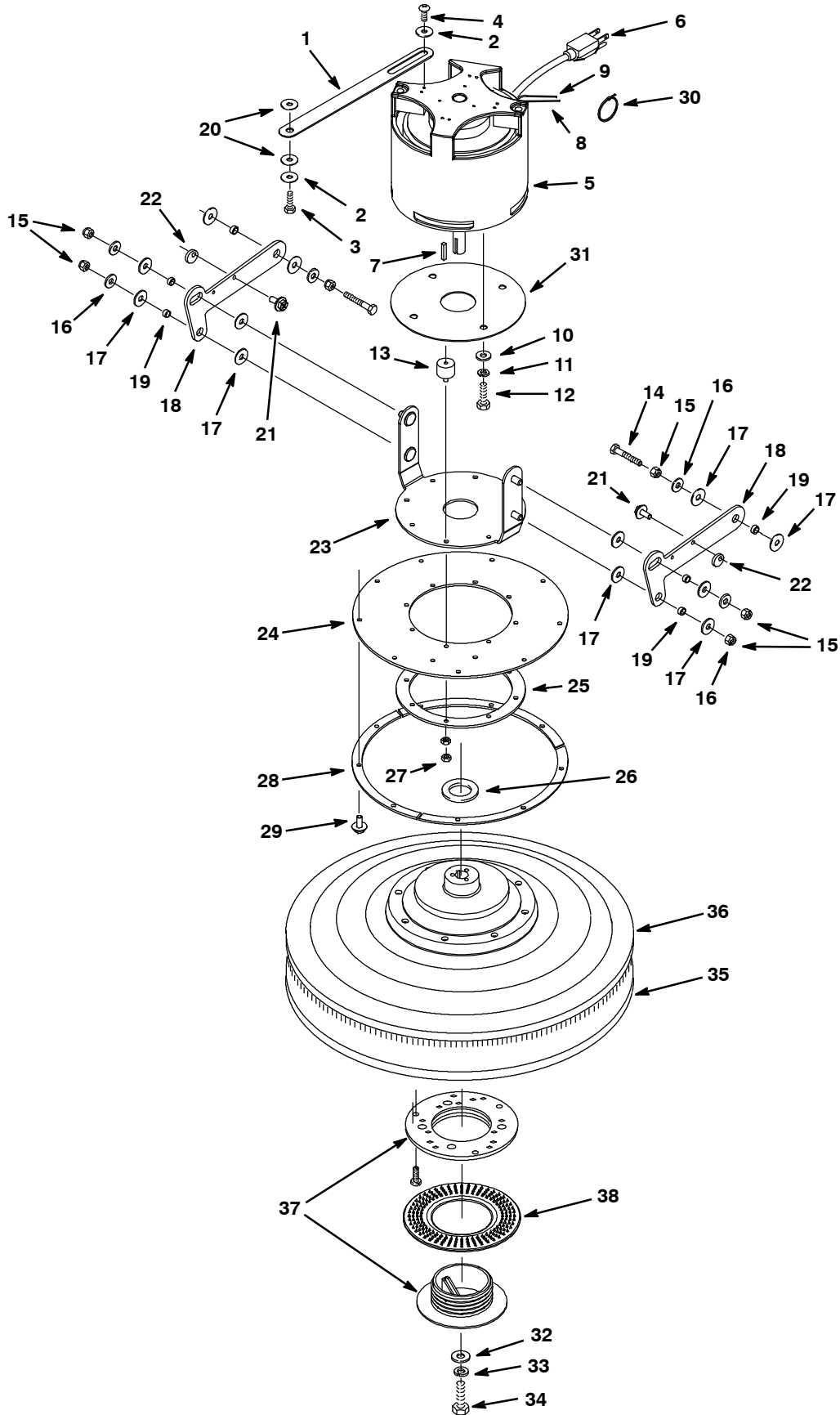

## PAD DRIVER GROUP

Ref.	Part No.	Serial Number	Description	Qty.	
1	613910	(00000000-	) Strap Kit, Replmt	1	
2	140003	(00000000-	) Washer, Flat, 0.25b 1.00d , Ss, Fendr	2	
3	15678	(00000000-	) Screw, Hex, M6 X 1.00 X 16, Ss	1	
4	140350	(00000000-	) Screw, Pan, Phl, 10- 16 X 0.50, Ss[Typ25]	1	
▽	5	1000584	(00000000-	) Motor, 115vac 2000rpm 1.50hp	1
▽	5	1000622	(00000000-	) Motor, 100vac 2100rpm 1.30hp (Japan)	1
▲		22117	(00000000-	) Brush, Carbon [1pick=1pc]	4
▲		190753	(00000000-	) Rectifier, 60a/600v	1
▲	6	1001679	(00000000-	) Cord, Power, 14/3, 024.0l Gray [Sjt]	1
▲	7	140628	(00000000-	) Key, Sq, 0.19 X 0.19, 1.00l	1
▲	8	1000483	(00000000-	) Wire, 14ga 15.8l Blk .25qf /.25qf	1
▲	9	1000484	(00000000-	) Wire, 14ga 15.8l White .25qf /.19ring	1
	10	140028	(00000000-	) Washer, Flat, 0.42b 1.00d .05, Ss	4
	11	140017	(00000000-	) Washer, Lock, Split, 0.38, Ss	4
	12	2949.5	(00000000-	) Screw, Hex, .38- 16 X 0.62, Ss	4
	13	1000409	(00000000-	) Mount, Stud / Plate	4
	14	140233	(00000000-	) Screw, Hex, .38- 16 X 1.75, Ss	2
	15	36643	(00000000-	) Nut, Hex, Lock, .38- 16, NI, Thin	6
	16	140028	(00000000-	) Washer, Flat, 0.42b 1.00d .05, Ss	6
	17	20536- 2	(00000000-	) Washer, Flat, 0.50b 1.00d .03, Nyl	12
	18	611859	(00000000-	) Bracket, Arm, Lift	2
	19	600191	(00000000-	) Sleeve, P/M, 0.38b 0.50d 0.2l, PI	6
	20	575600	(00000000-	) Washer, Flat, 0.25b 1.06d, Rbr, Neo	2
	21	1034731	(00000000-	) Screw, Hex, M6 X 1.00 X 16, Ss, Sems	2
	22	1001408	(00000000-	) Cam, Stop	2
	23	611862	(00000000-	) Bracket, Motor	1
	24	1000703	(00000000-	) Seal	1
	25	1000713	(00000000-	) Plate, Seal, Motor Mount	1
	26	069760023	(00000000-	) Washer, Flat, 0.77b 1.26d .03, Ss	1
	27	140524	(00000000-	) Nut, Hex, Lock, .25- 20, Kep	8
	28	1000711	(00000000-	) Plate, Base, Seal	3
	29	1034731	(00000000-	) Screw, Hex, M6 X 1.00 X 16, Ss, Sems	9
	30	130040	(00000000-	) Tie, Cable, Nyl, 06.0l .12w	1
	31	1001311	(00000000-	) Retainer, Seal	1
	32	25732	(00000000-	) Washer, Flat, 0.36b 1.25d .09, PI	1
	33	140015	(00000000-	) Washer, Lock, Split, 0.31, Ss	1
	34	140221	(00000000-	) Screw, Hex, .31- 18 X 1.25, Ss	1
	35	611788	(00000000-	) Pad, 20.0[Burnish, Hairblend,1pick=1ctn] (1Ctn = 5Pads)	1
▽	36	1210491	(00000000-	) Driver Assy, Pad, 20d	1
▲	37	32506	(00000000-	) Device, Centering, Rh Pad Retainer	1
▲	38	1205787	(00000000-	) Collar, Locking, Pad Driver, 6.1"	1

▽ ASSEMBLY

▲ INCLUDED IN ASSEMBLY

ELECTRICAL DIAGRAM, 120V/100V

