

CHARGER 2000BP/3000BP

IMPORTANT SAFETY INSTRUCTIONS

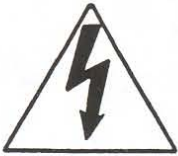

**READ AND UNDERSTAND ALL INSTRUCTIONS
BEFORE OPERATING OR SERVICING MACHINE**
THIS MACHINE IS INTENDED FOR COMMERCIAL USE ONLY

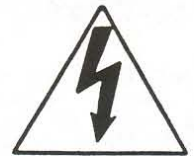

DANGER!

**Failure to Observe These Instructions Can Cause Personal Injury to
Machine Operator or By-Standers and Possible Property Damage.**

ALWAYS wear eye protection and protective clothing when working with the batteries.
The batteries contain **ACID**. Avoid Contact with skin or clothing.

Antidote: **EYES** Flush with water 15 minutes. Call physician.

INTERNAL—Drink water or milk. Follow with Milk of Magnesia, beaten egg or vegetable oil.
Call physician.



Service should be done only by authorized, trained personnel.

Charge batteries in a well ventilated area with Battery Compartment Cover Removed.

Batteries generate explosive gasses - keep sparks, flames, burning cigarettes or other ignition sources away at all times.

Batteries are heavy - two (2) people are required for installation or removal.

Never lay anything on top of batteries to prevent arcing.

Turn off all switches during installation and service.

To maintain machine balance, always slide batteries back into position as shown on battery installation decal.

Connect batteries as shown on battery installation decal to avoid shorting out batteries and electrical system.

Disconnect battery leads before performing any service or repairs.

ALWAYS make sure battery charger is fumed off when connecting/disconnecting to machine to prevent sparking.

ALWAYS operate this machine from the rear control panel, not from the side.

NEVER operate machine in an explosive atmosphere (grain dust or gas vapor).

NEVER use flammable liquids (gas, kerosene, solvents or thinners) to clean floor.

ALWAYS turn off master switch when changing pads.

NEVER operate machine with skirts or covers removed.

NEVER leave machine unattended.

**PERSONAL INJURY AND PROPERTY DAMAGE FROM MACHINE OVERTURNING,
BATTERIES FALLING OUT OF MACHINE OR BATTERIES LEAKING ACID CAN OCCUR
IF YOU DO NOT FOLLOW THESE PRECAUTIONS:**

NEVER attempt to operate machine unless you have been trained in its operation.

Follow these rules when working on or near loading docks and ramps:

- A. **ALWAYS** be sure ramp is secured to vehicle before attempting to load/unload.
- B. **ALWAYS** use extreme caution when operating machine on a ramp or loading/unloading a machine into or out of a truck. Use extreme caution if ramp is wet, oily or covered with cleaning chemicals.
- C. **NEVER** turn machine on an incline.
- D. **NEVER** stop machine on a ramp.
- E. **NEVER** attempt to climb a grade of more than 20°.
- F. **NEVER** park machine near a dock or on ramps.
- G. **NEVER** leave machine unattended.

SAVE THESE INSTRUCTIONS



WARNING: FAILURE TO OBSERVE THESE INSTRUCTIONS CAN CAUSE MACHINE DAMAGE AND POSSIBLE PERSONAL INJURY TO MACHINE OPERATOR.

1. **NEVER** spray machine with water.
2. **NEVER** allow battery charging plugs to get wet. Battery charging plugs will short out if wet.
3. **NEVER** operate machine when charger is plugged in.
4. **NEVER** store machine near furnaces, boilers or open flame which may damage machine.
5. **NEVER** store any item on the machine.
6. **ALWAYS** protect machine from freezing temperatures.

ASSEMBLY

Inspect machine for hidden freight damage. If damage is found, save all packing materials and notify your local office of trucking company that you wish to file a freight claim.

Remove the bolts and washers securing the wheels to the hold down brackets. Push the machine back about 6" to clear the hold down brackets.

Figure A—You **MUST** reinstall the bolts and washers securing the wheel to the axle to prevent damage to the wheels and axles.

Figure B—Carefully read the label at the rear of the machine describing the three machine positions.

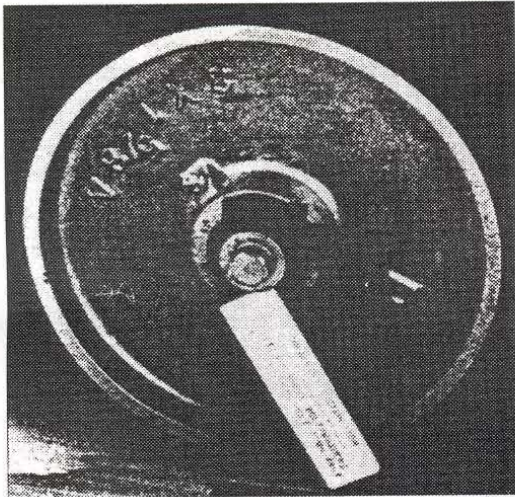

Figure A

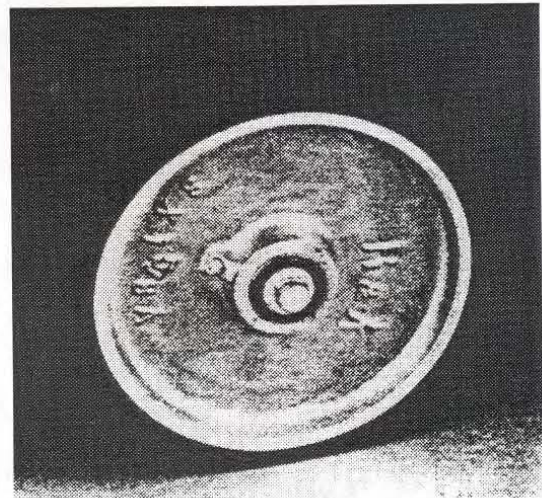
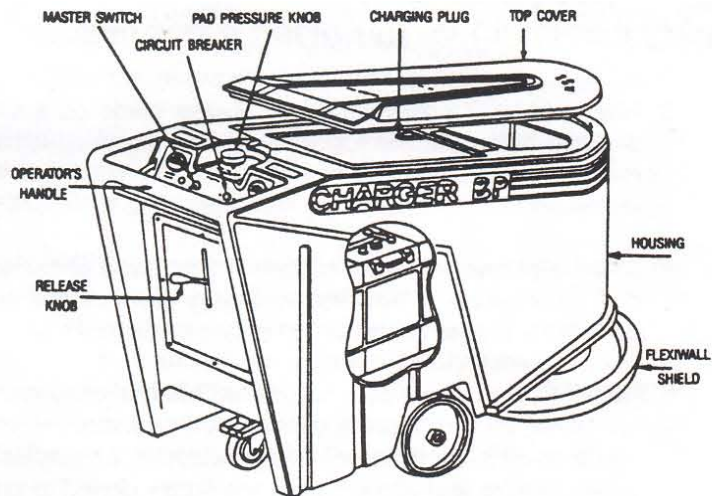

Figure B

Place the machine in the #2 "transport" position by raising up on the lever at the back of the machine. Remove the foam packing from under the pad driver assembly.

Lift the machine off the pallet using the handle and the lower front lip of the body as lifting points. **DO NOT** lift using the Flexiwall Shield® Assembly.



- After attaching a new pad and placing machine in Operating position, adjust Pad Pressure Knob until the arrow (Below Left) points to the Release Knob.
- Push machine forward when starting to avoid possible damage to the floor.
- Increase or decrease Pad Pressure as needed, after machine starts.

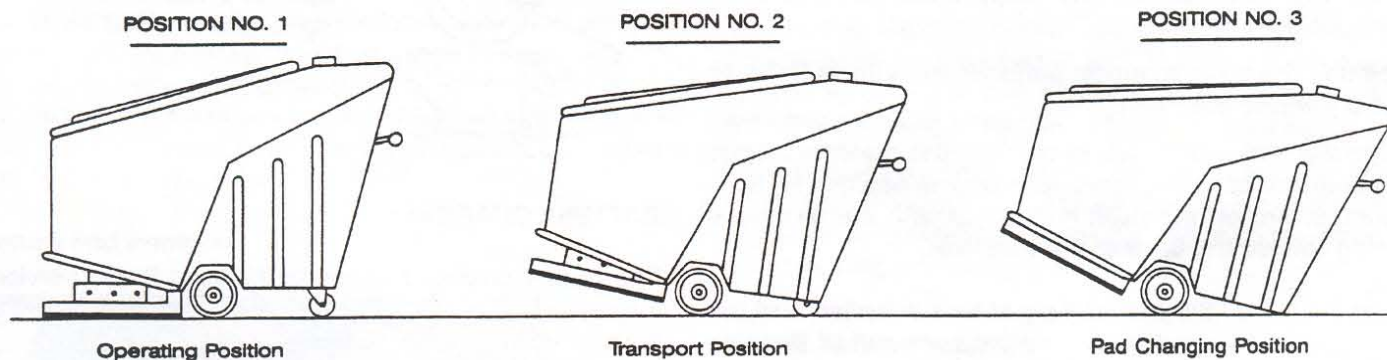

Before operating and/or attaching/detaching the pads, you must read these instructions:

- The machine can be lowered in the back, which raises up the front for ease of transportation and pad attachment/detachment.
- The machine arrives in Position No. 1 (the operating position). To lower the back of the machine to Position No. 3 (the pad changing position), hold operator handle with one hand and move the Release knob up with other hand. Lower the machine slowly. Let go of Release knob after machine begins to lower. The machine will stop in Position No. 2. Move release knob up again and lower the machine slowly to floor (Position No. 3). Pad can now be easily attached/detached.
- To raise machine to Position No. 2 (the transport position), lift up on Operator handle with both hands. The machine will stop in Position No. 2. The machine can now be transported.
- To raise the machine back to Position No. 1, lift up on Operator handle with one hand and move Release knob up with the other hand. Let go of Release knob after machine starts to raise up. The machine will stop in Position No. 1.

BATTERY INSTALLATION AND CARE

WARNING: EXTREME CAUTION MUST BE EXERCISED WHEN HANDLING BATTERIES

The type of battery used in the Charger 2000BP/3000BP is filled with corrosive acid. Never lay metal objects across the top of the battery cover or terminals.

The Charger 2000BP/3000BP requires three (3) 12 Volt, 185 amp-hour batteries, part #44-106-1.

Height: 13-1/4" Length: 15-1/2" Width: 7" Weight: 125#

We recommend that two people lift and install the batteries.

WARNING

Read Before Installing Batteries to Prevent Injury or Damage to Machine. Also Read Warnings on Front Page of this Manual.

CAUTION: Make sure that the master switch is in the down (off) position.

Position the three required batteries as follows (refer to battery wiring diagram).

Align the three batteries in front of the machine. From the operator position, make sure that all positive (+) connections are on the right hand side with the terminals facing toward the back of the machine.

Make sure that the two battery cables supplied and the two cables attached to the machine are out of the way and not underneath the batteries. Grasping the handles on the sides of the battery, install the rear battery first, then install the second battery, moving it all the way forward, leaving the center space for the final battery.

WARNING: Do not Connect Final Battery Terminal until wiring diagram on the front of the machine has been thoroughly examined. Failure to connect the batteries properly can cause damage to the machine or personal injury.

Make sure all positive (+) battery terminals from the operator position are on the right hand side. Carefully connect the front battery positive (+) terminal to the middle battery negative (-) terminal. Connect the long negative (-) cable from the back of the machine to the front battery. Keeping your face turned away from the battery compartment, carefully connect the positive (+) cable to the positive (+) connection remaining on the back battery. Be sure all terminal clamps are tight. If sparking occurs, check to be sure that all connections are as shown in the diagram and all terminal connections are tight.

BATTERY WATER ADDITIONS

1. Always check acid level in battery **BEFORE** charging. The acid should be visible in the cell. If the acid is not visible, the top of the plates will be damaged during the charge cycle. Add just enough water to be visible.
2. After the batteries are fully charged, again check the acid level. If the level is at the triangle, no adjustment is necessary. If the level is below the triangle, add water to bring level to the triangle. **DO NOT OVERFILL.**

3. Final acid level adjustments are always made on a fully charged battery. If the adjustments are made on a discharged battery, the acid will boil over, due to the normal increases in acid level during recharge.
4. Boiled over acid will cause battery and machine corrosion. It will also cause a reduction in battery performance and service life due to the reduction in acid strength.
5. Spilled electrolyte must be neutralized using a solution of 1 Lb. baking soda to 1 gallon of water. Any corrosion may be scrubbed off by using a non-metallic brush. Rinse with clear water. Ensure that all vent caps are tightly closed to prevent solution from getting into the battery.

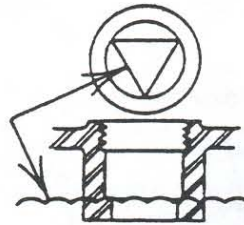

Check liquid level of battery acid. Adjust to proper level, top of triangle, with distilled water only when batteries are **FULLY CHARGED.**

BATTERY CHARGING

The battery charger supplied by National Super Service is fully automatic and energy saving. Operation is simple and safe by following 6 easy steps.

1. Remove battery cover during charging.
2. Connect charging plug to 36 Volt battery receptacle.
3. Plug cord into **GROUND**ED 120 volt A C. outlet.
4. Charger will perform a self-test prior to starting the charge cycle. The red and green lights will indicate the charge cycle status. The charger will run at least two (2) hours regardless of battery charge.
5. To interrupt the charge cycle, push the STOP button.
6. The charger must be disconnected from the batteries for 5 seconds before reconnecting to restart.

The battery charger operates only long enough to properly recharge the batteries. This controlled recharge reduces water consumption and increases battery service life by not over-charging.

For complete battery charger operating instructions, see supplied owner's manual for more detailed instructions on trouble shooting and use of the charger.

Refer to the enclosed list of authorized MAC service centers for in and out of warranty service on your charger.

PAD INSTALLATION

Remove the pad that is supplied in the battery compartment of the machine. Remove the center hole of the pad and **step on the center** of the pad to compress the edges around the center hole. This will allow easier installation of the pad holding cup.

With the machine in the pad changing position, #3, carefully center the pad on the driver. As is shown on the label on the front of the machine, center pad holding cup screw in the hole on the bottom of the machine through the pad.

Holding the pad cup up against the bottom of the pad driver, turn the pad driver clockwise until the pad cup is tight and stops turning.

CAUTION: Pads **must** be installed concentric (evenly aligned) with the outside edge of the pad driver. Failure to follow these precautions will cause excessive machine vibration, a reduction in pad life and produce unsatisfactory burnishing results. **Failure to install the pad cup tightly may allow the pad to be thrown from the driver. Never operate the machine without a Flexiwall Shield® in position over the pad.**

CAUTION: The Charger 3000BP design and pad speed require particular care in pad choice and installation. Use only NSS HY-PER SPEED® laminated 20" pads 28-004-1 Blonde or 28-005-1 Blue, 19" Polyester pads or equivalent for best results. Laminated pads greatly reduce pad growth and distortion at HY-PER SPEED. Pads **must** be installed concentric (evenly aligned) with the outside edge of the pad driver. Failure to follow these precautions will cause excessive machine vibration, a reduction in pad life and produce unsatisfactory burnishing results.

Setting Pad Pressure



Figure C

Pad pressure relates to buffing performance. Too much pad pressure will give uneven results and may cause circuit breaker to blow. Too light pad pressure will also give poor results and no contact with the floor. New pads are manufactured in different thicknesses; however, ALL pads will thin down during use and require periodic adjustment of pad. Therefore, follow procedure below:

ALWAYS start with ALL pad pressure OFF the floor. Increase pad pressure on the floor in small increments to prevent damage to the floor.

CAUTION: Too Much pad pressure may permanently damage floor.

The adjustment knob is a simple method of setting the pad pressure based on the thickness of the pad.

To increase pad pressure, turn the knob counter clockwise.

To decrease pad pressure, turn the knob clockwise.

If the circuit breaker blows on the machine, immediately reduce pad pressure by one full turn or more on the adjustment knob clockwise. Reset circuit breaker and try machine.

NEW PADS - Always **decrease** pad pressure three turns after installing a new pad. Move machine forward after starting machine and fine tune operating rpm. Failure to decrease pad pressure can cause an amp overload, blowing machine circuit breaker.

OPERATION

What Floor System Works Best With The Charger 2000BP/3000BP.

Dry polishing or burnishing works best with the Charger 2000BP/3000BP. Use mop on restorers rather than spray buff systems to restore the shine.

Spray buffing is time consuming, uses more pads because they become loaded with floor finish, and can cause overloading of the machine's circuit breaker.

HOW THE CHARGER 2000BP/3000BP WORKS

The Charger 2000BP/3000BP utilizes a 2-1/2" HP permanent magnet motor to drive the 20" pad. The pad pressure is adjustable by turning a knob on the top of the machine, which will either increase or decrease the pad pressure.

The level of pad pressure is indicated on the dial on the right-hand side of the control panel. The pad is adjusted properly when the arrow on average stays in or on the green arrow indicating proper rpm.

Due to imperfections in the floor, the pad rpm will change slightly. Periodic adjustment may be necessary to keep the dial running in the green. Too much pad pressure (dial pointing in the red) may cause the circuit breaker to disconnect the circuit to the motor. If this happens, reduce the pad pressure, push the black button that says "70" and continue running the machine.

To Begin Operation

Make sure that the correct pad (7/8" to 1") x 20" has been properly installed on the pad driver with pad holding cup and ring in place.

You are now ready to run the machine.

WARNING: MACHINE MUST BE MOVING AT ALL TIMES WHEN PAD IS ROTATING OR FLOOR MAY BE DAMAGED.

Turn the master switch to "on", check the level of battery work range (put machine on "charge" if not in the high range).

Push the machine forward slightly and squeeze the deadman switch lever to activate pad driving motor.

With the machine moving forward, watch the rpm meter for the average needle position on the meter. Adjust the black knob in the center of the control panel counter-clockwise to **increase** the pad pressure. It will move the rpm indicator needle more toward the right, or red area.

Adjust the knob clockwise to **decrease** the pad pressure, increasing the rpm's which moves the needle to the left. Adjust until the rpm meter needle averages in the area of the green arrow indicating proper rpm.

NEW PADS - Always **decrease** pad pressure three turns after installing a new pad. Move machine forward after starting machine and fine tune operating rpm. Failure to decrease pad pressure can cause an amp overload, blowing machine circuit breaker.

WARNING: Never operate machine with arrow in the red area of the gauge or damage to machine from overload may result.

Floors that have high or low spots will cause the rpm meter to enter into the red area occasionally. This is to be expected and will cause no harm to the machine. If you operate the machine continuously in the red area, the circuit breaker, just to the left of the rpm meter, can and will blow, indicating too much pad pressure or load. Push the button to reset, decrease pad pressure by 2 or 3 turns or more on the adjustment knob, change or turn the pad; otherwise, damage to the machine will result.

Operating the machine with higher than recommended pad pressure in the red area will shorten the operating time per battery charge. Maximum operating time can be achieved by adjusting pad pressure throughout the buffing cycle.

MAINTENANCE

MOTOR -

The motor used on the Charger 2000BP/3000BP requires very little service. Using compressed air, blow out the entire motor every 60 days. Pay close attention to the carbon brush area. Accumulated dirt will cause excessive carbon brush arcing, reduced brush life, poor machine performance and possible motor damage.

CARBON BRUSHES -

Inspect every 1000 hours of use for uneven wear and pitting. Replace carbon brushes when they have worn to a length of 3/8". Failure to replace carbon brushes will cause poor machine performance and possible motor damage.

WHEEL/CASTER -

Every 30 days, lubricate the wheels/caster with an industrial grade bearing grease. Failure to lubricate wheels/caster will cause the machine to maneuver with difficulty and premature failure of the wheels/caster and bearing. Figure D and E.

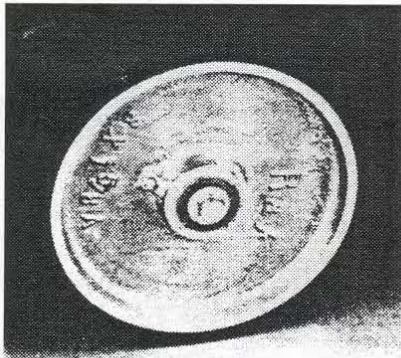

Figure D

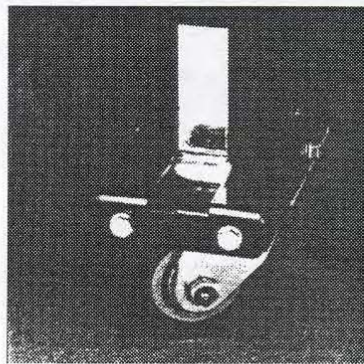

Figure E

PAD PRESSURE/ PIVOT LINKAGE -

Every 60 days, inspect ALL connections in the pad pressure adjustment and pivot linkage assembly. All linkage must move freely and smoothly to ensure proper machine operation. Lubricate each part as required with small amount of grease such as Lubriplate. Failure to lubricate these components may make it impossible to adjust the pad pressure or place machine into all three positions.

DUST CONTROL SYSTEM -

Weekly, check vac hose for connections to Flexiwall Shield® and filter bag. When filter bag is more than one-half (1/2) full, dispose old bag and replace with new bag. Inspect Flexiwall Shield for dents, cracks and wear. A damaged Flexiwall Shield® will greatly reduce the buffing and dust control capabilities. Dirt build up on the velcro will cause a squeaking noise as the machine is pushed across the floor: Clean or replace velcro.

BATTERIES -

See page #1 and page #3.

POLYETHYLENE BODY -

Weekly, clean with aerosol cleaner, "Armorall" type protector or wipe with a damp cloth. Never spray machine with water.

Battery Meter Gauge

Turn the switch to the "on" position. Check to see that red light near battery meter on left-hand side is lighted.

With master switch "on", check battery meter for charge indication. If needle is in the red area on the left-hand side, marked "recharge", the batteries are too low to operate and should be recharged.

The middle, green area, indicates whether or not the batteries are in the high or low range.

The right-hand side of the gauge indicates (when the battery charger is connected and charging and switch is on) the level of the charge in the batteries, whether high, low or in between.

When needle is in the far right, red area, shown as high, charging of the batteries is complete.

TROUBLE SHOOTING

PROBLEM	CAUSE	SOLUTION
Pad Does Not Turn	<p>Low Battery Charge. Loose Battery Cable. Circuit Breaker Has Tripped.</p> <p>Worn Motor Carbon Brushes. Pad Load Adjustment Knob out of Adjustment. Microswitch not engaged.</p>	<p>Recharge Batteries. Tighten & Clamp Battery Cables. Reduce Pad Pressure/Change P Reset Breaker. Change Carbon Brushes. Adjust knob until motor will turn on. Adjust mounting bracket.</p>
Machine Pushes Hard	Worn Wheel or Caster.	Grease Wheels or Replace.
Uneven Floor Buffing	Worn Pads. Motor out of Alignment.	Change Pads. Call NSS Service Center for Rep
Machine Vibrates	Pad is Torn or Not Centered.	Center Pads. Change Pad. Use Correct Pad. Check Pad Driver for Damage & Replace if Necessary.
Circuit Breakers Trips	<p>Pad Pressure too Heavy.</p> <p>Spray Buffing.</p> <p>Pad Rubbing on Flexiwall Shield®</p>	<p>Reduce Pad Pressure. Run MacI in Green Area of rpm Meter. Do Not Spray Buff with Charger 2000BP/3000BP. Realign pad on driver or replace with new pad. Check pad size.</p>
Short Running Time On Battery Charge	<p>Dead Cell In Battery.</p> <p>Excessive Pad Pressure.</p> <p>Incorrect Pad.</p>	<p>Test Batteries and Replace. Reduce Pad Pressure. Use NSS Pads or Recommended Equivalent.</p>
Battery Charger Does Not Turn On	<p>Connection not made Between Battery Charger and Machine.</p> <p>Improper Charger Sequence.</p>	<p>Check Anderson Connectors for Proper Contact on Both Charger and Machine. Read Instructions on Battery Charger or in Instruction Manual.</p>

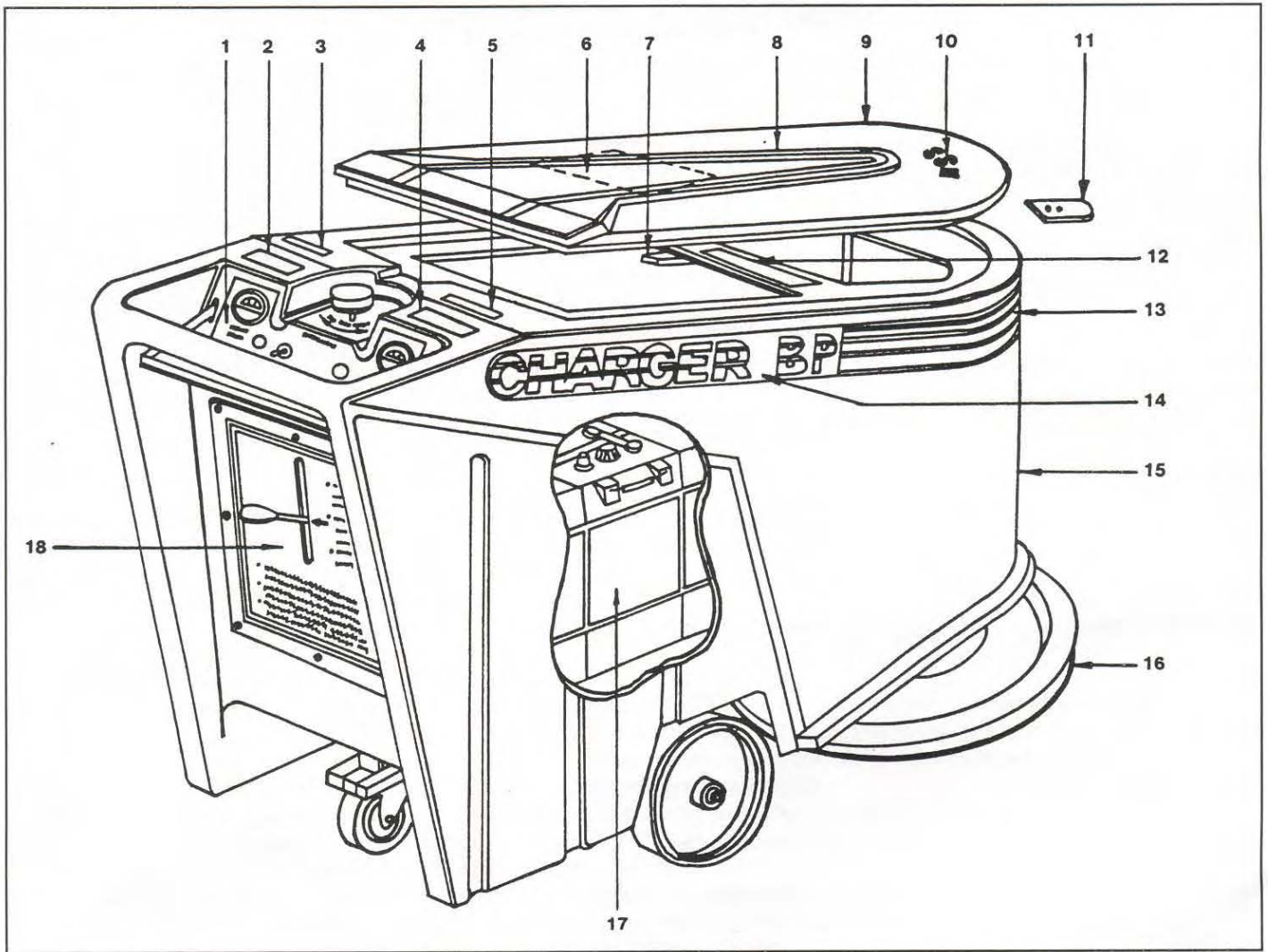

<u>ITEM NO.</u>	<u>PART NO.</u>	<u>DESCRIPTION</u>	<u>QUANTITY</u>
1	44-9-529-1	Instrument Panel Label	1
2	44-9-195-1	Charge/Storage Label	1
3	44-9-558-1	Caution Label -3000BP Only	1
4	44-9-541-1	Operation Label	1
5	44-9-559-1	Warning Label	1
6	44-9-203-1	Wiring Diagram Label	1
7	44-9-190-1	Anderson Plug	1
N/S	-----	6-32 x 7/8 Round Head Screw	2
N/S	-----	6-32 Keps Nut	2
8	44-9-198-1	Cover Label	1
9	44-9-011-9	Cover (Includes #6, 8, 10,11)	1
10	44-9-197-1	NSS Decal	1
11	44-9-018-6	Cover Latch	1
12	44-9-205-1	Warning & Battery Wire Label	1
N/S	-----	10-16 x 1/2 Pan Head Screw	2
13	44-9-202-1	Front Stripe Decal	1
14	44-9-208-1	Side Stripe Decal - 3000BP	2
	44-9-201-1	Side Stripe Decal - 2000BP	2
15	44-9-009-9	Housing	1
16	44-9-555-9	Flexiwall Shield® w/Vac Pickup (Yellow)	1
17	44-9-106-1	185 Amp/Hr.12 V Battery	3
18	44-9-539-1	Pad Label Decal	1

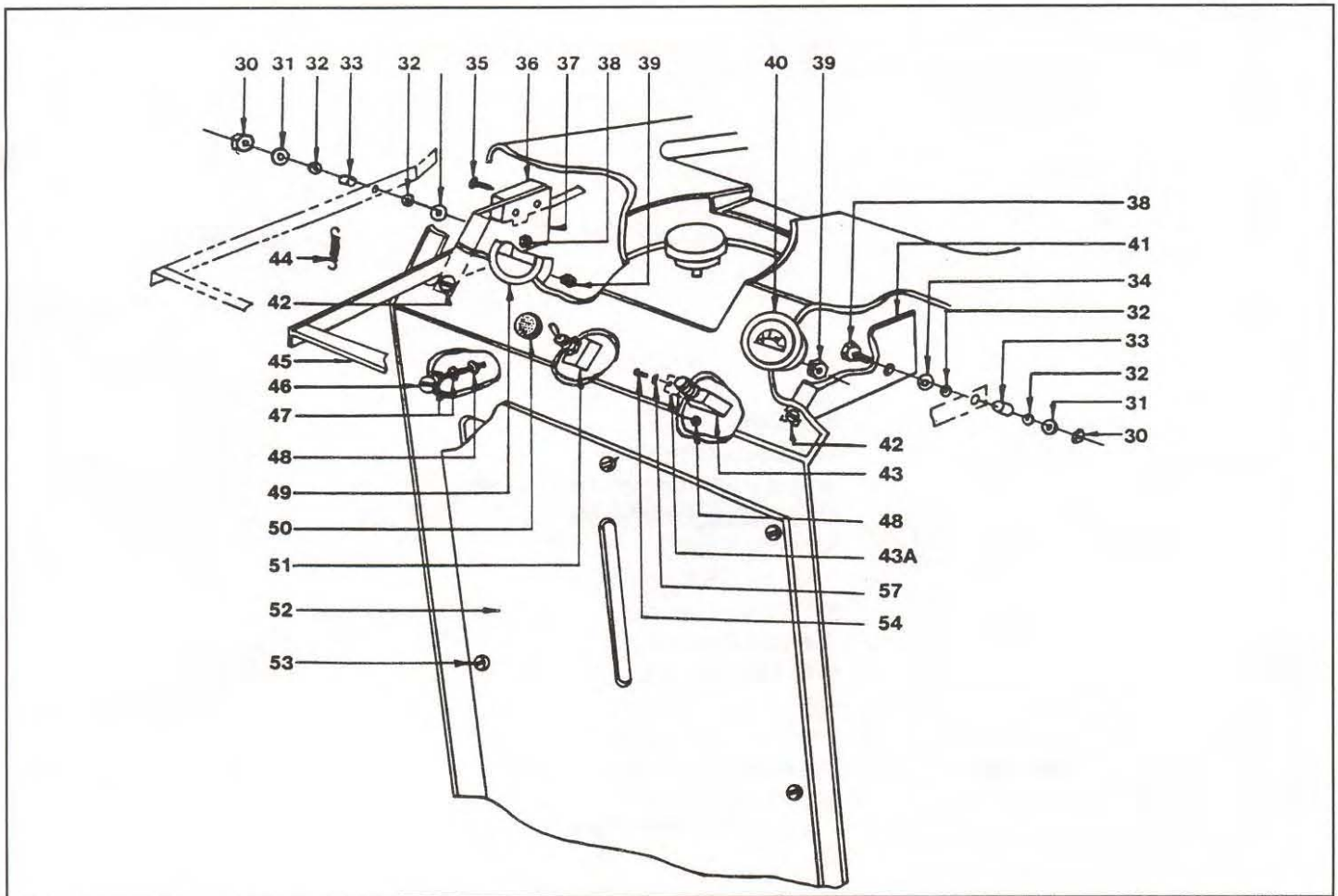

<u>ITEM NO.</u>	<u>PART NO.</u>	<u>DESCRIPTION</u>	<u>QUANTITY</u>
30	-----	1/4-20 Esna Lock Nut	2
31	-----	1/4 Flat Washer	2
32	44-9-062-1	36 Wave Washer	4
33	27-9-128-6	Spacer	2
34	-----	3/8 Flat Washer	2
35	-----	6-32 x 7/8 Round Head Screw	2
36	44-9-107-1	Switch	1
37	44-9-288-3	Left Switch Bracket	1
38	-----	1/4-20 x 1" Hex Bolt	2
39	-----	10-32 Hex Nut	4
40	44-9-104-1	RPM Meter	1
41	44-9-290-3	Right Switch Bracket	1
42	-----	10-24 x 1/2 Round Head Screw	4
43	44-9-070-9	Circuit Breaker - 70 AMP	1
43A	44-9-069-6	Mounting Plate	1
44	44-9-064-1	Spring	1
45	44-9-304-1	Handle	1
46	-----	10-24 x 2 Round Head Screw	1
47	-----	10-24 Hex Nut	2
48	-----	10-24 Hex Lock Nut	1
49	44-9-105-1	Battery Meter	1
50	44-9-109-1	Light	1
51	44-9-110-1	Switch	1
52	44-9-530-1	Back Panel	1
53	-----	10-16 x 1/2 Pan Head Screw	8
54	-----	10-24 x 5/8 Round Head Screw	2
55	-----	10-24 Esna Lock Nut	2
56	-----	10-24 Esna Lock Nut	2
57	-----	#10 Flat Washer	2

<u>ITEM NO.</u>	<u>PART NO.</u>	<u>DESCRIPTION</u>	<u>QUANTITY</u>
71	-----	1/4-20 x 3" Socket Head Cap Screw	1
72	27-9-128-6	Bushing Spacer	4
73	44-9-501-6	Adjustment Bracket	1
74	-----	1/2 SAE Flat Washer	1
75	44-9-063-1	Spring-Compression	1
76	44-9-505-3	Latch Assembly	1
77	-----	1/4-20 Esna Lock Nut	3
78	44-9-527-3	Control Panel	1
79	-----	3/8 Flat Washer	2
80	-----	1/8 x 3/4 Cotter Pin	2
81	44-9-052-1	Knob (includes item #82)	1
82	-----	10-32 x 3/8 Set Screw	1
83	44-9-504-6	Adjustment Rod	1
84	44-9-280-3	Top Support Bracket	1
85	-----	5/16-18 x 1 Round Head Screw	4
86	-----	5/16 Split Lock Washer	8
	-----	5/16-18 Hex Nut	4
	-----	5/16-18 x 3/4 Hex Bolt	6
89	-----	1/4-20 x 1 Hex Bolt	6
90	-----	1/4 Split Lock Washer	7
91	-----	5/16 Flat Washer	4
92	44-9-536-1	Adjustment Stop	1
93	-----	1/4-20 x 3/8 Hex Bolt	3
94	44-9-056-1	Insulated Standoff	
95	-----	1/4-28 Hex Nut	2
96	-----	1/4 External Star Washer	6
97	44-9-103-1	Shunt	1
98	-----	#10 Split Lock Washer	4
99	-----	#10-24 x 1/2 Round Head Screw	2
100	-----	5/16 x 7/8 Flat Washer	4
101	44-9-281-3	Side Support Bracket	2
102	-----	1/4-20 x 5/8 Hex Bolt	1
103	-----	5/16 Hex Nut	2
104	44-9-101-1	Solenoid	1
105	-----	5/16 Esna Hex Nut	2
106	-----	#10-24 x 1-3.8 Rd. Hd. Screw	2
107	-----	#10 Flat Washer	2
108	44-9-532-6	Switch Bracket	1
109	44-9-107-1	Switch	1
110	-----	#6 External Star Washer	2
111	-----	#6-32 x 7/8 Rd. Hd. Screw	2
112	44-9-535-6	Spacer Guide	4
113	44-9-510-6	Catch Assembly	1
114	44-9-060-1	Knob	1
115	44-9-507-6	Latch Handle	1
116	-----	1/4 Flat Washer	2
117	-----	3/8 Bowed Washer	1

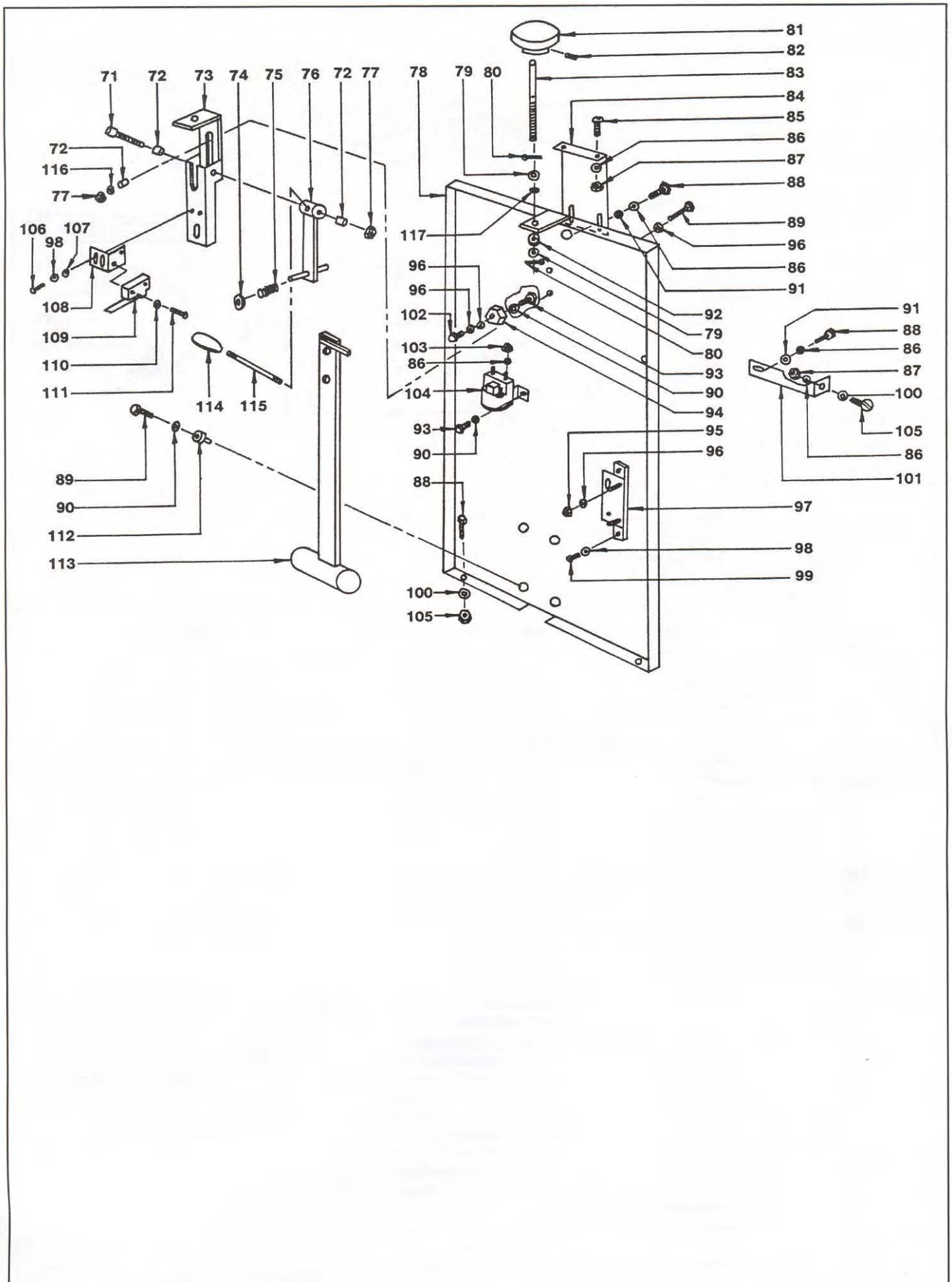

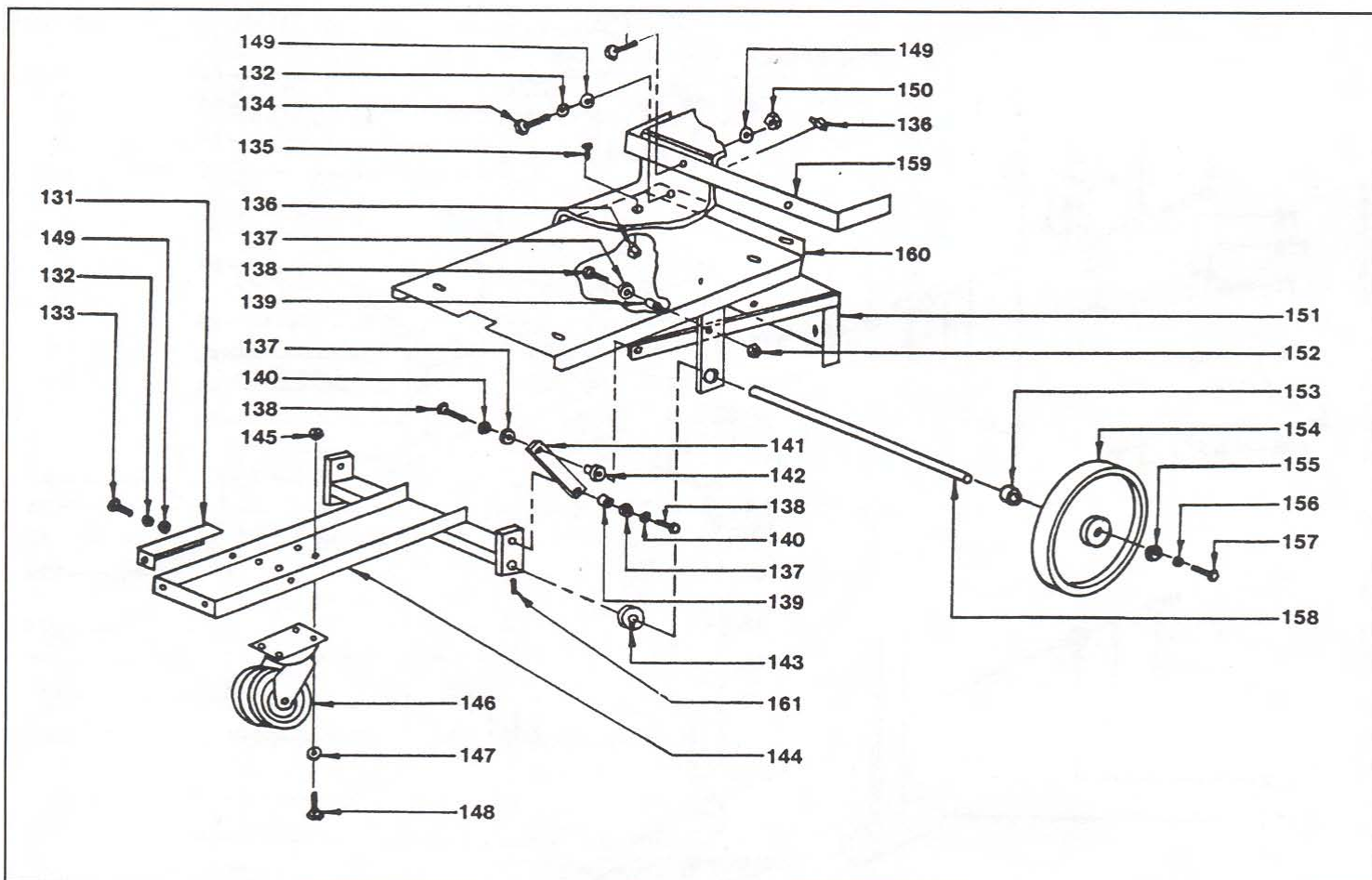

ITEM NO.	PART NO.	DESCRIPTION	QUANTITY
131	44-9-534-3	Left Support Bracket	1
N/S	44-9-533-3	Right Support Bracket	1
132	-----	5/16 Split Lock Washer	6
133	-----	5/16-18 x 3/4 Hex Bolt	4
134	-----	5/16-18 x 1" Hex Bolt	4
135	-----	5/16-18 x 1" Flat Head Screw	4
136	44-9-035-1	5/16-18 Tinnerman Nut	6
137	-----	1/2 SAE Flat Washer	6
138	-----	1/2-13 x 1-1/4 Hex Bolt	6
139	44-9-279-6	Pivot Bushing	4
140	-----	1/2 Split Lock Washer	4
141	44-9-513-6	Lift Arm	2
142	44-9-514-6	Lift Arm Spacer	2
143	44-9-537-1	Leg Support	2
144	44-9-520-3	Frame Assembly	1
145	-----	3/8-16 Esna Hex Nut	4
146	44-9-050-1	Caster	1
	44-9-039-1	Caster-Wheel Only	1
147	-----	3/8 Flat Washer	4
148	-----	3/8-16 x 1 Hex Bolt	4
149	-----	5/16 Flat Washer	8
150	-----	5/16 Esna Lock Nut	2
151	44-9-516-3	Pivot Weldment	1
152	-----	1/2-13 Esna Jam Nut	2
153	44-9-292-6	Wheel Spacer	2
154	44-9-051 -1	8" Wheel (Includes Bearings)	2
	44-9-048-1	Wheel Bearing	2
155	-----	3/8 x 1 Flat Washer	2
156	-----	3/8 Split Lock Washer	2
157	-----	3/8-16 x 1" Hex Bolt	2
158	44-9-254-6	Axle	1
159	44-9-277-3	Housing Brace	1
160	44-9-517-3	Base Weldment	1
161	-----	1/4-20 x 1/2 Set Screw	2

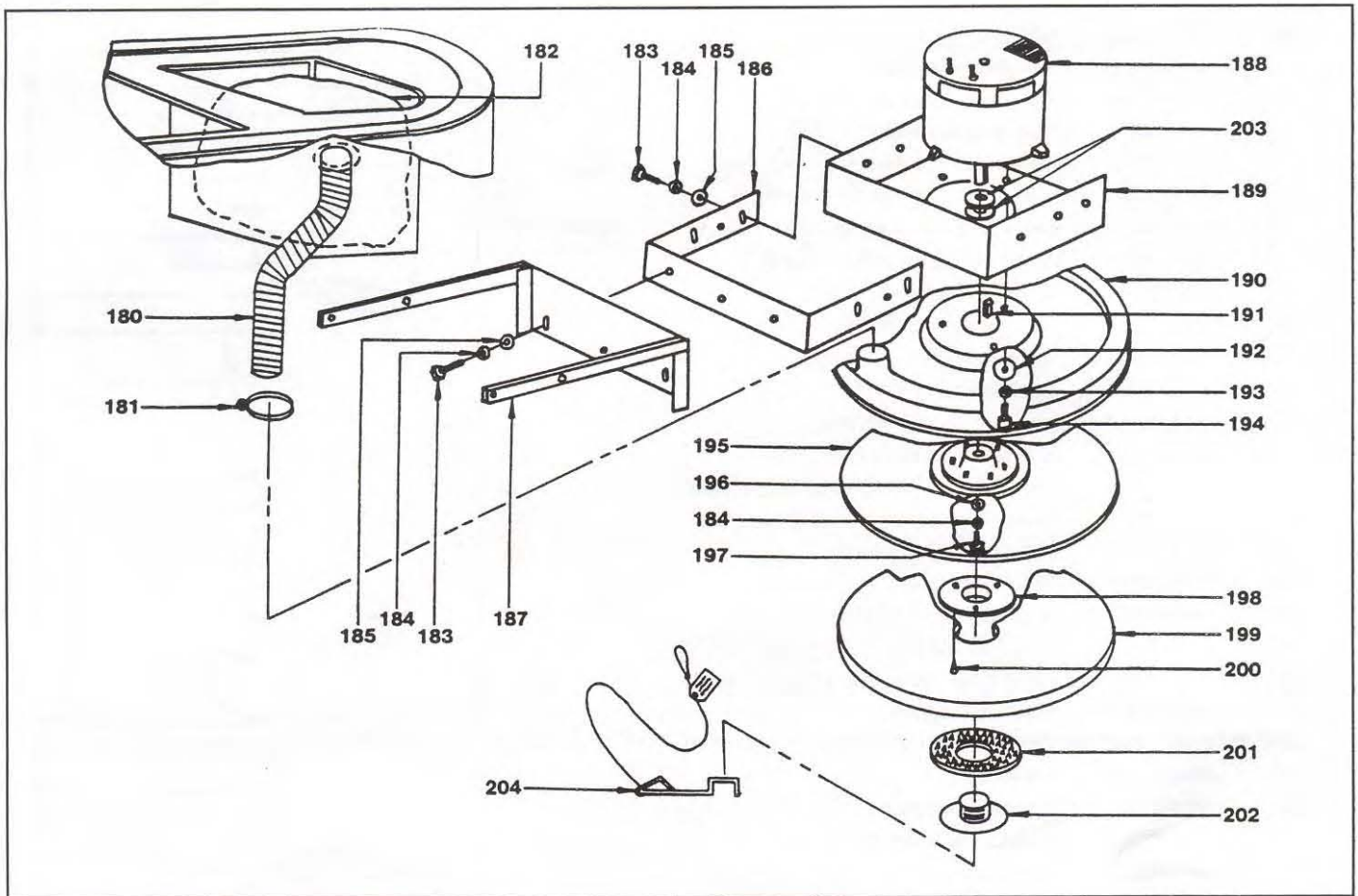

<u>ITEM NO.</u>	<u>PART NO.</u>	<u>DESCRIPTION</u>	<u>QUANTITY</u>
180	44-9-543-9	Hose w/Cuff	1
N/S	44-9-553-1	Hose Cuff - 2"	1
181	44-9-544-1	Hose Clamp	1
182	57-9-109-9	Bag (6-Pack)	1
N/S	44-9-006-1	Bag Shelf	1
183	-----	5/16-18 x 3/4 Hex Bolt	9
184	-----	5/16 Split Lock Washer	10
185	-----	5/16 Flat Washer	9
186	44-9-261-3	Fork	1
187	44-9-516-3	Pivot Weldment	1
188	44-9-001-9	Motor w/Boots - 3000BP	1
	44-9-100-9	Motor w/Boots - 2000BP	1
189	44-9-266-3	Motor Mount	1
190	44-9-555-9	Flexiwall Shield. w/Vac Pickup (Yellow)	1
	99-9-756-0	Velcro Loop Wear Strip	7 ft.
191	44-9-289-1	Motor Key	1
192	-----	1/4 Fender Washer	3
193	-----	1/4 Split Lock Washer	3
194	-----	1/4-20 x 1 Socket Head Cap Screw	3
195	44-9-552-9	Flexible Driver Assembly Balanced	1
196	52-9-354-1	3/8 Flat Washer	1
197	-----	5/16-24 x 7/8 Hex Bolt	1
198	52-9-769-1	Base for Pad Cup	1
199	28-9-004-1	20" Blonde Laminated Pad	1
200	-----	#10-16 x 1/2 Sheet Metal Screw	3
201	44-9-547-1	Pad Holding Ring Only .	1
202	44-9-548-9	Pad Holding Cup w/Ring	1
	(52-9-768-1)	Used S/N 18F99651 to S/N 25F03145 - 3000BP	1
		Used S/N 23F01394 to S/N 25F03145 - 2000BP	1
203	52-9-341 -1	Washer 3/4 x 1-1/4 x .060	2
204	44-9-549-1	Cup Wrench	1

TEM	PART NO.	DESCRIPTION
1	44-9-161 -1	Thru Bolt, 2 Req'd
2	-----	1/4 Star Lockwasher 2 Req'd.
3	-----	Plug (Not Available)
4	44-9-158-1	Rubber Boot, 2 Req'd.
5	44-9-162-1	Brass 5/16 Hex Nut Thin, 2 Req'd.
6	44-9-163-1	Brass 5/16-18 Hex Nut Thick, 1 Req'd.
7	-----	5/16 Split Lockwasher, 2 Req'd.
8	-----	5/16 Flat Washer, 2 Req'd.
9	44-9-164-1	Insulation Washer, 2 Req'd.
10	44-9-165-1	Insulation Spacer, 2 Req'd.
11	44-9-166-1	Top End Bell (Bell)
12	44-9-164-1	Insulation Washer, 2 Req'd.
13	-----	5/16 Flat Washer, 2 Req'd.
14	44-9-167-1	5/16-18 x 1-3/4 Hex Brass Bolt, 2 Req'd.
15	44-9-168-1	Brush Ring Assy.
16	44-9-169-1	Carbon Brush, 4 Req'd.
17	-----	10-32 x 3/8 Screw, Brass Binding Head, 4 Req'd.
18	44-9-170-1	Brush Spring, 4 Req'd.
19	-----	#10 Star Lockwasher, 2 Req'd.
20	-----	10-32 x 3/8 Screw Pan Head, 2 Req'd
21	44-9-171 -1	Frame w/Magnets
22	53-9-344-1	Thrust Washer, 2 Req'd.
23	50-9-204-1	Top Bearing
24	44-9-172-1	Armature w/Bearings - 2000BP
	44-9-320-1	Armature w/Bearings - 3000BP
25	44-9-173-1	Vent Fan
26	44-9-289-1	Key
27	44-9-084-1	Bottom Bearing
28	44-9-174-1	Bottom End Bell
29	44-9-175-1	Retaining Ring

NOTE: Those items not followed by quantity notations, require only 1.

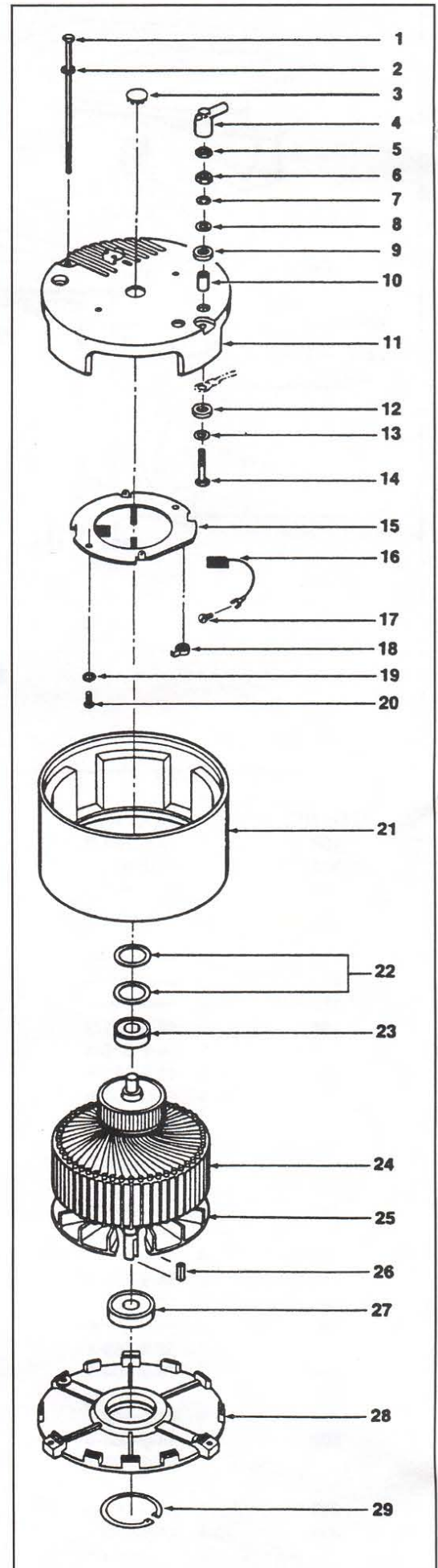

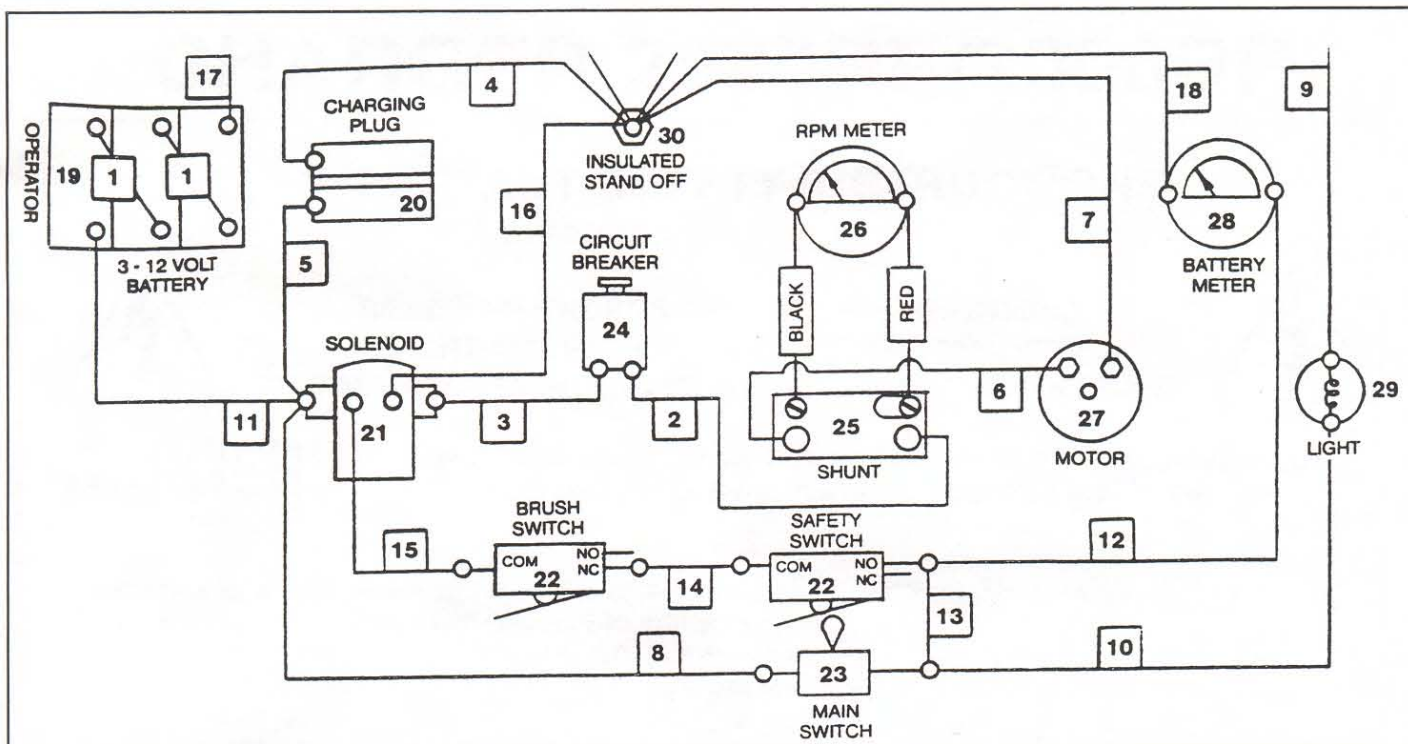

NOTE: Each wire lead is labeled with a number. That number is the item number shown on this diagram.

WIRING DIAGRAM

ITEM NO.	PART NO.	DESCRIPTION
1	44-9-111-1	Battery Cable, clamp type
	23-9-198-1	Battery Cable, eyelet type
2	44-9-115-1	Lead, Breaker to Shunt
3	44-9-120-1	Lead, Breaker to Solenoid
4	44-9-123-1	Negative Charger Lead
5	44-9-125-1	Positive Charger Lead
6	44-9-127-1	Lead, Shunt to Motor Positive
7	44-9-129-1	Lead, Stand Off to Motor Negative
8	44-9-131-1	Lead, Main Switch to Solenoid
9	44-9-136-1	Lead, Stand Off to Light
10	44-9-139-1	Lead, Light to Main Switch
11	44-9-141-1	Lead, Solenoid to Battery Positive, clamp type
	23-9-254-1	Lead, Solenoid to Battery Positive, eyelet type
12	44-9-144-1	Lead, Battery Meter to Safety Switch
13	44-9-148-1	Lead, Main Switch to Safety Switch
14	44-9-149-1	Lead, Brush Switch to Safety Switch
15	44-9-151-1	Lead, Brush Switch to Solenoid
16	44-9-153-1	Lead, Stand Off to Solenoid
17	44-9-154-1	Lead, Stand Off to Battery Negative, clamp type
	23-9-255-1	Lead, Stand Off to Battery Negative, eyelet type
18	44-9-155-1	Lead, Stand Off to Battery Meter
19	44-9-106-1	Battery, 12 Volt, 3 Req'd
20	44-9-190-1	Anderson Charger Plug Only
	44-9-160-1	Anderson Charger Plug w/Wires
21	44-9-101-1	Solenoid
22	44-9-107-1	Switch, 2 Req'd.
23	44-9-110-1	Toggle Switch
24	44-9-070-1	Circuit Breaker
25	44-9-103-1	Shunt
26	44-9-104-1	RPM Meter
27	44-9-105-1	Motor
28	44-9-105-1	Battery Meter
29	44-9-109-1	Light
30	44-9-056-1	Insulated Stand Off



THE NATIONAL SUPER SERVICE COMPANY

3115 FRENCHMENS ROAD, TOLEDO, OHIO 43607-2958

PHONE (419) 531-2121 • FAX (419) 531-3761