

PARTS LIST

ELECTRIC CHARGER 2500

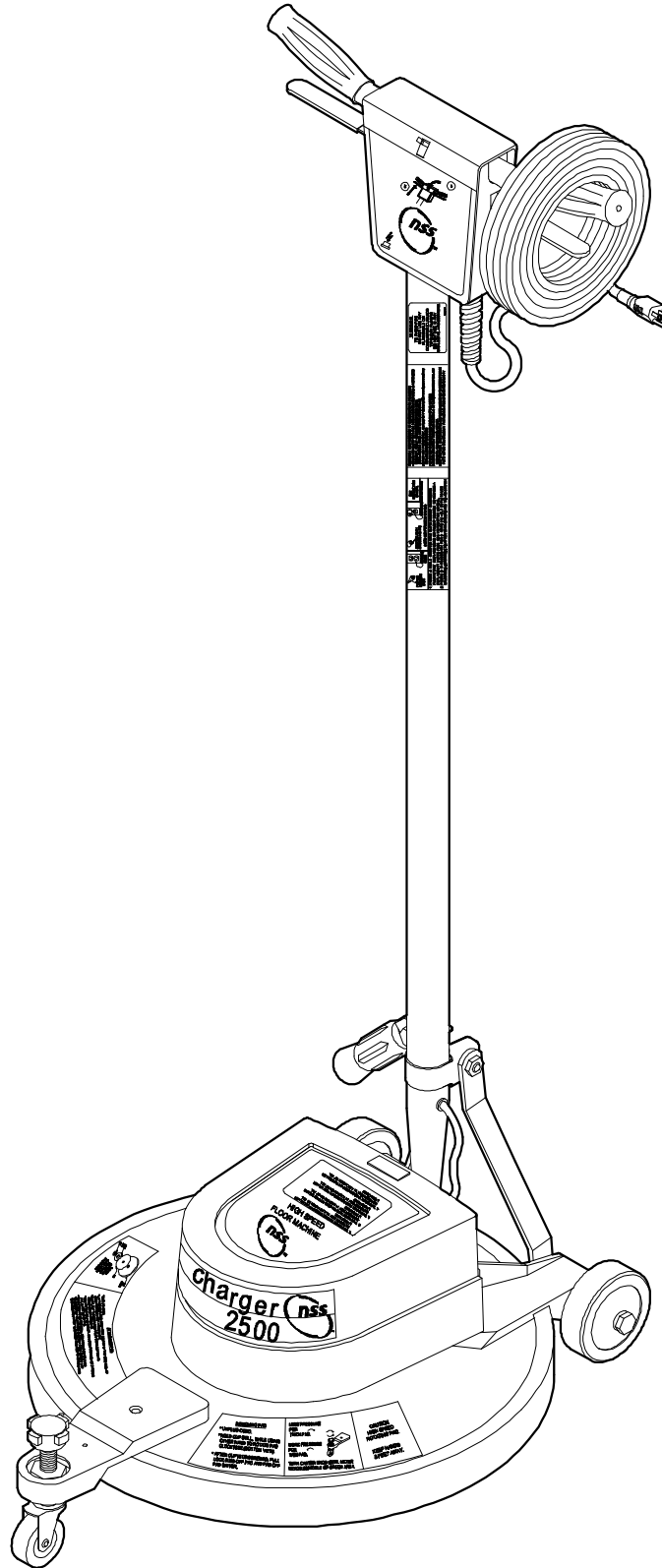

WIRE DIAGRAM

120 VOLT

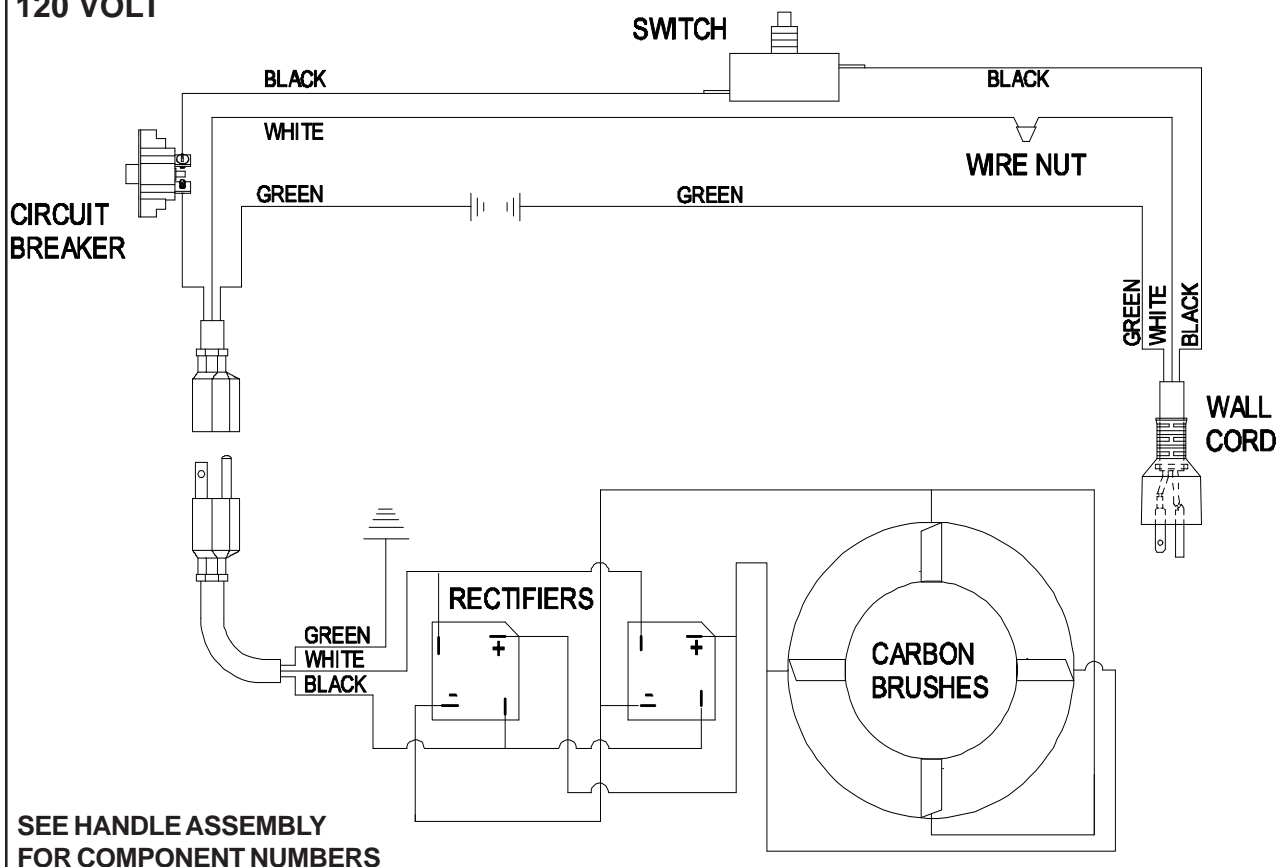

240 VOLT

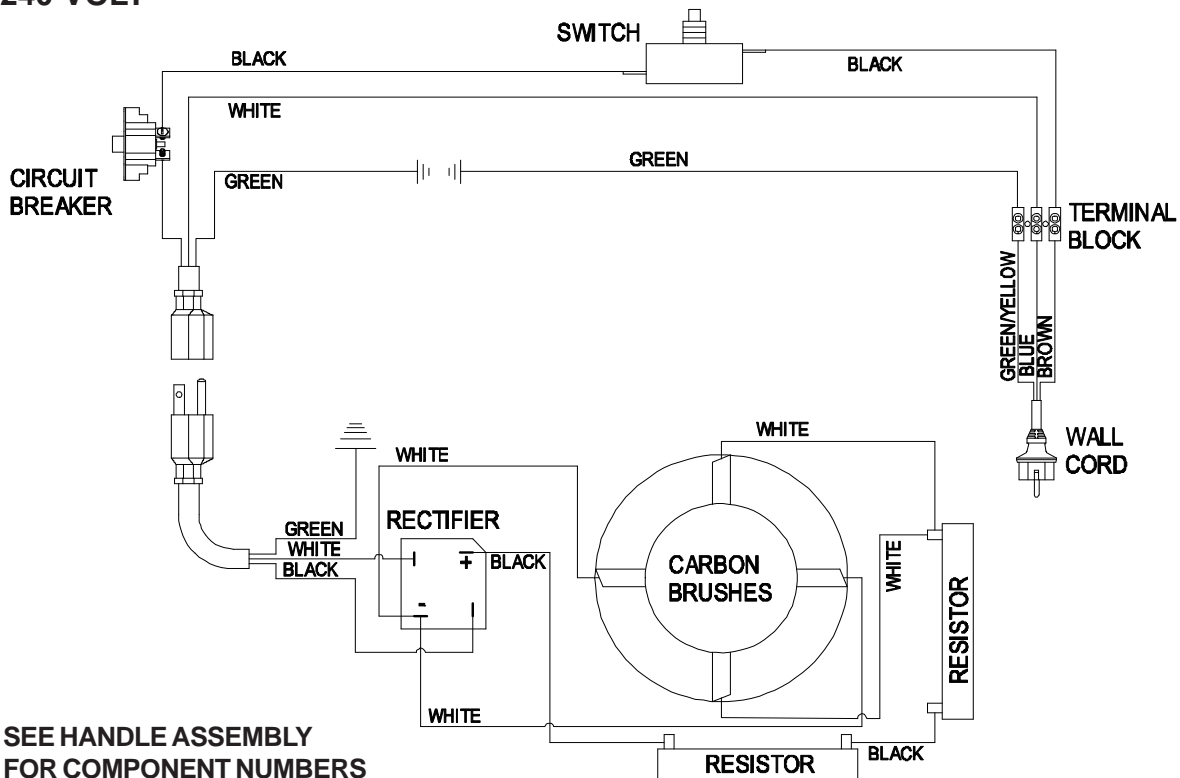

MOTOR ASSEMBLY

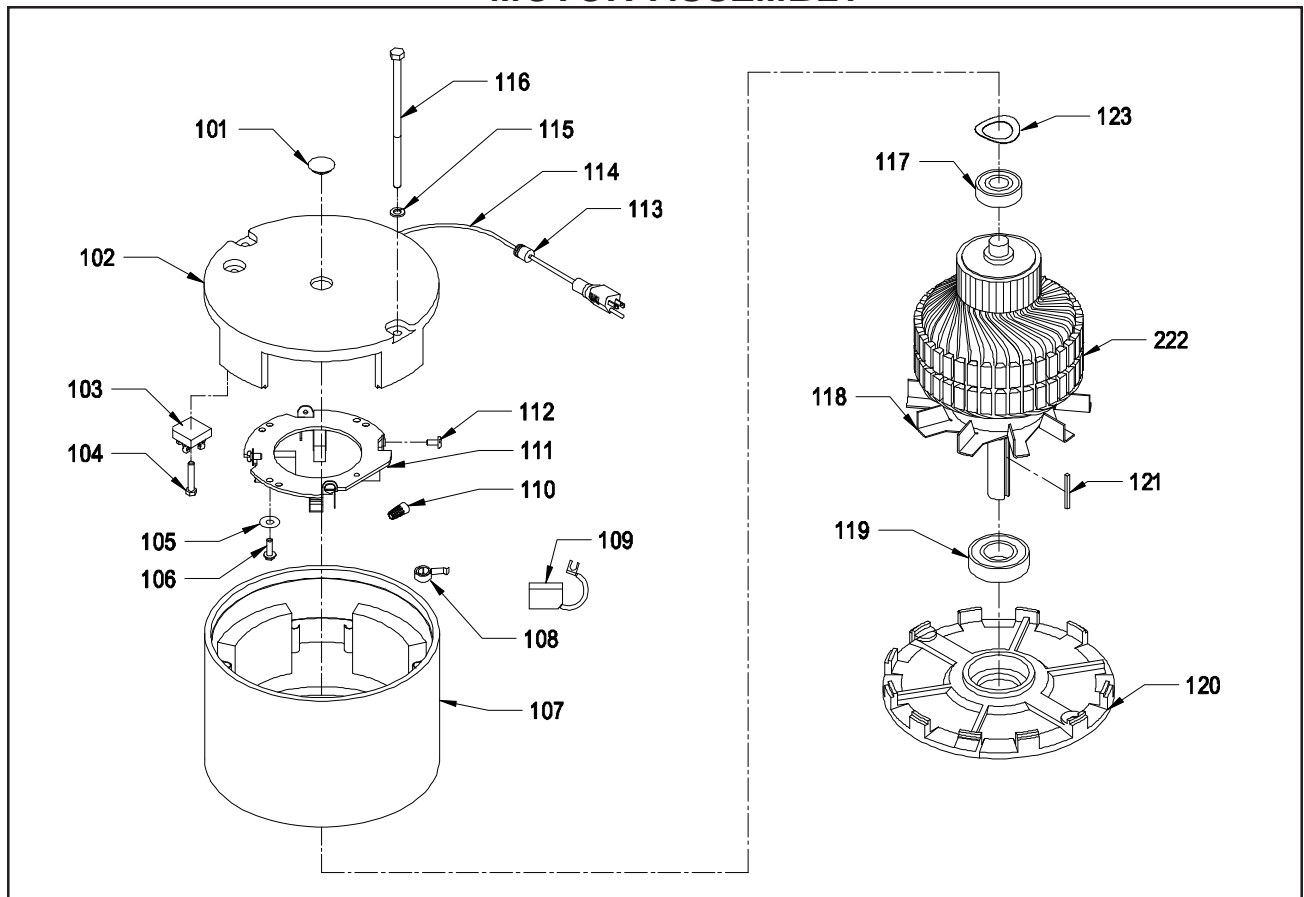

<u>ITEM</u>	<u>PART NO.</u>	<u>PART DESCRIPTION</u>	<u>QTY.</u>
	5298001	MOTOR - 115 VOLT	1
	5297581	MOTOR - 240 VOLT	1
101	-----	PLUG - NOT AVAILABLE	1
102	5294111	TOP END BELL	1
	5294401	TOP END BELL ASSEMBLY WITH PIGTAIL	1
103	5492741	RECTIFIER - 60 AMP - 120 AND 240 VOLT	2
104	9120260	8-32 X 3/4 ROUND HEAD PHILLIPS MACHINE SCREW	1
105	9120330	10 EXTERNAL STAR LOCK WASHER	2
106	9120771	10-32 X 5/8 PAN HEAD PHILLIPS MACHINE SCREW	2
107	5294121	FRAME WITH MAGNETS	1
108	5293881	BRUSH SPRING	4
109	5294051	CARBON BRUSHES	4
110	5390291	WIRE NUT	1
111	5490421	BRUSH RING ASSEMBLY WITH DUAL RECTIFIERS	1
112	9120560	10-24 X 1/4 BINDING HEAD SLOT MACHINE SCREW - BRASS	4
113	5293941	HEYCO STRAIN RELIEF	1
114	5990511	CORD	1
115	9120880	1/4 SPLIT LOCK WASHER	2
116	5492801	1/4-20 X 7 HEX WASHER HEAD THRU BOLT	2
117	5092041	TOP BEARING	1
118	4491731	VENT FAN	1
119	5293461	BOTTOM BEARING	1
120	5294141	BOTTOM END BELL	1
121	9120827	3/16 SQUARE X 1 LONG KEY - STEEL	1
122	5294131	ARMATURE AND VENT FAN ASSEMBLY - 120 VOLT	1
	5294741	ARMATURE AND VENT FAN ASSEMBLY - 240 VOLT	1
123	5293441	1 3/16 I.D. X 1 1/2 O.D. 2 WAVE SPRING WASHER	2

HANDLE ASSEMBLY

<u>ITEM</u>	<u>PART NO.</u>	<u>PART DESCRIPTION</u>	<u>QTY.</u>
	5297649	COMPLETE HANDLE ASSEMBLY - 75 FOOT CORD - 120 VOLT	1
	5296689	COMPLETE HANDLE ASSEMBLY - 75 FOOT SHUKO CORD - 240 VOLT	1
202	5391873	COVER - SWITCH BOX	1
203	5392421	DECAL - "SWITCH BOX WITH CIRCUIT BREAKER ICON"	1
204	0393511	LOCKOUT BRACKET	1
205	0393521	LOCK OUT	1
206	9120828	1/8 X 1 3/4 ROLL PIN	2
207	5390171	SWITCH LEVER SPRING	2
208	0393411	GRIP - SWITCH LEVER	2
209	0393401	SWITCH LEVER	1
210	9120100	6-32 X 1 ROUND HEAD PHILLIPS MACHINE SCREW	2
211	9120130	6 EXTERNAL STAR LOCK WASHER	2
212	5390211	SWITCH	1
213	5390361	SWITCH INSULATOR	1
214	5391321	WIRE NUT - ORANGE - 120 VOLT ONLY	1
215	0294031	# 8 RING TERMINAL	1
216	9120380	10-24 X 3/8 ROUND HEAD PHILLIPS MACHINE SCREW	1
217	9120320	10 SPLIT LOCK WASHER	1
218	0298981	# 10 RING TERMINAL 14-16 GAGE	1
219	5490441	INSULATION - BREAKER LEAD	1
220	9120430	10-24 X 3/4 ROUND HEAD PHILLIPS MACHINE SCREW	2
221	5294381	17 1/2 AMP CIRCUIT BREAKER - 120 VOLT	1
	5294581	8 AMP CIRCUIT BREAKER - 240 VOLT	1
222	9120320	10 SPLIT LOCK WASHER	2
223	9120360	10-24 HEX NUT WITH STAR LOCK WASHER	2
224	5490451	CIRCUIT BREAKER LEAD - 4"	1
225	9120200	8 SPLIT LOCK WASHER	1
226	9120223	8-32 X 1/4 PAN HEAD PHILLIPS MACHINE SCREW	1
227	5390511	FOAM PAD	1
228	5392401	DECAL - "WARNING - FIRE"	1
229	0190901	DECAL - "WARNING" - 120 VOLT ONLY	1
	0190921	DECAL - "ICON ADAPTOR" - 240 VOLT ONLY	1
230	0190911	DECAL - "GROUNDING" - 120 VOLT ONLY	1
231	5391891	HANDLE	1
232	5091636	CORD HOOK CLAMP	1
233	9120880	1/4 SPLIT LOCK WASHER	2
234	9121010	1/4-20 X 3/4 TRUSS HEAD PHILLIPS MACHINE SCREW	2
235	5090441	NYLON BUSHING	2
236	5490861	CORD - HANDLE	1
237	5293131	GROMMET	1
238	5293791	CORD - 75 FEET - 14-3 - 120 VOLT	1
	0299671	SHUKO CORD - 75 FEET - 16-3 - 240 VOLT	1
	5091569	CORD - 50 FEET - 14-3 - 120 VOLT - OPTIONAL	1
239	5091682	CORD HOOK	1
240	9120080	6-32 X 3/4 ROUND HEAD PHILLIPS MACHINE SCREW - 240 VOLT ONLY	1
241	5391931	TERMINAL BLOCK - 240 VOLT ONLY	1
242	5391921	WIRE - GROUND - 240 VOLT ONLY	1
243	5391911	WIRE - DEAD MAN - 240 VOLT ONLY	1
244	5091671	STRAIN RELIEF - 120 VOLT	1
	0299531	STRAIN RELIEF - 240 VOLT	1
245	5390261	STRAIN RELIEF NUT - 120 VOLT	3
	0891131	PLASTIC STRAIN RELIEF NUT - 240 VOLT	1
246	5092371	STRAIN RELIEF CORD CLAMP - 120 VOLT	1
	0299661	STRAIN RELIEF CORD CLAMP - 240 VOLT	1
247	5091656	7/8 I.D. X 1 3/8 O.D. X .112 THICK FLAT WASHER	1
248	5091661	CORD CLAMP	1

HANDLE ASSEMBLY

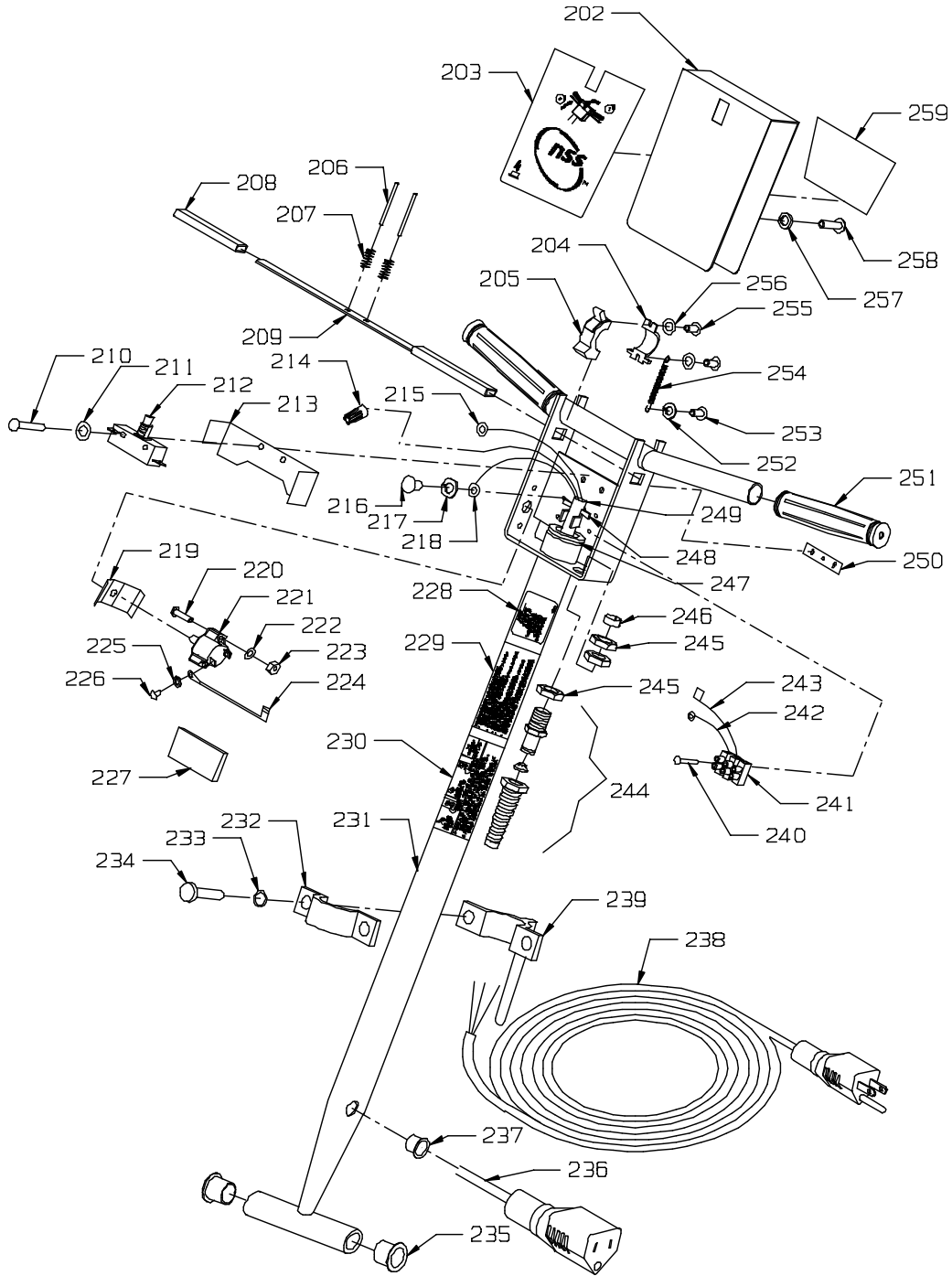

249	8791070	3/8 I.D. X 1/2 O.D. VINYL HOSE	4'
250	9120025	6-32 DOUBLE HOLE SWITCH SPEED NUT	1
251	5491211	HANDLE GRIP	2
252	9120320	10 SPLIT LOCK WASHER	1
253	9120380	10-24 X 3/8 ROUND HEAD PHILLIPS MACHINE SCREW	1
254	0393381	SPRING	1
255	0393881	M3 X .05 X 8mm PAN HEAD PHILLIPS THREAD CUTTING SCREW	2
256	0393841	M3 EXTERNAL STAR LOCK WASHER	2
257	9120320	10 SPLIT LOCK WASHER	2
258	9120430	10-24 X 3/4 ROUND HEAD PHILLIPS MACHINE SCREW	2
259	5392461	DECAL - "OPERATION"	1

BASE ASSEMBLY - UPPER

ITEM	PART NO.	PART DESCRIPTION	QTY.
301	5297569	MOTOR COVER ASSEMBLY - INCLUDES:	1
	5297561	MOTOR COVER	1
302	5296401	DECAL KIT - "TOP MOTOR"	1
303	8891130	GASKET 1 X 1/8 - NEOPRENE	1
304	5296401	DECAL KIT - "FRONT STRIP"	1
305	9120740	10-32 X 3/8 TRUSS HEAD PHILLIPS MACHINE SCREW	3
306	5294706	COVER STAND OFF	1
307	5298001	MOTOR - 120 VOLT - 1 1/2 H.P.	1
	5297581	MOTOR - 240 VOLT - 1 1/2 H.P.	1
308	5091691	RUBBER PAD - 1 IN FRONT - 2 ON EACH SIDE IN THE BACK	5
309	5296401	DECAL KIT - "ATTACHING PAD"	1
310	5296619	CASTER TRIM ASSEMBLY - INCLUDES:	1
	5296081	CASTER TRIM	1
311	9121680	5/16-18 X 1 HEX BOLT	2
312	9120380	10-24 X 3/8 ROUND HEAD PHILLIPS MACHINE SCREW	2
313	9120495	10 INTERNAL STAR LOCK WASHER	2
314	5296542	KNOB	1
315	9120850	1/4-20 X 5/16 SET SCREW KNURL POINT	1
316	5296573	CASTER BRACKET	1
317	5297826	CASTER STEM	1
318	9121967	7/16 EXTERNAL STAR LOCK WASHER	1
319	5296031	CASTER	1
320	9121430	5/16-18 HEX NUT WITH NY-LOK INSERT - THIN	2
321	5297513	BASE - SKIRT	1
322	9120850	1/4-20 X 5/16 SET SCREW - KNURL POINT	1
323	5296401	DECAL KIT - "REMOVING PAD"	1
324	9120827	3/16 SQUARE X 1 LONG KEY - STEEL	1
325	9121680	5/16-18 X 1 HEX BOLT	1
326	5390043	TUBE CLAMP	1
327	5390026	HANDLE BRACE	2
328	9122140	3/8-16 HEX NUT WITH NY-LOK INSERT	2
329	5390826	TUBE CLAMP SHOE	1
329	5391891	HANDLE	1
331	5390201	RUBBER TUBING	1
332	0393141	FLATTENED CLAMP BOLT	1
333	0393131	SLOTTED WASHER	1
334	9121420	5/16-18 HEX NUT	1
335	0393121	CLAMP LEVER	1
336	0393321	HANDLE GRIP	1
337	5297841	AMP METER WITH HARDWARE - 120 VOLT	1
	5297851	AMP METER WITH HARDWARE - 240 VOLT	1
338	9120210	8-32 X 1/4 TRUSS HEAD MACHINE SCREW	4

BASE ASSEMBLY - UPPER

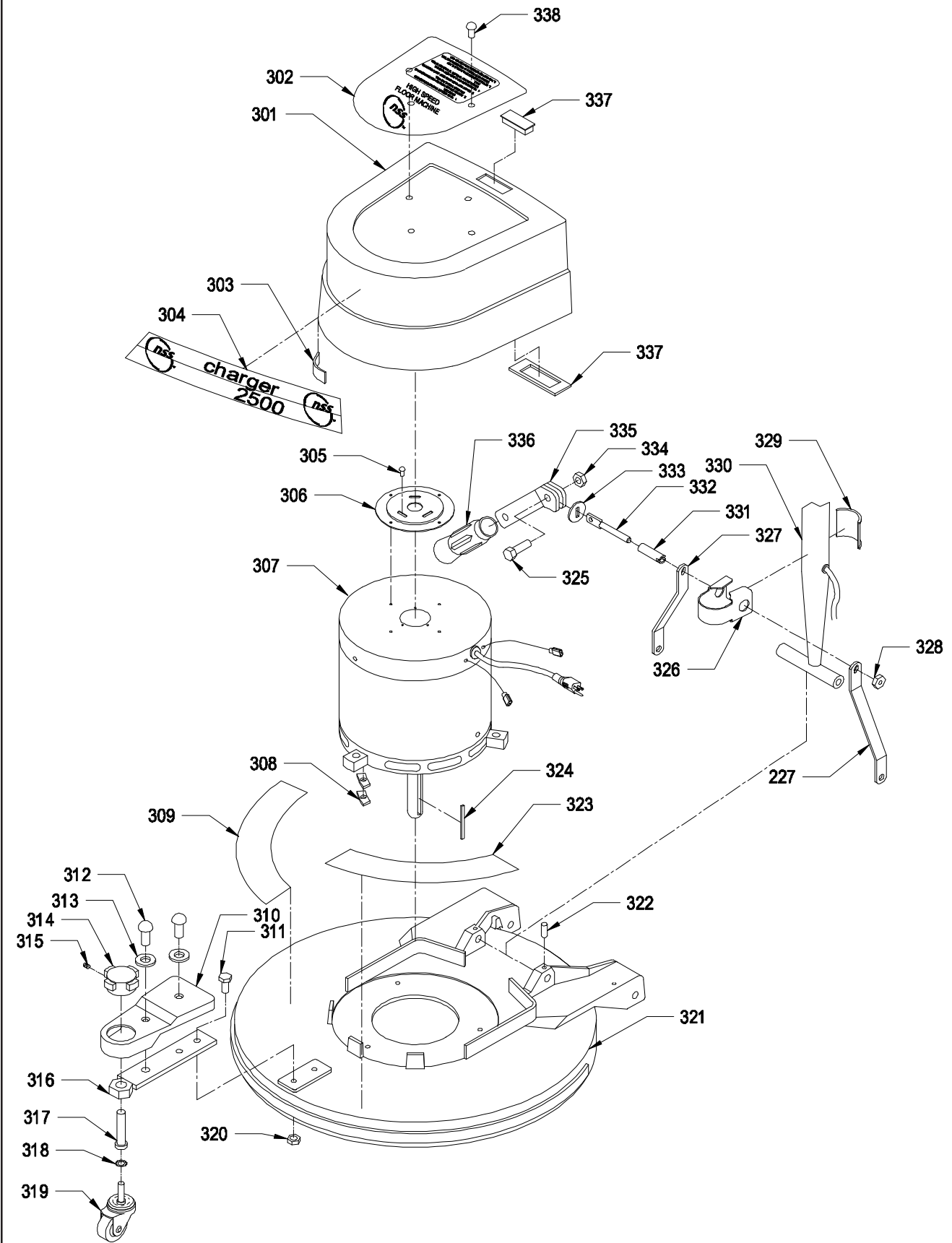

BASE ASSEMBLY - LOWER

ITEM	PART NO.	PART DESCRIPTION	QTY.
401	5297513	BASE - SKIRT	1
402	5296619	CASTER TRIM ASSEMBLY - SEE PRIOR PAGE FOR COMPONENT PARTS	1
403	9120950	1/4 X 1 1/4 FENDER WASHER	3
404	9120880	1/4 SPLIT LOCK WASHER	3
405	9121050	1/4-20 X 1 1/4 SOCKET HEAD CAP SCREW	3
406	5294248	FLEXABLE PAD DRIVER ASSEMBLY	1
407	9123105	3/4 I.D. X 1 1/4 O.D. X .071/.082 THICK FLAT WASHER (11 GAGE)	2
408	9121985	13/32 I.D. X 1 O.D. X .12 THICK FLAT WASHER (11 GAGE)	1
409	-----	PAD - SEE ACCESSORIES PAGE FOR OPTIONS	1
410	5990731	SPRING CLIP PAD HOLDER SET - INCLUDES:	1
411	9120140	#6 X 5/8 PAN HEAD SHEET METAL SCREW	3
412	9121490	5/16-24 X 7/8 HEX BOLT	1
413	9121985	13/32 I.D. X 1 O.D. X .12 THICK FLAT WASHER (11 GAGE)	1
414	5297619	SHROUD ASSEMBLY - INCLUDES:	1
	5297611	SKIRT	1
	9997560	VELCRO LOOP	6 FT
	8891070	CLOSED CELL NEOPRENE 3/8 X 3/8	1
415	5297783	STEEL RING	1
416	5091281	BUMPER	1
417	9120850	1/4-20 X 5/16 SET SCREW - KNURL POINT	2
418	5297556	PIVOT BAR	1
419	9122715	1/2-20 X 5 1/2 HEX BOLT	2
420	9122450	17/32 I.D. X 1 16 O.D. X .074/.121 THICK FLAT WASHER (1/2)	2
421	5296401	DECAL KIT - "WHEEL COVER"	1
422	5092591	WHEEL - 5" WITH PLASTIC BEARING	2
423	5390811	1/2 I.D. X 1 O.D. X .07 THICK FLAT WASHER - NYLATRON	2
424	9122705	1/2 I.D. X 3/4 O.D. X .01 THICK - 1 WAVE SPRING WASHER (1/2)	2
425	9122705	1/2 I.D. X 3/4 O.D. X .01 THICK - 1 WAVE SPRING WASHER (1/2)	2
426	5390026	HANDLE BRACE	2
427	5390811	1/2 I.D. X 1 O.D. X .07 THICK FLAT WASHER - NYLATRON	2
428	9122690	1/2-20 HEX NUT WITH NY-LOK INSERT - THIN	2
429	9120850	1/4-20 X 5/16 SET SCREW - KNURL POINT	2

BASE ASSEMBLY - LOWER

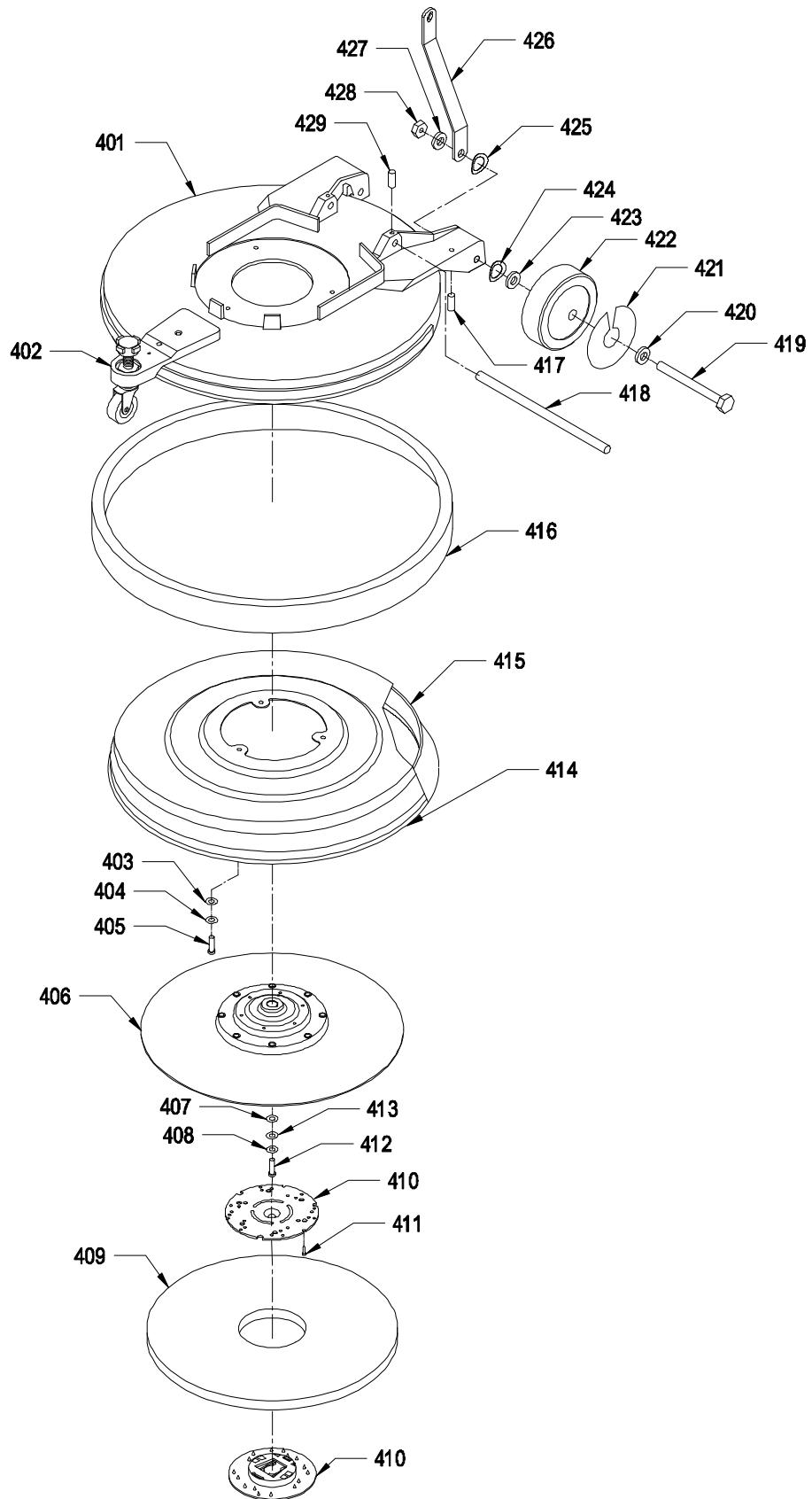

ACCESSORIES



<u>PART NO.</u>	<u>PART DESCRIPTION</u>
NOTE:	ALL PADS COME 5 (FIVE) PADS PER CASE
7992051	20" LITE BLUE POLISH / BURNISH PAD - FOR SOFT FINISH
7992061	20" LITE HAIR BURNISH PAD - FOR ALL FINISHES
7992081	20" ULTRA HAIR HARD FINISH PAD - FOR HARD FINISH
7992091	20" ULTIMATE HAIR PAD - HARD FINISH AGGRESSIVE BURNISHING
7992021	20" GREEN SCRUB PAD - HEAVY FINISH REMOVAL
7992001	20" BLACK STRIP PAD - REMOVES FINISH COMPLETELY
7992011	20" BROWN STRIP PAD - REMOVES FINISH COMPLETELY

NOTES



NSS® Enterprises, Inc.

3115 Frenchmens Road, Toledo, Ohio 43607
PHONE (419) 531-2121 FAX (419) 531-3761

® **NSS® Enterprises, Inc. European Distribution Centre**
Unit II, Pinfold Trading Estate * 55 Nottingham Road
STAPLEFORD, NOTTINGHAM NG9 8AD ENGLAND U.K.
PHONE: (44) 0115 939 1568 * FAX: (44) 0115 949 0615