Attention Service Manager/Parts Department

Bulletin Level: 2

Specific Warranty Coverage: Standard Warranty Coverage

Subject: New upper isolator – **Refer to TSBCL2010-12 for related Boost Deck & Isolator Improvements.**

Models Affected: Focus II Boost L20 (all models)

Parts List Form Number(s) Affected: PL9097066000

ECO#: A-05612

Informational Bulletin: N/A

Issue: Premature isolator failure during assembly or at low hours

Cause: Inadequate bond between rubber body and stud plate

Corrective Action: Factory: Effective 6/17/10 with SN 8000025674, Isolator p/n 56380223 was replaced with p/n 56380280 which had a larger stud plate (See Figure 1 below). As a further enhancement on 7/12/10 and with SN 8000027901, isolator p/n 56380272 made from a neoprene vs. rubber material replaced 56380280.

Field: If you experience a premature isolator failure, replace the older style Isolator with p/n 56380280 or 56380272.

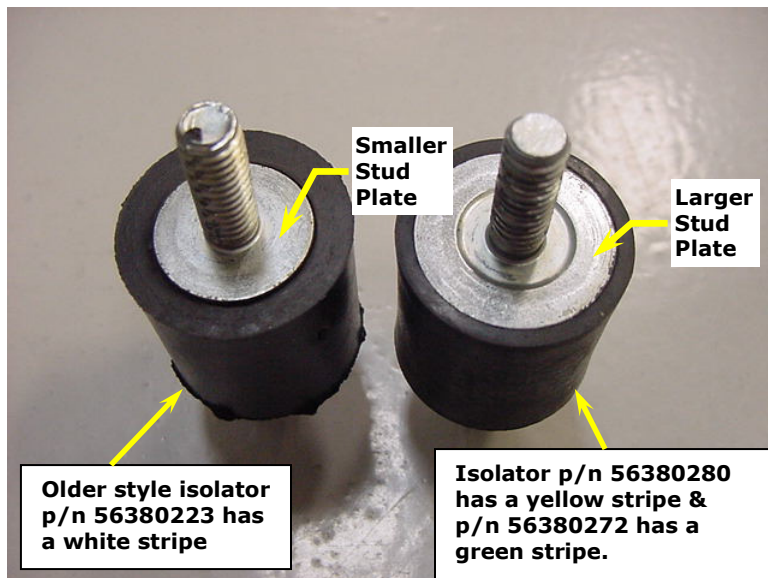

Caution: When installing the new Isolators, be careful not to overtighten the Isolators or nuts. Install as follows:

1. Apply Loctite to the bottom threads on the Isolator and hand-tighten into the deck.
2. Apply Loctite to the nut on the Isolator top threads and torque the nut to 8-10 in-lbs / 10.8-13.5 Nm.

* **Technical Service Bulletin Levels:**

Level 1: These Bulletins contain general information and are without specific warranty coverage.

Level 2: These Bulletins describe continuous quality improvements that are made to products. Specific warranty coverage may apply and if so is noted in the Bulletin.

Level 3: These Bulletins describe a quality problem that has been determined to require a mandatory update to the product. Specific warranty coverage is as noted in Bulletin.

Attention Service Manager/Parts Department

Bulletin Level: 2*

Specific Warranty Coverage: Standard Warranty Coverage
with 1 year travel

(vs. 30 day standard)

Subject: BOOST Flex Plate, Bearing Shield & Isolator Replacement – **Revised to reflect change in 20" Upper Isolator and Nut, and further improvements to the Flex Plate mounting. Refer to TSBCL2010-21**

Models Affected: BOOST 28
BOOST 32 (05312K, 05313K)
Focus BOOST Rider (00344K)
Focus II BOOST L20 (05370A-S)
Focus II MID-SIZE BOOST 28 & 32

Parts List Form Number(s) Affected: PL71071A, PL71271A, PL71171A, PL9097066000, PL71483A

ECO#: A-05077, A-05249, A-05257, A-05349, A-05448, A-05476

Informational Bulletin: N/A

Issues:

1. Pad driver material delaminating from the flex plate
2. Bearing shield and / or eccentric bearing failure
3. Scrub deck isolator failure
4. Flex plate wears or mounting screws loosen

Cause:

1. Velcro-type pad driver failure. When exposed to certain chemicals, the adhesive holding the Velcro-type pad driver material to the flex plate could weaken and potentially delaminate.
2. Shortened bearing life:
 - a. The bearing shield can come loose, exposing the bearing to water. This exposure can eventually result in moisture working its way into the bearing, causing bearing wear or even eventually causing the bearing to seize.
 - b. The eccentric bearing can loosen due to variations in bearing bore diameter and/or retainer plate screws coming loose, resulting in the bearing potentially spinning in the driver plate.
3. Isolator wear or excessive deck vibration:
 - a. Upper and lower isolators can incorrectly be interchanged and subsequently installed in the wrong positions causing reduced performance.
 - b. If excessive torque is applied during isolator installation the isolators can be twisted and effectively pre-loaded, which can result in diminished performance and the potential for premature wear and / or failure.
4. Vibration results in wear between the flex plate and screw head.

* **Technical Service Bulletin Levels:**

Level 1: These Bulletins contain general information and are without specific warranty coverage.

Level 2: These Bulletins describe continuous quality improvements that are made to products. Specific warranty coverage may apply and if so is noted in the Bulletin.

Level 3: These Bulletins describe a quality problem that has been determined to require a mandatory update to the product. Specific warranty coverage is as noted in Bulletin.

Corrective Action:

Factory (Effective with the machine serial numbers listed in the table below):

1. A new flex plate assembly was implemented with the following improvements:
 - a. Switched to a nylon pad driver material with "harpoon" style barbs (eliminated the fabric Velcro-type material)
 - b. Mechanically securing the pad driver material via rivets
2. The bearing assembly was updated with the following changes:
 - a. Using an improved molded plastic bearing shield to deflect water away from the bearing. The new bearing shield uses a significantly more durable material and a tighter assembly fit for better retention and durability than the previous version.
 - b. The eccentric bearing bore in the driver plate was changed from being a molded-in feature to being machined to allow tighter tolerance control, and Loctite® was added to the retaining screws.
3. Switched to improved isolators and an updated assembly process:
 - a. Tightened component tolerances.
 - b. Incorporated color coding to clearly identify upper and lower isolators.
 - c. Implemented an identification stripe to aid in correctly positioning the isolators and to assist in visually identifying (and preventing) over-torqued isolators.
 - d. Adjusted assembly process to reduced torque specification to prevent isolator twisting.
 - e. Locknut, p/n 920110, was replaced with a flange nut, p/n 81211A, to further reduce the potential of twisting the isolator during installation (see Figure 19). The upper isolator on the 20" machines was revised. Refer to TSBCL2010-21 for details.

The improvements noted in items **a** through **d** above were implemented effective with the following serial numbers:

Machine	Serial Number
CR28 BOOST Rider	100500963
Focus Rider 32" BOOST	3000022848
20" Focus II BOOST L20	8000023707
28" Focus II Midsize BOOST	3000025770
32" Focus II Midsize BOOST	3000025783

The improvements noted in item **e** above were implemented per TSBCL2010-21.

4. The flex plate was redesigned to utilize a bushing and socket head screw vs. a tapered flat head screw to secure the flex plate to the driver plate. This change was implemented on all models as noted in the table below and on all kits effective 6/23/10.

Size	Serial Number	Effective Date
20"	8000025930	6/21/10
28"	3000032657	6/22/10
32"	3000030245	6/23/10

Field:

1. If premature separation between the Velcro-type pad driver material and flex plate is observed on machines with serial numbers prior to those listed in the above table, replace the flex plate with the flex plate kits noted on page 7.

NOTE! The new flex plates are not compatible with the current BOOST brushes. If premature separation occurs in applications using these brushes, the flex plate will need to be replaced with the original P/N's.

2. If premature bearing shield, isolator, or eccentric bearing wear is observed on machines with serial numbers prior to those listed in the above table, replace the bearing shield, bearing and isolators with the kits noted on page 7.

NOTE! For machines using brushes, individual P/N's (instead of the full replacement kit P/N's) will need to be ordered for the new bearing shield, isolators, and eccentric bearing.

3. If premature wear occurs at the flex plate mounting, replace with the new plate and hardware.

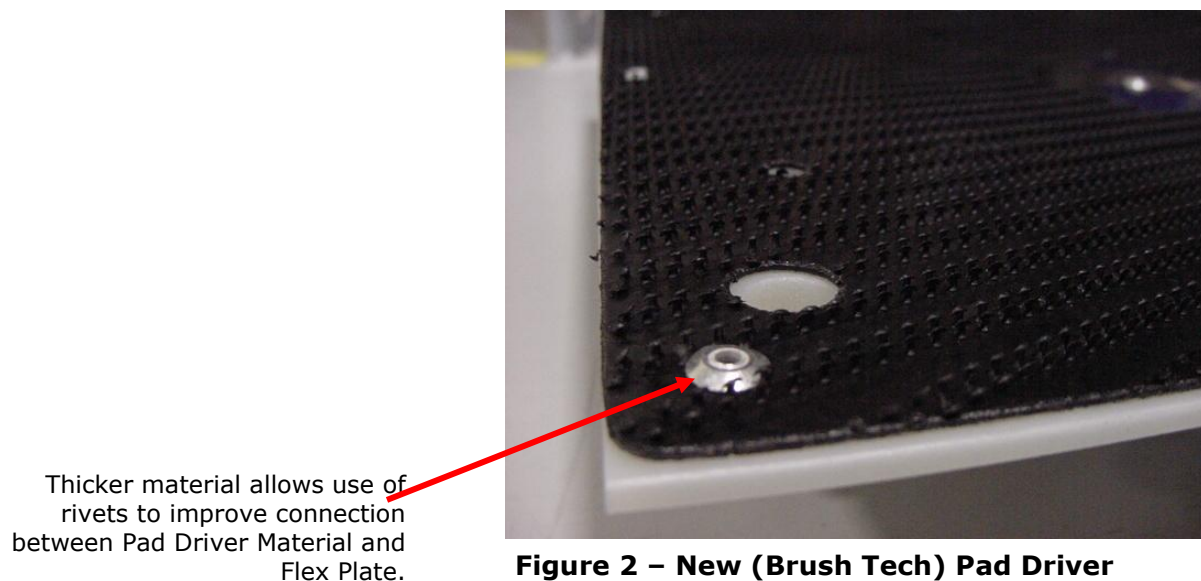
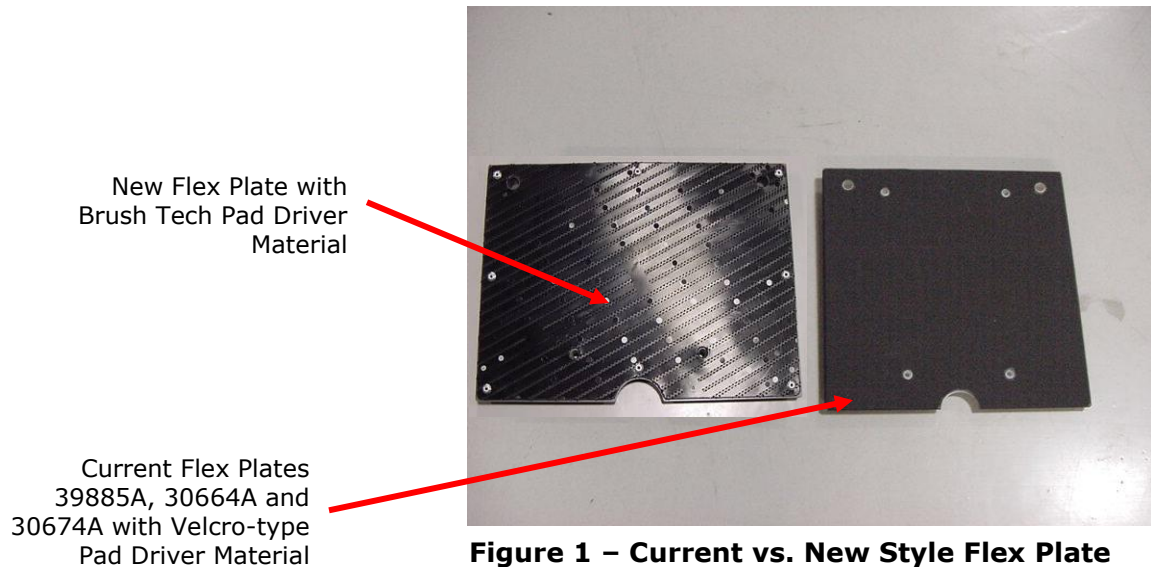

Under certain conditions the adhesive on the new Flex Plate may break down and release along the edges, but this does not affect functionality. The additional rivet fastening maintains integrity and keeps the Pad Driver Material secured to the Flex Plate.

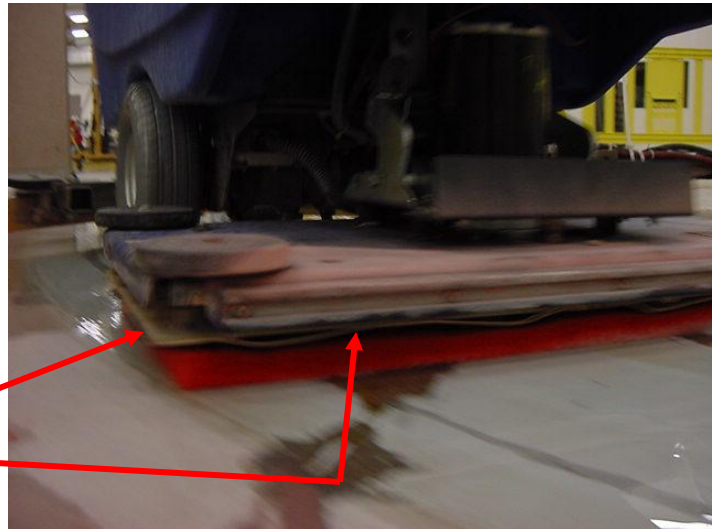

Figure 3 – Adhesive on New Flex Plate

New Pad Driver Material has molded-in hooks to improve pad retention.

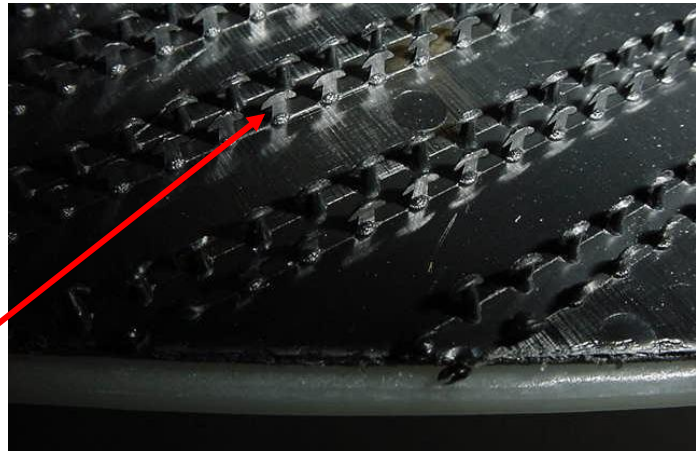

Figure 4 – Molded-in Hooks in New Driver Material

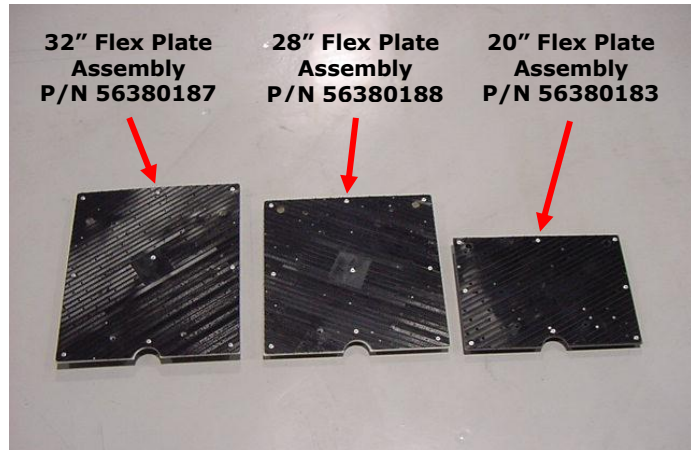

Figure 5 – New 32", 28" and 20" Flex Plates

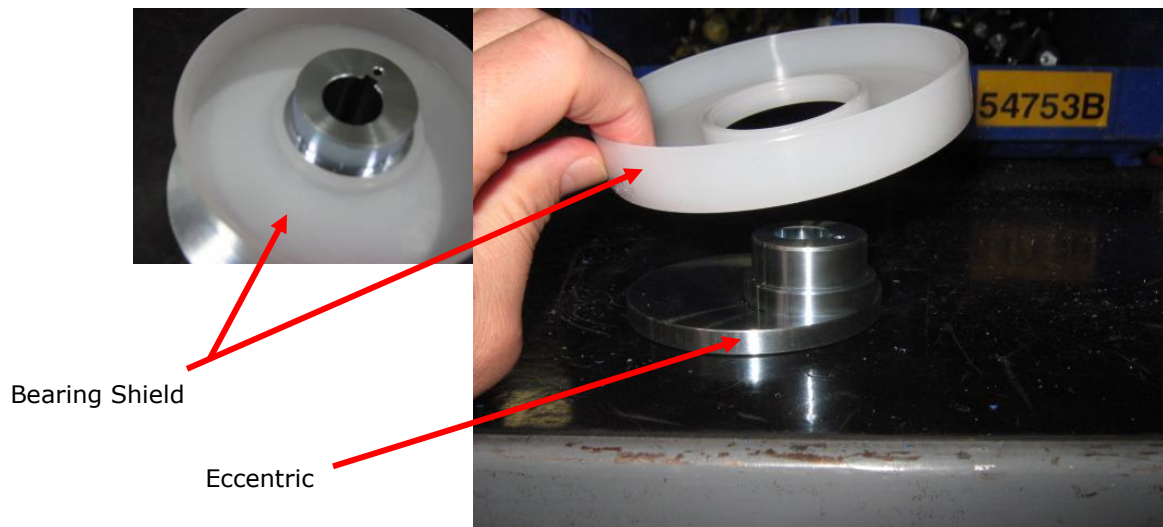

Figure 6 – Bearing Shield Assembly



Figure 7 – Improved Bearing Shield, P/N 56380192

The new Isolators have stripes to aide in preventing over-tightening.

- Isolator 56380190 has a light blue stripe and replaces 53730A.
- Isolator 56380193 has a red stripe and replaces 54753B.
- Isolator 56380280 has a green stripe and replaces 56380223. Refer to TSBCL2010-21 for additional details.

New Isolators with visible vertical stripes to prevent over-tightening

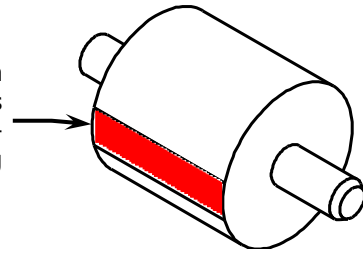

Figure 8 – New Isolator

Note: Isolators must not be over-tightened.
Maximum Torque: 8 to 10 ft-lbs.

Note: Isolators are no longer sold individually.

The following kits are now available:

- 20" Isolator Kit, P/N 56380236
- 28"/32" Isolator Kit, P/N 56380235

New Flex Plate Mounting Hardware:

See Figure 9. Socket Head Screws have replaced the tapered Flat Head Screws securing the Flex Plate to the Driver Plate. Through Holes with Bushings have replaced the Countersunk Holes in the Flex Plate.

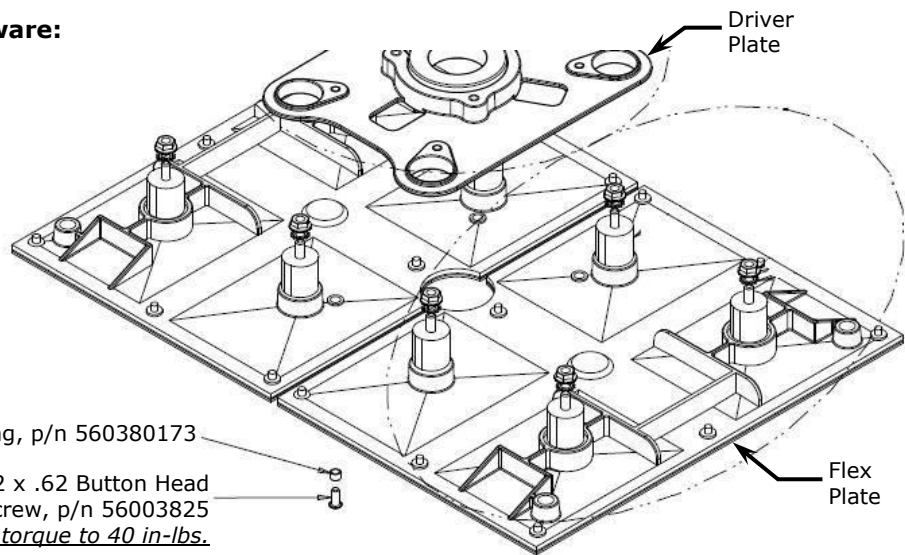

Note: Use Loctite® 242 and torque to 40 in-lbs.

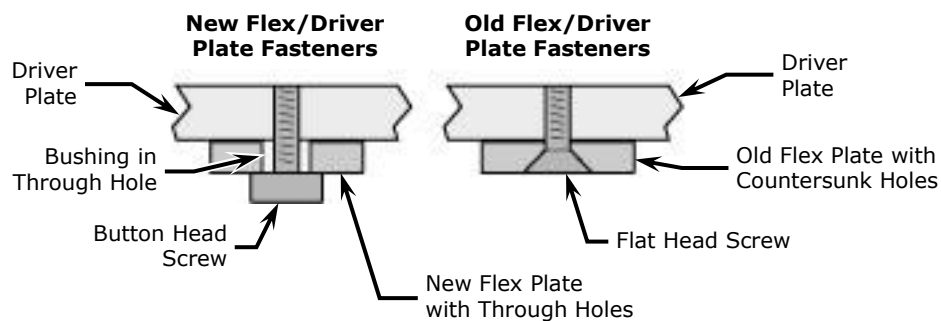

Figure 9 – New Flex Plate Mounting Hardware

Note: If you order a new Flex Plate, you'll need to order new fasteners:

- Flex Plate Bushing, p/n 560380173
- #10-32 x .62 Button Head Socket Screw, SS, p/n 56003825

Flex Plate Kit Assembly Instructions:

The following kits are now available:

- 20" Flex Plate Assembly Kit, P/N 56380209
- 28" Flex Plate Assembly Kit, P/N 56380210
- 32" Flex Plate Assembly Kit, P/N 56380211

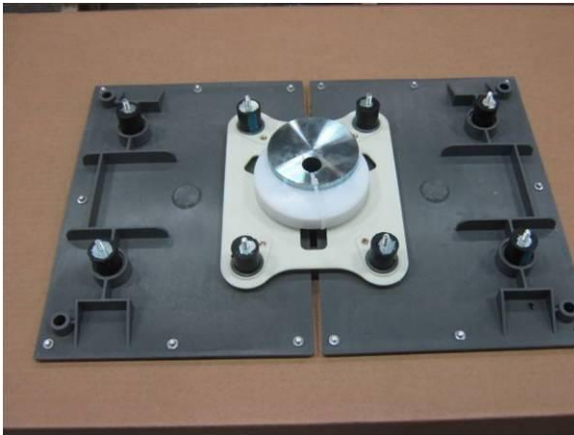

Figure 10a – 20" Flex Plate Assembly Kit



Figure 10b – 32" Flex Plate Assembly Kit (28" Kit similar)

IMPORTANT!

When assembling the deck, it is important to follow the supplemental steps below where applicable as well as the installation instructions contained within each kit.

Steps 1, 2, & 4 can be skipped if installing the pre-assembled kits listed above.

Step 1 Install the Pad Driver Plate over the isolators.

IMPORTANT!
The Pad Driver Plate must be fully seated and flush with the surface. Do not use the attachment screws to pull it into place.

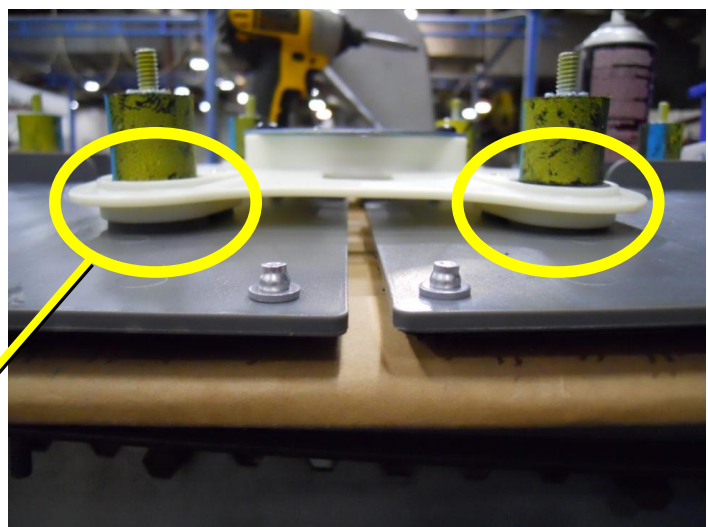

Figure 11 – Pad Driver Plate installed over Isolators

Step 2 Secure the Pad Driver Plate to the Flex Plate(s) with screws.

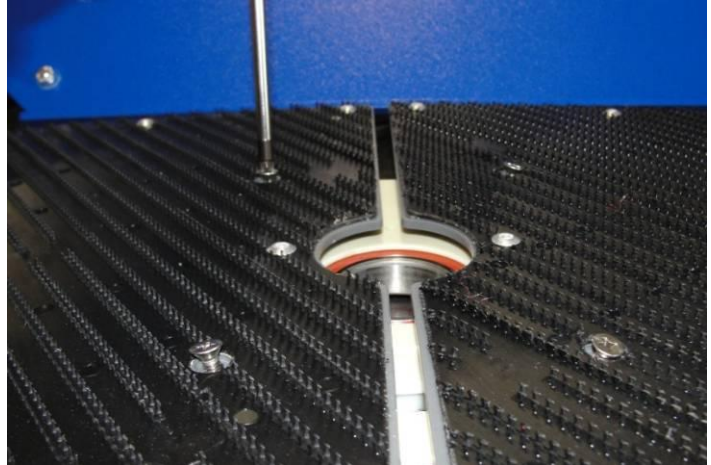

Figure 12 – Fastening the Flex Plate(s) to the Driver Plate

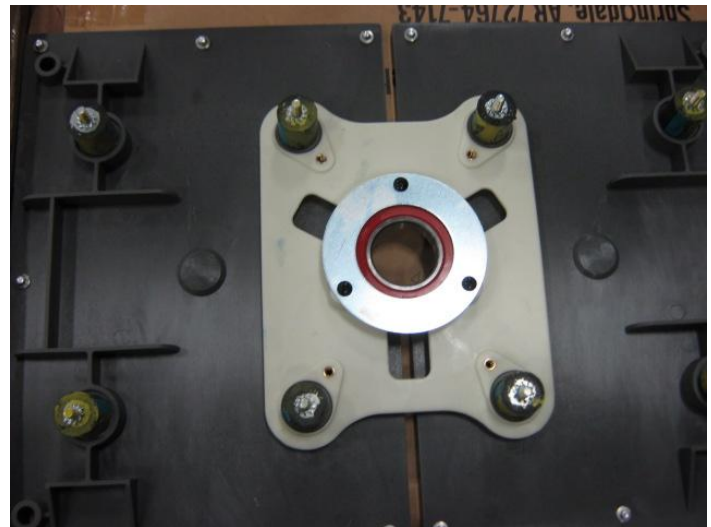

Figure 13 – Assembled Flex Plate Assembly

Step 3 Install Star Lock Washers over the Isolators and apply Loctite® to the threads.

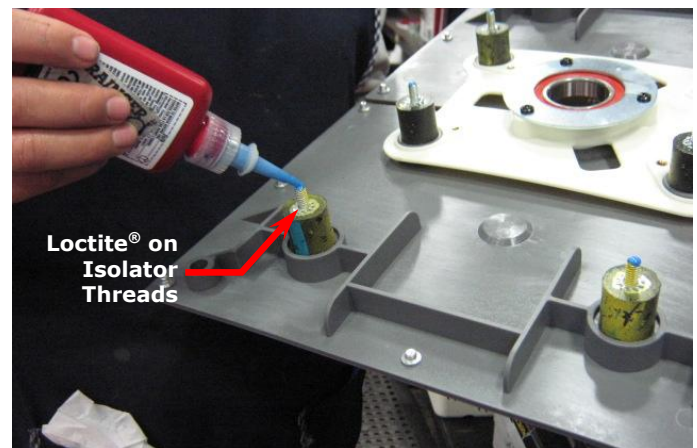

Figure 14 – Applying Loctite® to the Isolator Threads

Step 4 Install the Eccentric with Bearing Shield into the Pad Driver Plate.

IMPORTANT!
If replacing the eccentric or motor, apply anti seize to the bore of the eccentric before assembling the motor shaft.

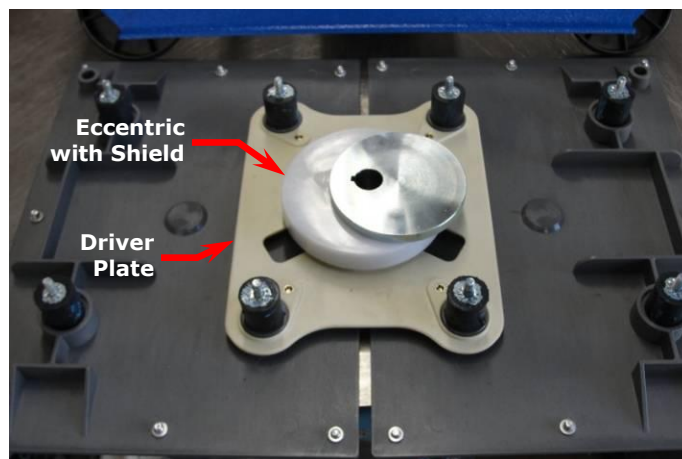

Figure 15 – Eccentric with Bearing Shield Installed on Pad Driver Plate

Step 5 Assemble the Scrub Deck to the Flex Plate Assembly.

Attach nuts to studs on the lower isolators (8 locations) to hold the deck in place. Tip onto edge to expose the motor shaft on the bottom of the deck.



Figure 16 – Attaching Nuts to Lower Isolator Studs

IMPORTANT!
Torque nuts to 8-10 ft-lbs.
Look at the lines on the lower isolators and make sure they are not twisted, which indicates they are over tightened.

Step 6 Install the Screw and Washer to fasten the Scrub Deck to the Motor Shaft.

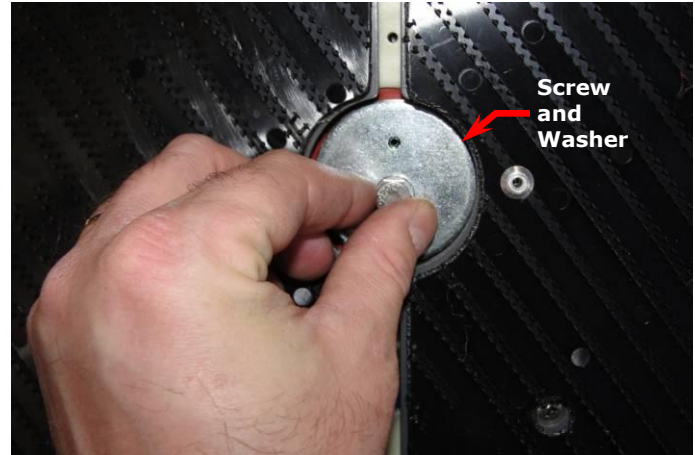

Figure 17 – Installing Motor Shaft Screw & Washer

Step 7 Install Upper Isolators into deck and hand tighten. Apply Loctite® to the threads of the Upper Isolators marked with a green stripe. On 28" & 32" decks Isolators will have red stripe.



Figure 18 – Applying Loctite® to Upper Isolator Threads

Step 8 Assemble the Scrub Deck to the Mounting Bracket.

IMPORTANT!
Torque nuts to 8-10 ft-lbs.
Look at the lines on the upper isolators and make sure they are not twisted, which indicates they are over tightened.

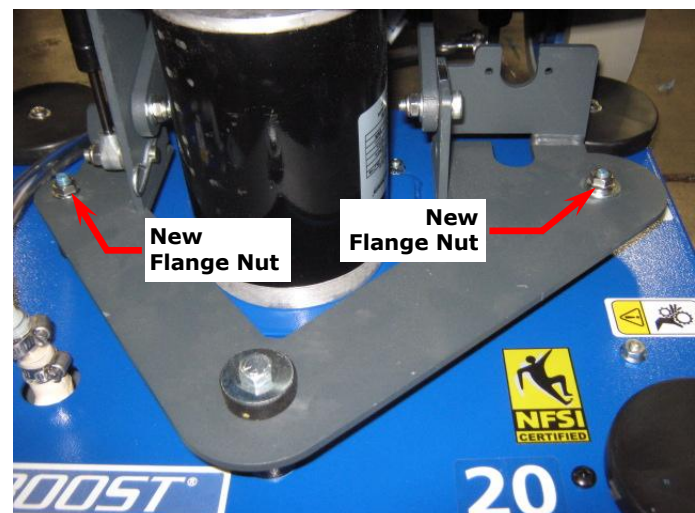

Figure 19 – Scrub Deck Assembled to Mounting Bracket (20" Deck shown)