



# DriMaster HiFlo Upholstery Tool Owner's Manual

**Model 000-163-012**

***HydraMaster / U.S. Products North America, Inc.  
11015 47<sup>th</sup> Avenue West, Mukilteo, Washington 98275***

MAN-33123 Rev. 4, February 15, 2013  
(182-801)

No part of this manual may be reproduced or used in any form or by any means (i.e. graphic, electronic, photocopying or electronic retrieval systems) without the express written permission of HydraMaster / U.S. Products Specifications and information in this document are subject to change without prior notice. All rights reserved. © 2013 HydraMaster / U.S. Products

**This page intentionally left blank.**



# Table of Contents

|  |                  |
|--|------------------|
| <b>GENERAL INFORMATION.....</b>                        | <b>SECTION 1</b> |
| Contact Information.....                               | 1-2              |
| Warnings, Cautions and Notices.....                    | 1-3              |
| <b>OPERATING INSTRUCTIONS.....</b>                     | <b>SECTION 2</b> |
| Optional Accessory Handle Assembly.....                | 2-1              |
| Begin Cleaning.....                                    | 2-2              |
| <b>TOOL MAINTENANCE.....</b>                           | <b>SECTION 3</b> |
| Removing and Re-installing the Clear Window Cover..... | 3-1              |
| Cleaning the Solution Bar Jet.....                     | 3-2              |
| Cleaning the Filter Cartridge and Orifice Plate.....   | 3-3              |
| <b>ASSEMBLIES AND PARTS LISTS.....</b>                 | <b>SECTION 4</b> |
| Handpiece Assembly Parts List.....                     | 4-3              |
| Accessory Handle Assembly Parts List.....              | 4-4              |
| Hide-A-Hose Assembly Parts List.....                   | 4-7              |
| <b>HOW TO ORDER PARTS.....</b>                         | <b>SECTION 5</b> |
| Warranty Parts Orders.....                             | 5-1              |
| Parts Orders.....                                      | 5-1              |
| Emergencies.....                                       | 5-1              |
| <b>WARRANTY INFORMATION.....</b>                       | <b>SECTION 6</b> |



# List of Figures

|  |     |
|--|-----|
| Figure 1-1. DriMaster HiFlo Upholstery Tool .....                                      | 1-1 |
| Figure 1-2. Optional Accessory Handle Attached to Tool .....                           | 1-1 |
| Figure 2-1. Remove Tool Screws .....   | 2-1 |
| Figure 2-2. Attach Accessory Handle .....  | 2-1 |
| Figure 2-3. Attach Solution Hose and Adjust Water Volume .....                         | 2-2 |
| Figure 2-4. Turning Knob to “HiFlo” Position Forms Sheet of Water Across Bar Jet... .. | 2-3 |
| Figure 3-1. Remove Vacuum Hose Cuff.....   | 3-1 |
| Figure 3-2. Remove Knob .....  | 3-1 |
| Figure 3-3. Remove Screws.....   | 3-1 |
| Figure 3-4. Separate Cover Halves.....   | 3-1 |
| Figure 3-5. Slide Cover into Half of Tool Body .....                                   | 3-2 |
| Figure 3-6. Clean Debris from Opening .....  | 3-2 |
| Figure 3-7. Disassemble Solution Quick Connect.....                                    | 3-3 |
| Figure 3-8. Remove Filter Cartridge and Plate Orifice .....                            | 3-3 |
| Figure 3-9. Re-assemble Solution Quick Connect.....                                    | 3-3 |
| Figure 4-1. Handpiece Assembly .....   | 4-2 |
| Figure 4-2. Accessory Handle Assembly.....   | 4-4 |
| Figure 4-3. Hide-A-Hose Assembly - Parts View 1 of 2 .....                             | 4-5 |
| Figure 4-4. Hide-A-Hose Assembly - Parts View 2 of 2 .....                             | 4-6 |

# 1 - General Information

Congratulations on purchasing the very latest in upholstery cleaning technology.

The patented DriMaster HiFlo Upholstery Tool, shown in Figure 1-1, is perfect for cleaning upholstery, fabric and stairs. Because of its Jetless Cleaning Technology, it has no trigger valve, no spray jet and never needs a separate dry pass.\*

The tool's new design incorporates light weight, extremely durable materials, giving the tool increased levels of strength and comfort.

The DriMaster HiFlo Upholstery Tool accommodates high volume jobs where production rate is important.

It is capable of solution flow rates for jobs that require a flushing action which makes the tool particularly efficient for stair cleaning.

An optional accessory handle, shown attached to the tool in Figure 1-2, is available to increase comfort on long cleaning jobs.

We trust that you will enjoy many years of reliable upholstery cleaning with the DriMaster HiFlo Upholstery Tool.

## NOTICE

The DriMaster HiFlo Upholstery Tool can be used with a variety of HydraMaster / U.S. Products cleaning systems.



Figure 1-1. DriMaster HiFlo Upholstery Tool



Figure 1-2. Optional Accessory Handle Attached to Tool

\* U.S. Patent No. 6,243,914; 7,070,662; RE39,623; D590,111  
New Zealand Patent No. 549645  
Other U.S. and Foreign Patents Pending



## CONTACT INFORMATION

If you have any questions regarding the operation, maintenance or repair of this upholstery tool, please contact your local distributor.

To find a local distributor, please visit our website at <http://www.hydraster.com/owners/locate/index.asp> or <http://www.usproducts.com/findadealer.aspx>.

If your question cannot be resolved by your distributor or by the information within this manual, you may contact Customer Care direct using the following phone numbers.

| <b>Hours</b>           | <b>Telephone Numbers</b>              | <b>E-mail Addresses</b>  |
|------------------------|---------------------------------------|--|
| Monday-Friday          | (425) 775-7275 Service                | Tech Support:<br>techsupport@hydraster.com<br>techsupport@usproducts.com |
| 7:00 a.m. to 5:00 p.m. | (425) 775-7276 Parts                  | Parts Support:<br>csorders@hydraster.com<br>csorders@usproducts.com      |
| Pacific Time           | (800) 426-4225 Parts /<br>Service FAX |  |

When calling your distributor, be sure to reference the serial number and date of purchase.

### FOR YOUR REFERENCE:

**Serial No.** \_\_\_\_\_

**Date of Purchase:** \_\_\_\_\_

**Purchased From (Distributor):** \_\_\_\_\_

## WARNINGS, CAUTIONS AND NOTICES

### **⚠ WARNING**

HydraMaster / U.S. Products uses this WARNING symbol throughout the manual to warn of possible injury or death.

### **CAUTION**

This CAUTION symbol is used to warn of possible equipment damage.

### **NOTICE**

This NOTICE symbol indicates that federal or state regulatory laws may apply, and also emphasizes supplemental information.



**This page intentionally left blank.**



## 2 - Operating Instructions

Your DriMaster HiFlo Upholstery Tool has been engineered using the latest and most sophisticated technology available to produce the finest upholstery cleaning results possible. Despite this, it remains only a tool of the upholstery cleaning trade and can produce only as good a job as the person operating it.

**HydraMaster / U.S. Products strongly recommends attending an Institute of Inspection, Cleaning and Restoration Certification (IICRC) approved Upholstery Cleaning course as soon as possible and to always follow the IICRC guidelines when cleaning.**

### OPTIONAL ACCESSORY HANDLE ASSEMBLY

The DriMaster HiFlo Upholstery Tool can be equipped with an optional accessory handle (purchased separately) to increase comfort and control during difficult or extended repetitive use of the upholstery tool.

1. Remove the two screws, nuts, and washers found on the handle grip portion of the tool (Figure 2-1). These parts will be reused in fastening the handle.



**Figure 2-1. Remove Tool Screws**

2. Attach the accessory handle as shown in Figure 2-2. The original shorter screws, nuts, and washers are used on the upper handle. The longer supplied screws, nuts and washers are used to connect the handle to the tool body.



**Figure 2-2. Attach Accessory Handle**



## BEGIN CLEANING

### **⚠ WARNING**

Do not use the DriMaster HiFlo Upholstery Tool on a machine exceeding 14" Hg vacuum and 500 psi solution pressure. Personal injury could result.

1. Attach the solution hose to the solution quick connect. A 1 ½" - 2" vacuum hose can be attached to the vac hose manifold (see Figure 2-3).

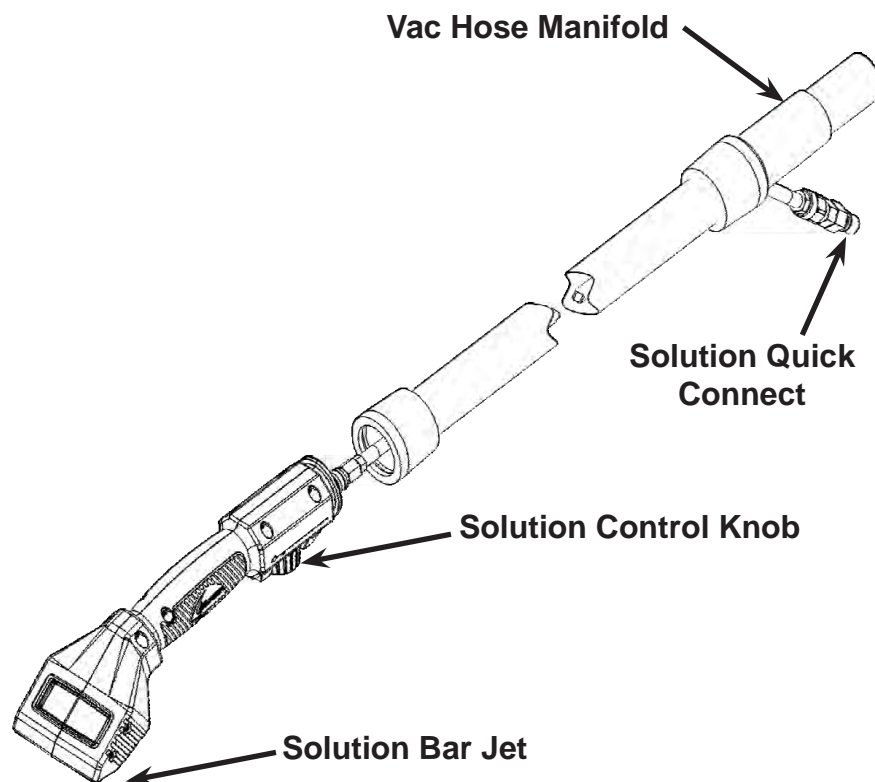

**Figure 2-3. Attach Solution Hose and Adjust Water Volume**

2. Adjust the water volume by turning the solution control knob. Turning the knob counterclockwise increases the water volume; turning the knob clockwise decreases the water volume. The amount of water volume you need will vary with the type of machine you are cleaning with and the type of material you are cleaning.
3. To begin adjustment, make sure the cleaning machine is running and both vacuum and solution hoses are connected.
4. Slowly open the solution control knob until water is flowing across the entire bar jet (without overspray).

When the solution knob is turned toward the “HiFlo” position, the water will form a sheet across the solution bar jet (see Figure 2-4)

## NOTICE

The amount of vacuum and pressure produced by your machine will determine the overspray on the solution bar jet. The patented solution bar jet makes a trigger valve unnecessary.

## ⚠ WARNING

Do not touch the solution bar jet during operation or immediately afterward; doing so may cause severe burns!

## CAUTION

When cleaning stairs, do not allow the tool to come into contact with the tack strip along the edges of the stairs. The tool’s cleaning surface will be damaged by the tack strip. Equipment damage such as this is not covered by warranty.

## NOTICE

It may be necessary to periodically clean the inside of the tool, hose and manifold. Debris can build up over time, restricting the vacuum flow (see Figure 3-6).



**Figure 2-4. Turning Knob to “HiFlo” Position Forms Sheet of Water Across Bar Jet**



**This page intentionally left blank.**

# 3 - Tool Maintenance

## REMOVING AND RE-INSTALLING THE CLEAR WINDOW COVER

1. Remove vacuum hose cuff from DriMaster HiFlo Upholstery Tool and disconnect the solution hose quick connect as shown in Figure 3-1.

### NOTICE

Lightly heating the “cuff” with a heat gun will make the cuff easier to remove and install.

2. Remove the solution control knob by removing the 8/32” set screw as shown in Figure 3-2.
3. Loosen, but do not remove, the valve retention nut (see arrow in Figure 3-3).
4. Remove all screws from both sides of the tool (see Figure 3-3) and carefully separate the tool halves (see Figure 3-4).



Figure 3-1. Remove Vacuum Hose Cuff



Figure 3-2. Remove Knob



Figure 3-3. Remove Screws



Figure 3-4. Separate Cover Halves



5. Slide the clear window cover off of the tool body.
6. To re-install the clear window cover, slide it into one half of the tool body (see Figure 3-5). Then slide the other half of the body into the window.

The clear window has grooves on either side that slide onto the edges of the cutouts in the tool bodies.



**Figure 3-5. Slide Cover into Half of Tool Body**

## NOTICE

The wear plates must be aligned and slid onto the tool halves at the same time as the cover.

## CAUTION

The window cover may come out if not installed properly.

7. Continue to assemble the two halves of the tool together, with the clear window being captured in the cutouts. Careful attention must be paid when sliding the two body halves together.
8. Re-install the body screws that were removed in step 4, page 3-1.
9. Apply Loctite® 245 to the threads of the valve. Tighten the valve retention nut. Do not overtighten.
10. Apply Loctite 245 to the valve control knob set screw. Tighten set screw securely.

### CLEANING THE SOLUTION BAR JET

The solution bar jet needs to be cleaned with a .020" feeler gauge.

1. Slide the feeler gauge into the small slot.
2. Gently slide the gauge back and forth to clear any debris from the opening (see Figure 3-6).



**Figure 3-6. Clean Debris from Opening**

## CAUTION

Use only a feeler gauge to clean the slot in the bar jet. Use of any other implement (paper clip, knife blade) may damage the opening and seriously reduce the cleaning effectiveness of the upholstery tool.

## NOTICE

HydraMaster / U.S. Products recommends you clean the filter cartridge and orifice plate on a periodic basis to eliminate hard water deposit buildup. Both components are conveniently located in the solution quick connect subassembly.

DriMaster HiFlo Upholstery Tools manufactured before April 9, 2009 will not include the Bar Jet Assembly (P/N 000-076-088) and therefore will not include the filter and orifice.

Disassemble the solution quick connect to gain access to the filter cartridge and orifice plate (see Figure 3-7 through Figure 3-9).

### CLEANING THE FILTER CARTRIDGE AND ORIFICE PLATE

1. Remove the filter cartridge and orifice plate, place them in a cup full of white vinegar and soak for 30 minutes.
2. Clean the orifice plate's opening with a wooden skewer or similar tool such as a plastic pick.

## CAUTION

Do not use a metal object to clean the opening of the orifice plate; doing so can damage the plate.

3. Remove both parts from the vinegar and thoroughly rinse them with clear water.
4. Re-assemble the solution quick connect, re-installing the filter cartridge and orifice plate in the proper order (see arrows in Figure 3-9).

## CAUTION

Do not operate the DriMaster HiFlo Upholstery Tool without the orifice plate. If you do not properly re-install the orifice plate in the solution quick connect (see Figure 3-9), equipment damage could result. Such equipment damage is not covered by warranty.

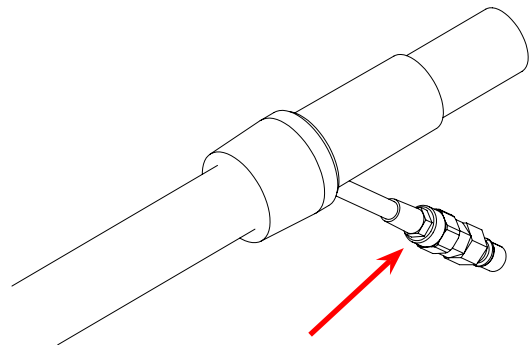

**Figure 3-7. Disassemble Solution Quick Connect**

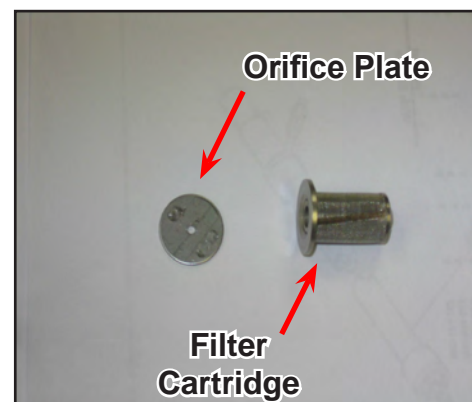

**Figure 3-8. Remove Filter Cartridge and Plate Orifice**

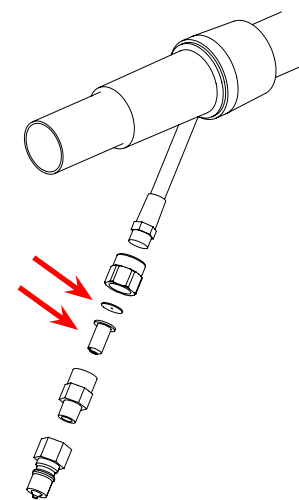

**Figure 3-9. Re-assemble Solution Quick Connect**



**This page intentionally left blank.**



# 4 - Assemblies and Parts Lists

This section contains all the assemblies and parts lists associated with the upholstery tool:

- Handpiece Assembly Parts List
- Accessory Handle Assembly Parts List
- Hide-A-Hose Assembly Parts List

**Figure 4-1. Handpiece Assembly**  
6960 Rev. F

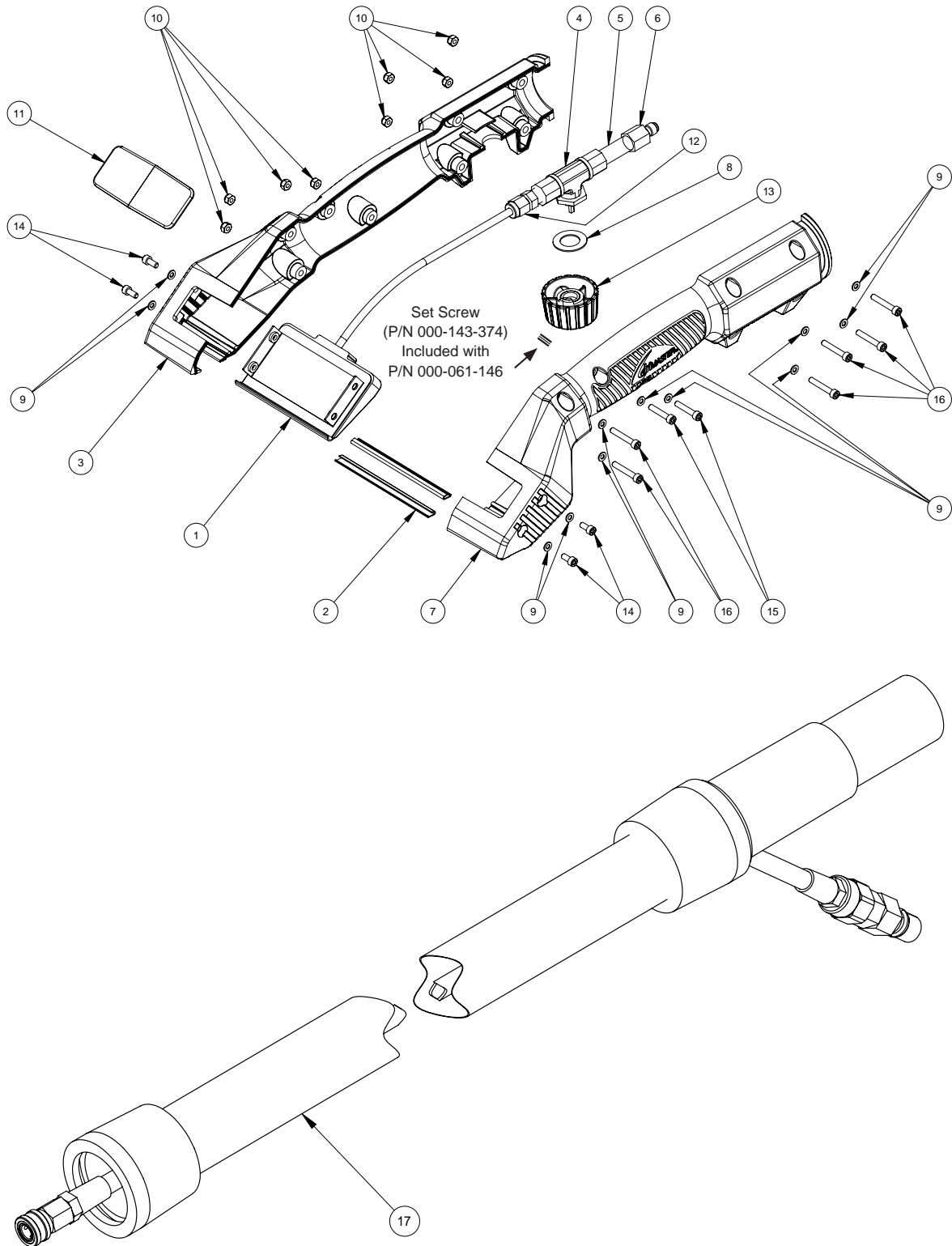



## Handpiece Assembly Parts List

| Item | Part Number | Description                                    | Qty |
|------|-------------|--|-----|
| 1    | 000-076-088 | Jet, DriMaster HiFlo Bar Assembly*             | 1   |
| 2    | 000-105-533 | Plate, Wear - DriMaster HiFlo                  | 2   |
| 3    | 000-061-138 | Handle, Handpiece, Left, DriMaster HiFlo       | 1   |
| 4    | 000-169-014 | Valve, Ball                                    | 1   |
| 5    | 000-052-762 | 1/8" NPT X 1.5                                 | 1   |
| 6    | 000-052-433 | Quick Disconnect, Male 1/8" NPT                | 1   |
| 7    | 000-061-139 | Handle, Handpiece, Right, DriMaster HiFlo      | 1   |
| 8    | 000-174-168 | Washer, Flat, .875 O.D. X .515 I.D X .035 Thk  | 1   |
| 9    | 000-174-167 | Washer, Flat, .248 O.D. X .128 I.D. X .029 Thk | 12  |
| 10   | 000-094-063 | Nut, #6-32UNC Nylock                           | 8   |
| 11   | 000-041-445 | Cover, DriMaster HiFlo Window                  | 1   |
| 12   | 000-052-541 | 1/8" NPT X .1875 O.D.                          | 1   |
| 13   | 000-061-146 | Assembly, Knob Custom Insert With Label        | 1   |
| 14   | 000-143-576 | Capscrew, Socket Head, 6-32 X 5/16             | 4   |
| 15   | 000-143-577 | Capscrew, Socket Head, 6-32 X 3/4              | 2   |
| 16   | 000-143-578 | Capscrew, Socket Head, 6-32 X 7/8              | 6   |
| 17   | 000-068-667 | Assembly, Hide-A-Hose                          | 1   |

### NOTICE

\* DriMaster HiFlo Upholstery Tools manufactured before April 9, 2009 will not include this Bar Jet Assembly (P/N 000-076-088) and therefore will not include the filter and orifice (see Figure 4-4).



**Figure 4-2. Accessory Handle Assembly**  
6958 Rev. B

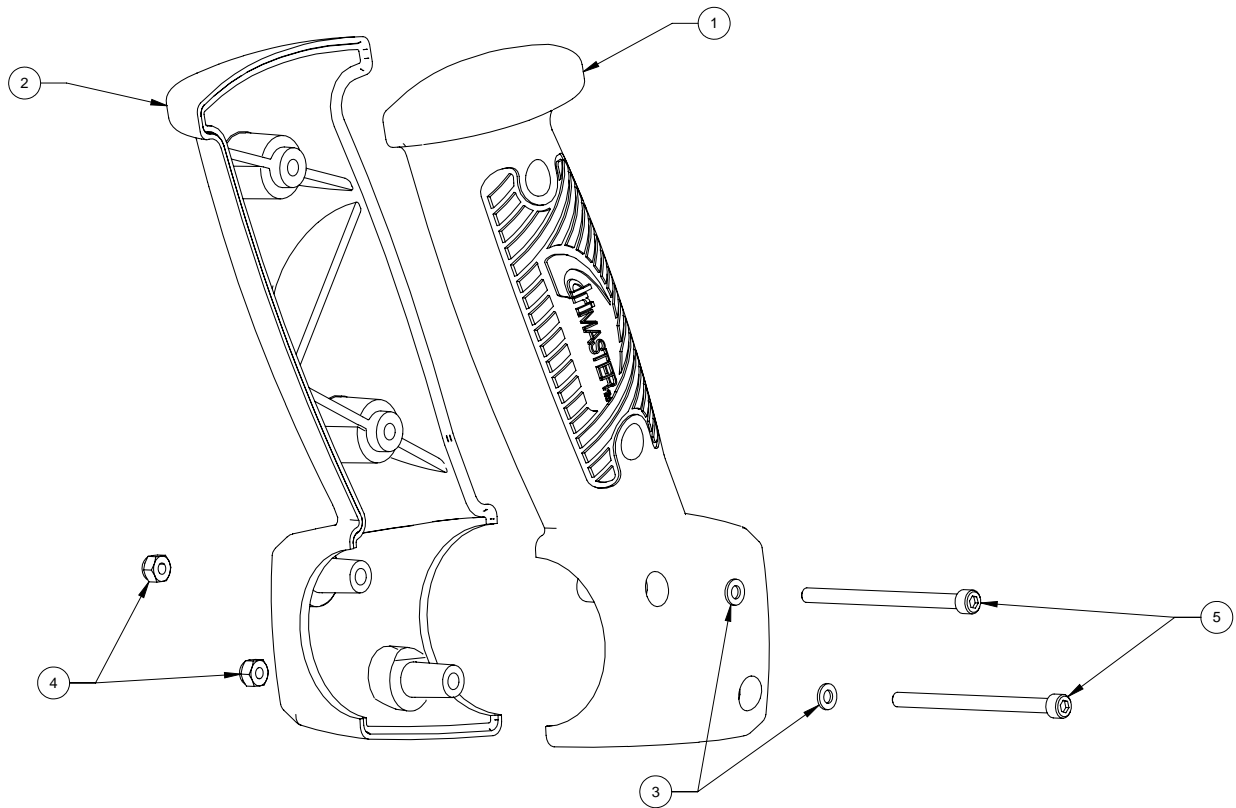

### Accessory Handle Assembly Parts List

| Item | Part Number | Description                                    | Qty |
|------|-------------|--|-----|
| 1    | 000-061-142 | Handle, Accessory, Right                       | 1   |
| 2    | 000-061-141 | Handle, Accessory, Left                        | 1   |
| 3    | 000-174-167 | Washer, Flat, .248 O.D. X .128 I.D. X .029 Thk | 2   |
| 4    | 000-094-063 | Nut, #6-32UNC Nylock                           | 2   |
| 5    | 000-143-579 | Cap Screw, Socket Head, #6-32 X 2              | 2   |

**Figure 4-3. Hide-A-Hose Assembly - Parts View 1 of 2**  
6959 Rev. E

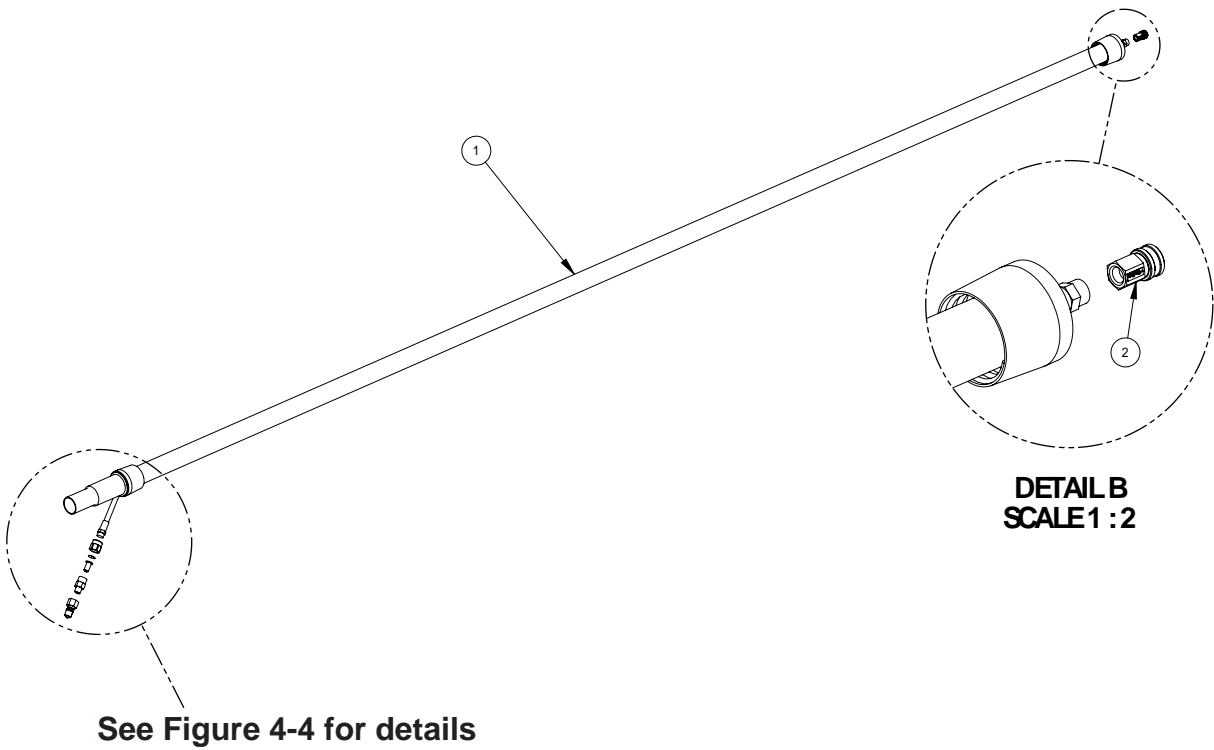



**Figure 4-4. Hide-A-Hose Assembly - Parts View 2 of 2**  
6959 Rev. E

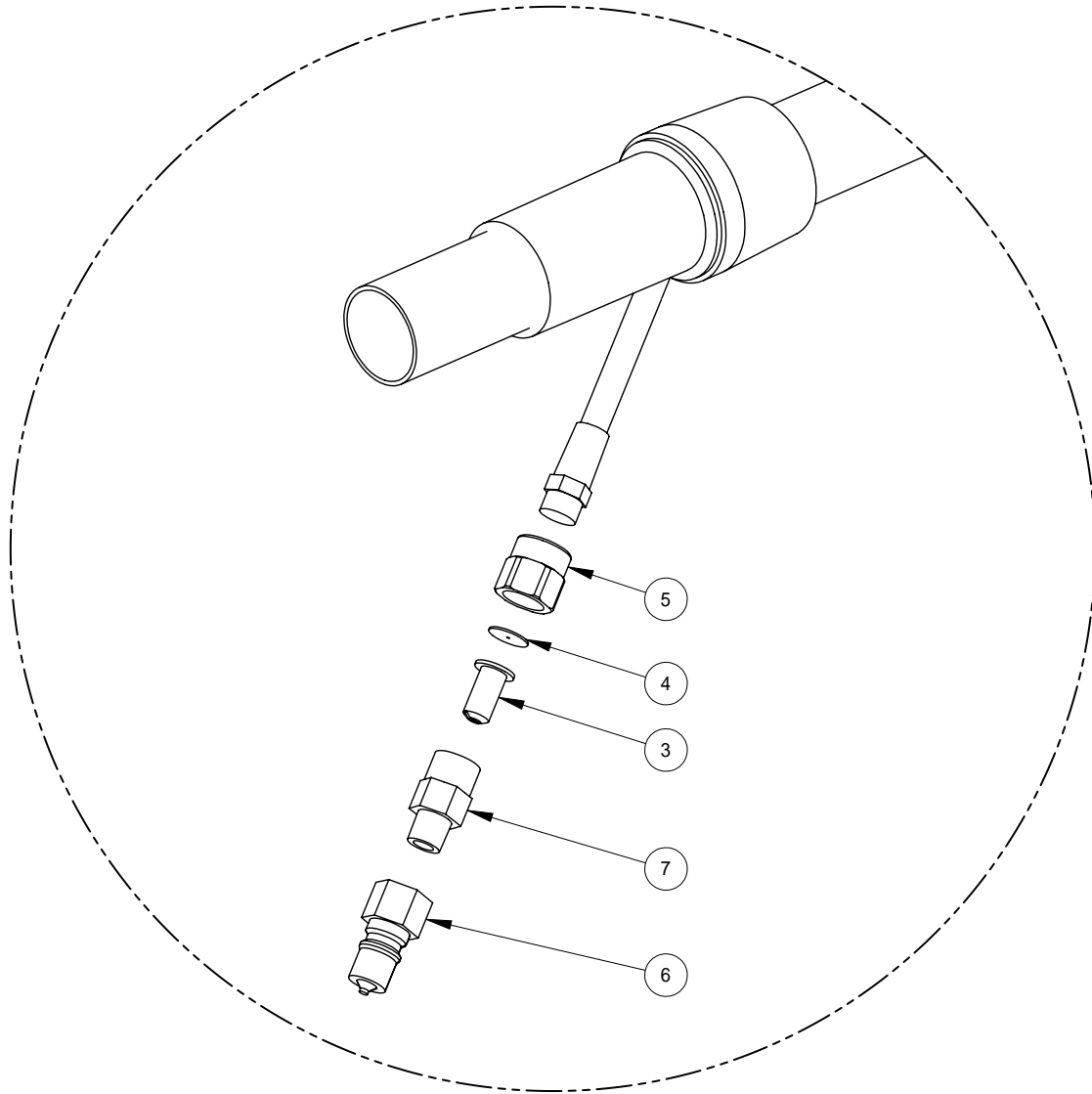



### Hide-A-Hose Assembly Parts List

| Item | Part Number | Description                          | Qty |
|------|-------------|--------------------------------------|-----|
| 1    | - - -       | Hose, Hide-A-Hose Raw                | 1   |
| 2    | 000-052-434 | Quick Connect, Female, 1/8" - Open   | 1   |
| 3    | 000-049-052 | Filter Cartridge, 1/4" Brass         | 1   |
| 4    | 000-180-023 | Orifice, Plate 0.045" *              | 1   |
| 5    | 000-094-118 | Nut, Brass Jet X 1/4" FNPT           | 1   |
| 6    | 000-052-050 | Quick Connect, 440 Male w/ Viton Std | 1   |
| 7    | 000-052-171 | Housing, 1/4" Brass Filter           | 1   |

#### NOTICE

\* DriMaster HiFlo Upholstery Tools manufactured before April 9, 2009 will not include the Bar Jet Assembly (P/N 000-076-088) and therefore will not include the filter and orifice.



**This page intentionally left blank.**





# 5 - How to Order Parts

From time to time, cleaning equipment may wear or malfunction. To obtain a proper diagnosis of your malfunction, and to order warranty replacement parts or arrange for repairs, it is important that you proceed in the following manner:

## WARRANTY PARTS ORDERS

1. Call the local distributor where you purchased your equipment and ask for the Service Department.
2. Have the following information ready:
  - a. Equipment Model
  - b. Date of Purchase
  - c. Description of Malfunction
3. Once it has been determined which parts are needed to correct the problem with your tool, make arrangements with your distributor to either perform the repairs or ship the parts to you.

## PARTS ORDERS

Call your local distributor. In most instances, they either stock or have access to parts through a regional service center.

## EMERGENCIES

If, for any reason, your distributor is unable to supply you with the necessary parts, they may call us and arrange for expedited shipping.

HydraMaster / U.S. Products sells parts only through authorized distributors and service centers.

HydraMaster / U.S. Products warranty covers only defective materials and/or workmanship for the periods listed. **Labor and/or diagnostic reimbursement is specifically excluded.**



**This page intentionally left blank.**



## 6 - Warranty Information

All parts of the DriMaster HiFlo upholstery tool are warranted against defects for one year.

Freezing, hard water, the use of unapproved solvents and/or abuse will void the warranty.

HydraMaster / U.S. Products warranty covers only defective materials and/or workmanship for the period listed. **Labor and/or diagnostic reimbursement is specifically excluded.**

If you have moved to a new area or have purchased a used machine and need information regarding your local distributor, call (425) 775-7272.



**This page intentionally left blank.**