

ALTO®

CLARKE

TECHNOLOGY

Operator's Manual

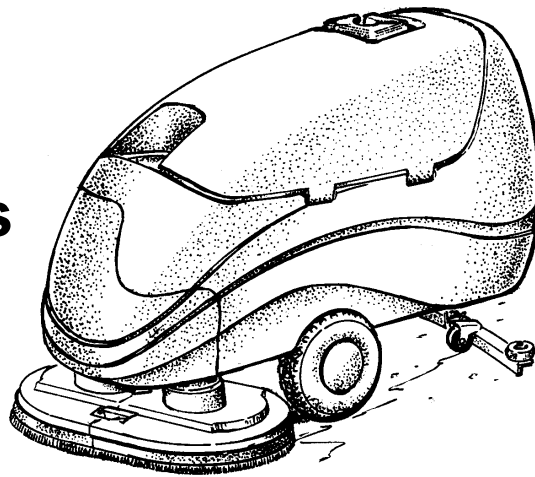

ENCORE
S28/L28
S33/L33
S38/L38

READ THIS BOOK

This book has important information for the use and safe operation of this machine. Failure to read this book prior to operating or attempting any service or maintenance procedure to your Clarke Technology machine could result in injury to you or to other personnel; damage to the machine or to other property could occur as well. You must have training in the operation of this machine before using it. If your operator(s) cannot read English, have this manual explained fully before attempting to operate this machine.

Si Ud. o sus operadores no pueden leer el Inglés, se hagan explicar este manual completamente antes de tratar el manejo o servicio de esta máquina.

All directions given in this book are as seen from the operator's position at the rear of the machine.

For new books write to: ALTO U.S. Inc., 2100 Highway 265, Springdale, Arkansas 72764.

Table of Contents

Operator Safety Instructions	3
Introduction & Machine Specifications "L" Class	5
Introduction & Machine Specifications "S" Class	6
Procedures For Transporting	7
Symbols Used On Encore Machines	8
Machine Control Panel "S" Class	10
Machine Control Panel "L" Class	11
Machine Controls and Features	13
How To Prepare The Machine For Operation	14
How To Install The Batteries	14
Battery Maintenance	15
How To Charge The Batteries	16
How To Install The Brushes Or Pad Drivers	17
How To Remove The Brushes Or Pad Drivers	17
How To Operate The Machine	18
How To Operate The Squeegee	18
How To Fill The Solution Tank	18
How To Clean A Floor	20
Maintenance	21
Accessories	26

Section II Parts and Service Manual

How To Correct Problems In The Machine	28
Maintenance, Head Position System	29
Encore Squeegee/Swing Arm Assembly Drawing	30
Parts List	31
Encore Traverse System Assembly Drawing	32
Parts List	33
Encore Brush Head Assembly Drawing	34
Parts List	35
Encore Solution/Recovery System Assembly Drawing	36
Parts List	37
Encore Control Housing Assembly Drawing	38
Parts List	39
Encore Rear Cover Assembly Drawing	40
Parts List	41
Encore Brush Motor Drawing & Parts List	42
Encore Gear Box Assembly Drawing & Parts List	43
Encore Vac Motor	44
Encore S28/S33/S38 Brake and Transaxle Stature & L28 "Soft Start" Transaxle Stature	45
Encore L33/L38 Brake and Transaxle Imperial	46
36 Volt Battery Charger Drawing & Parts List	47
Encore S28/S33/S38 Electrical Schematic	48
Encore S28/S33/S38 Connection Diagram	49
Encore L28/L33/L38 Electrical Schematic	50
Encore L28/L33/L38 Connection Diagram	51

OPERATOR SAFETY INSTRUCTIONS



WARNING



AVERTISSEMENT



ADVERTENCIA



DANGER:

Failure to read and observe all **DANGER** statements could result in severe bodily injury or death. Read and observe all **DANGER** statements found in your Owner's Manual and on your machine.



WARNING:

Failure to read and observe all **WARNING** statements could result in injury to you or to other personnel; property damage could occur as well. Read and observe all **WARNING** statements found in your Owner's Manual and on your machine.



CAUTION:

Failure to read and observe all **CAUTION** statements could result in damage to the machine or to other property. Read and observe all **CAUTION** statements found in our Owner's Manual and on your machine.



DANGER:

Failure to read the Owner's Manual prior to operating or attempting any service or maintenance procedure to your Clarke Technology machine could result in injury to you or to other personnel; damage to the machine or to other property could occur as well. You must have training in the operation of this machine before using it. If your operator(s) cannot read English, have this manual explained fully before attempting to operate this machine.



DANGER:

Operating a machine that is not completely or fully assembled could result in injury or property damage. Do not operate this machine until it is completely assembled. Inspect the machine carefully before operation.



DANGER:

Machines can cause an explosion when operated near flammable materials and vapors. Do not use this machine with or near fuels, grain dust, solvents, thinners, or other flammable materials. This machine is not suitable for picking up hazardous dust.



DANGER:

Lead acid batteries generate gases which can cause an explosion. Keep sparks and flames away from batteries. Do not smoke around the machine. Charge the batteries only in an area with good ventilation. Make sure that you unplug the AC charger from the wall outlet before disconnecting from the machine.



DANGER:

Working with batteries can be dangerous! Always wear eye protection and protective clothing when working near batteries. Remove all jewelry. Do not put tools or other metal objects across the battery terminals, or the tops of the batteries.



DANGER:

Using a charger with a damaged power cord could result in an electrocution. Do not use the charger if the power cord is damaged.



WARNING:

Operating this machine from anywhere other than the back of the machine could result in injury or damage. Operate this machine only from the rear.











WARNING:

This machine is heavy. Get assistance before attempting to transport or move it. Use two able persons to move the machine on a ramp or incline. Always move slowly. Do not turn the machine on a ramp. If operating machine on a gradient over 2%, do not stop, turn or park. Read the "Procedures For Transporting" in this manual before transporting.



WARNING:

Machines can topple over if guided over the edges of stairs or loading docks and cause injury or damage. Stop and leave this machine only on a level surface. When you stop the machine, turn the key "OFF". Set the parking brake.

-  **WARNING:** Maintenance and repairs performed by unauthorized personnel could result in damage or injury. Maintenance and repairs must be performed by authorized Clarke Technology personnel only.
-  **WARNING:** Any alterations or modifications of this machine could result in damage to the machine or injury to the operator or other bystanders. Alterations or modifications not authorized by the manufacturer voids any and all warranties and liabilities.
-  **WARNING:** Electrical components of this machine can "short-out" if exposed to water or moisture. Keep the electrical components of the machine dry. Wipe the machine down after each use. For storage, keep the machine in a dry building.
-  **WARNING:** Operating a machine without observing all labels and instructional information could result in injury or damage. Read all machine labels before attempting to operate. Make sure all of the labels and instructional information are attached or fastened to the machine. Get replacement labels and plates from your Clarke Technology distributor.
-  **WARNING:** Wet floor surfaces can be slippery. Water solutions or cleaning materials used with this type of machine can leave wet areas on the floor surface. These areas can cause a dangerous condition for the operator or other persons. Always put "Caution" signs around/near the area you are cleaning.
-  **WARNING:** Improper discharge of waste water may damage the environment and be illegal. The United States Environmental Protection Agency has established certain regulations regarding discharge of waste water. Also, city and state regulations regarding this discharge may be in your area. Understand and follow the regulations in your area. Be aware of the environmental hazards of chemicals that you dispose.
-  **CAUTION:** Use of this machine to move other objects or to climb on could result in injury or damage. Do not use this machine as a step or furniture. Do not ride on this machine.
-  **CAUTION:** Your machine warranty will be voided if anything other than genuine Clarke Technology parts are used on your machine. Always use Clarke Technology parts for replacement.

Introduction & Machine Specifications

Introduction & Machine Specifications

Clarke Technology's newly designed Encore 38, 33 and 28 automatic scrubbers are efficient and superior floor cleaning machines. The Encore 38 uses two brushes or pads to scrub a path 38 inches wide. The Encore 33 uses two brushes or pads to scrub a path 33 inches wide. The Encore 28 uses two brushes or pads to scrub a path 28 inches wide. A squeegee wipes the floor while the vacuum motor removes the dirty solution from the floor - all in one pass.

The Ecore 38, 33 and 28 automatic scrubbers come complete with six - 6 volt batteries, five battery connector cables, one battery cable assembly, one battery charger, either two brushes or two pad drivers, and one operator's manual.

SPECIFICATIONS:

Model	L38 - 00740A	L33 - 00720A	L28 - 00700A
Model w/Brakes	L38 - 00740E	L33 - 00720E	L28 - 00700E
Motor, Vac	1 HP (67kw) three stage tangential discharge	1HP (67kw) three stage tagential discharge	1HP (67kw)three stage tagential discharge
Power Supply	36 volt (6-6V batteries) 250AH, 330AH, or 370AH	36 volt (6-6V batteries) 250AH, 330AH, or 330AH	36 volt (6-6V batteries) 250AH, 330AH, or 370AH
Solution Tank	30 gallon (114 liter)	30 gallon (114 liter)	30 gallon (114 liter)
Recovery Tank	30 gallon (114 liter)	30 gallon (114 liter)	30 gallon (114 liter)
Motors, Brush (2)	1 hp PM (.74kw)	1hp PM (.74kw)	.75 hp PM (.56kw)
Motor Traction	.50 hp PM (.37kw)	.50 hp PM (.37kw)	.50 hp PM (.37kw)
Brushes (2)	19 inch (48cm) w/.5" (1.5cm) overlap	17 inch (43cm) w/1" (3cm) overlap	14 inch (36cm) w/.5" (1.5cm) overlap
Brush Speed	200 rpm	200 rpm	200 rpm
Brush Pressure	Variable 120 lbs-220lbs	Variable 120 lbs-220 lbs	Variable 120 lbs-220 lbs
Speed, Forward	Variable to 230 ft/min.	Variable to 230 ft/min.	Variable to 230 ft/min.
Speed, Reverse	Variable to 180ft/min.	Variable to 180ft/min.	Variable to 180ft/min.
Charger	36V, 25A, 115V/60hz	36V, 25A, 115V/60hz	36V, 25A, 115V/60hz
Length	66 inches (168cm)	63 inches (160cm)	62.5 inches (159cm)
Width - Machine	28 inches (71cm)	28 inches (71cm)	28 inches (71cm)
Height	44 inches (112cm)	44 inches (112cm)	44 inches (112cm)
Cleaning Rate	42,000 sq ft/hr (3,901 sq. m/hr)	35,000 sq ft/hr (3,252 sq. m/hr)	29,700 sq. ft/hr (2,750 sq. m/hr)
Cleaning Swath	38 inch	33 inch	28 inch (66cm)
Grade Cleaning	6° Incline	6° Incline	6° Incline
Weight w/Batteries (330AH)	1038 lbs. 471kg	1028 lbs. 467kg	1018 lbs. 462kg
Shipping Weight w/batteries (330AH)	1341 lbs. 608kg	1331 lbs. 604kg	1321 lbs. 599kg

Introduction & Machine Specifications (Con't)

SPECIFICATIONS:

Model	S38 - 00680A	S33 - 00660A	S28 - 00640A
Model w/Brake	S38 - 00680E	S33 - 00660E	S28 - 00640E
Motor, Vac	1 HP (67kw) three stage tangential discharge	1HP (67kw) three stage tagential discharge	1HP (67kw) three stage tagential discharge Power
Supply	36 volt (6-6V batteries) 250AH, 330AH, or 370AH	36 volt (6-6V batteries) 250AH, 330AH, or 330AH	36 volt (6-6V batteries) 250AH, 330AH, or 330AH
Solution Tank	30 gallon (114 liter)	30 gallon (114 liter)	30 gallon (114 liter)
Recovery Tank	30 gallon (114 liter)	30 gallon (114 liter)	30 gallon (114 liter)
Motors, Brush (2)	1 hp PM (.74kw)	.75 hp PM (.56kw)	.75 hp PM (.56kw)
Motor Traction	.50 hp PM (.37kw)	.50 hp PM (.37kw)	.50 hp PM (.37kw)
Brushes (2)	19 inch (48cm) w/.5" (1.5cm) overlap	17 inch (43cm) w/1" (3 cm) overlap	14 inch (36cm) w/.5" (1.5 cm) overlap
Brush Speed	200 rpm	200 rpm	200 rpm
Brush Pressure	150 lbs.	150 lbs.	150 lbs.
Speed, Forward	Variable to 230 ft./min.	Variable to 230 ft./min.	Variable to 230 ft./min.
Speed, Reverse	Variable to 180 ft./min.	Variable to 180 ft./min.	Variable to 180 ft./min.
Charger	36V, 25A, 115V/60hz	36V, 25A, 115V/60hz	36V, 25A, 115V/60hz
Length	66 inches (168cm)	63 inches (160cm)	62.5 inches (159cm)
Width - Machine	28 inches (71cm)	28 inches (71 cm)	28 inches (71 cm)
Height	44 inches (112cm)	44 inches (112 cm)	44 inches (112 cm)
Cleaning Rate	42,000 sq ft/hr (3,901 sq. m/hr)	35,000 sq ft/hr (3,252 sq. m/hr)	29,7000 sq ft./hr (2,750 sq ft./hr)
Cleaning Swath	37.5 inch (95.3cm)	33 inch (84cm)	28, inch (70cm)
Grade Cleaning	6° Incline	6° Incline	6° Incline
Weight w/Batteries (330AH)	1038 lbs. 471kg	1028 lbs. 467kg	1018 lbs. 462kg
Shipping Weight w/batteries (330AH)	1341 lbs. 608kg	1331 lbs. 604kg	1321 lbs. 599kg

PROCEDURES FOR TRANSPORTING

How To Put The Machine In A Van Or Truck

 **WARNING:** The machine is heavy. Make sure you use two able persons to assist the machine in climbing the ramp.

1. Make sure the loading ramp is at least eight (8) feet long, and strong enough to support the machine.
2. Make sure the ramp is clean and dry.
3. Put the ramp in position.
4. Remove squeegee assembly, brush housings, & brushes or pad drivers before loading.
5. Turn key switch "ON".
6. Align the machine on a level surface ten (10) feet in front of the ramp.
7. Put the traverse speed switch in the "HI" position.
8. Push the control handles toward the machine all the way.
9. Push the machine to the top of the ramp.
10. Turn the key switch "OFF".
11. Fasten the machine to the vehicle.

How To Remove The Machine From A Van Or Truck

1. Make sure there are no obstructions in the area.
2. Make sure the unloading ramp is at least eight (8) feet long and strong enough to support the machine.
3. Make sure the ramp is clean and dry.
4. Put the ramp in position.
5. Unfasten the machine.

 **WARNING:** The machine is heavy. Make sure you use two able persons to assist in moving the machine down the ramp.

6. Turn the key switch "ON".
7. Carefully and slowly, pull the machine to the top of the ramp.
8. Put the traverse speed switch in the "HI" position.
9. As the machine begins to travel down the ramp, push the control handles toward the machine to maintain a slow downward speed.
10. Replace squeegee assembly, brush housings, & brushes or pad drivers after the machine is unloaded and ready to use.

**SYMBOLS USED ON ENCORE S38, S33, & S28
and L38, L33, & L28**



Warning ("L Class" & "S Class')



Power ("L Class" & "S Class")

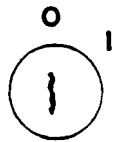

On/Off Key Switch ("L Class" & "S Class")

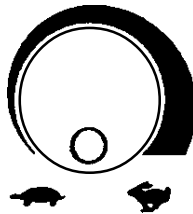

Traverse Speed Control ("L Class" & "S Class")



Solution Control ("L Class" & "S Class")



Brush Up/Down ("L Class" & "S Class")

**SYMBOLS USED ON ENCORE S38, S33 & S28
L38, L33, & L28**

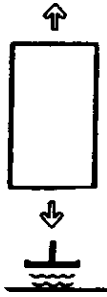

**Squeegee/Vacuum
("L Class" Only)**



**Battery Meter
("L Class" & "S Class")**

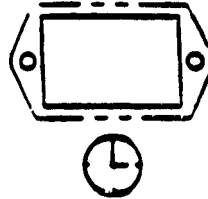

**Hour Meter
("L Class" & "S Class")**



**Brush Pressure
Increase/Decrease
("L Class" Only)**



**Warning Label
("L Class" & "S Class")
with parking brake**

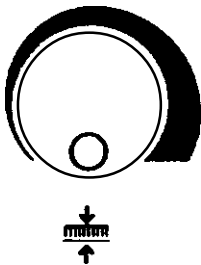

**Brush Pressure Meter
("L Class" Only)**



**Warning Label
("L Class" & "S Class")
without parking brake**

MACHINE CONTROL PANEL (S38, S33 & S28)

Key Switch (See Figure #1, Item "A")

The key switch turns "ON" the power to the control panel. "0" is "OFF" and "1" is "on".

Traverse Speed Switch (See Figure #1, Item "B")

The speed control varies from low to high speed. To increase the speed, turn the knob to the right. To decrease the speed, turn the knob to the left.

Brush Up/Down Switch (See Figure #1, Item "C")

The brush switch has two positions: "Up" positions the brushes up; "Down" positions the brushes on the floor. The brush motors start when the brushes are down.

Solution Control Knob (See Figure #1, Item "D")

The solution control knob regulates the flow of cleaning solution to the floor. To increase the flow turn the knob clockwise. To decrease the flow, turn the knob counter-clockwise.

Control Handle (See Figure #1, Item "E")

The control handle is located at the rear of the machine. It controls the direction of the machine. Push forward to go forward. (See Figure #3, page 10). Pull back to move in reverse. (See Figure #4, page 10).

Circuit Breakers (See Figure #1, Item "F"-"J")

The circuit breaker reset buttons are located on the rear cover, below the control handle. The breakers are located as follows: Item F & G - Brush Motors (35A)

Item H - Traverse Motor (30A)

Item I - Vac Motor (25A)

Item J - Actuator Motor, Brush Head (5A)

If a circuit breaker trips, determine which motor is not operating and turn the key switch "OFF". Wait five minutes and push the reset button back in. Turn the key switch "ON", and try again. An authorized service person should be contacted if the breaker trips again.

Hour Meter (See Figure #1, Item K)

The hour meter indicates the number of hours the machine has operated. It runs only when the machine is moving forward or reverse.

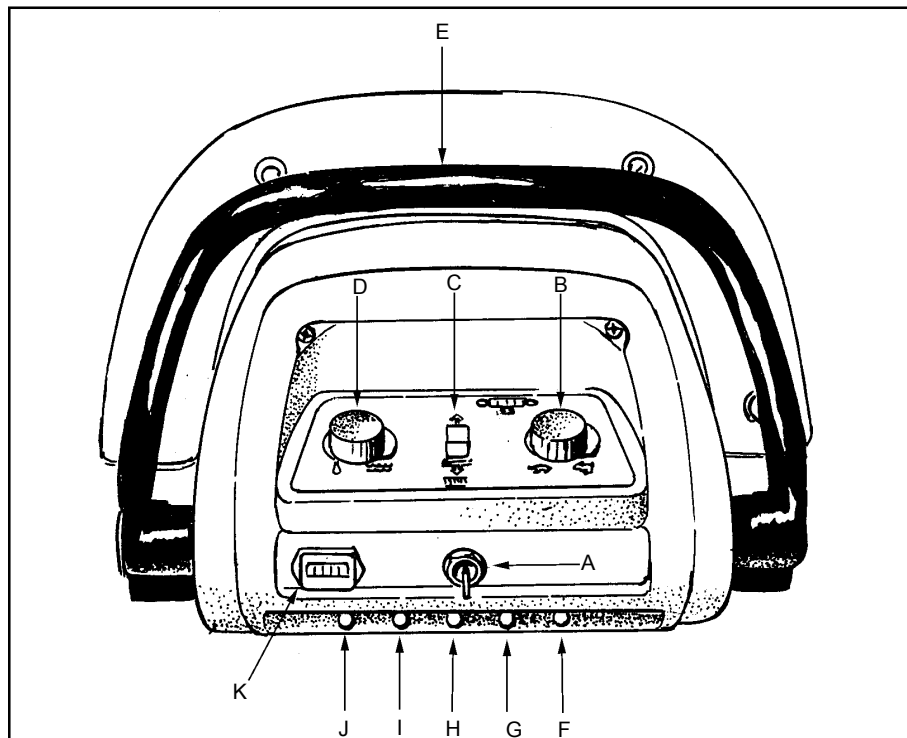

Figure #1

MACHINE CONTROL PANEL (L38, L33 & L28)

Key Switch (See Figure #2, Item "A")

The key switch turns "ON" the power to the control panel. "0" is "OFF" and "1" is "on".

Traverse Speed Control Knob (See Figure #2, Item "B")

The speed control varies from low to high speed. To increase the speed, turn the knob to the right. To decrease the speed, turn the knob to the left.

Brush Head Up/Down Switch (See Figure #2, Item "C")

The brush switch has two positions: "Up" positions the brushes up; "Down" positions the brushes on the floor. The brush motors will not run until the control handles are activated.

Brush Pressure Knob (See Figure #2, Item "D")

The brush pressure knob is used to increase the pressure on the brushes from the initial scrub position. Turn the knob counter clockwise to decrease pressure. Turn knob clockwise to increase pressure.

Solution Control Knob (See Figure #2, Item "E")

The solution control knob regulates the flow of cleaning solution to the floor. To increase the flow turn the knob clockwise. To decrease the flow, turn the knob counter-clockwise.

Squeegee/Vacuum Switch (See Figure #2, Item "F")

The 3 position squeegee switch positions the squeegee either: (1) Up with vac motor "OFF", (2) Up with vac motor "ON", or (3) Down with vac motor "ON". The squeegee will automatically raise up when the control handles are pulled into reverse.

Control Handle (See Figure #2, Item "G")

The control handle controls the direction that the machine moves. It is at the back of the machine. Push forward to go forward (see figure #3), pull back to move in reverse (see figure #4).

Note: The reverse speed is automatically reduced by approximately 30 percent. Releasing the control handle to the center position applies a dynamic brake to the traverse motor to slow the machine down. If the machine is scrubbing and the control handle is released, the brush motors will stop after two seconds.

Battery Meter (See Figure #2, Item "H")

The battery meter indicates the relative charge on the battery pack. Do not continue to run the machine when the meter is in "red" area. This will shorten the life of the battery.

Brush Pressure Meter (See Figure #2, Item "I")

The brush pressure meter indicates the relative amount of pressure the brushes or pads are putting on the floor. To maximize run time on a battery charge, keep the light bars towards the center of the green area. To avoid damage to the brush motors, do not run the machine in the "red" area.

Hour Meter (See Figure #2, Item "J")

The hour meter indicates the number of hours the machine has operated. It runs only when the machine is moving forward or reverse.

MACHINE CONTROL PANEL (L38, L33 & L28)

Circuit Breakers (See Figure #2, Item "K"-"P")

The circuit breaker reset buttons are located on the rear cover, below the control handle. The breakers are located as follows:

- Item K & L - Brush Motors (35A)
- Item M - Traverse Motor (30A)
- Item N - Vac Motor (25A)
- Item O - Actuator Motor, Brush Head (5A)
- Item P - Actuator Motor, Squeegee (1.5 Amp)

If a circuit breaker trips, determine which motor is not operating and turn the key switch "OFF". Wait five minutes and push the reset button back in. Turn the key switch "on" and try again. Contact an authorized service person if the breaker trips again.

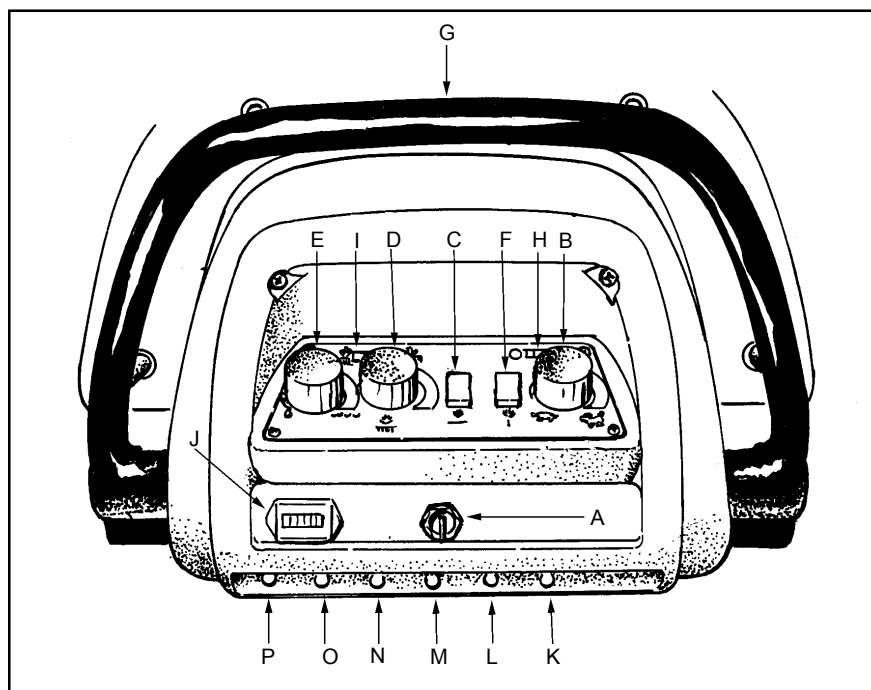

Figure #2

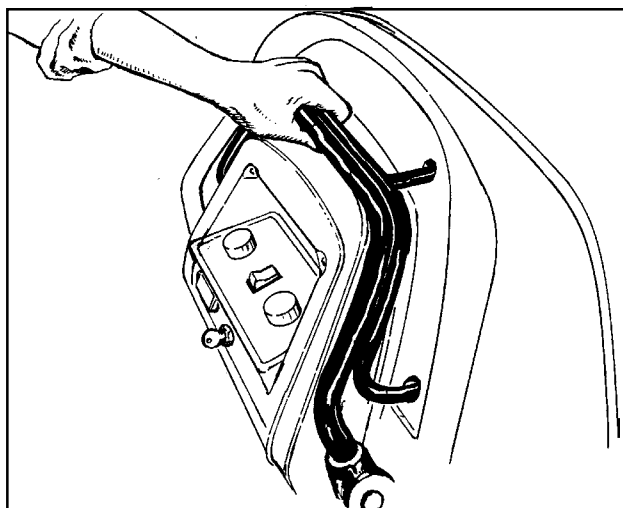

Figure #3

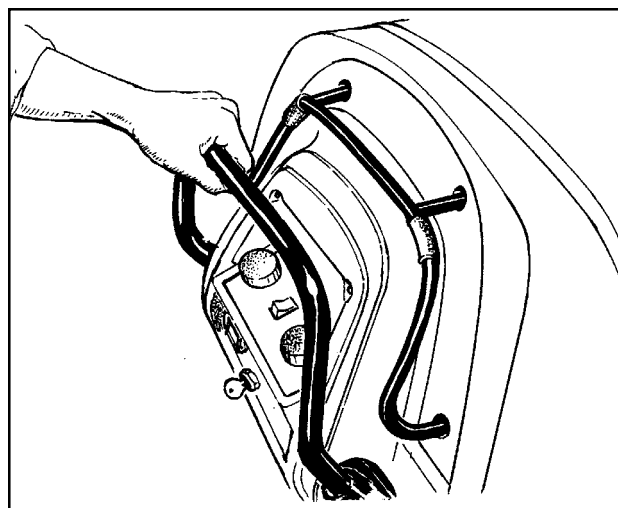

Figure #4

MACHINE CONTROLS & FEATURES

Squeegee Lift Handle See Figure #5a, 5b, & 5c.
The squeegee lift handle is located below the control handles on the right side. It is used to raise or lower the squeegee. The vac motor is turned on when the handle is lowered. (S38, S33 & S28 models only).

Parking Brake (Optional) See Figure #6.
The parking brake prevents movement of the machine. The brake is located on the left hand side of the transaxle motor. Turn the key switch off or disconnect the power to the battery to apply the brake.

There is a mechanical lever located on the brake. This lever is an override. To manually release the brake, rotate the lever toward the rear of machine (counter clockwise). To return the brake to normal or to apply the brake, rotate the lever towards the front of the machine (clockwise).

NOTE: If the lever is left in the override position, the brake will not function with the key switch, and the machine will not operate.

CAUTION: Do not activate the brake while the machine is moving.

Float Shut Off See Figure #7.
The shut-off switch for the vac motor is located in the recovery tank. It automatically turns off the vac motor when the recovery tank is full.

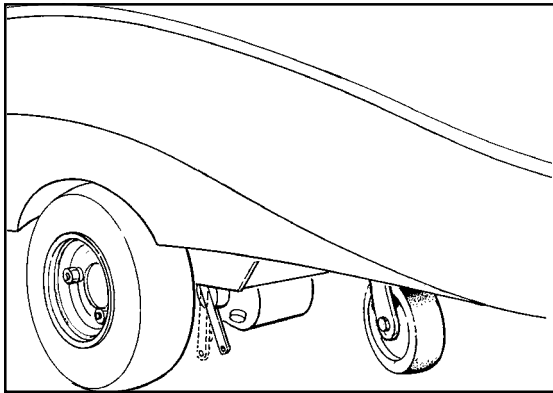

Figure #6

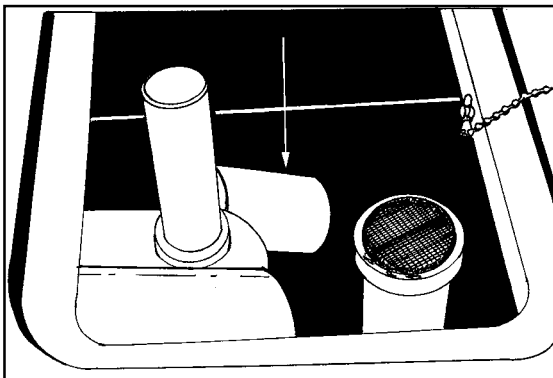

Figure #7

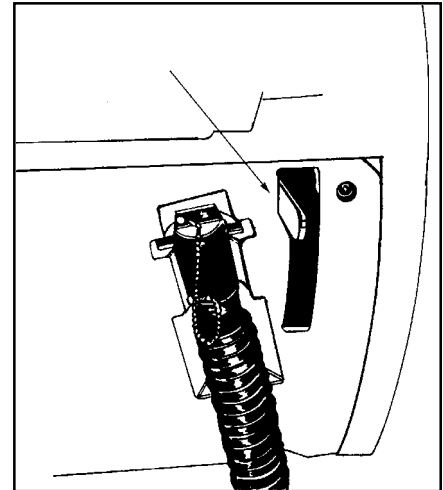

Figure #5a

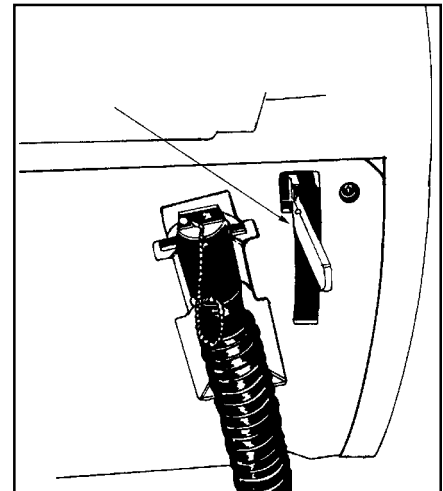

Figure #5b

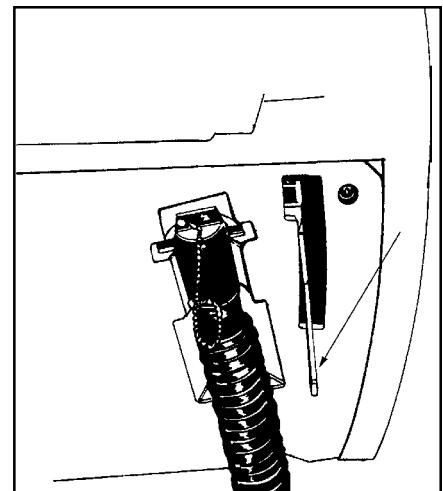

Figure #5c

HOW TO PREPARE THE MACHINE FOR OPERATION

How To Install The Batteries

The 38, 33 and 28 Encore machines use six 6-volt or three 12-volt batteries. The batteries are located in the battery compartment under the recovery tank.

To Install the batteries, follow this procedure:

1. Turn key switch off.
2. Make sure both tanks are empty.
3. Disconnect the hoses from the recovery tank (upper tank) & unplug the vac motor. Remove the recovery tank.
4. Place the batteries in the solution tank as shown in figures 8a - 8d.

⚠ WARNING: Lifting batteries without help could result in an injury. Get help to lift the batteries. The batteries are heavy.

⚠ WARNING: Working with batteries can be dangerous. Always wear eye protection and protective clothing when working near batteries. **NO SMOKING!**

5. Connect the battery cables between batteries and install long battery cable assembly as indicated. See figure 8a - 8d.

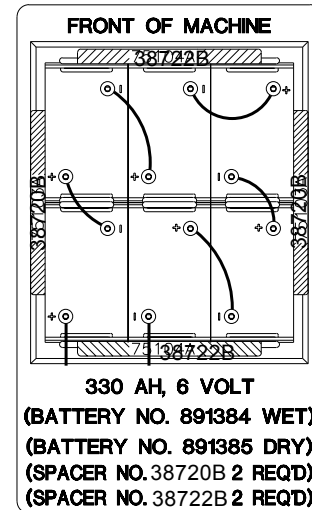

Figure #8a

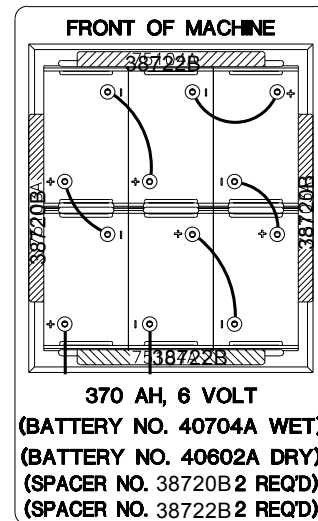

Figure #8b

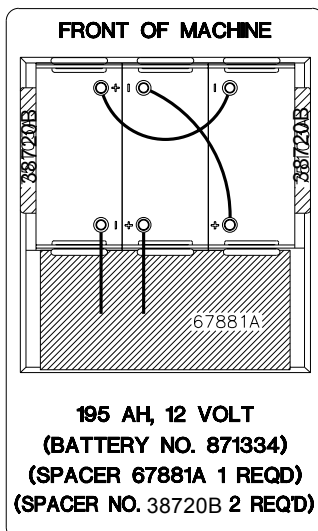

Figure #8c

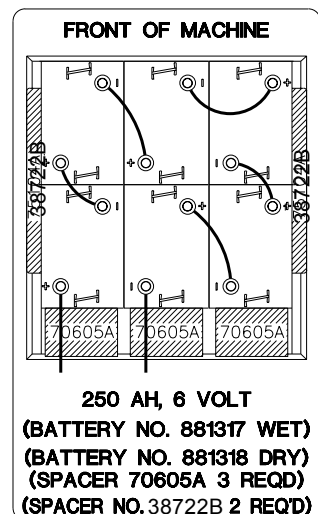

Figure #8c

HOW TO PREPARE THE MACHINE FOR OPERATION

6. Join the connector from the battery pack to the connector on the control panel. See figure #9.
7. Install the tank, reconnecting hoses and replace the two screws attaching the solution tank to the rear of the frame.

NOTE: Charge the batteries before using the machine.

Battery Maintenance

The electrical power to operate the machine comes from the storage batteries. Storage batteries need preventive maintenance.

⚠ WARNING: Working with batteries can be dangerous. Always wear eye protection and protective clothing when working near batteries. **NO SMOKING!**

To maintain the batteries in good condition, follow these instructions:

1. Keep the electrolyte at the correct level. The correct level is between 1/4" below the bottom of the tube in each cell and above the tops of the plates. Check the level of the electrolyte each time you charge the batteries. See figure #10.

NOTE: Check the level of electrolyte prior to charging the batteries. Be sure the plates in each cell are covered with electrolyte. Do not top off the cells prior to charging the battery. Electrolyte expands during charging. As a result, the electrolyte could overflow from the cells. Always top off the cells with distilled water after charging.

⚠ CAUTION: Irreversible damage will occur to the batteries if the electrolyte level does not cover the plates. Keep the electrolyte at the correct level.

⚠ CAUTION: Machine damage and discharge across the tops of the batteries can occur if the batteries are filled above the bottom of the tube in each cell. Do not fill the batteries up to the bottom of the tube in each cell. Wipe any acid from the machine or the tops of the batteries. Never add acid to a battery after installation.

⚠ CAUTION: Tap water may contain contaminants that will damage batteries. Batteries must be re-filled with distilled water only.

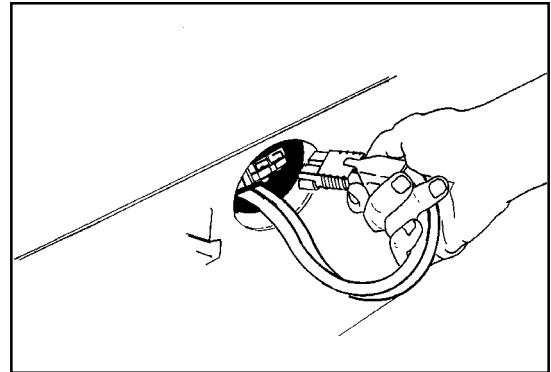

Figure #9

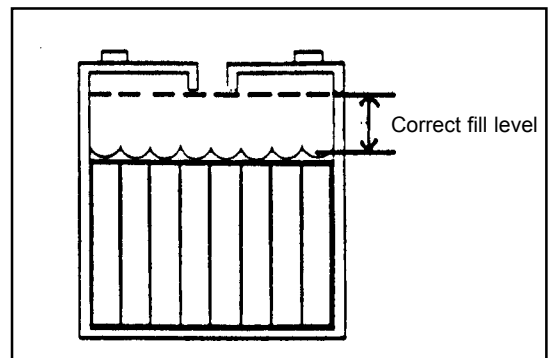

Figure #10

2. Keep the tops of the batteries clean and dry. Keep the terminals and connectors clean. To clean the top of the batteries, use a damp cloth with a weak solution of ammonia or bicarbonate of soda solution. To clean the terminals and connectors, use a terminal and connector cleaning tool. Do not allow ammonia or bicarbonate of soda to get into batteries.
3. Keep the batteries charged.

HOW TO PREPARE THE MACHINE FOR OPERATION

How To Charge The Batteries

- ⚠ WARNING:** Charging the batteries in an area without adequate ventilation could result in an explosion. To prevent an explosion, charge the batteries only in an area with good ventilation.
- ⚠ WARNING:** Lead acid batteries generate gases which could explode. Keep sparks and flames away from batteries. **NO SMOKING!**
- ⚠ WARNING:** Failure to disconnect the AC plug from the wall receptacle before connecting or disconnecting the DC connector on the charger could result in an explosion. Always disconnect the AC plug from the wall receptacle before connecting or disconnecting the DC connector on the charger.

To charge the batteries, follow this procedure:

1. Put the charger on a flat surface. Make sure the vents on the sides are at least two inches away from walls and other objects. Make sure there are no objects near the vents on the bottom of the charger.
2. Make sure the key switch is in the "OFF" position.
3. Disconnect the battery pack connector from the control housing connector. See figure #11.
4. Connect the DC connector on the charger to the battery pack connector. See figure #12.
5. Connect the charger to a properly grounded single phase (3-wire) wall receptacle having the voltage, frequency, and ampere capacity specified on the nameplate of the charger.

For more instruction on the use of the charger, read the instruction book supplied with the charger.

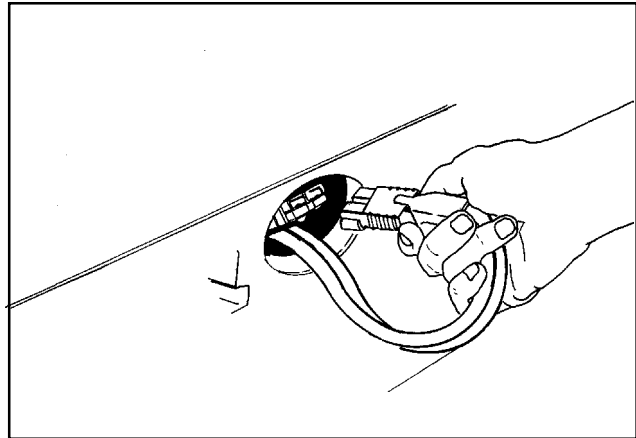

Figure #11

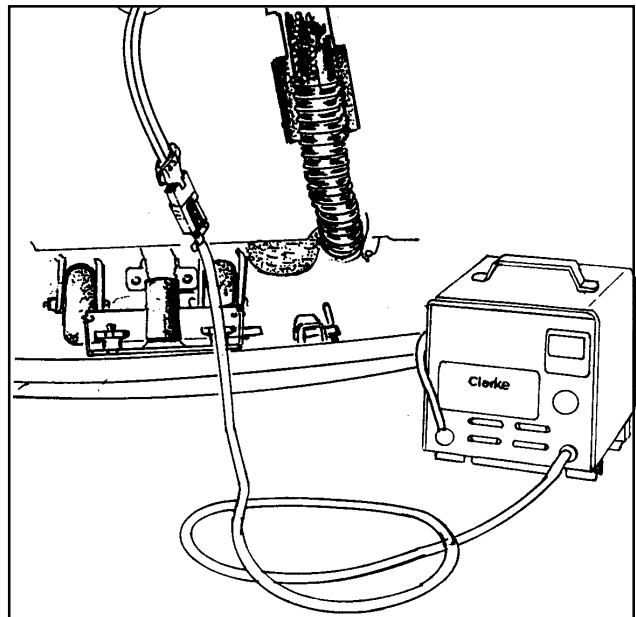

Figure #12

HOW TO PREPARE THE MACHINE FOR OPERATION

How To Install The Brushes Or Pad Drivers

To install the brushes or pad drivers on the machine, follow this procedure:

1. Turn the key switch "ON".
2. Put the brush switch in the "UP" position.
3. Turn the key switch "OFF".
4. Go to the front of the machine.
5. Unlatch right and left brush housings and remove them. See figure #13.
6. Put a brush or pad driver under the brush motor plate. See figure #14.
7. Align the lugs on the motor gimbal with the slots in the brush gimbal.
8. Pull the brush up until the gimbal locks.
9. Repeat steps 6, 7, and 8 to install the second brush or pad driver.

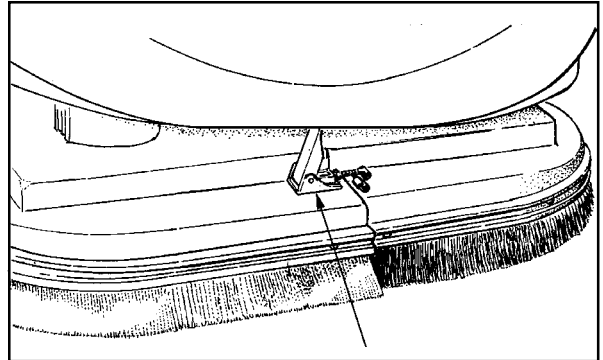

Figure #13

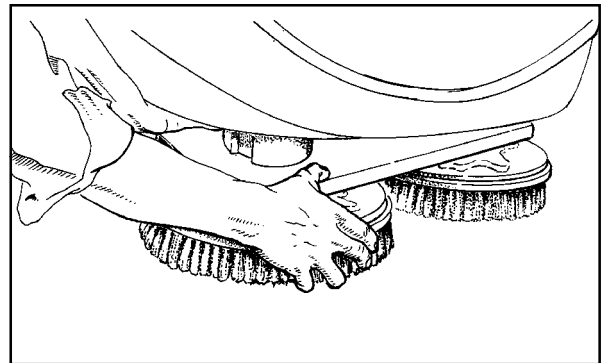

Figure #14

How To Remove The Brushes Or Pad Drivers

To remove the brushes or pad drivers from the machine, follow this procedure:

1. Turn the key switch "ON".
2. Put the brush switch in the "UP" position.
3. Turn the key switch "OFF".
4. Go to the front of the machine.
5. Push down on two sides of the brush or pad driver until the gimbals release.

HOW TO OPERATE THE MACHINE

How To Operate the Squeegee ("S Class" models only)

The squeegee wipes the floor while the vacuum motor removes the dirty solution from the floor. Use your right hand to lower or raise the squeegee handle. To operate the squeegee, follow this procedure:

1. To lower the squeegee and start the vac motor move the squeegee lever to the right and down. See figure #15.
2. To raise the squeegee, lift the squeegee lever up. See figure #16.

Note: The center position lets the vac motor continue to run with the squeegee off the floor to avoid drips.

How to Fill The Solution Tank

CAUTION: Make sure water or solution does not enter the opening for the vacuum motor See figure #17.

The solution tank lid is at the front. To fill the solution tank follow this procedure:

1. Remove the solution tank lid. See figure #18
2. Fill the solution tank with water.
3. Add a cleaning chemical to the water. for the correct amount, follow the directions shown on the container.

WARNING: Water solutions or cleaning materials used with this type of machine can leave wet areas on the floor surface. These areas can cause a dangerous condition for the operator or other persons. Always put CAUTION signs near the area you are cleaning.

WARNING: Machines can ignite flammable materials and vapors. Do not use with or near flammables such as gasoline, grain dust, solvents, and thinners. Only use a cleaning concentration recommended by the chemical manufacturer.

WARNING: Clarke Technology recommends a maximum water temperature of 120°F(49°C)

4. Replace the solution tank lid.

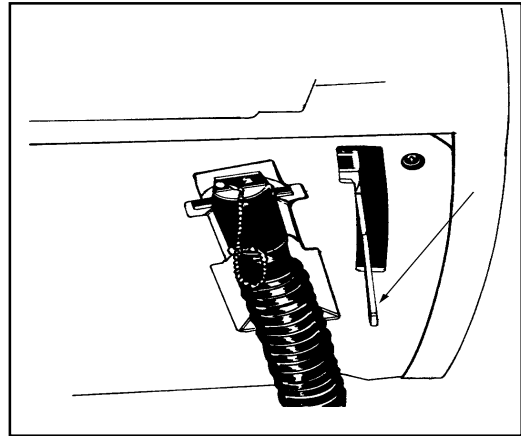

Figure #15

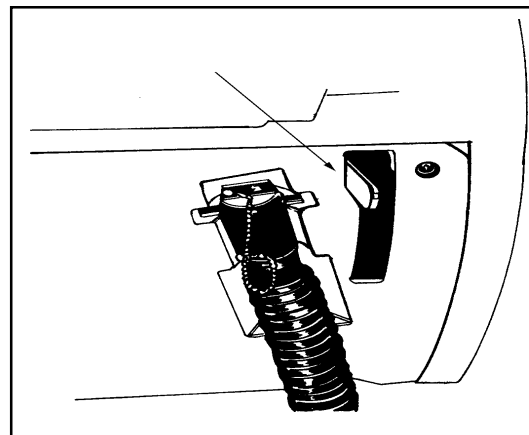

Figure #16

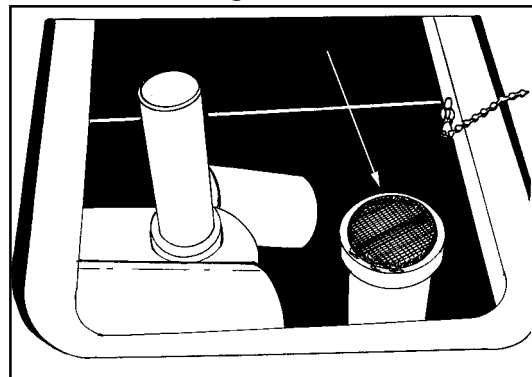

Figure #17

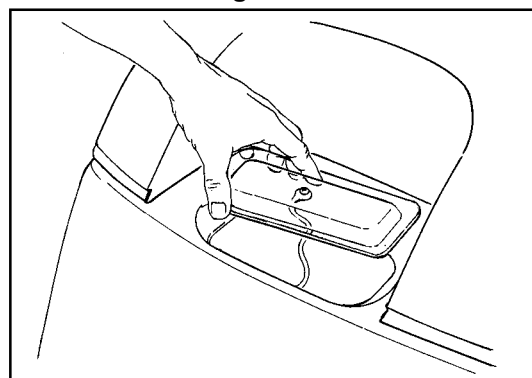

Figure #18

HOW TO OPERATE THE MACHINE (cont.)

NOTE: Put the machine in the slow traverse speed. Use the machine in an area that has no furniture and objects until you can do the following:

1. Move the machine in a straight direction, forward and backward.
2. Stop the machine safely.
3. Move the machine in a straight direction after you turn the machine.

To move the machine, follow this procedure:

1. Turn the key switch "ON" position.
2. Put the brush switch in the "UP" position.
3. Raise the squeegee.
4. To go forward, push the control handles toward the machine. See figure #19.
5. To stop the machine, put the handles in the center position.
6. To go backward, pull the handles away from the machine. See figure #20.
7. To turn the machine, push the rear of the machine to the side.
8. When you stop the machine, turn the key switch "OFF".

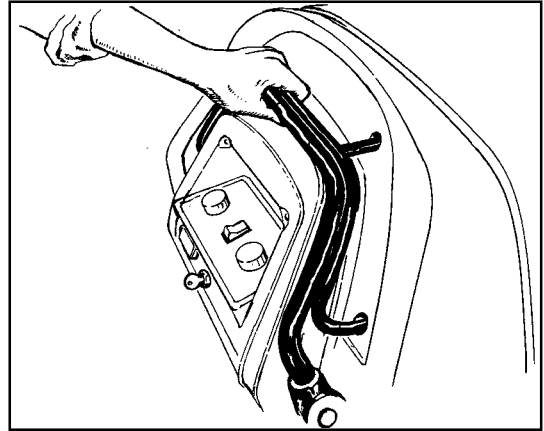

Figure # 19

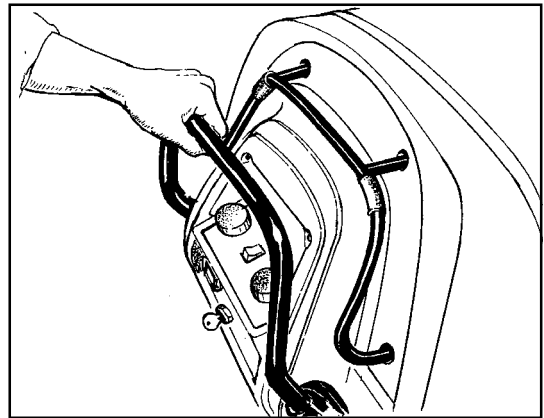

Figure #20

HOW TO OPERATE THE MACHINE (cont.)

HOW TO CLEAN A FLOOR

▲ WARNING: Water solutions or cleaning materials used with this type of machine can leave wet areas on the floor surfaces. These areas can cause a dangerous condition for the operator or other persons. Always put CAUTION signs near the area you are cleaning.

To clean a floor, follow this procedure:

1. Put the water and a cleaning chemical in the clean solution tank.
2. Turn the key switch "ON".
3. Lower the squeegee.
4. Put the brush switch in the "DOWN" position.
5. Turn the solution knob to the right to activate the flow of solution. Adjust the flow of clean solution to the flow desired.
6. Move the machine across the floor in the forward direction. See figure #21 (1).
7. When the machine is one machine length from the end of the area to be cleaned (figure #21 (2)), rotate the solution knob to the left.
8. Make a 180° turn. See figure #21 (3).

NOTE: When you make more passes across the floor, let the brushes clean approximately 2 inches of the area already cleaned by the brushes. See figure #21 (4).

NOTE: During most cleaning procedures, apply and remove the solution in one operation.

HOW TO CLEAN A VERY DIRTY FLOOR

To clean a very dirty floor, follow this procedure:

1. Apply solution to the floor.
2. Do not lower the squeegee.
3. Do not activate the vacuum motor.
4. Lower the brushes and scrub the floor.
5. Leave the solution on the floor long enough for the solution to begin cleaning the floor.
6. Scrub the floor again with additional solution, picking up all the solution with the squeegee

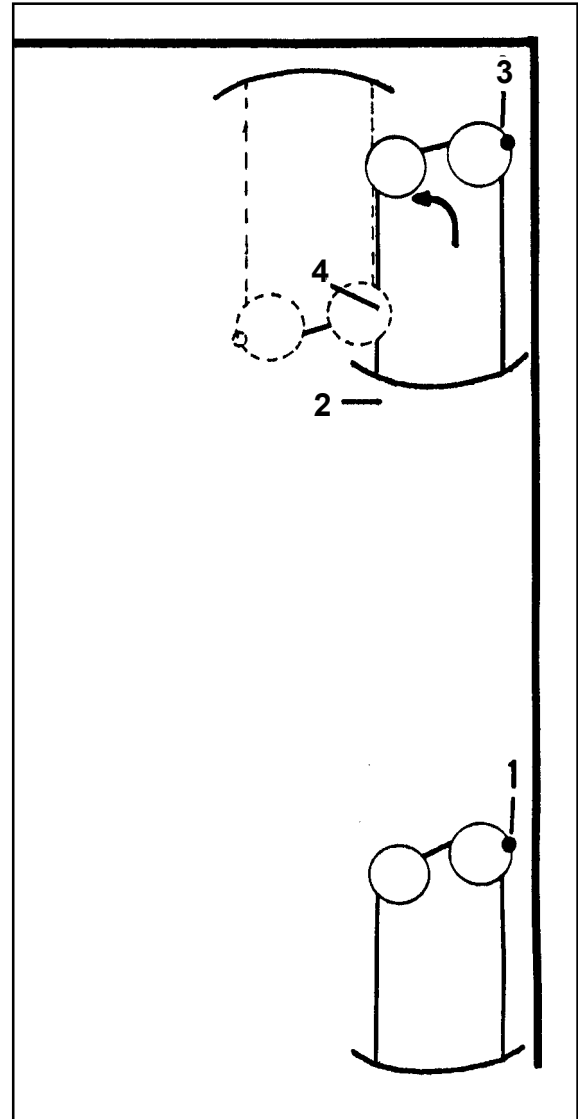

Figure #21

MAINTENANCE

⚠ WARNING: Maintenance and repairs must be done by authorized personnel only.

⚠ WARNING: Always empty the solution tank and recovery tank before doing any maintenance.

⚠ WARNING: Keep all fasteners tight.

These Maintenance Procedures Must Be Done Every Day

Keep the machine clean, it will need fewer repairs and have longer life.

Do These Procedures When You Begin Your Work Period

1. Turn off key switch.
2. Disconnect the plug on the charger from the connector on the back of the machine. See figure #22.
3. Join the connector from the batteries (1) to the control panel cable connection. See figure #22.
4. Make sure the recovery tank lid is on correctly. See figure #23, Item A.
5. Make sure the Screen filter over the vacuum motor is clean and in position. See figure #24, Item B.
6. Make sure the valves on the drain hoses are clean. Tightly close the valves.
7. Make sure brush housings and skirts are in position on the brush head.
8. Make sure the brushes are in position and installed correctly
9. Check the installation of the squeegee and squeegee hose.

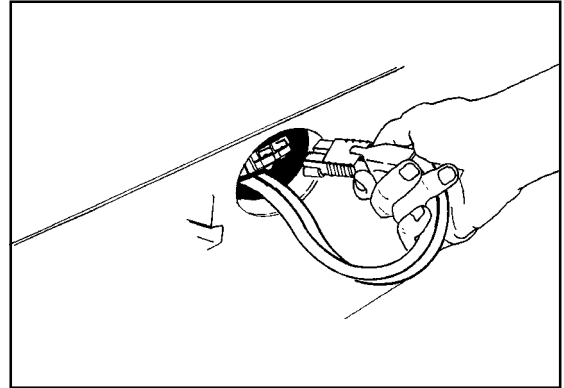

Figure #22

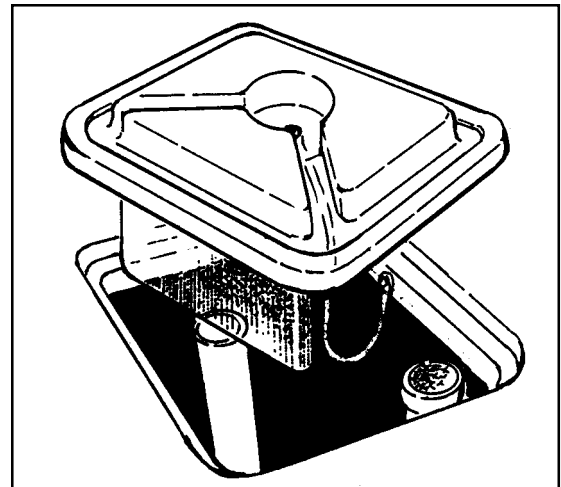

Figure #23

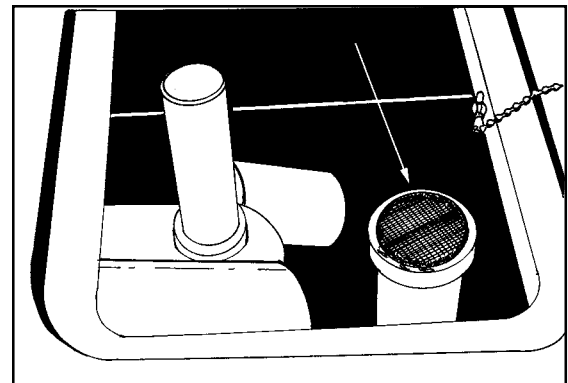

Figure #24

MAINTENANCE

Do These Procedures When You End Your Work

1. Drain the solution tank (Figure #25a) and the recovery tank (Figure #25b). To drain the tanks, follow this procedure:
2. Drain the solution tank (Figure #25a) and the recovery tank (Figure #25b). To drain the tanks, follow this procedure:
 - a. Turn the key switch "OFF".
 - b. Remove the drain hose from the back of the machine.
 - c. Put the end of the hose over a drain or bucket.
 - d. Turn the valve handle to the left. Pull the handle out to open the drain. (Figure #25c)

NOTE: Have the opening in the side of the valve away from you when you open the valve.

- e. To open the valve completely, turn the handle to the right. Pull the handle out of valve. (Figure #25d)
2. Flush the tanks. To flush the tanks, put clean water in the tank through the opening on top of the tank.
 3. If a tank or drain hose has an obstruction, use a high pressure water hose to flush the tank or hose. Put the water hose into the drain hose.
 4. Leave the tanks and the drain valves open to dry in the air.
 5. Check the squeegee blade. Use a cloth to clean the squeegee blade. If the squeegee blade is damaged or worn, turn or replace the blade.
 6. Check and clean the solution lid gasket. Use a mild cleaning solution and rinse the parts in clean water.

Check the batteries and add distilled water as needed. The correct level is within 1/4 inch of the bottom of the tube in each cell.

CAUTION: Tap water may contain contaminants that will damage batteries. Batteries must be re-filled with distilled water only.

WARNING: Lead acid batteries generate gases which can cause an explosion. NO SMOKING. Always wear eye protection and protective clothing when working near batteries.

Use a clean cloth and wipe the surface of the machine.

Charge the batteries. See the instruction in the section of this book called "How To Charge The Batteries".

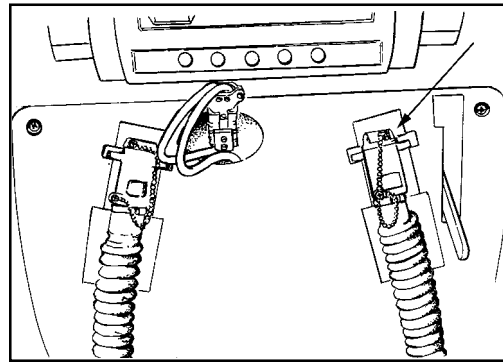

Figure #25a

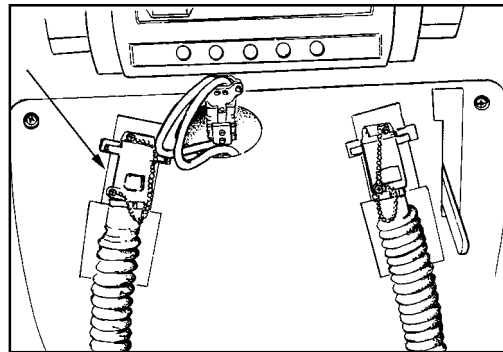

Figure #25b

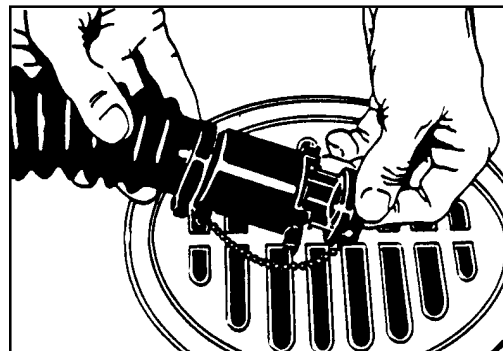

Figure #25c

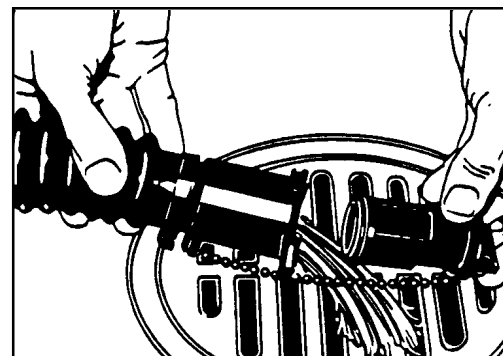

Figure #25d

MAINTENANCE

These Maintenance Procedures Must Be Done Every Week:

⚠ WARNING: Maintenance and repairs must be done by authorized personnel only. Always empty the solution tank and the recovery tank before doing any maintenance. Keep all fasteners tight.

⚠ WARNING: Always wear eye protection and protective clothing when working near batteries. Do not put tools or other metal objects across the battery terminals or the tops of the batteries.

⚠ CAUTION: To prevent damage to the machine, and discharge across the tops of the batteries, do not fill the batteries above the bottom of the tube in each cell. Wipe any acid from the machine or the tops of the batteries. Do not add acid to battery after installation.

NOTE: Always turn off key switch before servicing the machine.

⚠ WARNING: Always wear eye protection and protective clothing when working near batteries. **NO SMOKING!**

1. To inspect batteries, tip up recovery tank until it locks in up position. See Figure #26.
2. Disconnect the batteries. Use a cloth and a solution of ammonia or bicarbonate of soda to wipe the top of the batteries. Clean the battery terminals. Reconnect the batteries.
3. Check the hoses for leaks, obstructions and other damages.
4. Check and clean the filter screen in the solution hose. To clean the screen, follow this procedure:
 - a. Turn the connector to the left.
 - b. Remove and clean the filter screen.
 - c. Install the filter screen in the hose. Turn the connector to the right to connect the hose.
5. Use a grease gun to lubricate the drive wheel and the casters. See figure #27.
6. Check tire pressure. Tire pressure should be about 50 psi.

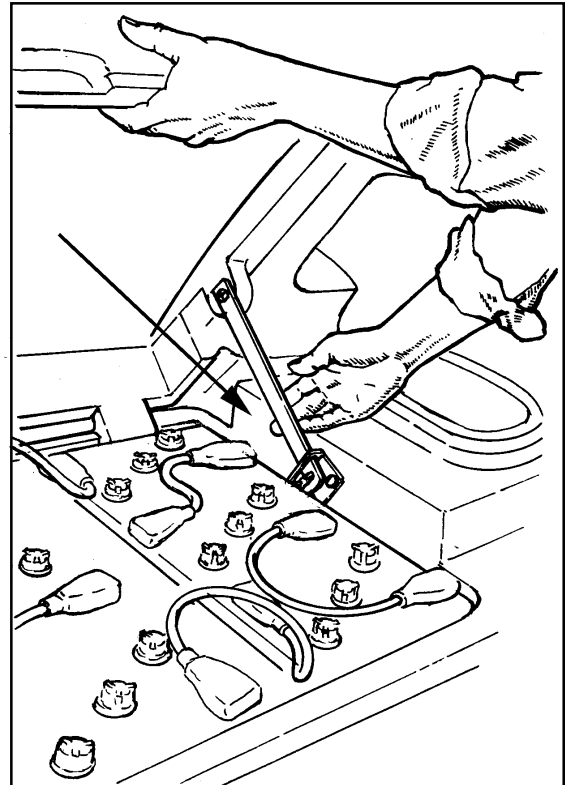

Figure #26

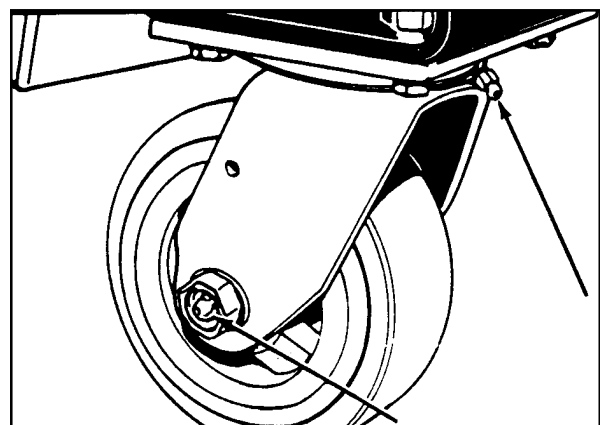

Figure #27

MAINTENANCE

7. Check the squeegee and the scrub brushes or the pad drivers for damage.
8. Check the squeegee and the vacuum hose for damage, leaks and obstructions.

Maintenance For The Squeegee

To remove the squeegee, follow this procedure:

1. Remove the squeegee assembly by loosening the two knobs that attach the squeegee to the machine. Pull the squeegee assembly off. See figure #28.
2. Inspect the squeegee blade.
3. If the blade is worn, turn the blade so that a new edge is in the wiping position.
4. Reinstall squeegee assembly on the machine.

How To Adjust The Squeegee

The following adjustments are set at the factory, however they may require slight adjustment.

Adjusting Squeegee Pressure:

To adjust the pressure, refer to Figure #29. Proper adjustment will produce a uniform flare along the rear blade when the machine is moved forward. To increase pressure, tighten the nuts on each side of the swing arm. To decrease the pressure, loosen the nuts on each side.

Adjusting Squeegee Tilt:

The tilt of the squeegee causes the rear blade to raise up in the center or on the ends, depending on which direction the tilt is changed. For tilt adjustment, refer to figure # 30. Loosen left and right screw "X". In order to bring the rear blade down in the center, tip "Y" down. To bring both ends down, tip "Y" up. Make very small adjustments and try it until a uniform flare is achieved. Changing the tilt may also require readjusting the squeegee pressure.

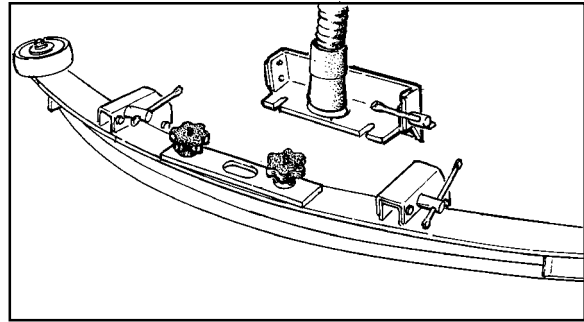

Figure #28

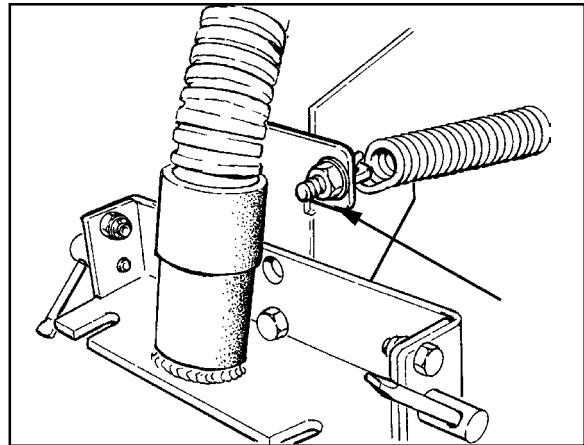

Figure #29

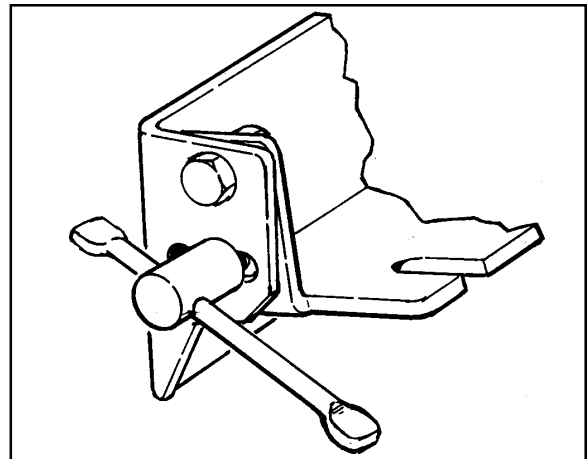

Figure #30

MAINTENANCE

Adjusting Squeegee Blades

When properly installed the front blade should be approximately .06 above the rear blade. See figure #31.

Adjusting Squeegee Support Wheels:

The support wheels should be set at .12 above the floor with the rear blade touching the floor. See figure #31.

⚠ WARNING: Maintenance and repairs must be done by authorized personnel only .

⚠ WARNING: Electrical repairs must be done by authorized personnel only.

Consult your Clarke Technology Authorized Service Person to do the service procedures.

Use only genuine Clarke Technology parts.

How to Clean the Solution Line

If the solution line becomes clogged, pull the filter assembly out from behind the brush housing (Figure #32) and remove the filter screen (Figure # 33) and clean or replace it. Push filter assembly back inside frame.

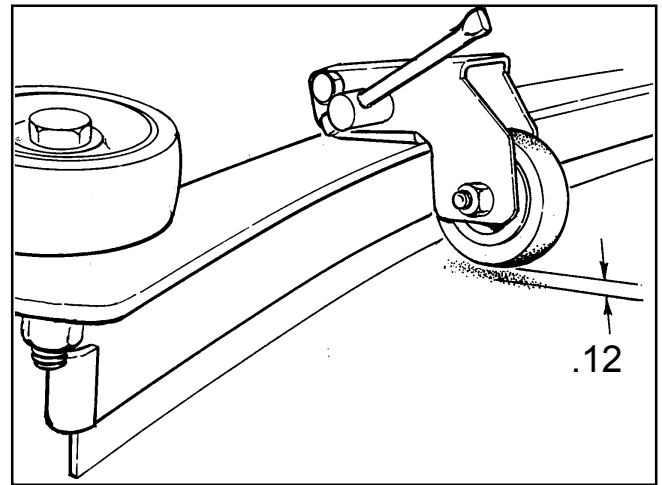

Figure #31

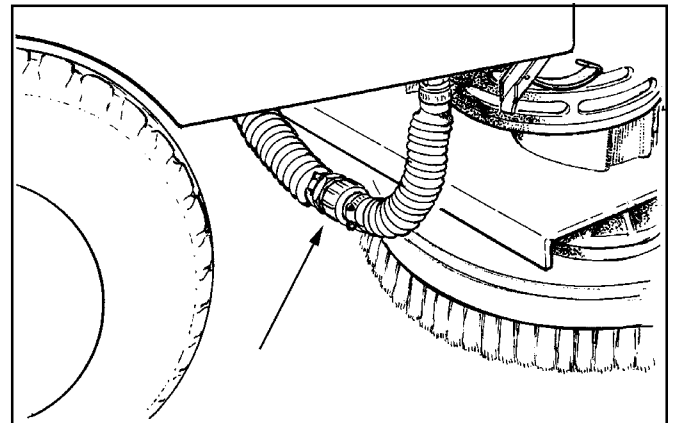

Figure #32

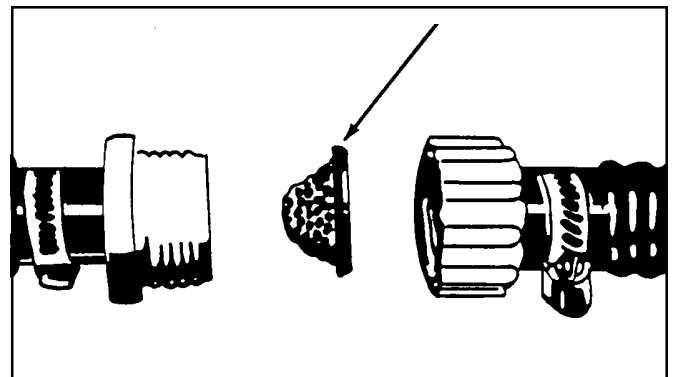

Figure #33

**Clarke Technology Encore 28/33/38
Accessories - 6/99**

ACCESSORIES

Description	Part No.
Power Wand System Kit	10674A
ESP Recycle System Kit	10675A
Soft Caster Asm.	52127A
Clarke Technology Care Kit	14607A
Squeegee Asm., Optional 29" (28 model only)	18818A
Drive Wheel, Foam Filled	59955A
<i>Stature</i> Electric Parking Brake Kit	10676A
<i>Imperial</i> Electric Parking Brake Kit	10684A

Optional Squeegee Blades

Machine	Blade	Type	Material	Length	Part No.
28	Inner	Optional	Urethane, Ribbed (60)	25.88"	30951A
28	Inner	Optional	Urethane, Notched, 1/16" (80)	25.88"	30955A
28	Inner	Optional	Urethane, Ribbed (60)	35.88"	30952A
28	Inner	Optional-Grout	Urethane, Notched 1/16" (80)	35.88"	30957A
33	Inner	Optional	Urethane, Ribbed (60)	40.25"	30953A
33	Inner	Optional-Grout	Urethane, Notched 1/16" (80)	41.00"	30958A
38	Inner	Optional	Urethane, Ribbed (60)	46.00"	30954A
38	Inner	Optional-Grout	Urethane, Notched, 1/16" (80)	46.00"	30959A
28	Outer	Optional	Nitrile, Solid (40)	28.12"	30938A
28	Outer	Optional	Nitrile, Solid (40)	38.50"	30936A
33	Outer	Optional	Nitrile, Solid (40)	42.12"	30937A
38	Outer	Optional	Nitrile, Solid (40)	48.00"	30939A

Brushes:

Size	Description	Part No.
17"	Poly	11424B
17"	Grit-Heavy	11425B
17"	Grit-Medium	11430B
17"	Soft Nylon	11428B
14"	Poly	11427B
14"	Grit-Heavy	11426B
14"	Grit-Medium	11431B
14"	Soft Nylon	11429B
19"	Poly	11434B
19"	Grit-Heavy	11433B
19"	Grit-Medium	11432B
19"	Soft Nylon	11435B

Pad Drivers:

Size	Part No.
19"	17524B
17"	17520C
14"	17521C

Manual Numbers for Translations:

Part No.	Description	Part No.	Description	Part No.	Description
79049B-FR	French	79049B-DK	Danish	79049B-DE	German
79049B-ES	Spanish	79049B-NL	Dutch	79049B-SE	Swedish
79049B-NO	Norwegian	79049B-CZ	Czk	79049B-IT	Italian
79049B-PT	Portuguese	79049B-FI	Finnish		



CLARKE

TECHNOLOGY

Encore

S28/L28/S33/L33/S38/L38

Section II

Parts and Service Manual

(79049B)

HOW TO CORRECT PROBLEMS IN THE MACHINE

PROBLEM	CAUSE	ACTION
<p>The machine does not remove all the water from the floor.</p>	<p>The squeegee is up</p> <p>The vacuum tank is full.</p> <p>The screen filter is dirty.</p> <p>There is an obstruction or damage in the squeegee, squeegee hose or standpipe.</p> <p>The vacuum motor is not running.</p> <p>The squeegee hose is disconnected.</p> <p>The squeegee blade is damaged, worn, or incorrectly installed.</p> <p>The squeegee pressure is not correctly adjusted.</p> <p>The gaskets on the cover of the recovery tank are damaged.</p>	<p>Lower the squeegee.</p> <p>Drain the tank.</p> <p>Clean the screen filter.</p> <p>Remove the obstruction or repair the damage.</p> <p>Check for tripped breaker. Have an authorized service person make repairs.</p> <p>Connect the hose.</p> <p>Turn or replace the squeegee blade. Correctly install the squeegee blade.</p> <p>Adjust the pressure of the squeegee.</p> <p>Replace the gaskets.</p>
<p>The batteries do not give the normal running time.</p>	<p>The battery terminals are dirty or damaged.</p> <p>The electrolyte level is too low.</p> <p>The batteries are not fully charged.</p> <p>The charger is damaged.</p> <p>The battery is defective.</p> <p>The batteries are disconnected.</p>	<p>Clean the terminals and connectors. Replace the damaged cables. Charge the batteries.</p> <p>Add distilled water to each cell and charge the batteries.</p> <p>Charge the batteries for a full 16 hour charge.</p> <p>Have an authorized service person repair the charger.</p> <p>Check voltage of each cell while discharging.</p> <p>Connect the batteries.</p>
<p>The cleaning is not even.</p>	<p>The scrub brushes or pads are worn.</p> <p>There is damage to the brush assembly, casters or the solution valve.</p> <p>The brush motors are not running</p> <p>The solution level is low.</p>	<p>Replace the scrub brushes or pads.</p> <p>Have an authorized service person make the needed repairs.</p> <p>Check for tripped breaker, reset. Check for loose connections.</p> <p>Fill the solution tank.</p> <p>NOTE: If the motors continue to stop consult an authorized service person.</p>
<p>The machine does not run.</p>	<p>The machine loses power.</p>	<p>Reset the circuit breaker.</p> <p>Check wire connection to traverse motor.</p> <p>Replace the fuses.</p> <p>Check the batteries connections.</p> <p>Check parking brake override lever position (if installed)</p> <p>NOTE: If the motors continue to stop, consult an authorized service person.</p>

MAINTENANCE

Adjusting Brush Head Position Switch: (See figure 34)

1. Turn "ON" the key switch.
2. Start with the brush head up/down switch in the "Up" position and the brush pressure knob set to minimum, fully counter clockwise. This should cause the brush head to be in the full "Up" position.
3. Install the proper brushes or pads and pad drivers for the machine.
4. Leave the brush pressure knob set to minimum, fully counter clockwise. Switch the brush head up/down switch to the "Down" position. This should cause the brush head to travel down to the floor until the brush position switch (47422A) is closed. At this time the brush head actuator will stop running down.
5. Check at the front of the machine to see if the brushes or pads are completely flat on the floor. The screw, that goes through the brush head actuator tube (69188A), should be at the top of the 1.25 inch slot in the tube. If the brushes or pads are not on the floor, or the screw is not at the top of the slot, the brush position switch (47422A) needs to be loosened and moved up or down in the slot on the switch mount bracket (65972A). Retighten the brush position switch.
6. Keep the brush pressure knob set to minimum, fully counter clockwise. The brush head will need to be raised and lowered again with the brush up/down switch. Check to see if the adjustment put the brushes or pads on the floor and kept the screw at the top of the tube. If no, repeat step #5 until this step is completely accomplished.

Replacing a Defective Brush Head Hall Affect Sensor (L Series only)(See figure 35)

1. Remove the brush head actuator assembly from the machine.
2. Loosen the locking nut on the brush head hall affect sensor at the top of the brush head actuator.
3. Unscrew the brush head hall affect sensor (Part Number 46742A) from the top of the brush head actuator.
4. Screw in the new brush head hall affect sensor into the top of the brush head actuator until it touches the metal disk on the motor gear. Unscrew the brush head hall affect sensor from the top of the brush head actuator three (3) complete turns.
5. Using the supplied jam nut, lock the brush head hall affect sensor down using loctite thread locker.
6. Reinstall the brush head actuator assembly on the machine.

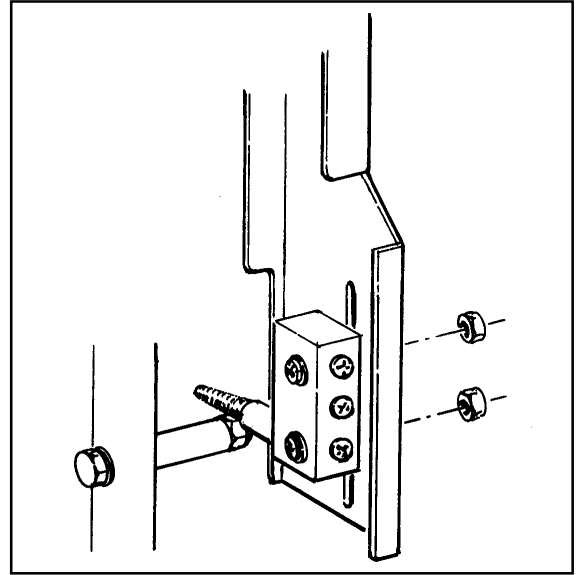

Figure #34

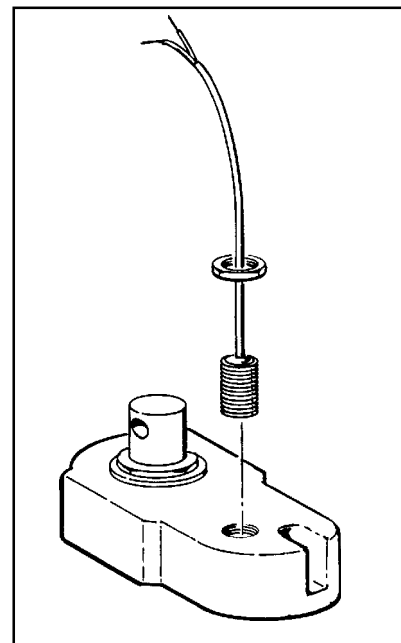
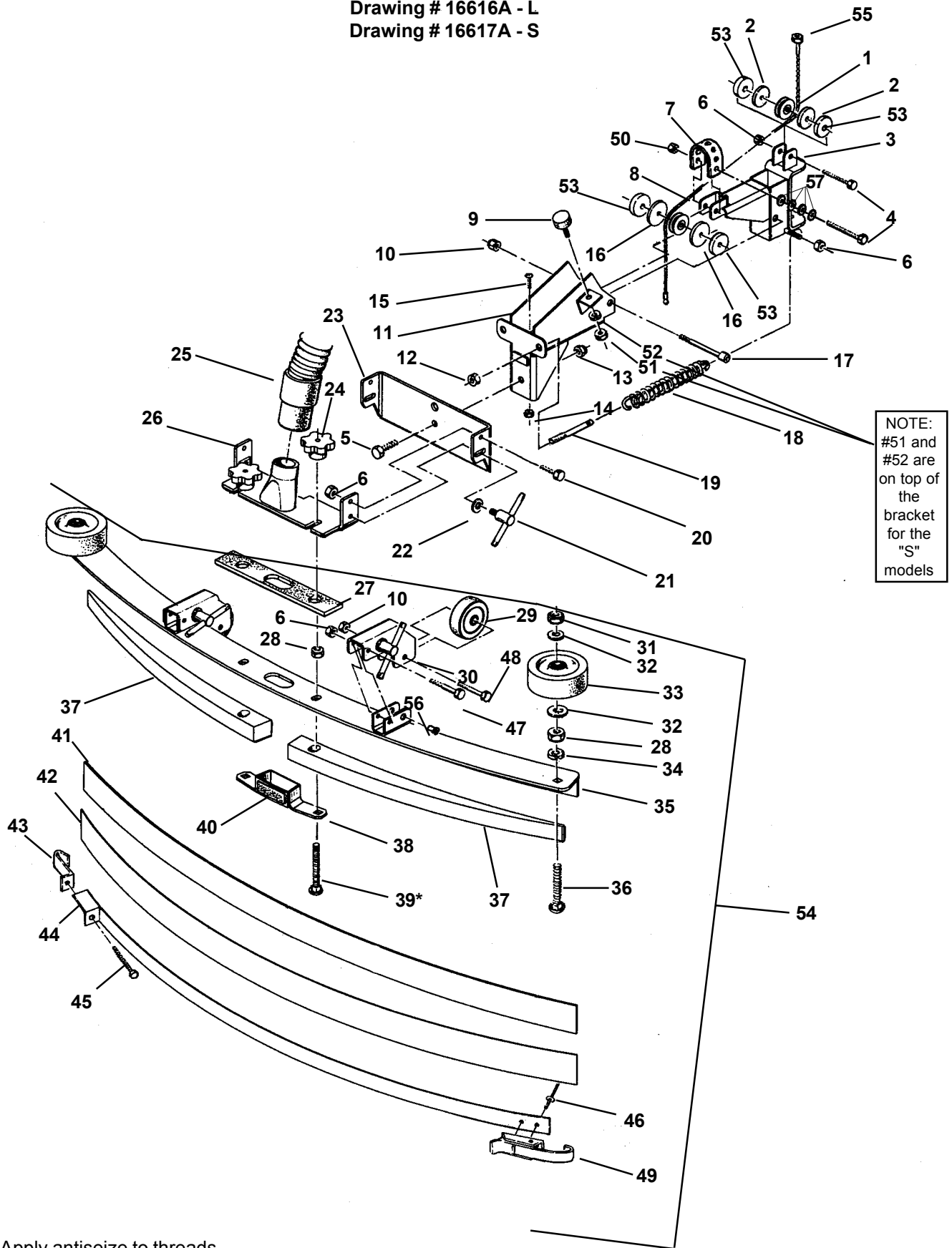

Figure #35

CLARKE TECHNOLOGY Encore S28/S33/S38 and L28/L33/L38
 Squeegee/Swing Arm Assembly Drawing 11/99
 Drawing # 16616A - L
 Drawing # 16617A - S



* Apply antiseize to threads

**CLARKE TECHNOLOGY Encore S28/S33/S38 and L28/L33/L38
Squeegee/Swing Arm Assembly Parts List 11/99**

Ref #	Part No.	Description	Qty	Model
1	57275A	Pulley	2	All
2	87623A	Washer, Nylon 1/4x1/4x1/8	2	All
3	60452A	Swing Arm, Front	1	All
4	86004A	Screw, .25-20 x 1.50	2	All
5	85727A	Screw, .375-16 x 1.00	1	All
6	81104A	Nut, Hex ESNA SS	6	All
7	38021A	Strap	1	All
8	61679A	Cable, Lower	1	All
9	51613A	Bumper	1	All
10	920110	Nut, ESNA	3	All
11	60454A	Swing Arm, Rear	1	All
12	920256	Nut, Hex	2	All
13	81105A	Nut, ESNA SS	1	All
14	920296	Nut, 10-24 ESNA SS	1	All
15	962798	Screw, 10-24 x .50	1	All
16	87624A	Washer, Nylon 1/2x1/4x1/8	2	All
17	80015A	Screw, Shoulder	1	All
18	53423A	Spring, Squ. Pressure	2	All
19	68016A	Stud	2	All
20	170915	Screw, SS Hex	2	All
21	64905A	T Handle	3	All
22	980651	Washer, Flat .312	1	All
23	60678A	Pivot Bracket	1	All
24	25201A	Knob	2	All
25	35192A	Hose, Squeegee Rec.	1	All
26	61267A	Tube Bracket	1	All
27	34260B	Squeegee Gasket	1	All
28	81301A	Nut, Jam SS	4	All
29	59971A	Wheel	2	All
30	65975A	Wheel Mount Bracket	2	All
31	920248	Nut, Jam	2	All
32	980645	Washer, Flat	4	All
33	59950A	Guide Wheel	2	All
34	980638	Washer, Lock	2	All

NOTE: When changing squeegee blades, it might be necessary to loosen screw #39; install and secure blades with clamp #44; then retighten screw #39. This will allow for different thickness.

Ref #	Part No.	Description	Qty	Model
35	69673A	Squeegee Base	1	28
	69674A	Squeegee Base	1	33
	69675A	Squeegee Base	1	38
	69636A	Squeegee Base, 29" acc.	1	28
36	85610A	Screw, PN Phillips	2	All
37	38710A	Spacer	2	28
	38711A	Spacer	2	33
	38715A	Spacer	2	38
	38713A	Spacer, 29" accessory	2	28
38	62712A	Air Duct	1	All
39	80011A	Screw, .375-16 x 3.00	2	All
40	37016A	Grip Pad	1	All
41*	30914A	Blade, Inner	1	28
	30915A	Blade, Inner	1	33
	30934A	Blade, Inner	1	38
	30930A	Blade, Inner Ribbed 29"	1	28
42*	30912A	Blade, Outer	1	28
	30913A	Blade, Outer	1	33
	30935A	Blade, Outer	1	38
	30931A	Bade, Outer 29" acc.	1	28
43	62421A	End Clamp	1	All
44	62442A	Clamp, Weld	1	28
	62443A	Clamp, Weld	1	33
	62444A	Clamp, Weld	1	38
	62441A	Clamp, Weld 29" acc.	1	28
45	86004A	Screw, .25-20 x 1.50 Hex	1	All
46	170932	Rivet	2	All
47	85702A	Screw, .25-20 x 1.75	2	All
48	85816A	Screw, .312-18 x 1.75	2	All
49	55722A	Squeegee Strap Latch	1	All
50	81217A	Nut, 1/2-20	1	All
51	920208	Nut, Hex 1/4-20	1	All
52	980657	Washer, 1/4 Lock	1	All
53	87625A	Washer, Nylon 1/4x1/4x1/32	4	All
54	18815K	Asm., Squeegee	1	28
	18816K	Asm., Squeegee	1	33
	18817K	Asm., Squeegee	1	38
	18818A	Asm., Squeegee*	1	28
55	81303A	Nut, 1/4-28	1	All
56	54766A	Insert, Threaded 5/16-24	2	All
57	87026A	Washer	4	All

* See accessory page

CLARKE TECHNOLOGY Encore S28/S33/S38 and L28/L33/L38
Traverse System Assembly Drawing 12/00
Drawing 19021A

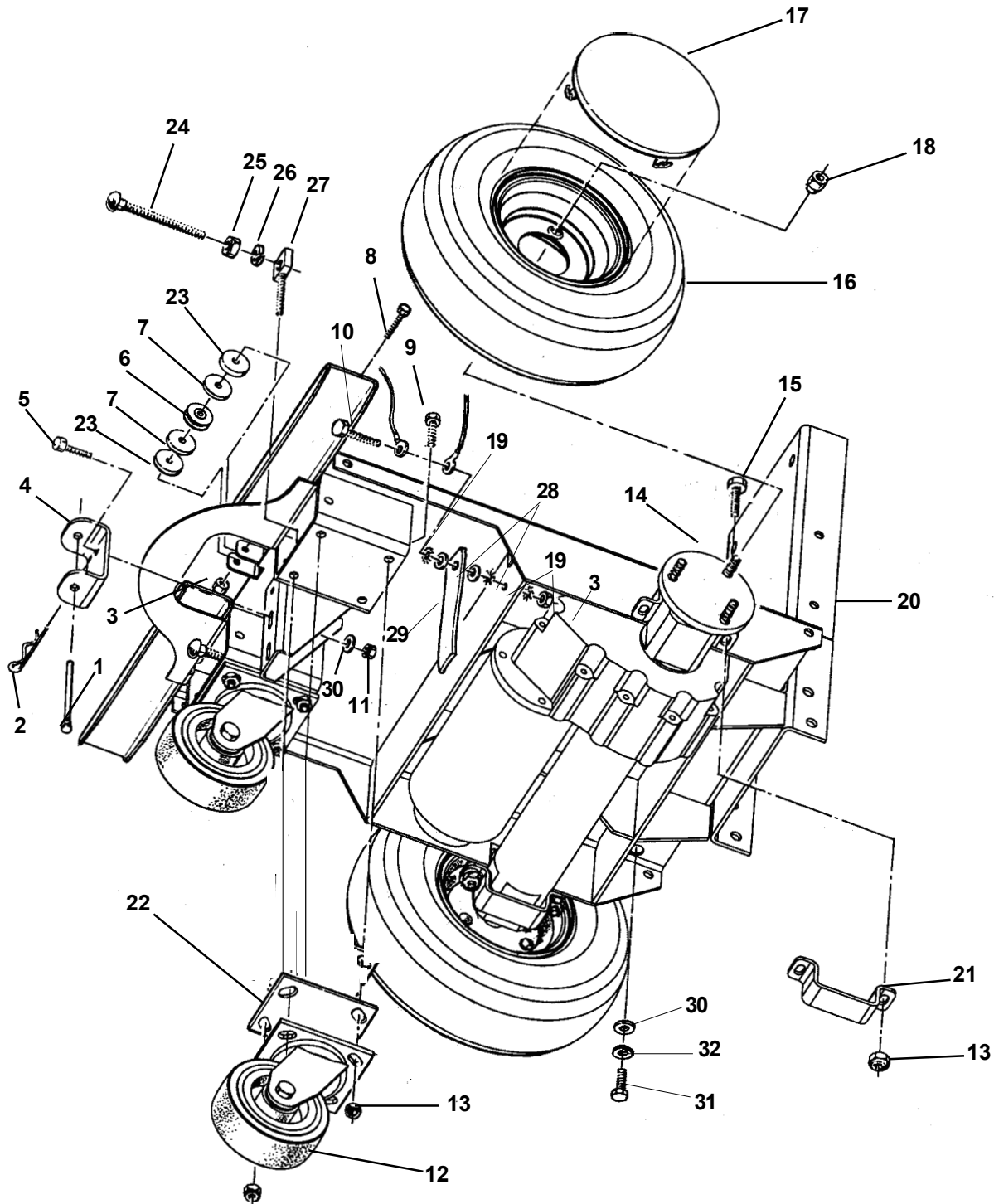

**CLARKE TECHNOLOGY Encore S28/S33/S38 and L28/L33/L38
 Traverse System Assembly Parts List 12/00
 Drawing 19021A**

Ref #	Part No.	Description	Qty	Model
1	66531A	Swing Arm Pin	1	All
2	836711	Hair Pin	1	All
3	81104A	Nut, .25-20 ESNA	2	All
4	69877A	Swing Bracket	1	All
5	85811A	Screw, .312-18 x .75	2	All
6	57275A	Cable Pulley	1	All
7	87623A	Washer, Nylon 1¼x¼IDx.120	2	All
8	86004A	Screw, .25-20 x 1.50	1	All
9	85703A	Screw, .375-16 x 1.50	6	All
10	85700A	Screw, .25-20 x 1	1	All
11	920110	Nut, .312-16 ESNA	2	All
12	899769	Caster Assembly	2	All
13	81105A	Nut, .375-16 ESNA	12	All
14	59116A	Transaxle, Imperial (see page 46, 45 for parts)	1	All
15	85730A	Screw, Hex	4	All
16	59969A	Wheel Assembly*	2	All
	59955A	Wheel, Foam Filled (opt.)	2	All
17	32417B	Wheel Cover	2	All
18	81221A	Lug Nut, 50-20 UNF	6	All
19	980614	Washer, Star Lock .25	3	All
20	60230A	Main Frame	1	All
21	65963A	Transaxle Mount	2	All
22	69712A	Spacer	2	All
23	87625A	Washer, Nylon 1¼x¼IDx3/32	2	All
24	80011A	Screw, ¾-16 x 3	2	All
25	81207A	Nut, ¾-16	2	All
26	170883	Washer, Lock ¾	2	All
27	58419A	Stud, ¾M x ¾F	2	All
28	980205	Washer, .25 Fender	2	All
29	69639A	Strap, Static	1	All
30	980645	Washer, Flat ¾	6	All
31	962244	Screw, ¾-16 x ¾	4	All
32	980638	Lockwasher ¾	4	All

*30039A tube, inner (included in item #16) 1 Ref.

CLARKE TECHNOLOGY Encore S28/S33/S38 and L28/L33/L38
Brush Head Assembly Drawing 7/00
Drawing # (i) 11453A, 11449A, 11452A
Drawing # (ix) 11448A, 11445A, 11450A

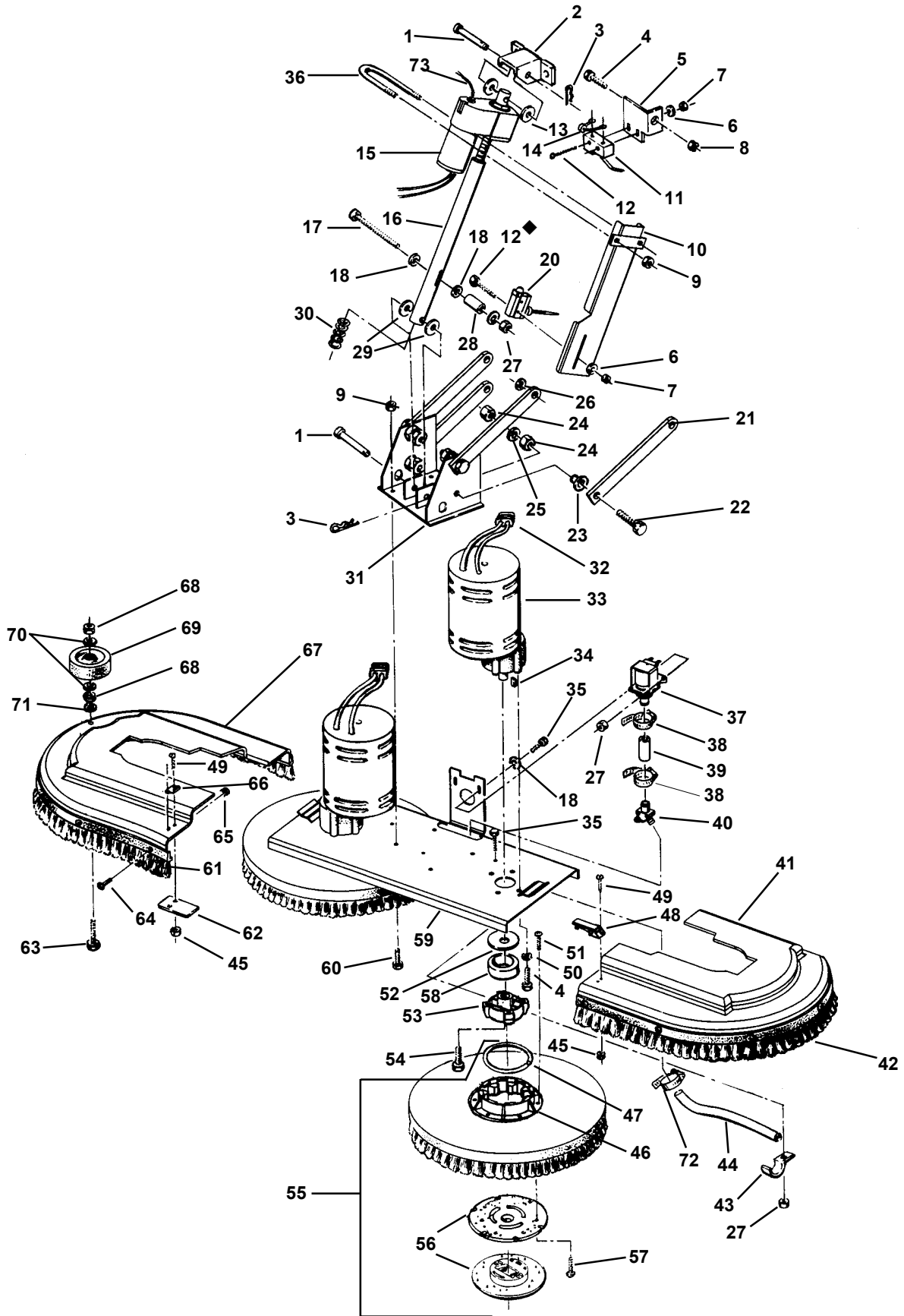

**CLARKE TECHNOLOGY Encore S28/S33/S38 and L28/L33/L38
Brush Head Assembly Parts List 7/00**

Ref #	Part No.	Description	Qty	Model
1	82501A	Pin	2	All
2	63433A	Main Frame	Ref	All
3	766780	Hair Pin	2	All
4	962244	Screw, .375-16x.75	9	All
5	69883A	Switch Bracket	1	All
6	980608	Washer, #6	4	All
7	920056	Nut, #6-32 ESNA	4	All
8	81105A	Nut, .375-16 ESNA	1	All
9	920110	Nut, .312-18 ESNA	6	All
10	65972A	Switch Mount	1	All
11	47374A	Lever, Switch	1	All
12	962980	Screw, #6-32x1.00 PN	4	All
13	38708A	Nylon Spacer	2	All
14	42401A	Diode	1	L series
15	50208A	Actuator & Tube Asm.	1	S series
	50209A	Actuator & Tube Asm. (includes item #73)	1	L series
16	69188A	Head Pressure Tube	1	All
17	85744A	Screw, .25-20x2.75	1	All
18	87007A	Washer, Flat .25	5	All
19				
20	47422B	Whisker Switch	1	All
21	63032A	Linkage Bar	4	All
22	85838A	Screw, .50-201.50	8	All
23	67705B	Sleeve Bearing	8	All
24	920278	Nut, Jam 50-20	16	All
25	980626	Washer, Lock .50	8	All
26	980673	Washer *	4	All
27	81104A	Nut, .25-20 ESNA	5	All
28	38725A	Sleeve	1	All
29	38723A	Nylon Spacer	2	All
30	53421A	Head Pressure Spring	1	L series
	53422a	Head Pressure Spring	1	S series
31	65966A	Brush Head Mount	1	All
32	41601A	Connector	4	All
	41602A	Housing	4	All
33****	45033A	Brush Motor .75 HP	2	S28/L28/S33
	45036A	Brush Motor 1.00 HP	2	L33/S38/L38
34	915102	Key	2	All
35	170915	Screw, Hex	4	All
36	80044A	"U" Bolt	1	All
37	48703A	Electric Valve	1	All
38	722030	Hose Clamp	2	All
39	30455A	Hose	1	All
40	38014A	Solution Splitter	1	All
41	35250B	Left Brush Housing	1	28
	35244B	Left Brush Housing	1	33
	35246B	Left Brush Housing	1	38
42	38242A	Left Skirt	1	28
	38244A	Left Skirt	1	33
	38246A	Left Skirt	1	38

Ref #	Part No.	Description	Qty	Model
43	782002	Clamp	2	All
44	30453A	Brush Hose	2	All
45	81109A	Nut, 8-32 ESNA SS	4	All
46	833802	Gimbal, Female	2	All
47	838301	Brush Holder Spring	2	All
48	55721A	Latch	1	All
49	962992	Screw, 8-32x.62 SS	4	All
50	980638	Washer, Lock .375	8	All
51	962495	Screw, .25-20x1.00Pn Hd	6	All
52	59856A	Rubber Washer	2	All
53	34400B	Gimbal, Male	2	All
54	962714	Screw, .312-18x.75 Soc.	2	All
55	11427B	Poly Brush Assembly-14	2	28
	11424B	Poly Brush Assembly-17	2	33
	11434B	Poly Brush Assembly-19	2	38
	11426B	Grit Brush Assembly-14	2	28
	11425B	Grit Brush Assembly-17	2	33
	11433B	Grit Brush Assembly-19	2	38
	17521C	Pad Driver Assembly-14	2	28
	17520C	Pad Driver Assembly-17	2	33
	17524B	Pad Driver Assembly-19	2	38
56	56941A	Center-Lok Asm. (Pad Driver Only)	2	All
57	962737	Screw, 10-16x.88 (Pad Driver Only)	6	All
58	61658A	Gimbal Collar	2	All
59	66232A	Brush Plate-28	1	28
	66233A	Brush Plate-33	1	33
	66234A	Brush Plate-38	1	38
60	85811A	Screw, .312-18x.75 Hex	4	All
61	38243A	Right Skirt	1	28
	38245A	Right Skirt	1	33
	38247A	Right Skirt	1	38
62	69186A	Latch Tab	1	All
63	85610A	Screw, .375-16x2.5 SS Pn	1	All
64	85616A	Screw, 10-22x.62 Pn SS	11	28
	85616A	Screw, 10-22x.62 Pn SS	12	33 38
65	82004A	"T" Nut 10-32	11	28
	82004A	"T" Nut 10-32	12	33 38
66	55451A	Keeper	1	All
67	30016A	Right Brush Housing	1	S28
	30017A	Right Brush Housing	1	L28
	30012A	Right Brush Housing	1	S33
	30013A	Right Brush Housing	1	L33
	30014A	Right Brush Housing	1	S38
	30015A	Right Brush Housing	1	L38
68	920248	Nut, .375-16 Jam Thin ESNA	2	All
69	59950A	Guide Wheel	1	All
70	980645	Washer, Flat .375	2	All
71	980638	Lockwasher	1	All
72	722021	Hose Clamp	2	All
73***	46742A	Brush Head Sensor	1	Lseries
**NI	77353A	Label, Front Motor	1	Sseries
**NI	77352A	Label, Front Motor	1	Lseries
**NI	77091A	Label, Moving Parts	2	All

*Used only as required to square up linkage bars #21 to the frame.

**Attach to Brush Motor.

***See page 27 for installation

****Includes Item #32

CLARKE TECHNOLOGY Encore S28/S33/S38 and L28/L33/L38
Solution/Recovery System Assembly Drawing 5/00

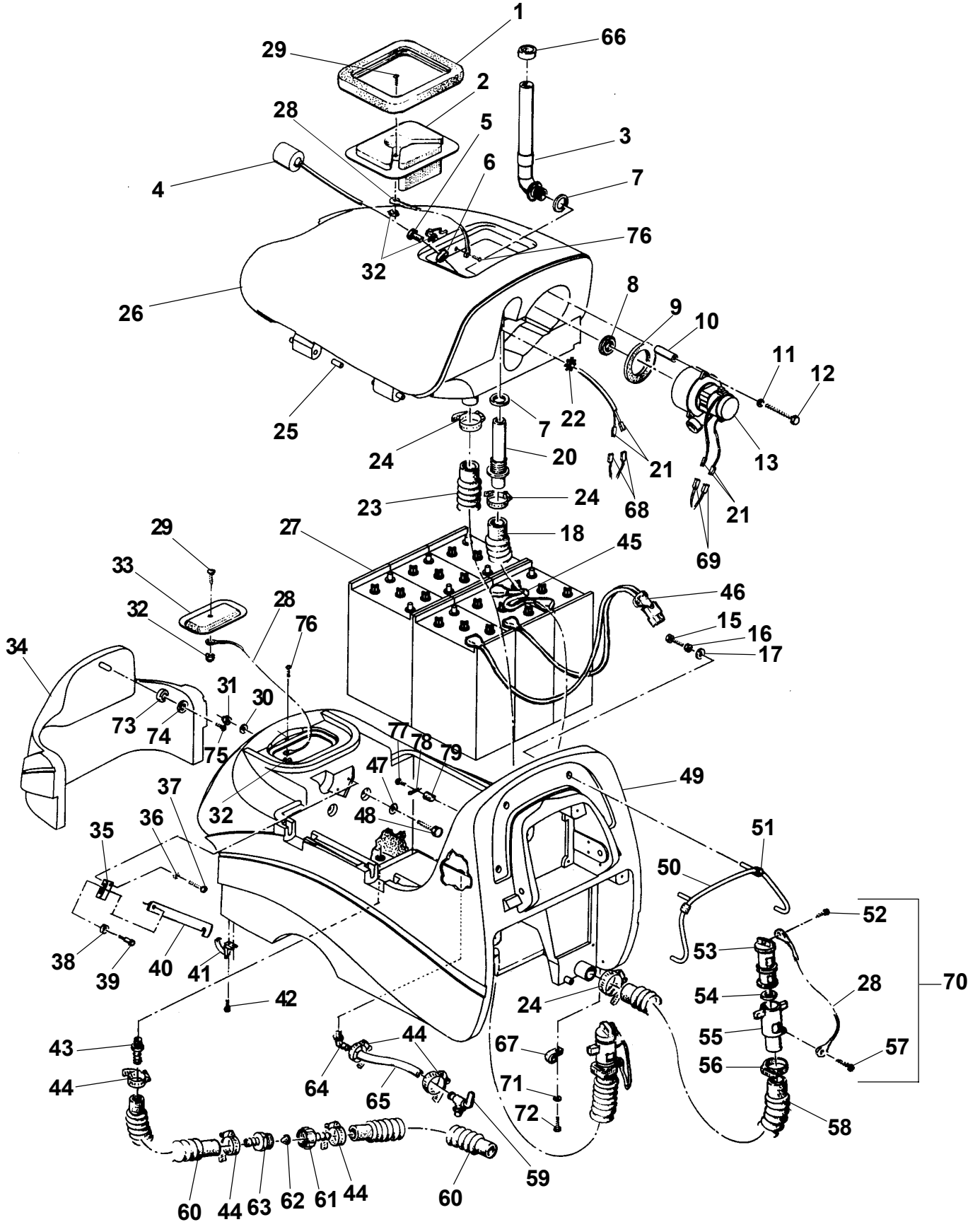

**CLARKE TECHNOLOGY Encore S28/S33/S38 and L28/L33/L38
Solution/Recovery System Assembly Parts List 5/00**

Ref #	Part No.	Description	Qty	Model
1	34265A	Recovery Lid Gasket	1	All
2	36204A	Recovery Lid	1	All
3	39338A	Stand Tube	1	All
4	40002A	Float Switch (include #5 & 2 each #21 & #68)	1	All
5	56459A	Strain Relief	1	All
6	87612A	Seal	1	All
7	837304	O-Ring	2	All
8*	920797	Nut	1	All
9	643418	Gasket	1	All
10	58533A	Vac Motor Spacer	3	All
11	87026A	Washer, Flat .25	3	All
12	85728A	Screw, .25-20 x 4.00 Hex	3	All
13	45019A	Vac Motor (also order 2 each #21 and #69)	1	All
14	77365B	Label, Battery Installation	1	All (NI*)
15	85815A	Screw, .312-18x1.25 Hex	4	All
16	980652	Washer, Lock .312	4	All
17	980205	Washer, Fender .312	4	All
18	35192A	Vac Hose	1	All
19	77093A	Label, Falling Parts	1	All (NI*)
20	30133A	Squeegee Adapter	1	All
21	41809A	Contact	4	All
22	82100A	Locknut	1	All
23	35165A	Recovery Tank Drain Hose	1	All
24	872010	Hose Clamp	3	All
25	36903A	Hinge Pin	4	All
26	38813C	Recovery Tank, incl #25	1	All
27	881317	Battery - 250 AH - 6 Volt	6	All
	891384	Battery - 330 AH - 6 Volt	6	All
	40704A	Battery - 370 AH - 6 Volt	6	All
28	38020A	Strap	4	All
29	962798	Screw, 10-24x.5 Pan	2	All
30	980645	Washer, Flat .375	2	All
31	81105A	Nut, .375-16 ESNA	2	All
32	920296	Nut, 10-24 ESNA	4	All
33	36200A	Solution Lid	1	All
34	32409B	Front Cover	1	28, 33
	32419B	Front Cover	1	38

*Recommended torque
175 ± 5 inch/ pounds.

(NI*) = Not Illustrated

Ref #	Part No.	Description	Qty	Model
35	69879A	Support Bracket	1	All
36	170892	Washer, Lock .25	2	All
37	170915	Screw, .25-20x.75 SS Hex	2	All
38	87622A	Washer, Nylon ⁵ / ₁₆ X ⁵ / ₈ X ¹ / ₃₂	1	All
39	80043A	Screw,Shoulder.25-20x25	1	All
40	69548A	Recovery Tank Support	1	All
41	55723A	Latch	2	All
42	962027	Screw, 8-32x.50 Pn.	4	All
43	50359A	Solution Tank Adapter	1	All
44	722030	Hose Clamp	6	All
45	842406	Series Cable - 9"	3	All
	41206A	Series Cable - 16"	2	All
46	41208A	Battery Cable	1	All
47	87054A	Washer,Fender .375x1¼	2	All
48	85703A	Screw, .375-16x 1.50 Hex	2	All
49	38812C	Solution Tank	1	All
50	64900A	Stationary Handle	1	All
51	30454A	Hose	2	All
52	962987	Screw, 10-24x.375 Pn.	2	All
53	833901	Drain Valve Handle	2	All
54	833407	Drain Gasket	2	All
55	839401	Drain Valve	2	All
56	832002	Hose Clamp, Drain Valve	2	All
57	962943	Screw, 8-18x.5 Pn.	2	All
58	30449A	Drain Hose	1	All
59	59614A	Battery Drain Valve	1	All
60	30445A	Solution Hose	2	All
61	50358A	Connector	1	All
62	838517	Filter Screen	1	All
63	830214	Hose Adapter	1	All
64	822802	Elbow	1	All
65	30453Au	Hose	1	All
66	58069A	Vac Filter	1	All
67	98465A	Clamp, Metal	1	All
68	43402A	Housing, Blue	2	All
69	43401A	Housing - Black	2	All
70	839410	Asm., Drain Valve	1	All
71	980657	Washer, ¼ Lock	1	All
72	962139	Screw, ¼-20x5/8	1	All
73	39713A	Washer, Rubber	1	All
74	87032A	Washer	1	All
75	85524A	Screw	1	All
76	962666	Screw	2	All
77	962113	Screw 10-32x1	1	All
78	51867A	Cable Clamp	1	All
79	81800A	Well Nut	1	All
80	77092A	Label, Gases & Chem.	1	All(NI*)

CLARKE TECHNOLOGY Encore S28/S33/S38 and L28/L33/L38
 Control Housing Assembly Drawing 7/00
 Drawing# 13712A (IX) and 13713A (I)

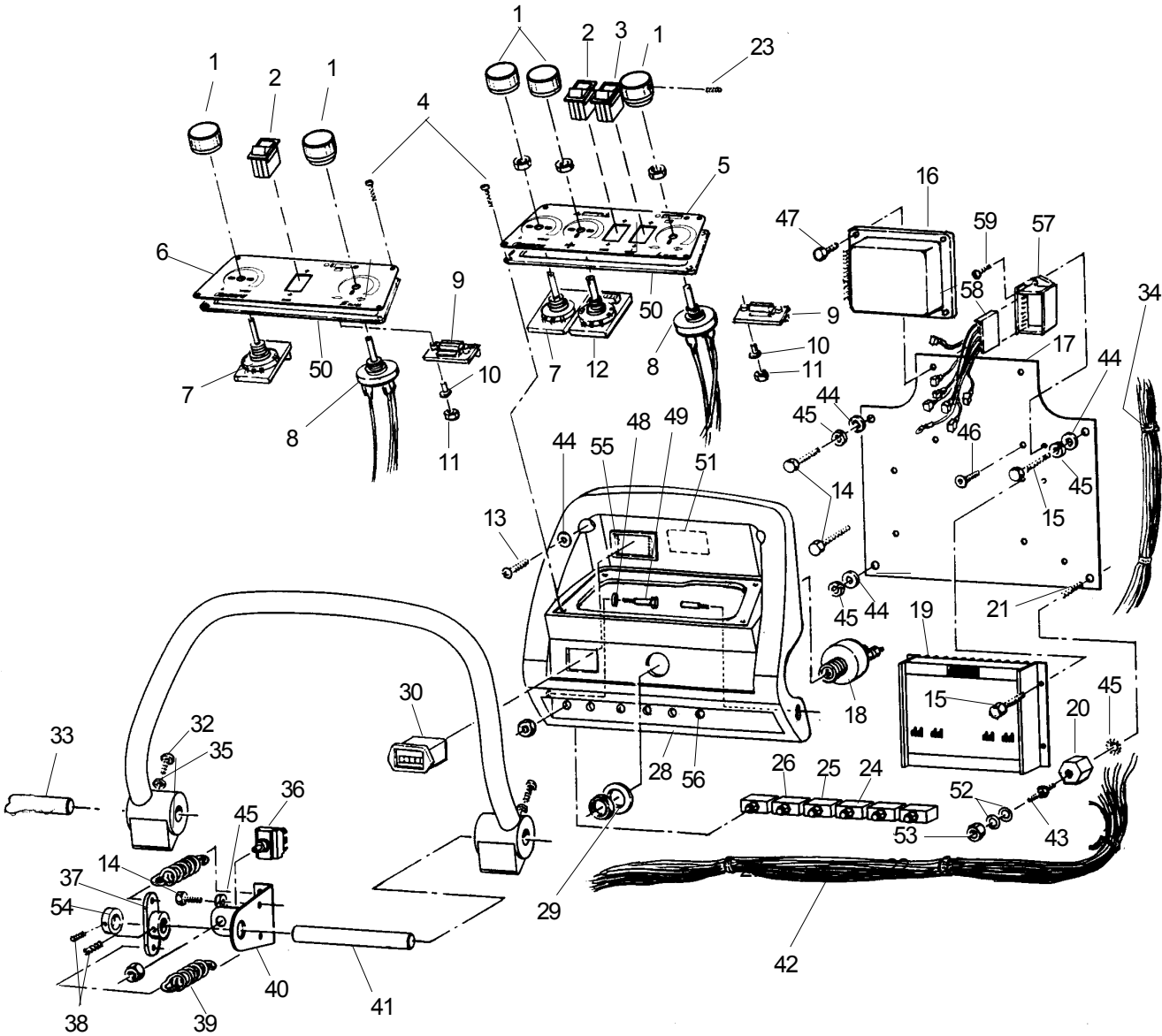

**CLARKE TECHNOLOGY Encore S28/S33/S38 and L28/L33/L38
Control Housing Assembly Parts List 7/00**

Ref #	Part No.	Description	Qty	Model
1	55502A	Knob	2	S series
	55502A	Knob	3	L series
2	47381B	Switch, Head up & down Rocker	1	All
3	47383A	Switch, Squeegee/Vac 3 Pos./Rocker	1	L series
4	85612A	Screw, 10-24 x .375 Pn.	6	All
5	77344B	Control Panel Label	1	L series
	60060A	Control Panel	1	L series
6	77343B	Control Panel Label	1	S series
	60058A	Control Panel	1	S series
7	44308A	Solution Flow Module	1	All
8	49700B	Speed Control Harness	1	All
9	44416B	Battery Meter	1	All
10	38724B	Spacer	2	All
11	920056	Nut, 6-32 ESNA	2	All
12	50170A	Head Pressure Adjustor	1	L series
13	85391A	Screw, .25-20 x .62 Pn	2	All
14	962139	Screw, .25-20 x .62	5	L series
	962139	Screw, .25-20 x .62	2	S series
	962992	Screw 8-32 x .75 Pn	4	L series
16	41153A	Head Pressure Control Board	1	L series
17	66241A	Upper Electrical Panel	1	L series
18	47380A	Key Switch	1	All
19	41154A	Actuator Control Board	1	L series
20	854849	Insulator	1	All
21	170781	Screw, 1/4-20 x 3/4 Set	1	All
22	41431A	Circuit Breaker 35A	2	All
23	962262	Screw, 8-32 x .25 Set	3	L series
	962262	Screw, 8-32 x .25 Set	2	S series
24	41448A	Circuit Breaker 30A Scr.	1	All
25	41422A	Circuit Breaker 25A Scr.	1	All
26	41423A	Circuit Breaker 5A	1	All
27	41430A	Circuit Breaker 1.5A	1	L series
28	35243B	Control Housing	1	L series
	35252B	Control Housing	1	S series
29	87052A	Nylon Washer, Key Switch	1	All
30	912226	Hour Meter	1	All
31	24309A	Control Handle	1	All
32	85390A	Screw, .25-20 x 1.25 Pn	2	All
33	66549A	Pin, Left Hand	1	All
34	49778A	Actuator, Control Harness	1	L series
35	170892	Washer, Lock .25	2	All
36	10052A	Toggle Switch	1	All
37	60662A	Centering Bracket	1	All
38*	962304	Screw, Set .312-18 x .5	4	All
39	53038A	Control Handle Spring	2	All
40	61266A	Control Bracket	1	All
41	66548A	Pin, Right Hand	1	All
42	49777A	Main Harness (L Series Only)	1	L series
	49779A	Main Harness (S Series only)	1	S series
43	83302A	Stud	1	All
44	87007A	Washer	2	S series
	87007A	Washer	5	L series
45	980657	Lock Washer	6	L series
	980657	Lock Washer	3	S series
46	54763A	Insert	8	L series
47	85613A	Screw, 8-32 x 7/8	4	L series
48	980651	Washer, Nylon IDxODx.034	1	All
49	80043A	Screw, Shoulder	1	All
50	30022A	Gasket, Panel	1	S series
	30025A	Gasket, Panel	1	L series
51	77350B	Label, Control Wiring	1	L series
	77351B	Label, Control Wiring	1	S series
52	87026A	Washer	2	All
53	81104A	Nut, 1/4-20 ESNA	1	All
54	61651A	Collar	1	All
55	66871A	Retainer Key/Hour Meter	1	All
56	60042A	Stud, 5/16 x 1/4-20 Thread	1	All
57	40083B	Module Sequencer	1	All
58	40085A	Harness, Sequencer	1	All
59	85388A	Screw, 10-24 x 1/2	2	L Series

*#38 must use red loctite set screws.

CLARKE TECHNOLOGY Encore S28/S33/S38 and L28/L33/L38
Rear Cover Assembly Drawing 5/00
Drawing 13712A & 13713A

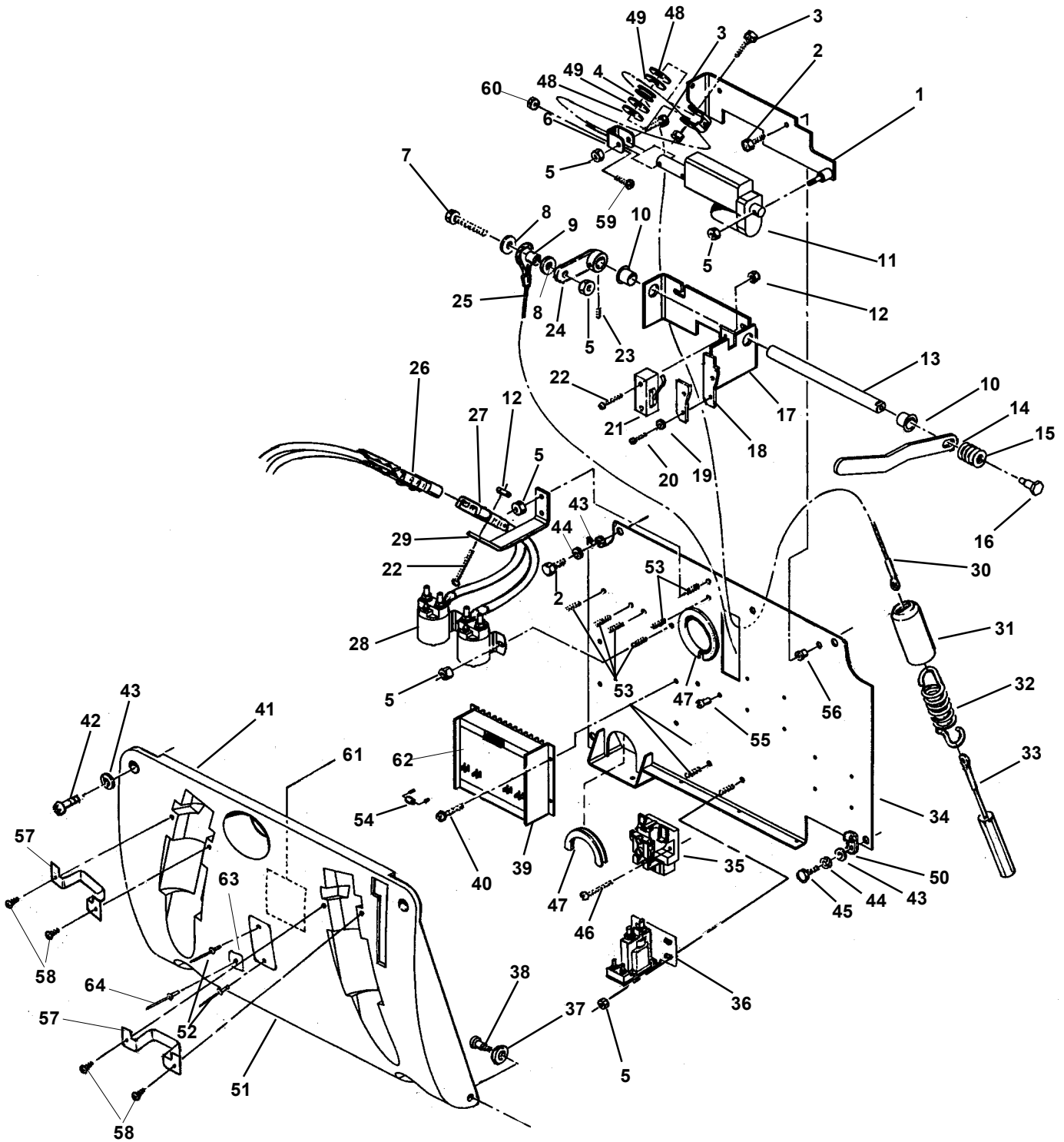

**CLARKE TECHNOLOGY Encore S28/S33/S38 and L28/L33/L38
Rear Cover Assembly Parts List 6/01**

*#23 must use red
loctite.

Ref #	Part No.	Description	Qty	Model
1	61264A	Actuator, Mount Bracket	1	L series
2	962139	Screw, .25-20x.62 Hex	5	All
3	86004A	Screw, .25-20x1.50 Hex	2	L series
4	57275A	Cable Pulley	1	L series
5	81104A	Nut, .25-20 ESNA	11	L series
	81104A	Nut, .25-20 ESNA	9	S series
6	69872A	Pulley Bracket	1	L series
7	85700A	Screw, .25-20x1.00 Hex	1	S series
8	87026A	Washer, Flat .25	2	S series
9	608210	Spacer	1	S series
10	902731	Nylon Bearing	2	S series
11	40102A	Actuator	1	L series
12	920056	Nut, 6-32 ESNA	2	L series
	920056	Nut, 6-32 ESNA	4	S series
13	67476A	Shaft	1	S series
14	65629A	Squeegee Lever	1	S series
15	438360	Spring	1	S series
16	960510	Shoulder Screw	1	S series
17	61265A	Squeegee Lift Bracket	1	S series
18	68643A	Wear Plate	1	S series
19	980675	Washer	2	S series
20	962546	Screw, 10-24 x .50 Pn	2	S series
21	47374A	Switch	1	S series
22	962980	Screw, 6-32 x 1.00 Pn	2	L series
	962980	Screw, 6-32 x 1.00 Pn	4	S series
23*	962304	Screw, .312-18 x .50 Set	2	S series
24	65628A	Lever Weld.	1	S series
25	61682A	Upper Cable Assembly	1	S series
26	41208A	Battery Cable	Ref	All
27	41140A	Cable Assembly	1	All
28	41801A	Solenoid - Main / Brush	2	All
29	69878A	Plug Bracket	1	All
30	61681A	Upper Cable, Asm.	1	L series
31	58409A	Sleeve	1	L series
32	53424A	Cable Spring	1	L series
33	61680A	Cable Assembly Spring	1	L series
34	69372A	Lower Electrical Panel	1	All
35	46309A	Relay - Squeegee Up / Down	1	L series
36	40125A	Solenoid - Vac	1	All
37	980651	Washer	2	All
38	80043A	Shoulder Screw	2	All
39	41135C	Traverse, Control Board	1	All
40	962992	Screw, 8-32 x.74 Pn	4	All
41	32410B	Rear Cover	1	L series
	32418B	Rear Cover	1	S series
42	85391A	Screw, .25-20 x.62 Pn	2	All
43	87007A	Washer	6	All
44	980657	Washer, Lock	4	All
45	85806A	Screw, 1/4-20 x 3/4 Hex	1	All
46	85614A	Screw, 8-32 x 7/8 PN	2	L series
47	193951	Trim, 4 1/2" & 8"	1	All
48	87625A	Washer, Nylon 1 1/4 x 1/4 x 1/32	0-4	L series
49	87624A	Washer, Nylon 1 1/2 x 1/4 x 7/8	2	L series
50	98465A	Clamp, Metal 7/18	1	All
51	77079A	Label, w/Brake Warning	1	
	77080A	Label, w/o Brake Warning	1	
52	930093	Rivet	2	All
53	83307A	Stud, 1/4-20	8	All
54	42405A	Diode	1	All
55	54763A	Insert	6	L series
	54763A	Insert	4	S series
56	54764A	Insert	2	All
57◆	60233A	Hose Bracket	2	All
58	962957	Screw, 10-16 x 1/2	4	All
59	962798	Screw	1	L Series
60	920296	Nut	1	L Series
61	77354A	Label	1	L Series
	77355A	Label	1	S Series
62	77194B	Label, Traverse	1	All
63	77221A	Serial Tag	1	All
64	83010A	Rivet, Pop	1	All

NOTE: ◆ indicates a
change has been made
since the last publication
of this manual.

CLARKE TECHNOLOGY Encore S28/S33/S38 and L28/L33/L38
Brush Motor #45033A (S33, L28, S28)
Brush Motor #45036A (L38, L33, S38)

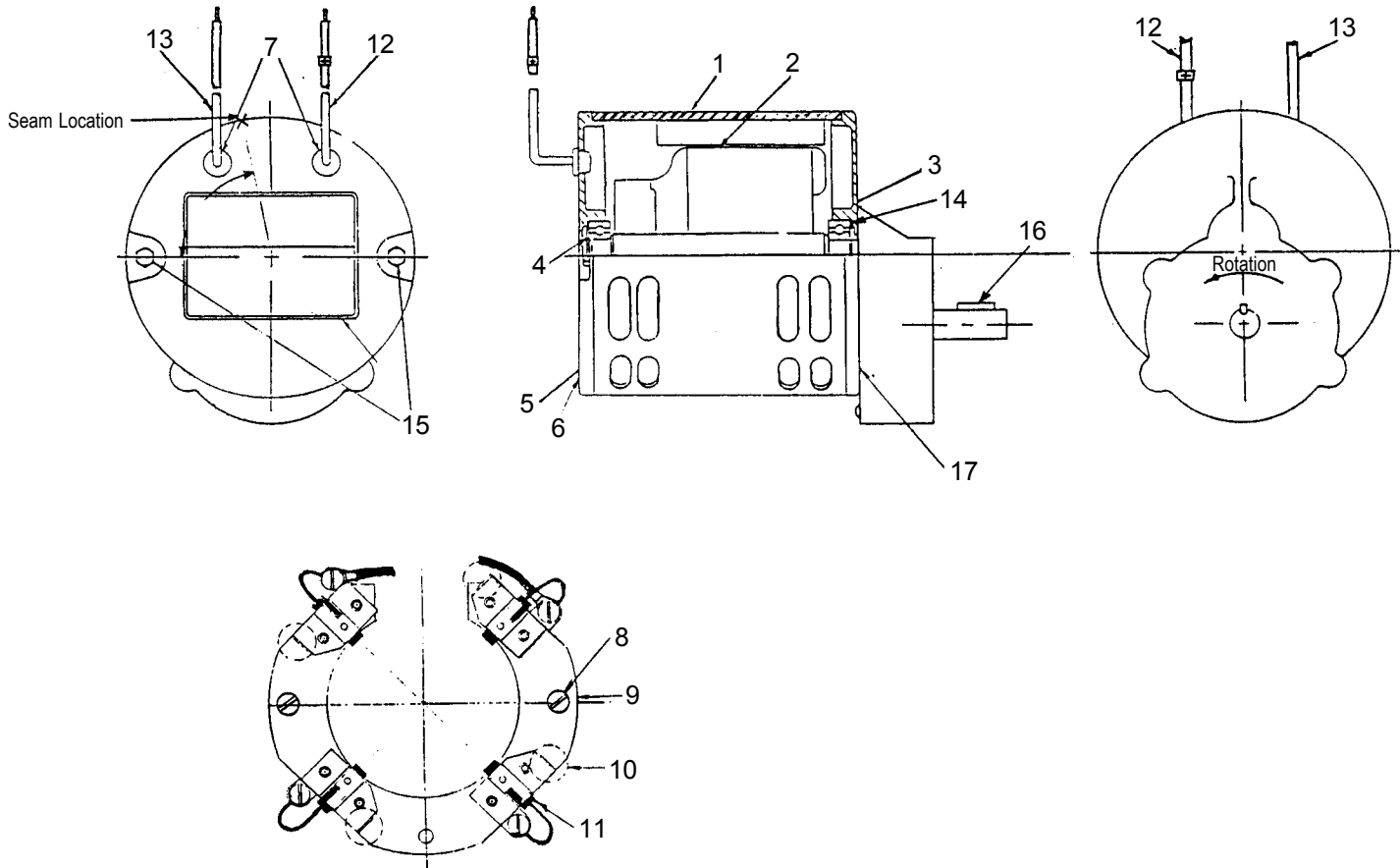

Ref #	Part No.	Description	Qty	45036A	45033A
1	56478A	Stator Assembly (w/Magnets & Clips)	1	x	
	46734A	Stator Assembly (w/Magnets & Clips)	1	x	
2	40312A	Armature Asm.(w/B.E. & F.E. bearings)	1	x	
	40318A	Armature Asm.(w/B.E. & F.E. bearings)	1	x	
3	902654	Bearings B.E.	1	x x	
4	902550	Bearing F.E.	1	x x	
5	51840A	Commutator Bracket Assembly (w/Brush BRD Assembly Leads)	1	x x	
6	50520A	Commutator Bracket	1	x x	
7	56480A	Strain Relief	2	x x	
8	962546	Brush Board Screw	2	x x	
9	50517A	Brush Board Asm. (w/springs & brushes)	1	x x	
10	448396	Brush Spring	4	x x	
11	40826A	Brush Assembly	4	x x	
12	55657A	Lead Assembly, Positive	1	x x	
13	55656A	Lead Assembly, Negative	1	x x	
14	59805A	Helical Washer	1	x x	
15	50515A	Thru Bolt	2	x x	
16	44809A	Shaft Key	1	x x	
17	54238A	B.E. Bracket Assembly (Gear Box)	1	x x	

**CLARKE TECHNOLOGY Encore S28/S33/S38 and L28/L33/L38
Gear Box #54238A 10/97**

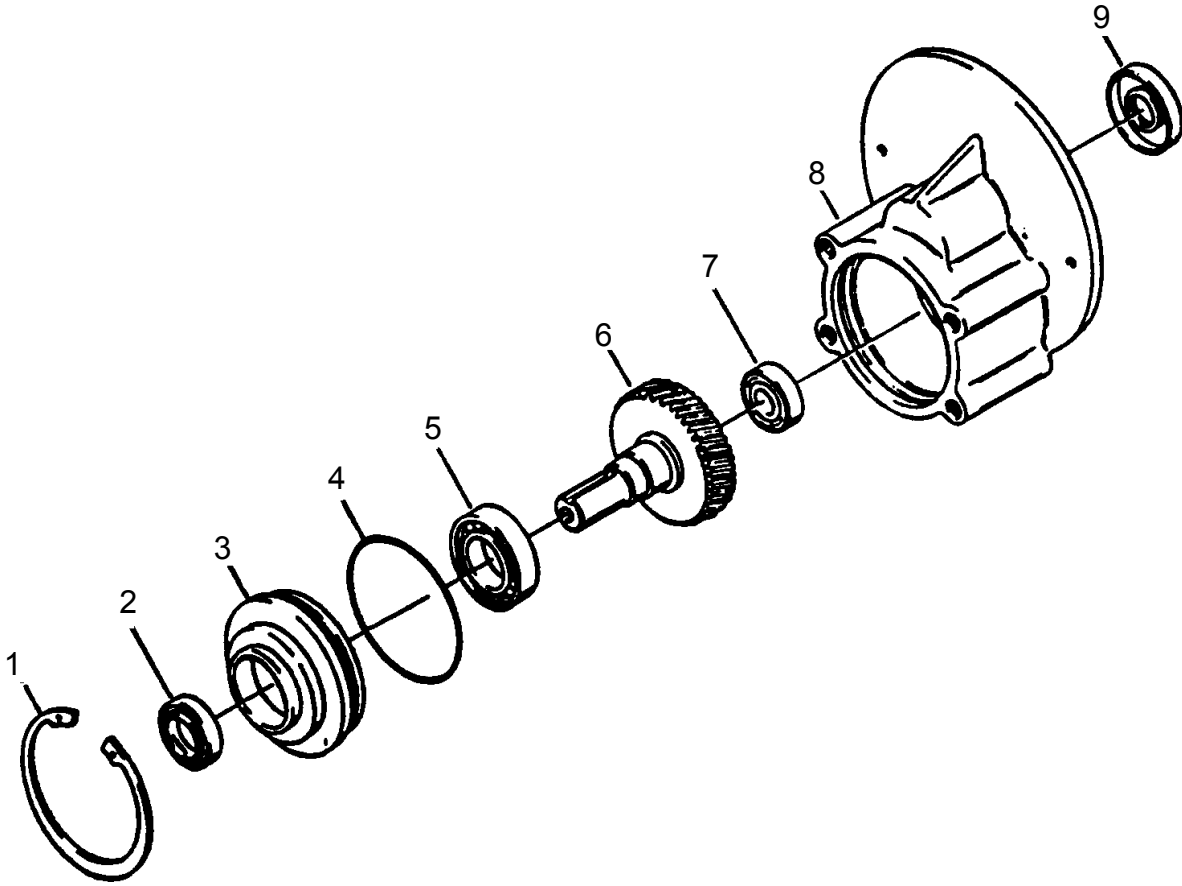

Ref #	Part No.	Description	Qty
1	57846A	Ring, Snap	1
2	507641	Seal, Oil, Small	1
3	52050A	Cap End	1
4	56668A	O'Ring	1
5	51176A	Bearing, Large	1
6	58316A	Shaft & Gear, Gearbox	1
7	902605	Bearing, Small	1
8	54883A	Housing	1
9	58144A	Seal, Oil Large	1
NI		Darina Grease	4oz.

**CLARKE TECHNOLOGY Encore S28/S33/S38 and L28/L33/L38
Vac Motor Assembly #45019A 10/97**

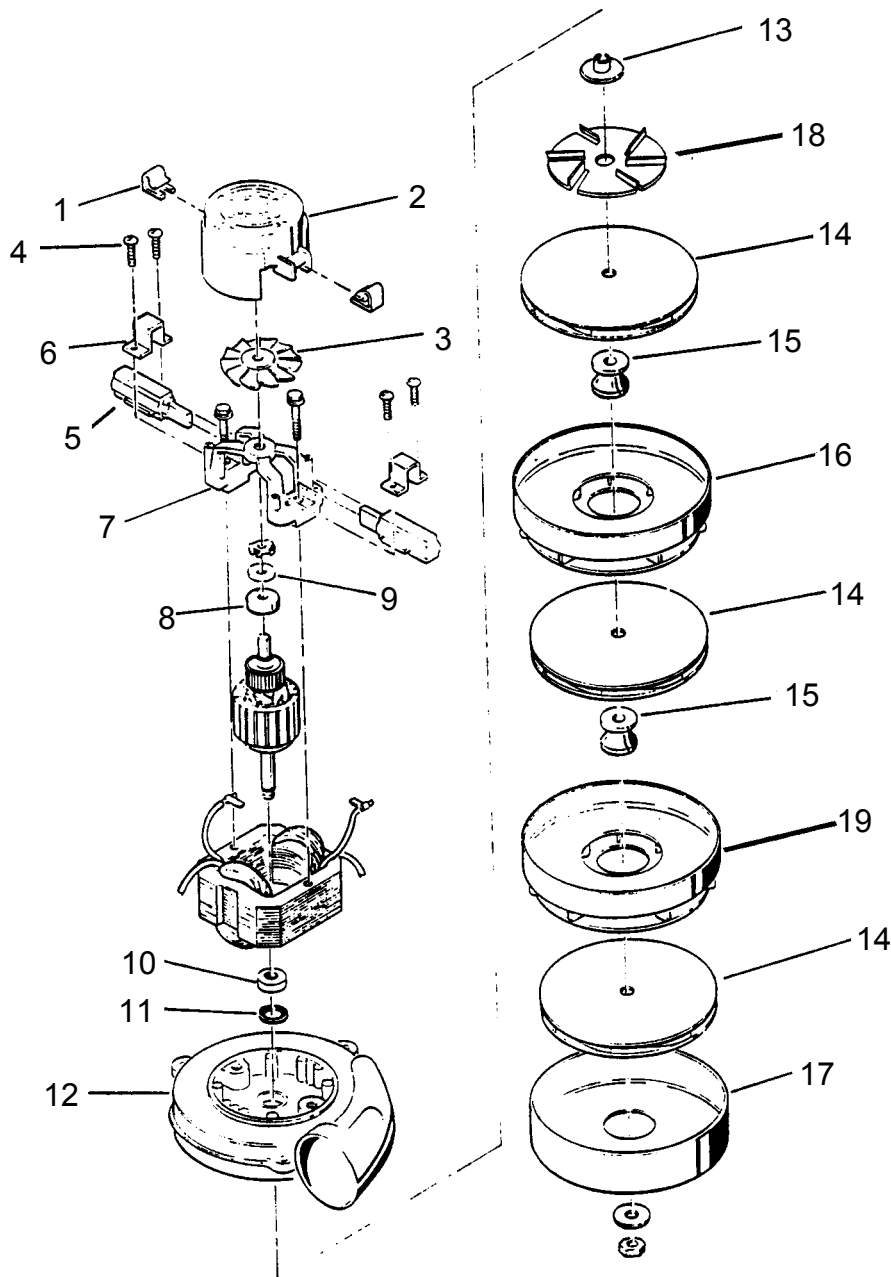

Ref #	Part No.	Description	Qty
1	51913A	Clip (optional)	2
2	54809A	Housing	1
3	53905A	Fan	1
4	85303A	Screw - 8-32 x 3/8	4
5	40830A	Carbon Brushes	2
6	51914A	Clamp	2
7	50618A	Bracket	1
8	53100A	Disc	1
9	902679	Bearing - Ball	1
10	902648	Bearing - ball, radial	1

Ref #	Part No.	Description	Qty
11	59803A	Washer - neoprene	1
12	50610A	Bracket and shell	1
13	58501A	Spacer	1
14	53914A	Fan - Rotating	3
15	658201	Spacer	2
16	53908A	Fan - Stationary	1
17	658506	Shell	1
18	53995A	Fan, Air Seal	1
19	53996A	Fan, Stationary	1

**CLARKE TECHNOLOGY Encore
Stature Transaxle Parts 8/00
PN 59111A, PN 59117A, and 59117B
Transaxle has Silver Motor**

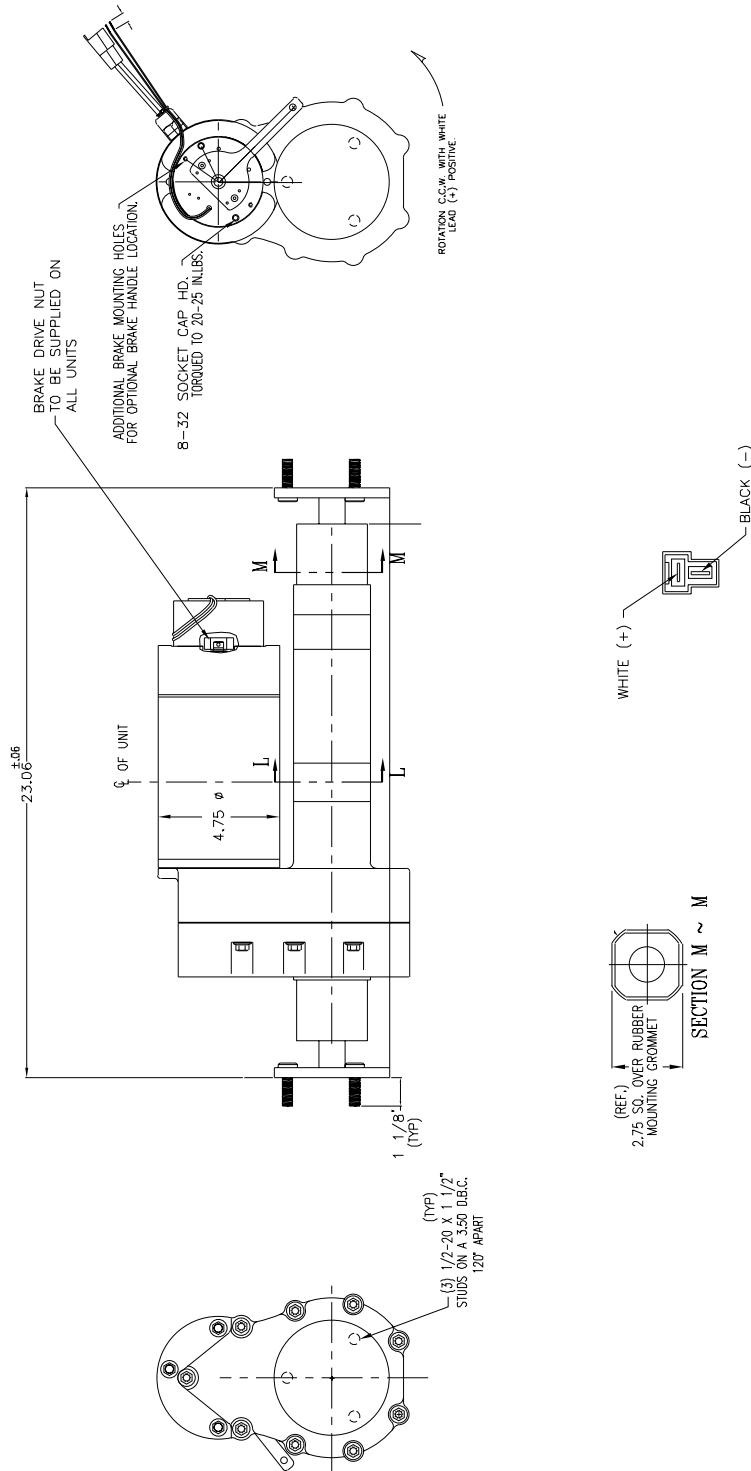

BRAKE ASSEMBLY PROCEDURE:

1. POP PLASTIC BRAKE NUT COVER OUT OF COMMUTATOR ENDBELL USING A SCREWDRIVER OR KNIFE.
2. LEAVING BRAKE ENGAGED, CAREFULLY LINE UP HEX BRAKE NUT WITH HEX IN CENTER OF BRAKE PAD, SLIDE BRAKE ASSEMBLY ON OVER NUT, AND ROTATE ENTIRE ASSEMBLY TO ACHIEVE REQUIRED BRAKE HANDLE LOCATION. CARE MUST BE TAKEN HERE TO NOT DAMAGE BRAKE PAD. PROPER LINE-UP IS ESSENTIAL.
3. APPLY LOCTITE BRAND THREADLOCKER #242 TO BOTH 8-32 X 2-1/8" LONG SOCKET CAP HEAD SCREWS (SUPPLIED) AND TORQUE TO 20-25 IN. LBS.
4. TY-RAP BRAKE COIL LEADS AND MOTOR LEADS TOGETHER ABOVE STRAIN RELIEF.

59111A - FAST START UNIT
59117A - SOFT START UNIT
59117B - SOFT START UNIT

Spare Parts List		
Description	Part No.	Qty
Transaxle Mount (Urethane)	40110A	2
Motor Brush Assembly	40111A	2
Motor Brush Spring	40112A	2
Male, Electrical Housing	912206	1
Male, Electrical Terminal Pin	912207	2
Cord & Terminal Assembly	40113A	1
Motor Asm. (Replacement)	45049A	1
Gearbox Asm. (Replacement)	63706A	1
Parking Brake Kit (electric)	10676A	1
Parking Brake Replacement	51200B	1

**CLARKE TECHNOLOGY Encore L33/L38
Imperial Transaxle Parts 8/00
PN 59116A
Transaxle has black motor
All models after SN#YH**

1 To replace coupler remove these two screws (Black) to separate the motor from gearbox to allow access to coupler

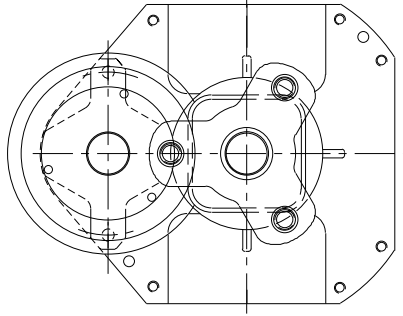

PERMANENT MAGNET MOTOR	
MFC. IN USA	
MODEL	4BC-2800
RPM	1200
VOLT.	36 VDC
AMP.	15
DUTY	CONT
DATE	
HP	.50
F	
INS.CL.	
MOUNT	FLANGE
SHAFT	TANG
AMB.	
SER. NO.	
18:1 RATIO	

SHAFT EXTENSION GUARD
BRAKE MTC. PROVISIONS
AVAILABLE WHEN REQUIRED

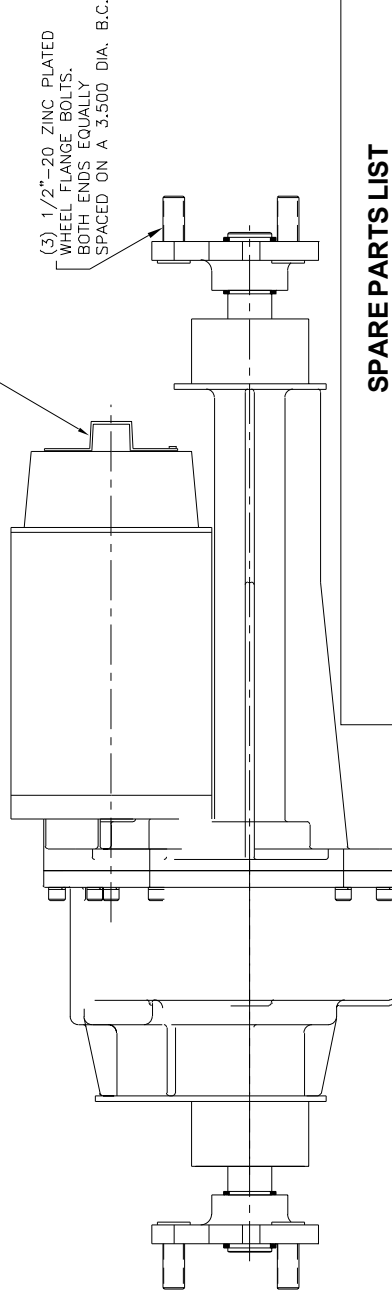

(3) 1/2" - 20 ZINC PLATED
WHEEL FLANGE BOLTS.
BOTH ENDS EQUALLY
SPACED ON A 3.500 DIA. B.C.

Parking Brake Spare Parts		
Part No.	Description	Qty
51097A	Pad, Friction	1
51098A	Hub, Shaft	1
80121A	Key, 4 MM - Hub	1
80122A	Set Screw, M3 - Hub	1

SPARE PARTS LIST		
59116A Imperial Transaxle (black motor)		
Part #	Description	Qty
36508A	Transaxle Ribber Mount	2
51720A	Brushes (Set of 4, including springs)	1
30074A	Cap, Brush	1
912206	Male Electrical Housing (connector)	1
912207	Male Electrical Pin (connector)	2
1 69195A	Coupler, Rubber	1
52663A	Steel Ring, Coupler	1
45048A	Motor, Replacement	1
54282A	Gearbox Replacement	1
10684A	Parking Brake Kit (electric)	1
51201C	Parking Brake Replacement	1

**CLARKE TECHNOLOGY Encore S28/S33/S38 and L28/L33/L38
36 Volt Battery Charger 10/97**

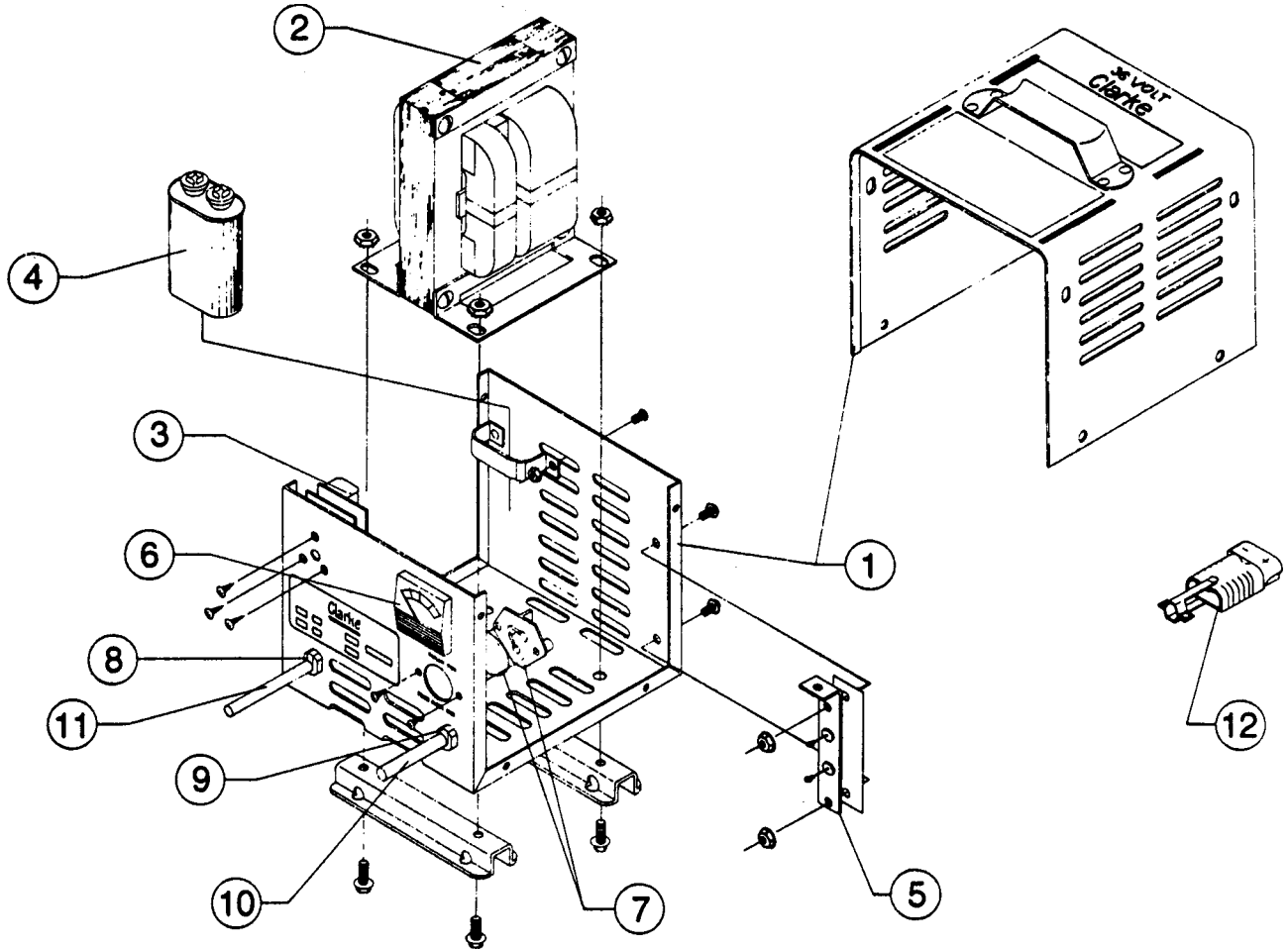

WARNING: All electrical repairs must be performed by qualified personnel only.

PARTS LIST FOR BATTERY CHARGERS

40506A - 36 Volt D.C., 25A, 115 Volt A.C., 60 Hz
 40505A - 36 Volt D.C., 25A, 230 Volt A.C., 50 Hz
 40507A - 36 Volt D.C., 25A, 230 Volt A.C., 60 Hz
 40514A - 36 Volt D.C., 36A, 115 Volt A.C., 60 Hz
 40515A - 36 Volt D.C., 36A, 230 Volt A.C., 50Hz

Ref #	Description	Charger Model Number				
		40506A Part #	40507A Part #	40505A Part #	40514A Part #	40515A Part #
1	Charger Case	42503A	42504A	51959A	41139A	51856A
2	Transformer	48400A	48412A	48401A	Ref	Ref
3	Electronic Timer Kit	41102A	41103A	41103A	41102A	41103A
4	Capacitor, 6 Mfd., 660 V.A.C.	912132	912132	912132	912132	912132
5	Heat Sink Assembly	912212	912212	912212	43301A	43301A
6	Ammeter	40200A	40200A	40200A	40210A	40210A
7	Fuse Assembly	912382	912382	912382	42704A	42704A
8	Strain Relief, A.C. Cord	837525	837525	837525	747553	747553
9	Strain Relief, D.C. Cord	747553	747553	747553	737502	737502
10	D.C. Cord Assembly	51973A	51973A	51973A	42303A	42303A
11	A.C. Cord Assembly	51974A	908947	908947	51974A	51857A
12	D.C. Plug	911185	911185	911185	911185	911185
	D.C. Plug Lock Key	795020	795020	795020	795020	795020

CLARKE TECHNOLOGY Encore S28/S33/S38 Electrical Schematic

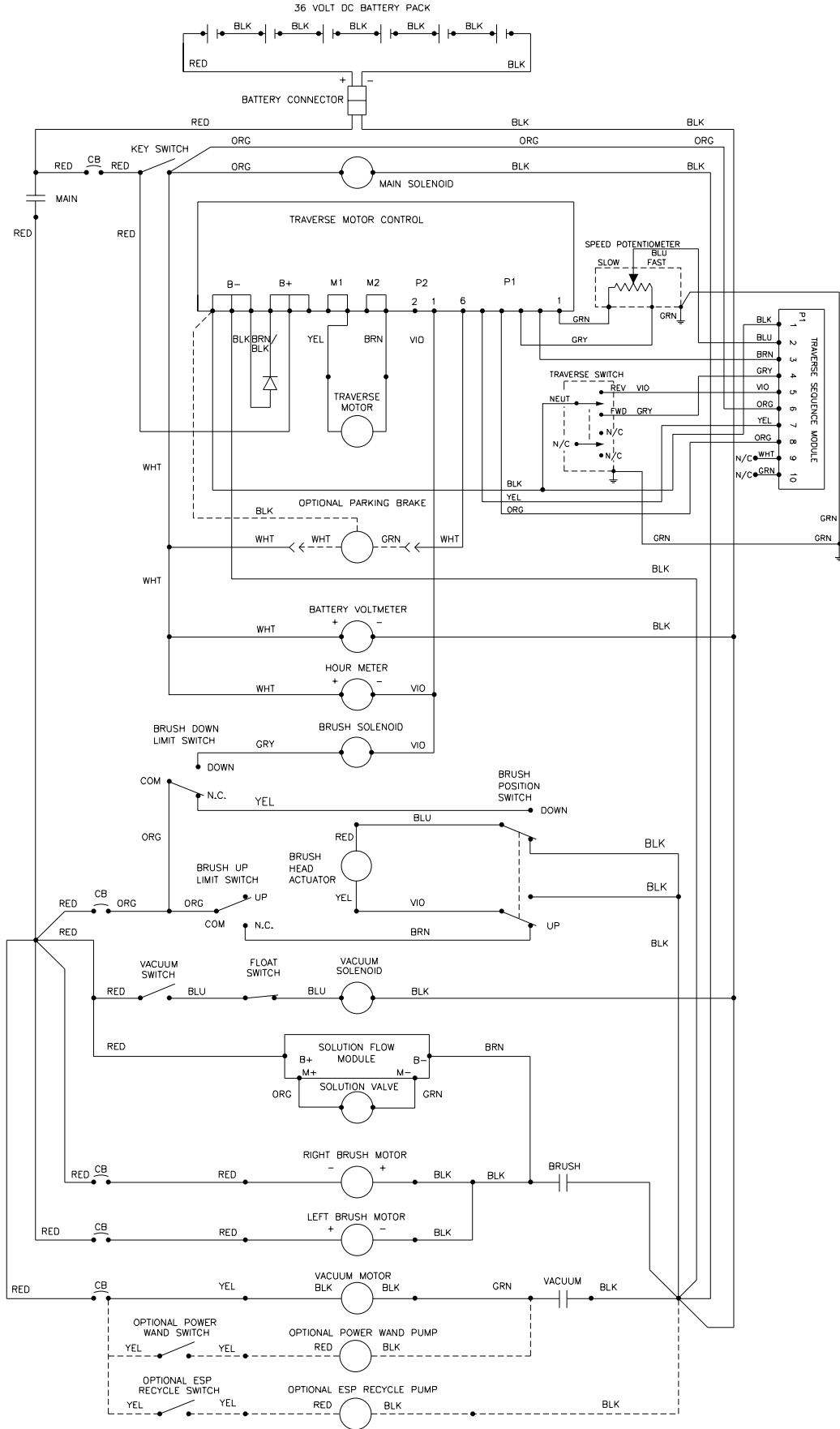

CLARKE TECHNOLOGY Encore L28/L33/L38 Electrical Schematic 4/99

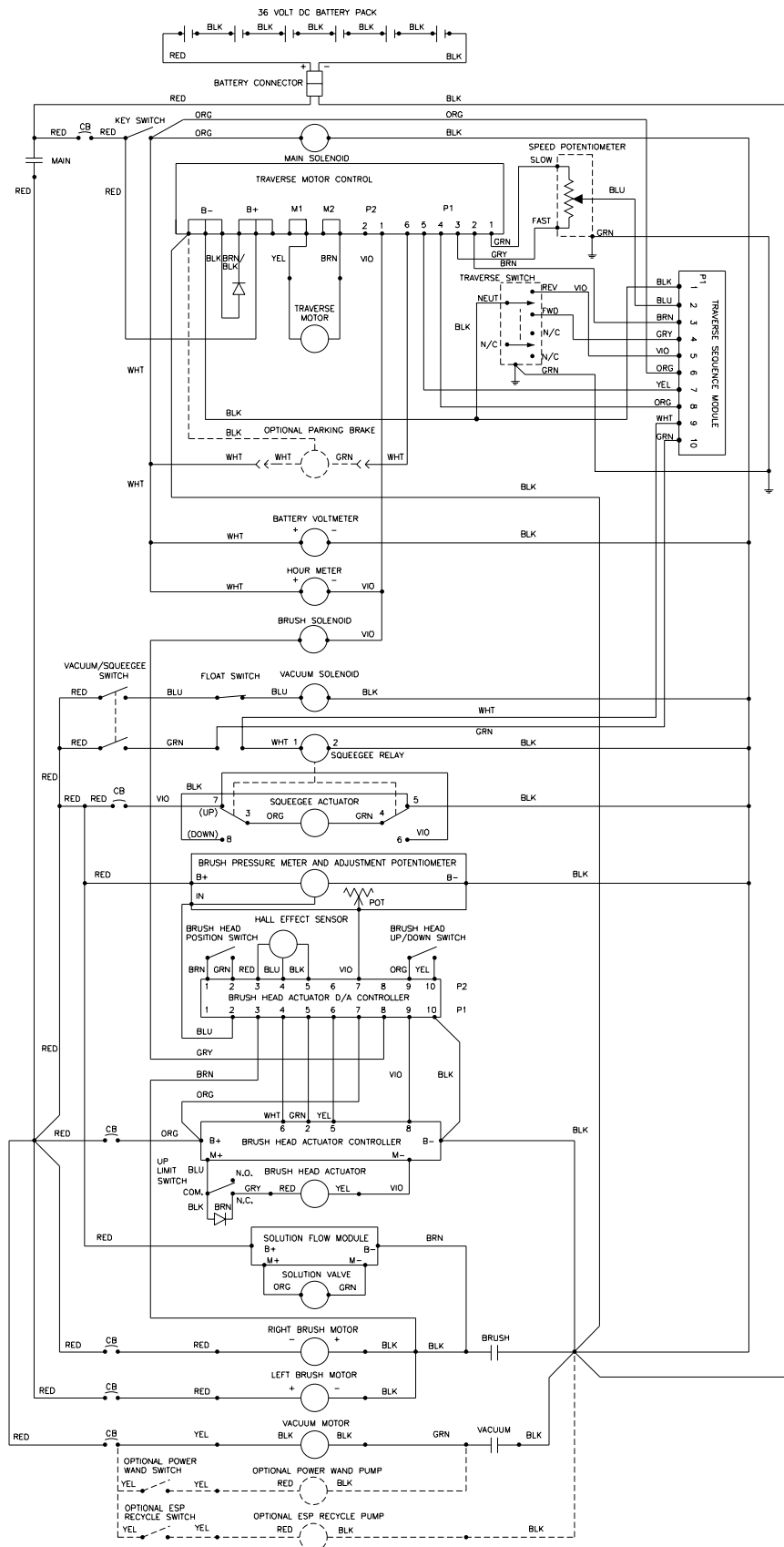

CLARKE TECHNOLOGY Encore L28/L33/L38 Connection Diagram 11/99

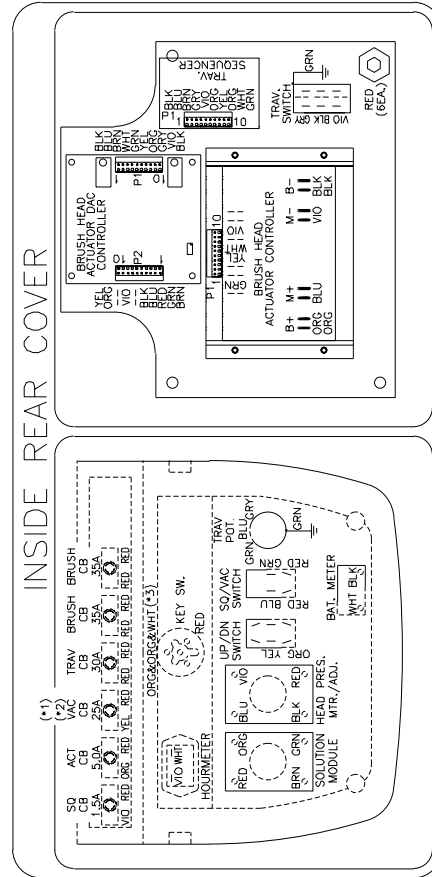
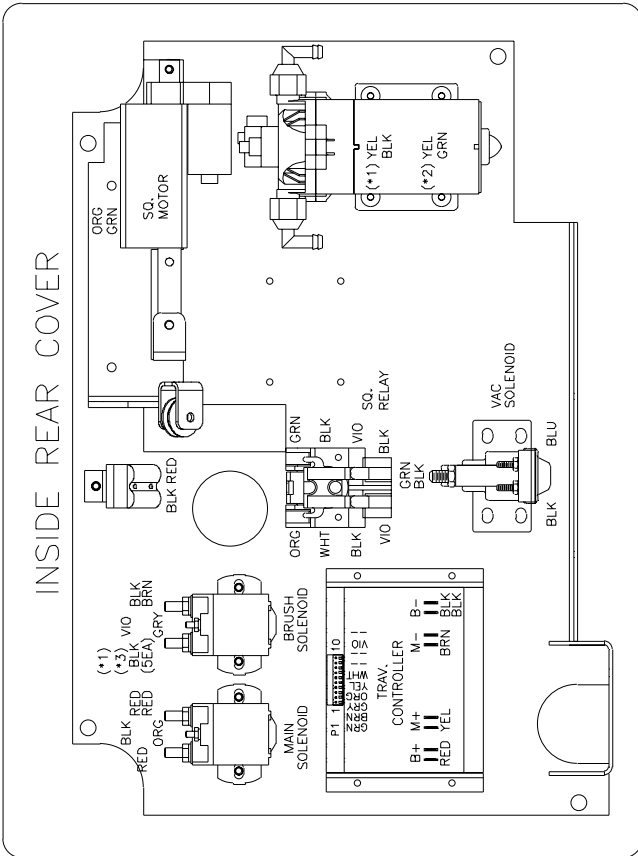
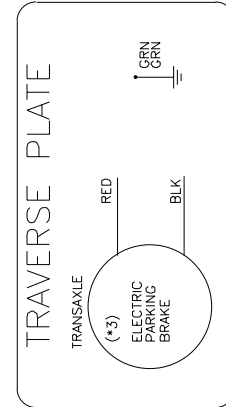
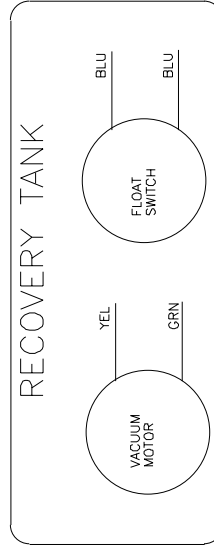
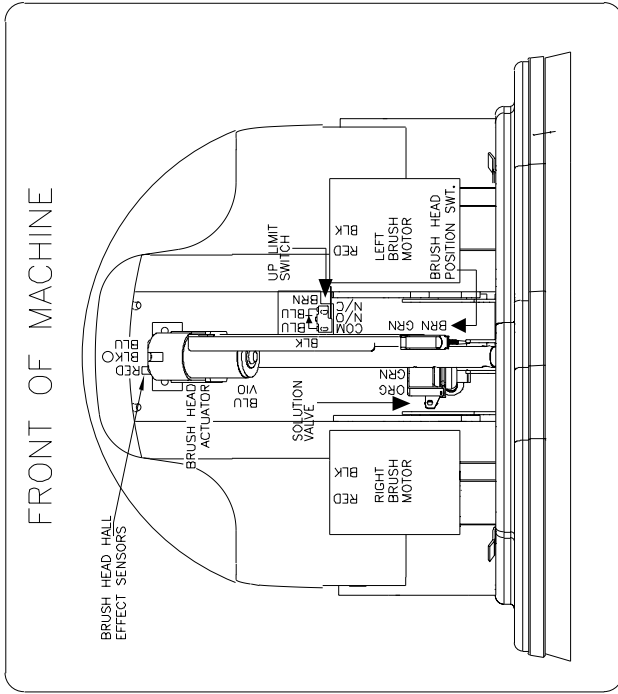

- (*)1 ESP RECOVERY SYSTEM OPTION.
- (*)2 POWERMIND SYSTEM OPTION.
- (*)3 ELECTRIC PARKING BRAKE OPTION.

ALTO® PRODUCT SUPPORT BRANCHES

U. S. A. Locations

HEAD OFFICE

ALTO U.S. Inc., St. Louis, Missouri
16253 Swingley Ridge Road, Suite 200
Chesterfield, Missouri 63017-1725

PRODUCTION FACILITIES

ALTO U.S. Inc., Springdale, Arkansas
2100 Highway 265
Springdale, Arkansas 72764
(501) 750-1000
Customer Service - 1-800-253-0367
Technical Service - 1-800-356-7274

ALTO U.S. Inc., Bowling Green, Ohio 43402
1100 Haskins

ALTO U.S. Inc., Clearwater, Florida 33765
1500 N. Belcher Road

SERVICE FACILITIES

ALTO U.S. Inc., Carlstadt, New Jersey 07072
150 Commerce Road
(201) 460-4774

ALTO U.S. Inc., Elk Grove, Illinois 60007
2280 Elmhurst Road
(847) 956-7900

ALTO U.S. Inc., Denver, Colorado 80204
1955 West 13th Ave.
(303) 623-4367

ALTO U.S. Inc., Houston, Texas 77040
7215 North Gessner Road

SALES AND SERVICE FACILITIES

ALTO U.S. Inc., Madison Heights, Michigan 48071-0158
29815 John R.
(810) 544-6300

ALTO U.S. Inc., Marietta, Georgia 30062
1355 West Oak Common Lane
(770) 973-5225

CLARKE TECHNOLOGY
AMERICAN SANDERS TECHNOLOGY
A.L. COOK TECHNOLOGY
Customer Service Headquarters and Factory
2100 Highway 265
Springdale, Arkansas 72764
(501) 750-1000

Technical Service
1-800-356-7274

European Locations

PRODUCTION FACILITIES

ALTO Danmark A/S, Aalborg
Blytaekkervej 2
DK-9000 Aalborg
+45 72 18 21 00

ALTO Danmark A/S, Hadsund
Industrikvarteret
DK-9560 Hadsund
+45 72 18 21 00

SALES SUBSIDIARIES

ALTO Canada Ltd., Rexdale Ontario
24 Constellation Ct.
(416) 675-5830

ALTO Overseas Inc., Sydney (Australia)
1B/8 Resolution Drive
Caringbah NSW 2229
+61 2 9524 6122

ALTO Cleaning Systems Asia Pte Ltd., Singapore
No. 17 Link Road
Singapore 619034
+65 268 1006

ALTO Deutschland GmbH, Frondenberg (Germany)
Ardeyer Str. 15
D-58730 Frondenberg
+49 2373 754 200

ALTO Cleaning Systems (UK) Ltd., Penrith
Gilwilly Industrial Estate
Penrith
Cumbria CA11 9BN
+44 1768 868 995

ALTO France S.A. Strasbourg
B.P. 44, 4 Place d'Ostwald
F-67036 Strasbourg
Cedex 2
+33 3 8828 8400

ALTO Nederland B.V. Vianen
Stuartweg 4C
NL-4131 NJ Vianen
+31 347 324000

ALTO Sverige AB, Molndal (Sweden)
Aminogatan 18
Box 4029
S-431 04 Molndal
+46 31 706 73 00

ALTO Norge A/S, Oslo (Norway)
Bjornerudveien 24
N-1266
+47 2275 1770

CLARKE TECHNOLOGY U.S. LIMITED WARRANTY

This Clarke Technology Industrial/Commercial Product is warranted to be free from defects in materials and workmanship under normal use and service for a period of one year from the date of purchase, when operated and maintained in accordance with Clarke Technology's Maintenance and Operations instructions.

The brush drive and traverse motors are warranted to be free from defects in materials and workmanship under normal use and service for one additional year, for a total of two years, from the date of purchase, provided the motors are inspected for carbon motor brush wear at six-month intervals by an authorized Clarke Technology repair station. Failure to comply with the six-month inspection requirement or failure to replace worn motor brushes identified during the inspection will void the additional one-year warranty on the motors. Cost of the six-month inspection and replacement of carbon motor brushes is the responsibility of the purchaser. In the event of a warranty claim on the motors, proof of inspection and any required motor brush replacement must be provided.

This warranty is extended only to the original purchaser for use of the product. It does not cover normal wear parts such as electrical cable, rubber parts, hoses and motor brushes.

Clarke Technology's liability under this warranty is limited to repair of the product and/or replacement of parts and is given to purchaser in lieu of all other remedies, including INCIDENTAL AND CONSEQUENTIAL DAMAGES.

THERE ARE NO EXPRESS WARRANTIES OTHER THAN THOSE SPECIFIED HEREIN. THERE ARE NO WARRANTIES WHICH EXTEND BEYOND THE DESCRIPTION OF THE FACE HEREOF. NO WARRANTIES, INCLUDING BUT NOT LIMITED TO WARRANTY OF MERCHANTABILITY, SHALL BE IMPLIED. A warranty registration card is provided with your Clarke Technology product. Return the card to assist Clarke Technology in providing the performance you expect from your new floor machine.

If a difficulty develops with the product, you should: a) Contact the nearest authorized Clarke Technology repair location or contact the Clarke Technology Service Operations Department, 2100 Highway 265, Springdale, Arkansas 72764, for the nearest authorized Clarke Technology repair location. Only these locations are authorized to make repairs to the product under this warranty. (b) Return the product to the nearest Clarke Technology repair location. Transportation charges to and from the repair location must be prepaid by the purchaser. Clarke Technology will repair the product and/or replace any defective parts with out charge within a reasonable time after receipt of the product.

ALTO U.S. Inc., 2100 Highway 265, Springdale, Arkansas 72764.

BATTERY U.S. WARRANTY

In addition to the items above (except as to the one-year period), any original equipment Clarke Technology Battery which becomes unserviceable under normal use within a period of ninety (90) days from date of sale to the original user will be repaired or replaced with one of equal specification at our option, F.O.B. any authorized Clarke Technology Sales or Service Branch, with no charge to the user, except transportation costs. After expiration of the above ninety (90) day period, any battery which fails under normal use will be adjusted to the original user with a new battery of equal specification on an eighteen (18) months pro rate basis from the date of purchase. Adjustment will be determined using the then current list price, plus transportation costs.

Warranty is rendered null and void if battery is not kept filled to the proper level with DISTILLED WATER.

CLARKE TECHNOLOGY: POLYDUR® AUTOMATIC SCRUBBER SOLUTION AND RECOVERY TANK U.S. EIGHT-YEAR GUARANTEE

Your new Clarke Technology Encore Automatic Scrubber has polydur Solution and Recovery Tanks. Polydur is a rotationally molded, low-density linear polyethylene that won't crack or dent, and withstands most corrosives and temperature extremes. Clarke Technology backs up your Polydur tanks with an eight-year guarantee. If a tank breaks or leaks under normal use within eight years of the date of purchase, it will be replaced free.

CLARKE TECHNOLOGY UNIBODY FRAME U.S. FIVE-YEAR WARRANTY

Clarke Technology warranties the frame for the new Encore automatic Scrubbers for a period of five years against defects in materials and workmanship under normal use and service.

**CLARKE TECHNOLOGY reserves the right to make changes or improvements to its machine without notice.
Always use genuine Clarke Technology Parts for repair.**



**CLARKE TECHNOLOGY
2100 Highway 265
Springdale, Arkansas, 72764**