

1 1/2" x 13" Evolution Wand

Item	Ref. No.	Qty	Description	Item	Ref. No.	Qty	Description
#1	000-163-034	1	WAND 1 1/2 X 13 Head Evo Alum - Note1 and 2	#20	000-174-200	2	WASHER 0.260 ID X 1.0 OD FLAT 0.074 THK SS
#2	000-152-012	1	SLEEVE 1-1/2DIA X 6 LG - BLACK	#21	000-174-201	4	WASHER 1/4" RUBBER
#3	000-143-731	2	SCREW 8-32 X 1 1/8 LNG SS	#22	000-090-096	1	MANIFOLD SPRAY 1/4 NPT X 6.23 LNG
#4	000-094-059	2	NUT 8-32 NYLOCK SS	#23	000-076-121	2	11001 V-JET BRASS - 150PSI
#5	000-015-1307	1	BRACKET HOSE W/D-RING	#23	000-076-122	2	11002 V-JET BRASS - 300PSI
#6	000-143-733	1	SCREW 10-32 X 1/4 HHCS SS	#23	000-076-123	2	11003 V-JET BRASS - 500PSI
#7	000-108-210	1	GLIDE DELRIN 13" HEAD	#24	000-081-862	1	LABEL EVOLUTION 7.5 x 2.4
#8	000-143-729	1	SCREW 10-24 X 3/8 SET SS	#25	000-061-194	1	HANDLE 1.5" STEEL W/VINYL
#9	000-068-1081	1	HOSE 1/8 BLACK ASSEMBLY	#26	000-027-121	1	CAP BLACK VINYL 1-1/2 ID X 1LG
#10	000-169-244	1	VALVE CONTROL BRASS	#27	000-027-122	1	CAP BLACK VINYL 0.5" ID
#11	000-052-071	1	NIPPLE 1/4" NPT HEX				
#12	000-052-050	1	QUICK CONNECT 1/4" MALE BRASS	Also Available - not shown			
#13	000-052-433	1	QUICK CONNECT 1/8" MALE BRASS	#7 / #8	000-108-211	1	GLIDE SLOTTED 13 EVO W/ SET SCW
#14	000-052-434	1	QUICK CONNECT 1/8" FEMALE BRASS	#0	000-168-020	1	TUBE W/ HEAD - EVO 13
#15	000-015-1308	2	BRACKET SPRAY MANIFOLD				
#16	000-143-730	2	SCREW 10-32 X 3/8 HHCS SS				
#17	000-174-001	2	WASHER #10 FLAT SS				
#18	000-108-209	2	STRAP HOSE 1.5 X 8.5 VELCRO				
#19	000-094-071	2	NUT 1/4-20 NYLOCK SS				

NOTES:

Note 1: This tool is suitable only for use with water or chemical with a pH between 5 and 10
Note 2: This tool is supplied with jets installed for operation at 300 PSI (2 x 11002).

IMPORTANT!

Choosing a Spray Tip

This wand shipped with Spray Tip part number 11002 installed (optimized for use with machines that operate at 200-400 PSI). See the Table below to determine the suggested spray tip for using this wand with machines that operate at different pressures.

Spray Tip Suggested Use			
Status	#	# on tip (see photo at right)	Recommended for use with machines that operate at these pressures
Wand ships with these tips loose	1	11001	100 – 200 PSI
Wand ships with these tips installed	2	11002	200 – 400 PSI
Wand ships with these tips loose	3	11003	400 – 500 PSI

FIGURE 1

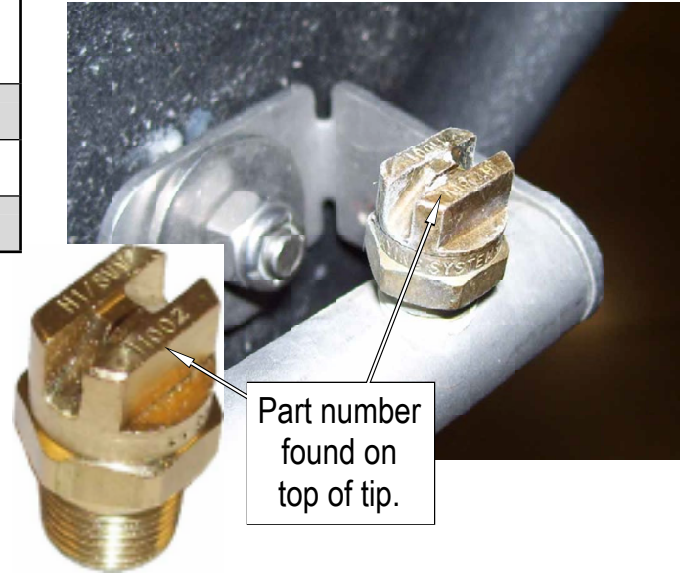

Installing Spray Tips

- 1 Use a wrench to remove the two spray tips from the wand manifold.
- 2 Use the table above to determine which spray tips to install.
- 3 Teflon tape may be used to prevent water leakage around the threads of the spray tips.
- 4 Thread the tips into the manifold. When tightened, the tip's slot must be parallel to the wand tool (as shown below).

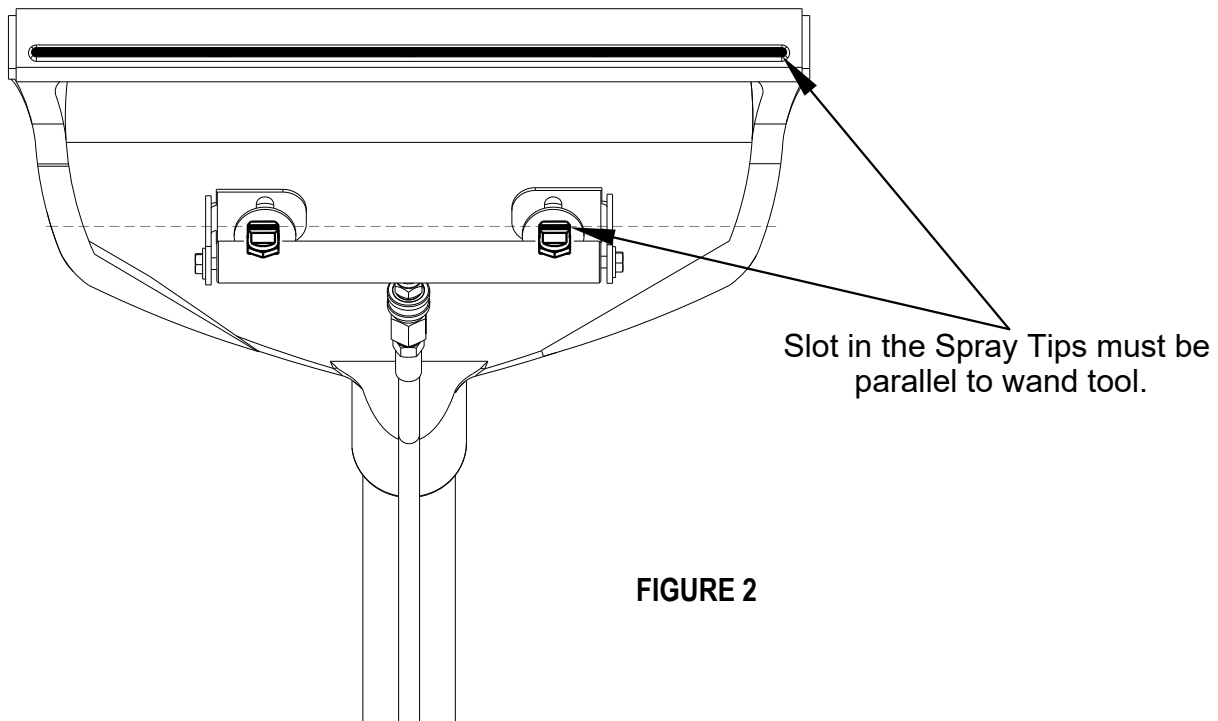

FIGURE 2