



Model Part No.:
608352 - 120V
609260 - 120V CSA

FALCON™ 2800 PLUS

AUTOMATIC CARPET EXTRACTOR

OPERATOR AND PARTS MANUAL

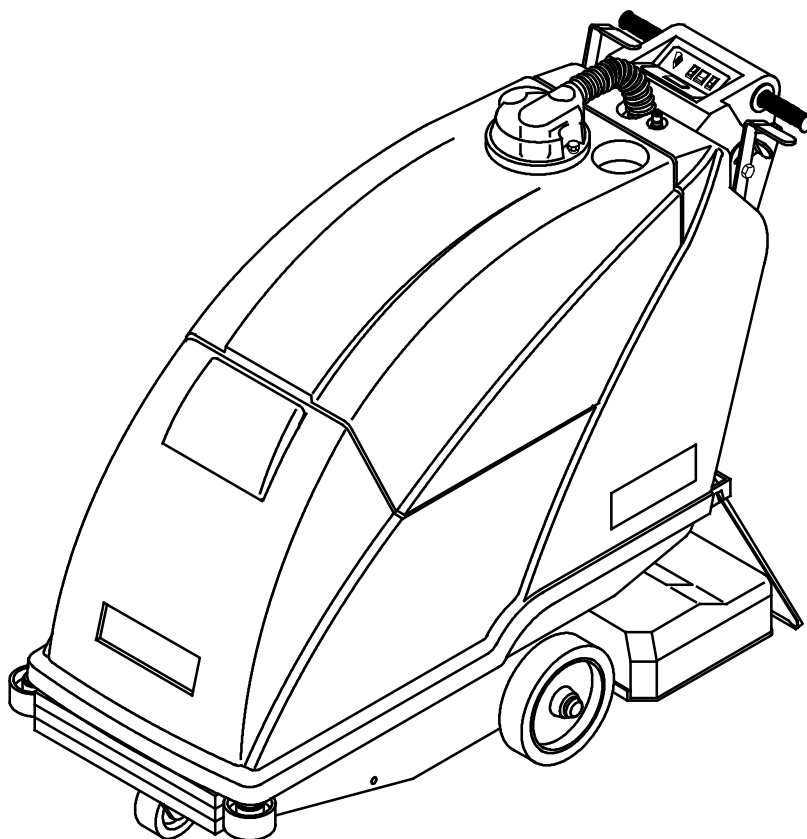

To view, print or download
the latest manual, visit:

www.nobles.com/manuals

www.nobles.com

607210
Rev. 04 (05-2013)



OPERATION

This manual is furnished with each new model. It provides necessary operation and maintenance instructions and an illustrated parts list.

Read this manual completely and understand the machine before operating or servicing it.

When ordering replacement parts, use the illustrated parts lists section in this manual. Before ordering parts or supplies, be sure to have your machine model number and serial number available. Parts and supplies may be ordered by phone or mail from any authorized parts and service center, distributor or from any of the manufacturer's subsidiaries.

This machine will provide excellent service. However, the best results will be obtained at minimum costs if:

- The machine is operated with reasonable care.
- The machine is maintained regularly - per the machine maintenance instructions provided.
- The machine is maintained with manufacturer supplied or equivalent parts.

MACHINE DATA

Please fill out at time of installation for future reference.

Model No.- _____

Install. Date - _____

Serial No.- _____



PROTECT THE ENVIRONMENT

Please dispose of packaging materials, old machine components such as batteries, hazardous fluids, including antifreeze and oil, in a safe environmentally way according to your local waste disposal regulations.



Always remember to recycle.

Tennant Company

PO Box 1452

Minneapolis, MN 55440

Phone: (800) 553- 8033 or (763) 513- 2850

www.nobles.com

Nobles is a registered United States trademark of Tennant Company.

Specifications and parts are subject to change without notice.

Copyright ©2000, 2003, 2007, 2012, 2013 Tennant Company.

All rights reserved. Printed in U.S.A.

TABLE OF CONTENTS

SAFETY PRECAUTIONS	4	ELECTRICAL DIAGRAMS	18
GROUNDING INSTRUCTIONS	5	PARTS LIST	20
SAFETY LABEL	6	RECOVERY TANK GROUP	20
MACHINE COMPONENTS	7	SOLUTION TANK GROUP	22
CONTROL PANEL SYMBOLS	7	DRIVE WHEEL GROUP	24
SETUP AND OPERATION	8	REAR PANEL GROUP	26
MACHINE INSTALLATION	8	CONTROL CONSOLE GROUP	28
MANEUVERING MACHINE WITHOUT		PICK-UP HEAD GROUP	30
USE OF POWER	8	BRUSH BASE GROUP	32
FILLING SOLUTION TANK	8	PLUMBING GROUP	34
ADJUSTING CONTROL GRIP HEIGHT	8	PUMP BREAKDOWN	36
CONNECTING MACHINE TO		OPTIONS	37
POWER SOURCE	9	SOLUTION AND VACUUM HOSES	37
PRE- OPERATION CHECKS	9	FLOOR TOOL, LOW PRESSURE	
CLEANING CARPET	9	330mm (13 in)	38
OPERATING PRE- SPRAY WAND	11	FLOOR TOOL, LOW PRESSURE	
ADJUSTING BRUSH HEIGHT	11	406mm (16 in)	40
CIRCUIT BREAKERS	11	HAND TOOL, 127 mm (5 in)	42
ACCESSORY TOOL SETUP AND		HAND TOOL, CREVICE	
OPERATION (OPTION)	11	76 mm (3 in)	42
DRAINING TANKS	12	HAND TOOL, UPHOLSTERY	
MACHINE MAINTENANCE	12	LOW PRESSURE	43
DAILY MAINTENANCE	13		
WEEKLY MAINTENANCE	13		
MONTHLY MAINTENANCE	14		
QUARTERLY MAINTENANCE	14		
ADJUSTING DRIVE BELT	14		
TRANSPORTING MACHINE	15		
STORING MACHINE	15		
RECOMMENDED STOCK ITEMS	15		
TROUBLE SHOOTING	15		
SPECIFICATIONS	17		

OPERATION

SAFETY PRECAUTIONS

This machine is intended for commercial use. It is designed exclusively to clean carpets in an indoor environment and is not constructed for any other use. Use only recommended accessory tools and commercially available carpet cleaners intended for machine application.

All operators must read, understand and practice the following safety precautions.

The following warning alert symbol and the "FOR SAFETY" heading are used throughout this manual as indicated in their description:

 **WARNING:** To warn of hazards or unsafe practices which could result in severe personal injury or death.

FOR SAFETY: To identify actions which must be followed for safe operation of equipment.

Failure to follow these warnings may result in: personal injury, electrocution, electrical shock, fire or explosion.

 **WARNING:** Do Not Use Flammable Liquids Or Operate Machine In Or Near Flammable Liquids, Vapors Or Combustible Dusts.

This machine is not equipped with explosion proof motors. The electric motors will spark upon start up and during operation which could cause a flash fire or explosion if machine is used in an area where flammable vapors/liquids or combustible dusts are present.

 **WARNING:** Do Not Pick Up Flammable Materials Or Reactive Metals.

 **WARNING:** Do Not Operate With Damaged Power Cord. Do Not Modify Plug. Unplug power Cord Before Servicing Machine.

If the supply cord is damaged or broken, it must be replaced by the manufacturer or it's service agent or a similarly qualified person in order to avoid a hazard.

 **WARNING:** Do Not Use Outdoors. Do Not Expose To Rain. Store Indoors.

The following information signals potentially dangerous conditions to the operator or equipment:

FOR SAFETY:

1. Do not operate machine:
 - With flammable liquids or near flammable vapors as an explosion or flash fire may occur.
 - Unless trained and authorized.
 - Unless operator manual is read and understood.
 - Unless cord is properly grounded.
 - With damaged cord or plug.
 - If not in proper operating condition.
 - In outdoor areas.
 - In standing water.
 - With the use of additional extension cords. Only use manufacturer's extension cord equipped with machine which has proper capacity and is grounded.
2. Before operating machine:
 - Make sure all safety devices are in place and operate properly.
3. When using machine:
 - Do not run machine over cord.
 - Do not pull machine by plug or cord.
 - Do not pull cord around sharp edges or corners.
 - Do not unplug by pulling on cord.
 - Do not stretch cord.
 - Do not handle plug with wet hands.
 - Keep cord away from heated surfaces.
 - Go slow on inclines and slippery surfaces.
 - Use care when reversing machine.
 - Report machine damage or faulty operation immediately.
 - Never allow children to play on or around.
 - Follow mixing and handling instructions on chemical containers.
4. Before leaving or servicing machine:
 - Stop on level surface.
 - Turn off machine.
 - Unplug cord from wall outlet.

5. When servicing machine:

- Unplug cord from wall outlet.
- Avoid moving parts. Do not wear loose jackets, shirts, or sleeves.
- Block machine tires before jacking up.
- Use hoist or jack that will support the weight of the machine.
- Use manufacturer supplied or approved replacement parts.
- All repairs must be performed by a qualified service person.
- Do not modify the machine from it's original design.

6. When transporting machine:

- Turn machine off.
- Get assistance when lifting machine.
- Unplug cord from wall outlet.
- Use a recommended ramp when loading/unloading into/off truck or trailer.
- Use tie-down straps to secure machine to truck or trailer.

GROUNDING INSTRUCTIONS

Machine must be grounded. If it should malfunction or breakdown, grounding provides a path of least resistance for electrical current to reduce the risk of electrical shock. This machine is equipped with a cord having an equipment-grounding conductor and grounding plug. The plug must be plugged into an appropriate outlet that is properly installed in accordance with all local codes and ordinances. Do not remove ground pin; if missing, replace plug before use.

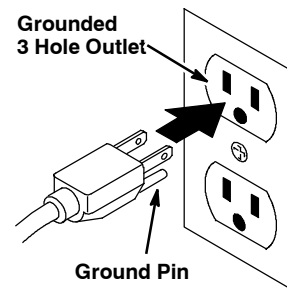

OPERATION

SAFETY LABEL

The safety label appears on the machine in the location indicated. Replace the label if it is missing or becomes damaged or illegible.

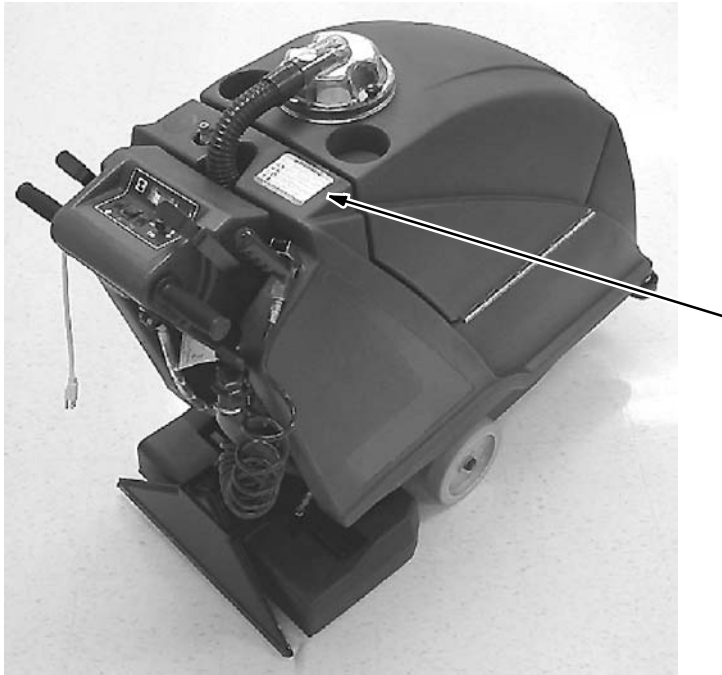

WARNING LABEL - LOCATED ON TOP OF THE SOLUTION TANK.

⚠ WARNING	
  	
EXPLOSION, FIRE AND SHOCK HAZARD. AVOID INJURY. <ul style="list-style-type: none">• Do Not Use or Pick Up Flammable Materials.• Do Not Use Near Flammable Liquids, Vapors or Combustible Dusts.• Do Not Operate With Damaged Power Cord. Do Not Modify Plug. Unplug Power Cord Before Servicing Machine.• Do Not Use Outdoors. Do Not Expose to Rain. Store Indoors.	
⚠ AVERTISSEMENT	
RISQUE D'EXPLOSION, D'INCENDIE ET DE DÉCHARGE. ÉVITEZ LES BLESSURES. <ul style="list-style-type: none">• N'utilisez Pas ou Ne Ramassez Pas de Matériaux Inflammables.• N'utilisez Pas Près de Liquides, Vapeurs ou Poussières Inflammables.• N'utilisez Pas la Machine Avec un Cordon d'Alimentation Endommagé. Ne Modifiez Pas la Prise. Débranchez le Cordon d'Alimentation Avant d'Entretenir la Machine.• N'utilisez Pas en Extérieur. N'Exposez Pas à la Pluie. Entrezposez à l'Intérieur.	
⚠ ADVERTENCIA	
PELIGRO DE EXPLOSIÓN, FUEGO, DESCARGA EVITE LESIONES. <ul style="list-style-type: none">• No Use Ó Recoja Materiales Flamables.• No Use Cerca De Líquidos Flamables, Vapores Ó Materiales Combustibles.• No Use Con Cable De Corriente Dañado. No Altere El Enchufe. Desconecte Cable De Corriente Antes Del Mantenimiento.• No Use Al Aire Libre. No Exponga A La Lluvia. Guarde Bajo Techo.	

MACHINE COMPONENTS

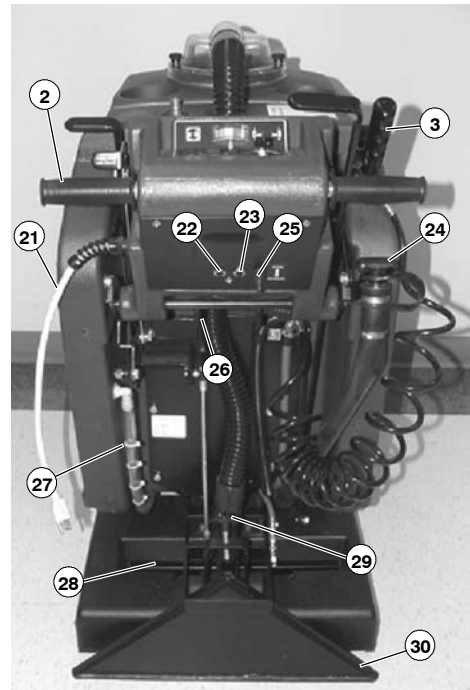
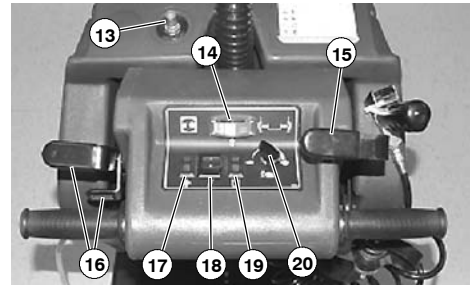
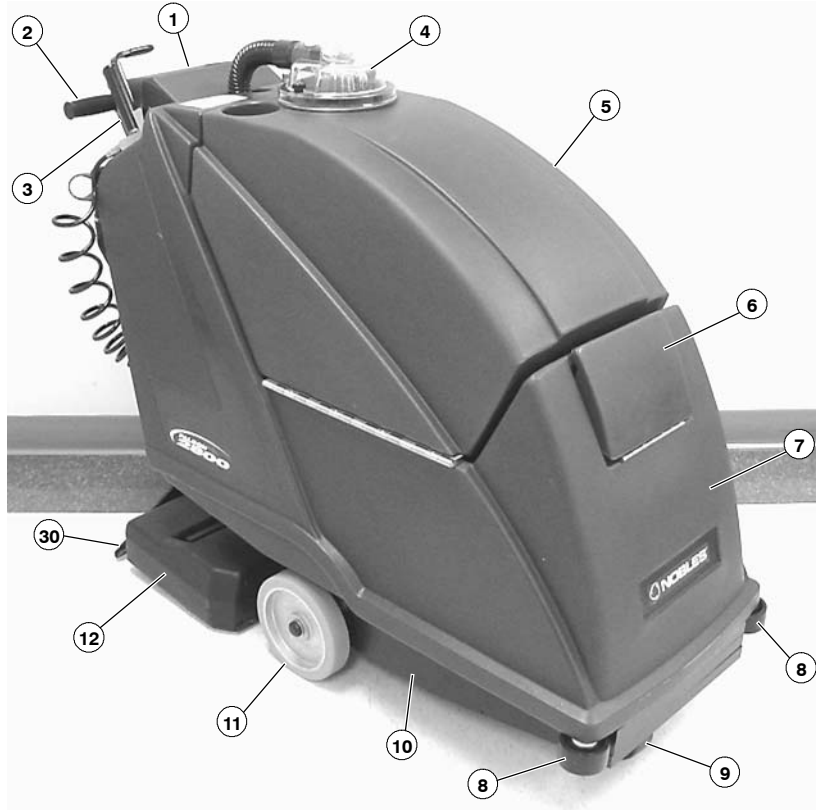

- | | | |
|-------------------------------------|-------------------------------------|---------------------------------------|
| 1. Control Console | 11. Non-Marking Drive Wheels | 21. Power Cord Pigtail |
| 2. Control Grips | 12. Brush Base | 22. Brush Motor Circuit Breaker |
| 3. Prespray Wand | 13. Accessory Solution Hose Coupler | 23. Drive Motor Circuit Breaker |
| 4. Recovery Tank Dome | 14. Brush Pressure Meter | 24. Recovery Tank Drain Hose |
| 5. Recovery Tank | 15. Reverse Release Lever | 25. Cleaning Mode Switch |
| 6. Solution Tank Fill Door | 16. Brush Lever Raise/Lower | 26. Adjustable Control Console Levers |
| 7. Solution Tank | 17. Vacuum ON/OFF Switch | 27. Solution Tank Level Indicator |
| 8. Wall Rollers | 18. Main ON/OFF Switch | 28. Spray Bar |
| 9. Front Caster | 19. Pump ON/OFF Switch | 29. Brush Height Adjustment Knob |
| 10. Inline Solution Filter Strainer | 20. Speed Control Knob | 30. Vacuum Pick-Up Head |

CONTROL PANEL SYMBOLS



OPERATION

SETUP AND OPERATION

MACHINE INSTALLATION

ATTENTION: To prevent damage to machine when uncrating, do not attempt to drive or roll off skid. Carefully lift machine with assistance or use a ramp.

Your new machine requires very little setup.

1. Place recovery tank dome on top of solution tank and secure with two thumbscrews (Figure 1).
2. Insert black vacuum hose into dome opening.
3. Install pre-spray wand into opening on right side of tank, next to control housing (Figure 1).

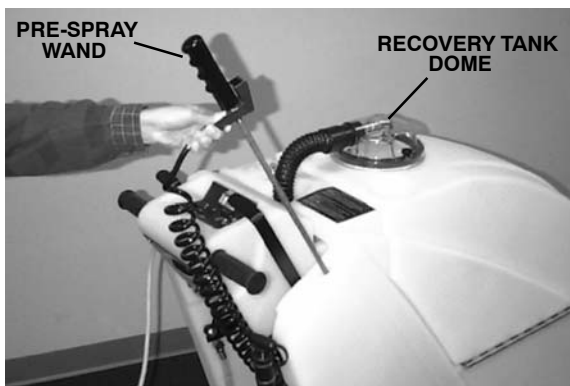

FIG. 1

MANEUVERING MACHINE WITHOUT USE OF POWER

Your machine will glide easily across floor by pushing machine forward (without power). To pull machine backwards, pull reverse release lever backwards (arrow A) and to the right to latch (arrow B). This allows the machine to pull back easily. Be certain brush is raised before transporting. To raise brush, pull brush lever backwards (arrow C) until it latches (Figure 2).

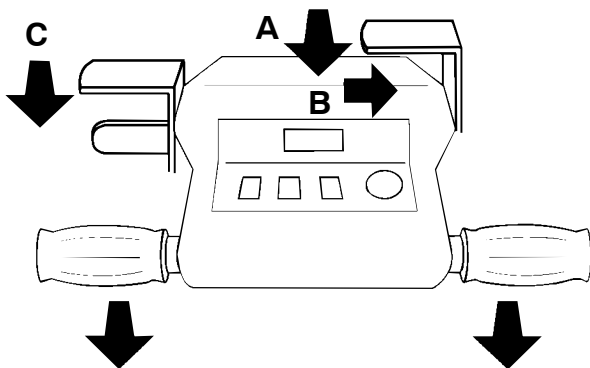

FIG. 2

FILLING SOLUTION TANK

Open fill port door at front of machine and fill with 106 liters (28 gal) of hot water, 60°C (140°F) maximum, and add a recommended liquid cleaning solution to proper dilution ratio (Figure 3).

FOR SAFETY: When using machine, follow mixing instructions on chemical containers.

⚠ WARNING: Do Not Use Flammable Liquids Or Operate Machine In Or Near Flammable Liquids, Vapors Or Combustible Dusts.

ATTENTION: If using powered cleaning chemicals, mix prior to adding. Wait until completely dissolved before pouring into solution tank.

ATTENTION: Always use separate buckets to fill and empty machine. Dirty water in solution tank will clog solution pump system.



FIG. 3

ADJUSTING CONTROL GRIP HEIGHT

Adjust control grip height to a comfortable operating height (three settings). To adjust, squeeze two levers under console together to raise or lower control grip (Figure 4).



FIG. 4

CONNECTING MACHINE TO POWER SOURCE

1. Connect equipped extension cord to short pigtail cord on machine.
2. Plug extension cord into a grounded power outlet (Figure 5).

FOR SAFETY: Do not operate machine unless cord is properly grounded.

FOR SAFETY: Do not operate machine with the use of additional extension cords. Only use manufacturer's extension cord equipped with machine which has proper capacity and is grounded.

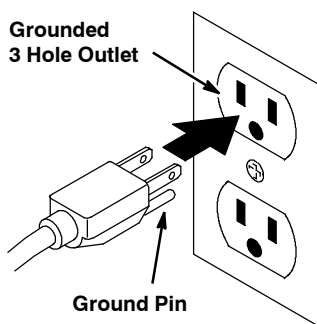

FIG. 5

⚠ WARNING: Do Not Operate With Damaged Power Cord. Do Not Modify Plug. Unplug power Cord Before Servicing Machine.

If the supply cord is damaged or broken, it must be replaced by the manufacturer or it's service agent or a similarly qualified person in order to avoid a hazard.

3. Attach belt clip to power cord and to your belt (Figure 6).



FIG. 6

PRE- OPERATION CHECKS

1. Vacuum the floor and remove any debris.
2. Inspect the power cord for damage. Replace immediately if damaged.
3. Check that the spray bar is installed.
4. Inspect the spray tips for proper spray pattern (See MACHINE MAINTENANCE).

CLEANING CARPET

FOR SAFETY: Do not operate machine unless operator manual is read and understood.

⚠ WARNING: Do Not Pick Up Flammable Materials Or Reactive Metals.

⚠ WARNING: Do Not Use Flammable Liquids Or Operate Machine In Or Near Flammable Liquids, Vapors Or Combustible Dusts.

1. Turn on main power switch.
2. Select cleaning mode. Position cleaning mode switch towards "INTERIM CLEANING" or "RESTORATIVE CLEANING" (Figure 7).



FIG. 7

RESTORATIVE CLEANING: Use this mode to restore heavily soiled carpet areas. This mode disperses 3.8 liters (1 gal) of solution per minute and recommends that you clean at a slower pace. The restorative cleaning mode must be performed on a regular basis in order for the interim cleaning mode to be effective.

INTERIM CLEANING: Use this mode for routine light cleaning. This mode disperses 2.6 liters (0.7 gal) of solution per minute and allows you to clean at a faster pace which will provide less drying time. The interim cleaning mode will be ineffective if the restorative cleaning mode is not performed on a regular basis.

OPERATION

3. Turn vacuum switch on.
4. Lower brush by depressing thumb latch and moving lever forward (Figure 8).



FIG. 8

5. Turn pump switch on.

NOTE: Pump and brush are activated by the control grips.

6. To begin cleaning, rotate control grips forward and adjust speed control knob according to specific cleaning mode (Figure 9):

RESTORATIVE CLEANING:

15 M (50 ft) per minute.

INTERIM CLEANING:

30 M (100 ft) per minute.



FIG. 9

7. Observe brush pressure meter while cleaning, it should read in the “Best Cleaning Results” range (See ADJUSTING BRUSH HEIGHT).
8. Watch level of foam build-up in recovery tank. If excessive foam appears, pour a quality defoamer chemical into recovery tank.

ATTENTION: Do not allow foam to enter float shut-off screen. Foam will damage vacuum motor. Damage caused by foam is not covered by warranty.

9. Turn pump switch off just before stopping to vacuum up excess solution.
10. Check remaining solution in solution tank when cleaning. To check, look at solution tank level indicator at rear of machine. Each mark on hose equals 22 Liters (5 gals) of solution (Figure 10).



FIG. 10

11. To pull machine backwards, engage reverse lever.
12. Work away from the wall outlet and power cord to prevent cord damage.

FOR SAFETY: When using machine, do not run machine over cord, do not pull machine by plug or cord, do not pull cord around sharp edges or corners, do not unplug by pulling on cord and do not handle plug with wet hands.

13. To stop the machine, position the machine on a level surface and gradually release the control grips.
14. After cleaning, perform the Daily Maintenance procedures (See MACHINE MAINTENANCE).

OPERATING PRE- SPRAY WAND

When cleaning, pre-spray traffic areas and spots using built-in spray wand. To activate wand, turn on main power and pump switches. Remove wand from holder, unlock trigger and spray where needed (Figure 11).



FIG. 11

ADJUSTING BRUSH HEIGHT

1. Lower brush.
2. Rotate speed control knob to slowest setting.
3. Turn main power switch on.
4. Rotate control grips forward and hold them.
5. While reading brush pressure meter, turn brush height adjustment knob until meter reads in the "Best Cleaning Results" range (Figure 12).



FIG. 12

CIRCUIT BREAKERS

The machine is equipped with two circuit breakers located on control housing at rear of machine.

1. Brush motor is protected by a 1.5 amp. circuit breaker. If breaker should trip, adjust brush height or remove any obstruction in brush. Reset breaker button.

FOR SAFETY: Before leaving or servicing machine, turn off machine and unplug from wall outlet.

2. Drive motor is protected by a 2.5 amp. circuit breaker. If breaker trips, allow motor to cool then reset circuit breaker button to resume or contact service center.

NOTE: When cleaning on inclines, always clean moving downward, never upward. Never climb inclines that exceed 5 degrees, machine circuit breaker may trip or damage may occur.

ACCESSORY TOOL SETUP AND OPERATION (OPTION)

The optional accessory tools allow you to clean upholstery and areas that the machine is unable to clean, such as alcoves, stairs, corners and small rooms.

For a complete list of accessory tools see the OPTIONS section in this manual

NOTE: When cleaning upholstery, always check cleaning instructions sewn in the furniture by manufacturer.

1. Vacuum area before cleaning.
2. Disconnect vacuum hose from recovery dome and replace with optional extension vacuum hose. Connect optional solution hose to quick disconnect located on top of tank. Then connect optional accessory tool to hoses (Figure 13).

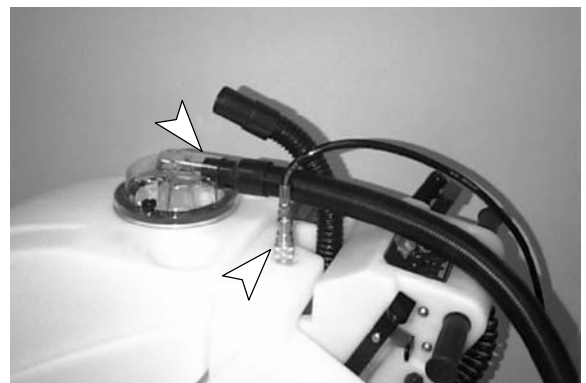

FIG. 13

3. Turn on "Main", "Vacuum" and "Pump" switches.

OPERATION

4. To clean, place tool on area to be cleaned, squeeze trigger and pull tool backwards (Figure 14).

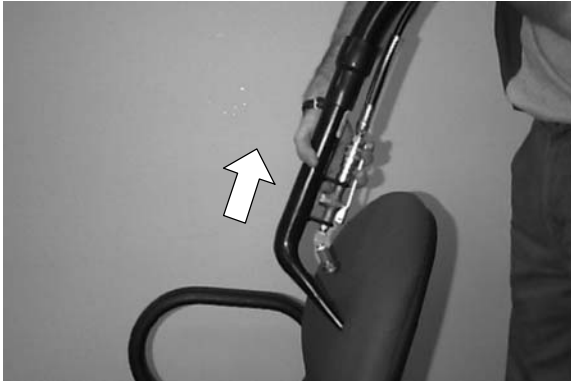

FIG. 14

⚠ WARNING: Flammable materials or reactive metals can cause an explosion or fire. Do not pick up.

5. Overlap strokes to avoid streaking.

NOTE: When cleaning upholstery, use as little cleaning solution as possible and avoid over wetting.

DRAINING TANKS

When finished cleaning, the recovery tank and solution tank should be drained and cleaned.

FOR SAFETY: Before leaving or servicing machine, turn off machine and unplug cord from wall outlet.

1. To drain recovery tank, push machine to a drain sink or floor drain and unhook drain hose from rear of machine. Unscrew T-handle from drain hose and drain tank (Figure 15).



FIG. 15

2. Remove recovery tank dome and rinse out tank. You can use the spray wand to rinse out recovery tank. Be careful not to spray water into standpipe screen (Figure 16).



FIG. 16

3. To drain solution tank, place machine over a drain sink or floor drain, pull solution tank level indicator hose off hose barb and drain (Figure 17).



FIG. 17

MACHINE MAINTENANCE

To keep machine in good working condition, simply follow machine's daily, weekly and monthly maintenance procedures.

FOR SAFETY: Before leaving or servicing machine, stop on level surface, turn off machine and unplug cord from wall outlet.

ATTENTION: Contact an Authorized Service Center for machine repairs. Machine repairs performed by other than an authorized person will void the warranty

DAILY MAINTENANCE (EVERY 4 HOURS OF USE)

1. Drain and rinse out recovery tank and recovery dome.
2. Remove float shut-off screen and clean. Screen is located in recovery tank (Figure 18).



FIG. 18

3. Drain solution tank. To drain, disconnect the solution tank level indicator hose at rear of machine (Figure 19).



FIG. 19

4. Remove any carpet strands or other debris from brush.
5. Remove any debris lodged inside vacuum pick-up head.
6. Inspect pigtail cord, cord grip and detachable power cord for damage. Replace immediately if damaged.
7. Clean machine housing with an all purpose cleaner and damp cloth.

WEEKLY MAINTENANCE (EVERY 20 HOURS OF USE)

1. Inspect spray tips for proper spray pattern:
 - a. Engage the reverse release lever to keep machine stationary (Figure 20).



FIG. 20

- b. Lower brush/pickup head and remove detachable spray bar from brush base. Do not disconnect bar from quick coupler (Figure 21). Raise brush after removing spray bar.
- c. Turn the main power and pump switches on.
- d. Holding the spray bar off the floor, briefly rotate control grips and observe spray pattern. Pattern should fan out evenly across the width of the spray bar (Figure 21).



FIG. 21

- e. Clean or replace defective twist-out spray tips if necessary (See MONTHLY MAINTENANCE).
2. Tighten hose cuffs and inspect hose for damage.

OPERATION

3. Remove bowl filter located underneath machine at front and clean screen. Make sure solution tank is empty before removing filter (Figure 22).

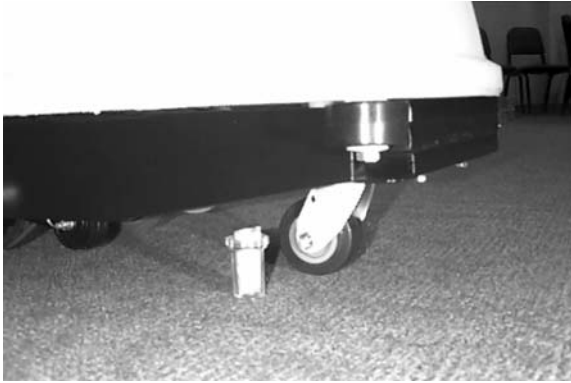

FIG. 22

MONTHLY MAINTENANCE (EVERY 80 HOURS USE)

1. Flush pump system with an acetic acid solution to dissolve alkaline chemical buildup. Follow instructions below:
 - a. Pour 1L (24 oz.) of an acetic acid solution in solution tank with 13L (3 gal) warm water.

FOR SAFETY: When using machine, follow mixing and handling instructions on chemical containers.

- b. Place machine over floor drain and engage reverse release lever.
 - c. Operate pump for 2 to 3 minutes.
 - d. Allow solution to remain in system overnight in above freezing temperatures.
 - e. Next day, drain solution and run 13L (3 gal) of clean water through system to flush out impurities.
2. Remove spray bar from machine by disconnecting quick coupler. Remove quick release spray tips from spray bar and soak spray tips in an acetic acid solution for up to 6 hours. Do not use pointed objects to unplug tips, damage will occur (Figure 23).

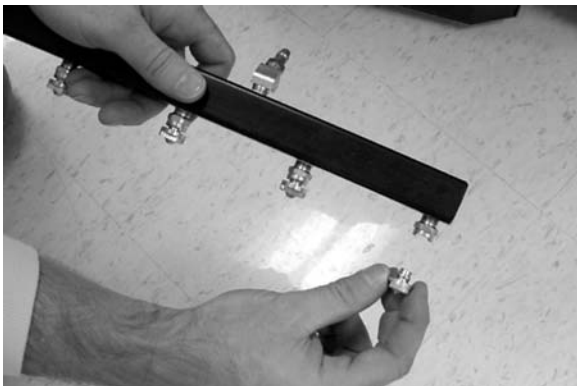

FIG. 23

3. Lubricate wheels and caster with a water resistant grease.
4. Inspect machine for water leaks.
5. Inspect machine for loose screws.
6. Check tension of drive belt. Drive belt must be properly adjusted to eliminate any slippage. (See ADJUSTING DRIVE BELT).

NOTE: Belt may slip if wet.

QUARTERLY MAINTENANCE (EVERY 250 HOURS OF USE)

Inspect motors for carbon brush wear. Replace brushes when worn to a length of 10 mm (0.38 in) or less. Contact an Authorized Service Center for carbon brush inspection.

FOR SAFETY: When servicing machine, all repairs must be performed by a qualified service person.

ADJUSTING DRIVE BELT

FOR SAFETY: When servicing machine, unplug cord from wall outlet.

1. Carefully lay machine on its left side.
2. Loosen (4) bolts on drive motor (Figure 24).
3. Loosen locknut on belt tension bolt.
4. Turn belt tension bolt clockwise to tighten belt.
5. Retighten locknut on belt tension bolt. Do not over tighten belt; belt should flex 12.7 mm (0.50 in) at center. For proper adjustment, belt should represent diagram below.

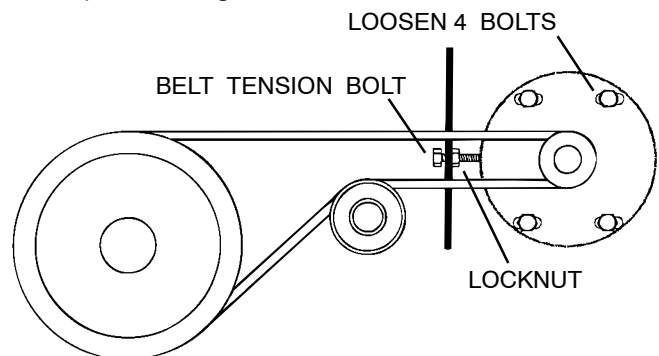

FIG. 24

TRANSPORTING MACHINE

When transporting the machine by use of trailer or truck, be certain to follow tie-down procedures below:

FOR SAFETY: When using machine, go slow on inclines and slippery surfaces.

1. Raise brush base.
2. Load the machine using a recommended loading ramp.
3. Position the front of the machine up against the front of the trailer or truck. Once machine is positioned, lower the brush base and disengage the reverse release lever.
4. Place a block behind each drive wheel to prevent machine from rolling.
5. Place tie-down straps over the top of the machine to prevent it from tipping. It may be necessary to install tie-down brackets to the floor of your trailer or truck.

FOR SAFETY: When transporting machine, use a recommended ramp when loading/unloading into/off truck or trailer, use tie-down straps to secure machine to truck or trailer.

STORING MACHINE

1. Drain and rinse tanks thoroughly.
2. Store the machine in a dry area with the brush base in the raised position.
3. Remove the recovery tank dome to promote air circulation.

ATTENTION: If storing the machine in freezing temperatures, be certain to drain tanks, purge pump and remove the solution tank filter located under the machine at front. Damage due to freezing temperatures is not covered by warranty.

⚠ WARNING: Do Not Use Outdoors. Do Not Expose To Rain. Store Indoors.

RECOMMENDED STOCK ITEMS

Refer to Standard Parts section for recommended stock items. Stock Items are clearly identified with a Bullet preceding the parts description. See example below:

Ref.	Part No.	Description	Qty.
1	701103	ASSEMBLY, STANDPIPE	1
2	180613	● FLOAT, SHUTOFF	1
3	230197	NIPPLE	1
4	101714	● GASKET	1
5	210240	NUT, FLANGED	1

TROUBLE SHOOTING

PROBLEM	CAUSE	SOLUTION
No power	Faulty main power switch.	Contact Service Center.
	Loose power cord connection	Connect power cord.
	Faulty power supply cord.	Replace power supply cord.
	Building circuit breaker has tripped.	Determine cause and reset circuit breaker in building.
Brush motor does not operate	Pump switch is not activated.	Turn on pump switch.
	Control grips are not rotated.	Rotate control grips.
	Brush circuit breaker has tripped.	Remove obstruction from brush and reset brush circuit breaker button.
	Faulty brush motor or wiring.	Contact Service Center.
	Carbon brushes worn.	Contact Service Center.
	“Roll Switch 1” (left side) faulty or needs adjustment.	Contact Service Center.
	Loose or broken belt.	Replace, or contact Service Center.

OPERATION

TROUBLE SHOOTING - continued

PROBLEM	CAUSE	SOLUTION
Brush motor operates, but brush does not spin	Loose or broken brush drive belt.	Tighten or replace belt.
	Loose set screws on belt pulleys.	Tighten set screws.
Vacuum motor does not operate	Vacuum switch not turned on.	Turn on vacuum switch.
	Faulty vacuum switch or wiring.	Contact Service Center.
	Faulty vacuum motor or wiring.	Contact Service Center.
	Vacuum motor thermal overload activated.	Remove obstruction and wait 20 minutes for motor to cool.
Poor vacuum recovery	Recovery tank is full.	Empty recovery tank.
	Float shut-off screen inside recovery tank is clogged.	Remove screen and clean.
	Pickup head is clogged with debris.	Remove debris, use coat hanger.
	Vacuum hose connections/cuffs are loose or hose is defective.	Push hose cuffs firmly onto connections. Replace hose if damaged.
	Vacuum hose is clogged with debris.	Remove clogged debris.
	Dome gasket is defective.	Replace gasket.
	Drain hose plug is loose.	Tighten drain plug.
	Recovery tank dome is loose.	Tighten dome screws.
	Vacuum motor is loose.	Contact Service Center.
Reverse release lever is hard to engage	Belt tension too tight.	Readjust belt tension (See Maintenance instructions).
Pre-spray wand does not spray	"Main" and "Pump" switches not turned on.	Turn "Main" and "Pump" switches on.
	Trigger locked on wand.	Unlock trigger.
	Spray tip on wand plugged.	Remove spray tip and clean with an acetic acid solution.
	Bowl filter screen plugged.	See Weekly Maintenance
	Loose or broken wiring.	Contact Service Center.
	Faulty MAIN or PUMP switch.	Contact Service Center.
	Faulty solution pump.	Contact Service Center.
Machine does not spray solution	MAIN switch is not turned on.	Turn on MAIN switch.
	PUMP switch is not turned on.	Turn on PUMP switch.
	Control grips not twisted.	Twist control grips forward to start spray, brush and drive motors.
	Bowl filter screen plugged.	See Weekly Maintenance.
	Spray tips plugged.	See Monthly Maintenance.
	Loose or broken wiring.	Contact Service Center.
	Faulty solenoid valve.	Contact Service Center.
	Faulty MAIN or PUMP switch.	Contact Service Center.

TROUBLE SHOOTING - continued

PROBLEM	CAUSE	SOLUTION
Machine does not spray solution	Roll Switch 1 faulty or needs adjustment.	Contact Service Center.
	Faulty solution pump.	Contact Service Center.
Machine does not move when rotating control grips	Reverse release lever engaged.	Disengage reverse release lever.
	MAIN switch not turned on.	Turn on MAIN switch.
	Speed control knob turned to slowest setting.	Turn speed control knob to desired setting.
	2.5 amp. circuit breaker tripped.	Push breaker button to reset.
	Loose drive belt.	Tighten belt (See Maintenance).
	Broken drive belt.	Replace belt (See Maintenance).
	Wet drive belt.	Dry belt off.
	Loose or broken wiring.	Contact Service Center.
	Roll Switch 1 or 2 faulty or needs adjustment.	Contact Service Center.
	Speed Control Board faulty or needs adjustment.	Contact Service Center.
	Faulty drive motor or wiring.	Contact Service Center.
Worn carbon brushes in drive motor.	Contact Service Center.	

SPECIFICATIONS

MODEL	Falcon™ 2800 Plus
LENGTH	1295 mm (51 in)
WIDTH	559 mm (22 in)
HEIGHT	1092 mm (43 in)
WEIGHT	109 Kg (241 lb)
SOLUTION TANK CAPACITY	106 L (28 Gal)
RECOVERY TANK CAPACITY	68 L (18 Gal)
SPEED CONTROL	Variable Fwd.
CLEANING SPEED (MAX)	465 m ² (5,000 sq ft) per hour (Deep Extraction Mode) 697 m ² (7,500 sq ft) per hour (Light Extraction Mode)
CLEANING PATH WIDTH	559 mm (22 in)
SOLUTION PUMP	6.9 bar (100 psi) max., 120V, 1A, 1 gpm
BRUSH MOTOR	.16hp, 1800 rpm, 120V, 1A, 90W
VACUUM MOTOR	2hp, 3- stage 5.7 in, 120V, 13A
WATER LIFT / AIR FLOW	3480 mm (137 in) / 2.86 m ³ h (101 cfm)
DECIBEL RATING AT OPERATOR'S EAR, INDOORS ON CARPET	81dB(A)
POWER CORD LENGTH	23 m (75 ft)

ELECTRICAL DIAGRAMS

120V WIRING DIAGRAM

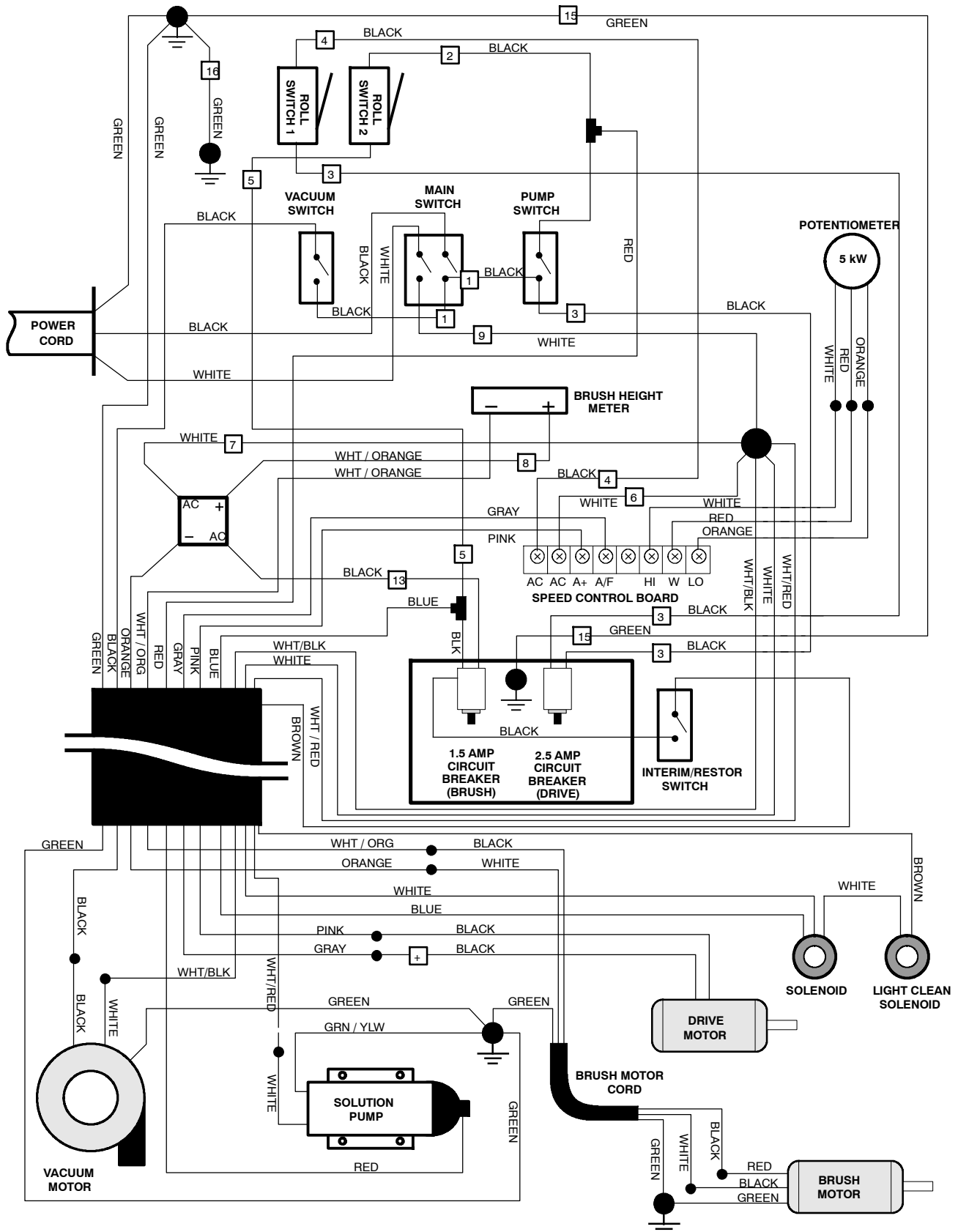

120V LADDER DIAGRAM

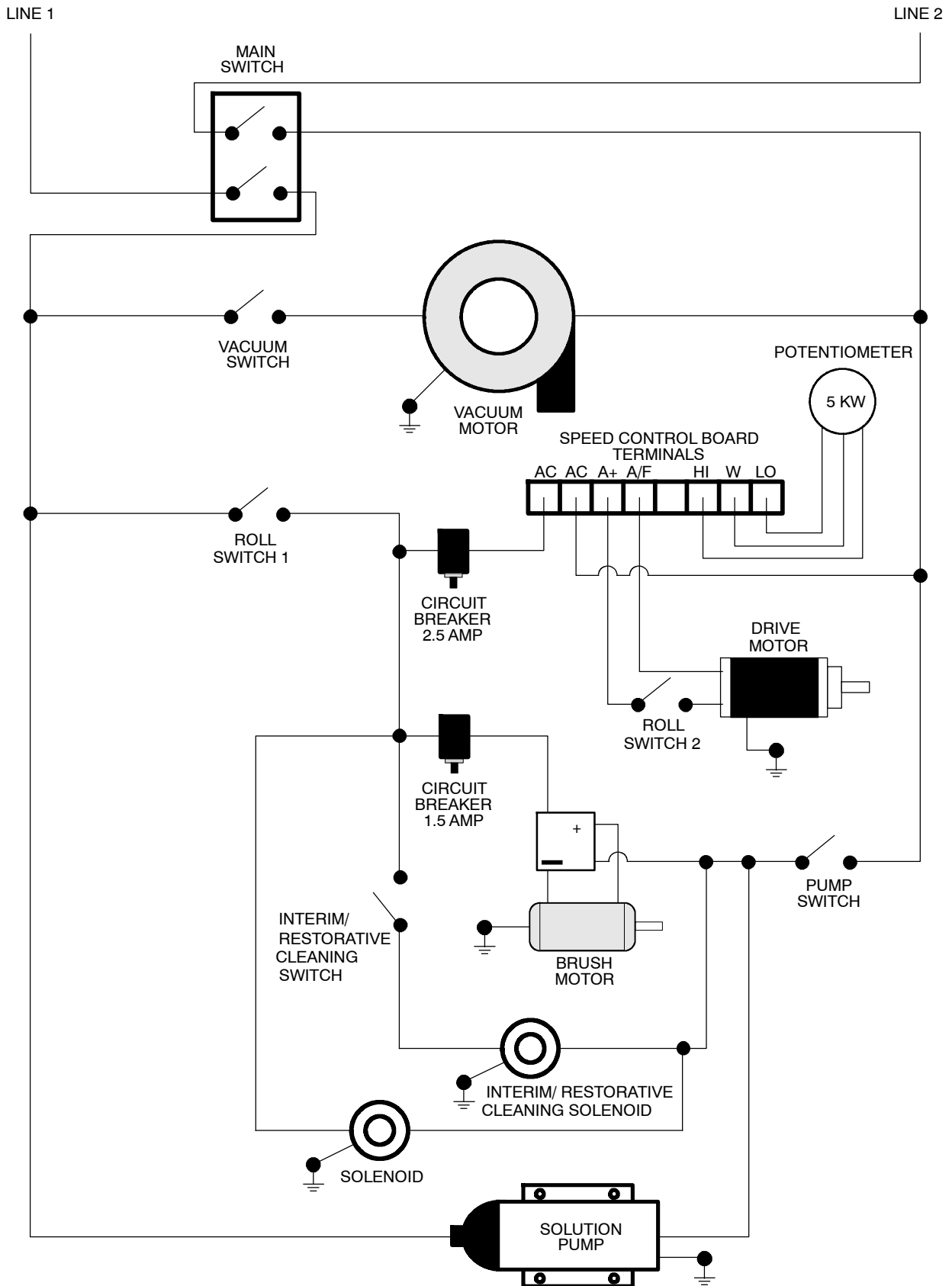

RECOVERY TANK GROUP

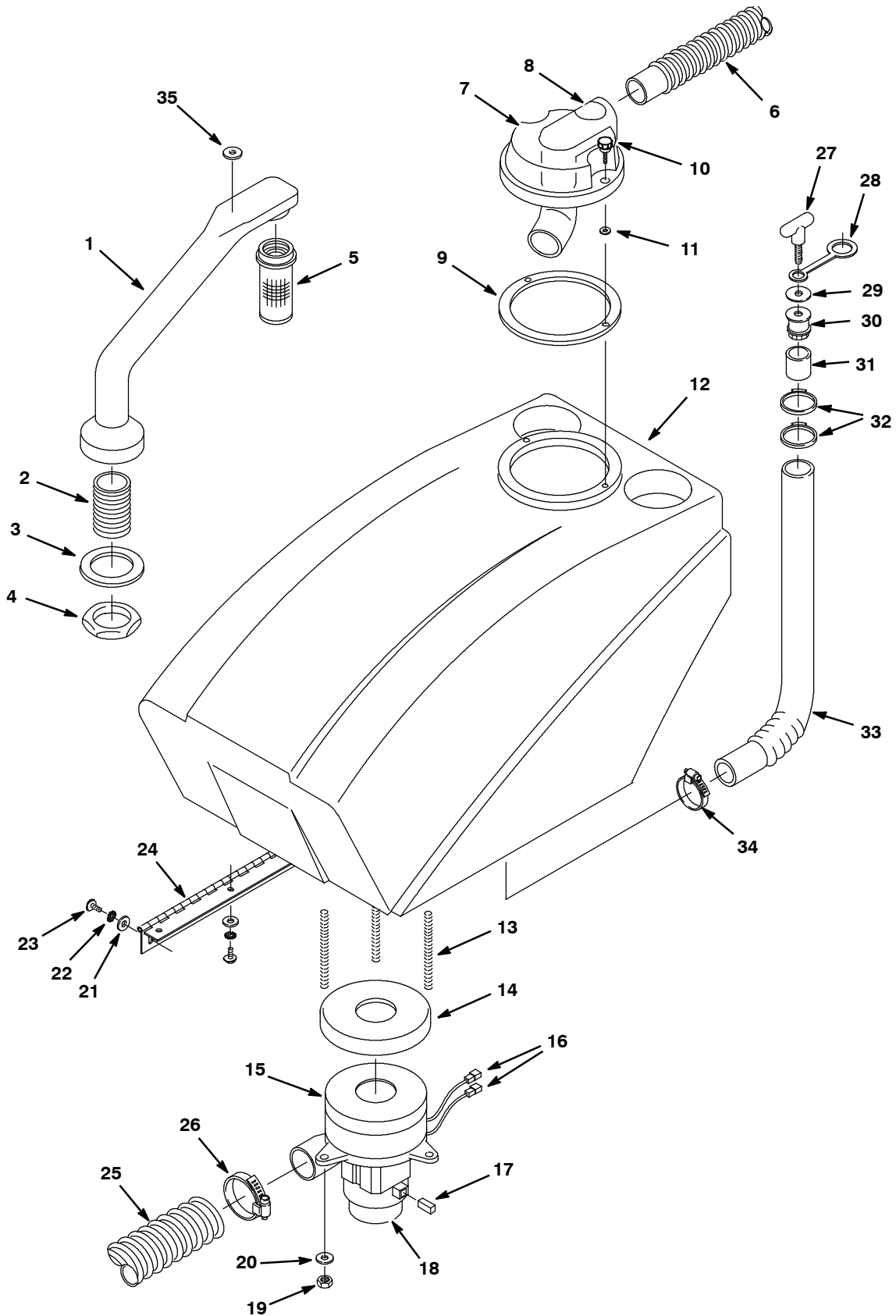

RECOVERY TANK GROUP

REF	PART #	DESCRIPTION	QTY.
▽	100162	ASM., STANDPIPE W/NIPPLE	1
▲ 1	100759	STANDPIPE	1
▲ 2	606088	NIPPLE, 1- 1/2 PVC	1
3	101714	●GASKET, WASTE AIR CHAMBER	1
4	210240	NUT, FLANGED METAL	1
5	180613	●FLOAT, SHUT- OFF SCREEN	1
6	160413	●HOSE, VAC INTAKE	1
▽	700683	ASM, DOME W/ELBOW	1
▲ 7	100112	DOME, VACUUM	1
▲ 8	120399	LABEL, DO NOT ALLOW FOAM	1
▲ 9	100042	●GASKET, RECOVERY DOME	1
▲ 10	240217	KNOB, RND .25- 20 BLK	2
▲ 11	140037	WASHER, .218X.437X.031 NYLON	2
12	608844	TANK, RECOVERY GREEN	1
13	140227	STUD, 1/4- 20X5	3
14	100038	●GASKET, VAC MOTOR 5.7	1
▽ 15	130996	●MOTOR, VAC 5.7/3 STG 120V	1
▲ 16	130133	TERMINAL, MALE .25 RED	2
▲ 17	602741	●CARBON BRUSHES 2/PK	1

REF	PART #	DESCRIPTION	QTY.
▲ 18	130487	●HOUSING, MOTOR, FAN, VENT	1
19	41169	NUT, HEX LOCK .25- 20 NYLON	3
20	140000	WASHER, FLAT 1/4"	3
21	140000	WASHER, FLAT 1/4"	9
22	140015	WASHER, LOCK SPLIT 0.31	9
23	02991	SCREW, HEX .31- 18X0.75	9
24	230418	HINGE, TANK	1
25	160487	●HOSE, VAC 2"X34" WHT	1
26	11531	CLAMP, HOSE, WORMDRIVE, 1.06-2.00D, .56W	1
▽	701061	●ASM., DRAIN HOSE STOPPER	1
▲ 27	230831	KNOB, DRAIN HOSE	1
▲ 28	230882	●STRAP, DRAIN HOSE STOPPER	1
▲ 29	140056	WASHER, FLAT .38 FENDER	1
▲ 30	140955	PLUG, DRAIN HOSE	1
31	140921	SLEEVE, DRAIN HOSE	1
32	140072	CLAMP, HOSE 1- 9/16" STEPLESS	2
33	160414	HOSE, DRAIN	1
34	140307	CLAMP, HOSE 3/4 TO 1- 3/4	1
35	100029	GASKET, TUBE	1

▽ ASSEMBLY

▲ INCLUDED IN ASSEMBLY

● RECOMMENDED STOCK ITEMS

SOLUTION TANK GROUP

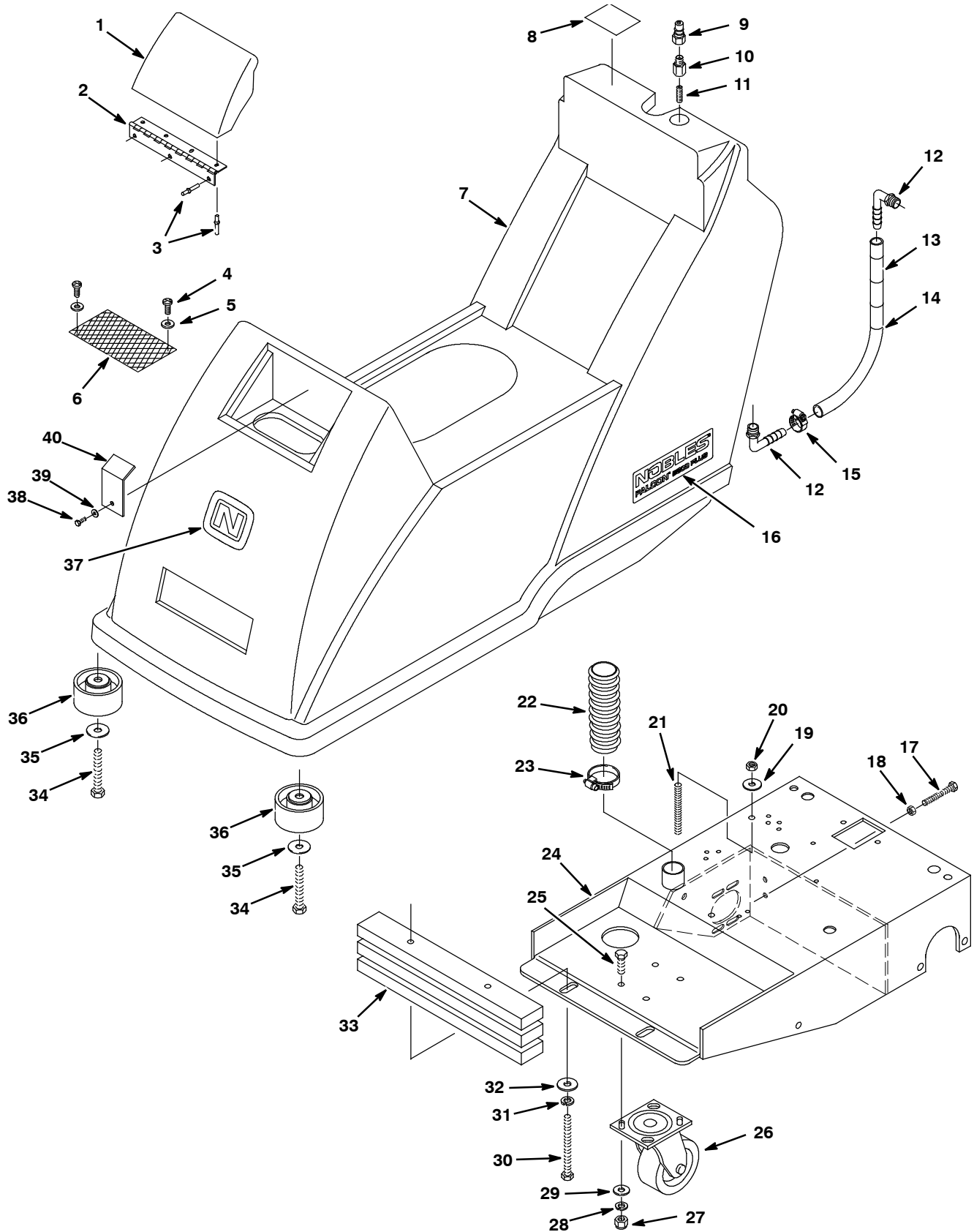

SOLUTION TANK GROUP

REF	PART #	DESCRIPTION	QTY.
1	608284	COVER, SOLUTION GREEN	1
2	611068	HINGE, COVER	1
3	140706	RIVET, POP	9
4	3701.6	SCREW, #6X3/8 PANPHL	2
5	140032	WASHER, #6 FLAT	2
6	602529	SCREEN, FILTER	1
7	608840	TANK, SOLUTION GREEN	1
8	1026384	LABEL, WARNING [EXPL,FIRE,SHK EN/FR/ES]	1
9	150933	●PLUG, QCK CPLR BRS - SER 60	1
10	150000	FITTING, BRS STR PM04/PF04	1
11	150615	FITTING, 1/4MX7/8 CLSNIP	1
12	150425	FITTING, E 3/8MX1/2H 90 NY	2
13	069764611	HOSE, CLEAR .50IDX24"	1
14	130040	TIE, WIRE 6"X12 NYLON	4
15	630369	CLAMP, HOSE .50- 1.1	1
16	1035598	LABEL, MODEL [NOBLES FALCON 2800 PLUS]	2
17	140231	SCREW, 3/8X1- 1/2 HEX	1
18	01692	NUT, HEX, STD, .38- 16, SS	1
19	140028	WASHER, FLAT 3/8"	1
20	140525	NUT, HEX 3/8- 16	1
21	140342	STUD, SPRING TENSION	1

REF	PART #	DESCRIPTION	QTY.
22	160487	●HOSE, VAC 2"X34" WHITE	1
23	140308	CLAMP, HOSE 1- 5/16 TO 2- 1/4	1
24	608836	WELDMENT, CHASSIS	1
25	140202	SCREW, 3/8- 16X1.0	4
26	103002	●CASTER, SWIVEL 4"	1
27	140525	NUT, HEX 3/8- 16	4
28	140017	WASHER, SPLITLOCK 0.38- S/S	4
29	140028	WASHER, FLAT 3/8"	4
30	2949.30	SCREW, 3/8- 16X3- 3/4	2
31	140017	WASHER, SPLITLOCK 3/8"	2
32	140028	WASHER, FLAT 3/8"	2
33	230462.BK	PLATE, COUNTER WEIGHT, BLACK	3
34	140234	SCREW, 1/2- 13X2- 1/2 HXHDCP	2
35	140008	WASHER, FLAT .570X1.28X0.75	2
36	103037	●WHEEL, 3.0DX1.50W	2
37	1034637	LABEL, FRONT, 3.50 [NOBLES ICON]	1
38	140221	SCREW, 5/16- 18X1- 1/4 HXHDCP (CSA MODEL ONLY)	1
39	25732	WASHER, 0.36B 1.25D .093 FLAT (CSA MODEL ONLY)	1
40	612038	PLATE, LOCK (CSA MODEL ONLY)	1

● RECOMMENDED STOCK ITEMS

DRIVE WHEEL GROUP

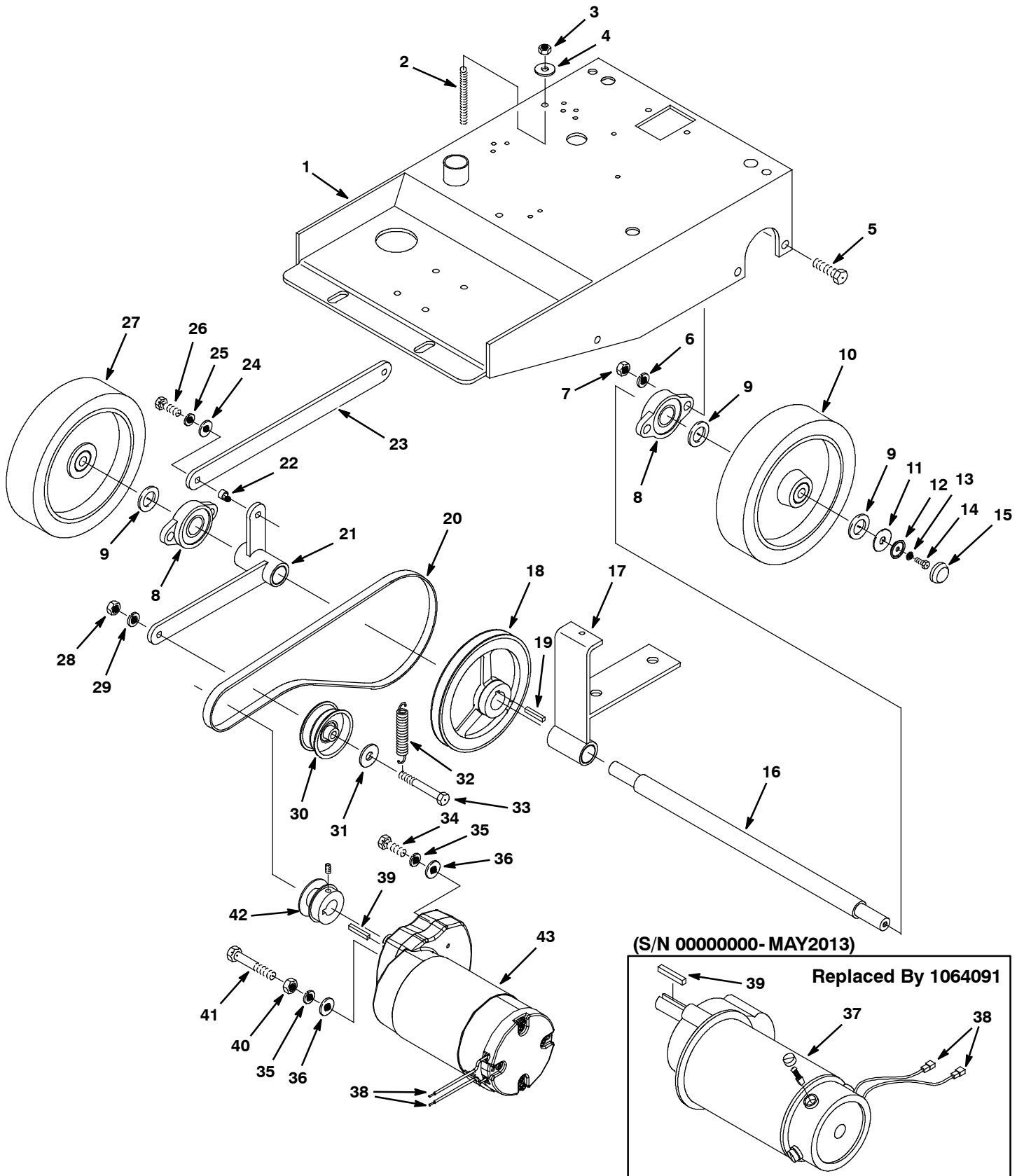

(S/N 00000000- MAY2013)
 Replaced By 1064091

DRIVE WHEEL GROUP

REF	PART #	DESCRIPTION	QTY.
1	608836	WELDMENT, CHASSIS	1
2	140342	STUD, SPRING TENSION	1
3	140525	NUT, HEX 3/8- 16	1
4	140028	WASHER, FLAT 3/8"	1
5	611048	SCREW, HEX 3/8- 16X1- 1/4	4
6	140017	WASHER, SPLIT LOCK 3/8"	4
7	01692	NUT, HEX, STD, .38- 16, SS	4
8	140128	BEARING, FLANGE	2
9	140047	WASHER, 1.246X.754X.062	4
10	611137	●WHEEL, ASM LEFT CLUTCH	1
11	30013	WASHER, FLAT, 0.31, FENDR	2
12	140048	WASHER, 5/16" FOR 150210	2
13	140015	WASHER, SPLITLOCK 0.31	2
14	02991	SCREW, 5/16- 18X3/4	2
15	150210	PLUG, CAP- BLACK	2
16	230419	AXLE, DRIVE SHAFT	1
17	230404.BK	BRACKET, PIVOT BRUSH ASM	1
18	230762	PULLEY, 7/8" BORE AXLE	1
19	140632	KEY, .25X.25X1.00	1
20	230763	●BELT, V DRIVE COGGED	1
21	230759.BK	BRACKET, IDLER PIVOT	1
22	140136	BUSHING, .38X.50X.28	3
23	230757.BK	LINK, BELT DRIVE	1
24	140028	WASHER, FLAT	2

REF	PART #	DESCRIPTION	QTY.
25	140017	WASHER, LOCK 3/8	2
26	02994	SCREW, .38- 16X.75	2
27	611136	●WHEEL, ASM RIGHT CLUTCH	1
28	140545	NUT, JAM 3/8	1
29	140017	WASHER, LOCK	1
30	230764	PULLEY, IDLER	1
31	140028	WASHER, FLAT 3/8"	1
32	140345	SPRING, BELT TENSION	1
33	140225	SCREW, 3/8- 16X2 HXHDCP	1
34	02994	SCREW, .38- 16X.75	5
35	140017	WASHER, SPLITLOCK	4
36	140028	WASHER, FLAT 3/8"	4
▽ 37	613423	●MOTOR, ELECT 115VDC (BEFORE JUNE 2013)	1
▲	130508	●BRUSH, CARBON (BEFORE JUNE 2013)	4
38	130096	TERMINAL, BLADE MALE .25	2
39	140632	KEY, .25X.25X1.00	1
40	01692	NUT, HEX, STD, .38- 16, SS	1
41	140225	SCREW, 3/8- 16X2 HXHDCP	1
42	230761	PULLEY, 3/4" BORE MOTOR	1
▽ 43	1064091	●MOTOR, ELE, 115VDC 230RPM 1/3HP GEAR (AFTER MAY 2013)	1
▲	1069150	●BRUSH KIT, MOTOR (1 PKG = 4 BRUSHES) (AFTER MAY 2013)	1

▽ ASSEMBLY

▲ INCLUDED IN ASSEMBLY

● RECOMMENDED STOCK ITEMS

REAR PANEL LEVER GROUP

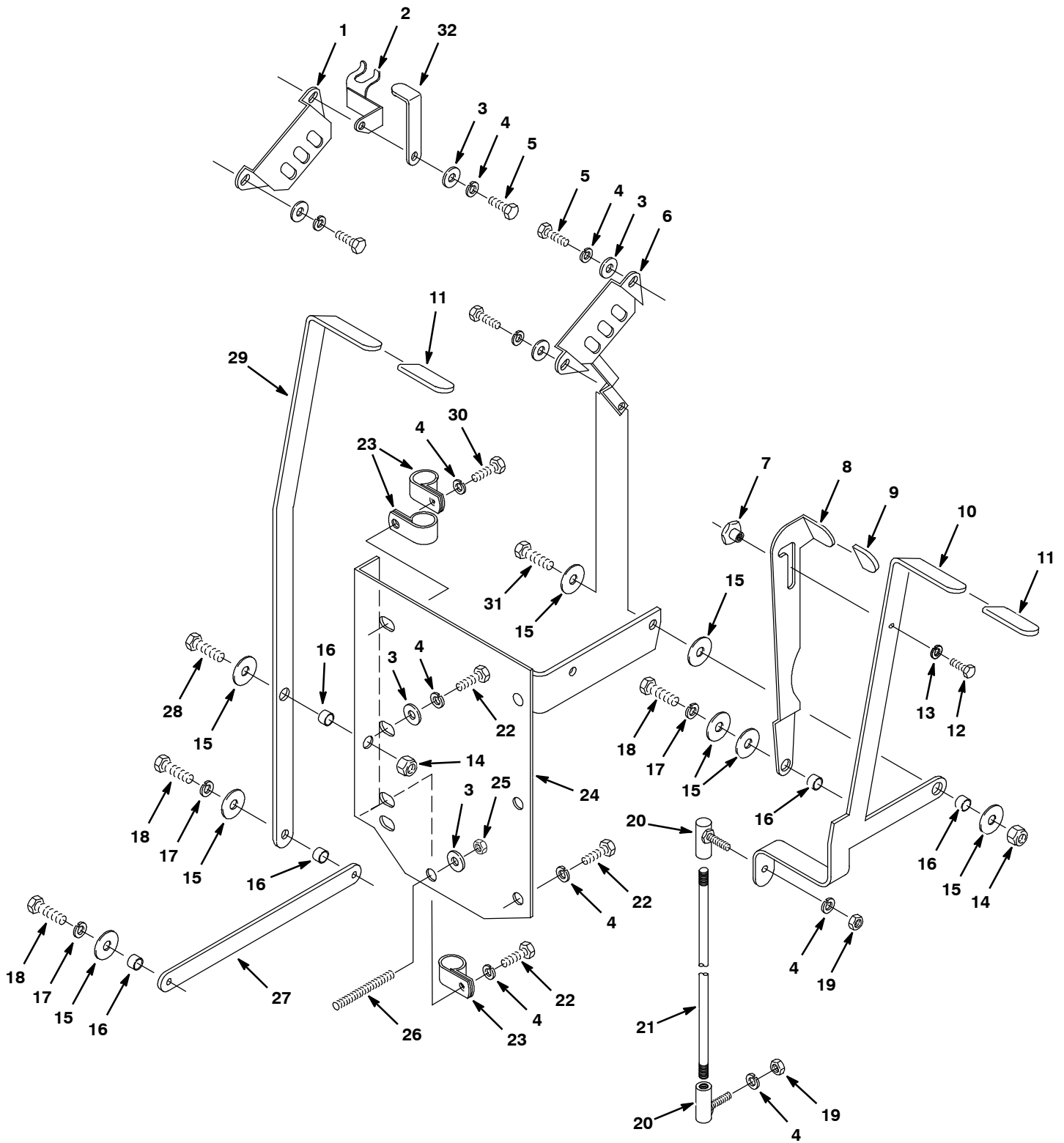

REAR PANEL LEVER GROUP

REF	PART #	DESCRIPTION	QTY.
1	230661	PLATE, LOCK CONTROL RH	1
2	611979	WELDMENT, DRAIN HOSE HNGR	1
3	140027	WASHER, FLAT 5/16"	8
4	140015	WASHER, SPLITLOCK	12
5	140885	SCREW, 1/4- 20X1/2 TRSPHL	4
6	230297	PLATE, LOCK CONTROL LH	1
7	230631	SPACER, SQUEEGEE LIFT	1
8	230659	LATCH, SQUEEGEE HANDLE	1
9	200817	●GRIP, HANDLE 1/4X1X2- 1/4	1
10	230472.BK	HANDLE, LIFT LEVER	1
11	200816	●GRIP, HANDLE, RUBBER	2
12	140259	SCREW, HXHDCP .25- 20X.62	1
13	140016	WASHER, LOCK .25	1
14	59156	NUT, HEX LOCK .38- 16 NL	2
15	140028	WASHER, FLAT 3/8"	8
16	140136	BUSHING, .38X.50X.28	5

REF	PART #	DESCRIPTION	QTY.
17	140017	WASHER, SPLIT LOCK 3/8"	3
18	02994	SCREW, HEX .38- 16X.75	3
19	140508	NUT, HEX 5/16- 24- ZINC	2
20	140119	JOINT, BALL - LIFT ROD	2
21	230412	ROD, LIFT BRUSH ASM	1
22	02991	SCREW, HXHDCP .31- 18X.75	4
23	140314	CLAMP, INSULATED 3/4"	3
24	230787.BK	WELDMENT, REAR PANEL, BLACK	1
25	01692	NUT, HEX, STD, .38- 16, SS	1
26	230413	ROD, PRESSURE SPRING	1
27	230757.BK	LINK, BELT DRIVE	1
28	140202	SCREW, 3/8- 16X1 HXHDCP	1
29	230760	BRACKET, REVERSE HANDLE	1
30	140219	SCREW, HEX .31- 18X1.00	1
31	611048	SCREW, HEX .38- 16X1.25	1
32	230883	BRACKET, REVERSE LATCH	1

● RECOMMENDED STOCK ITEMS

CONTROL CONSOLE GROUP

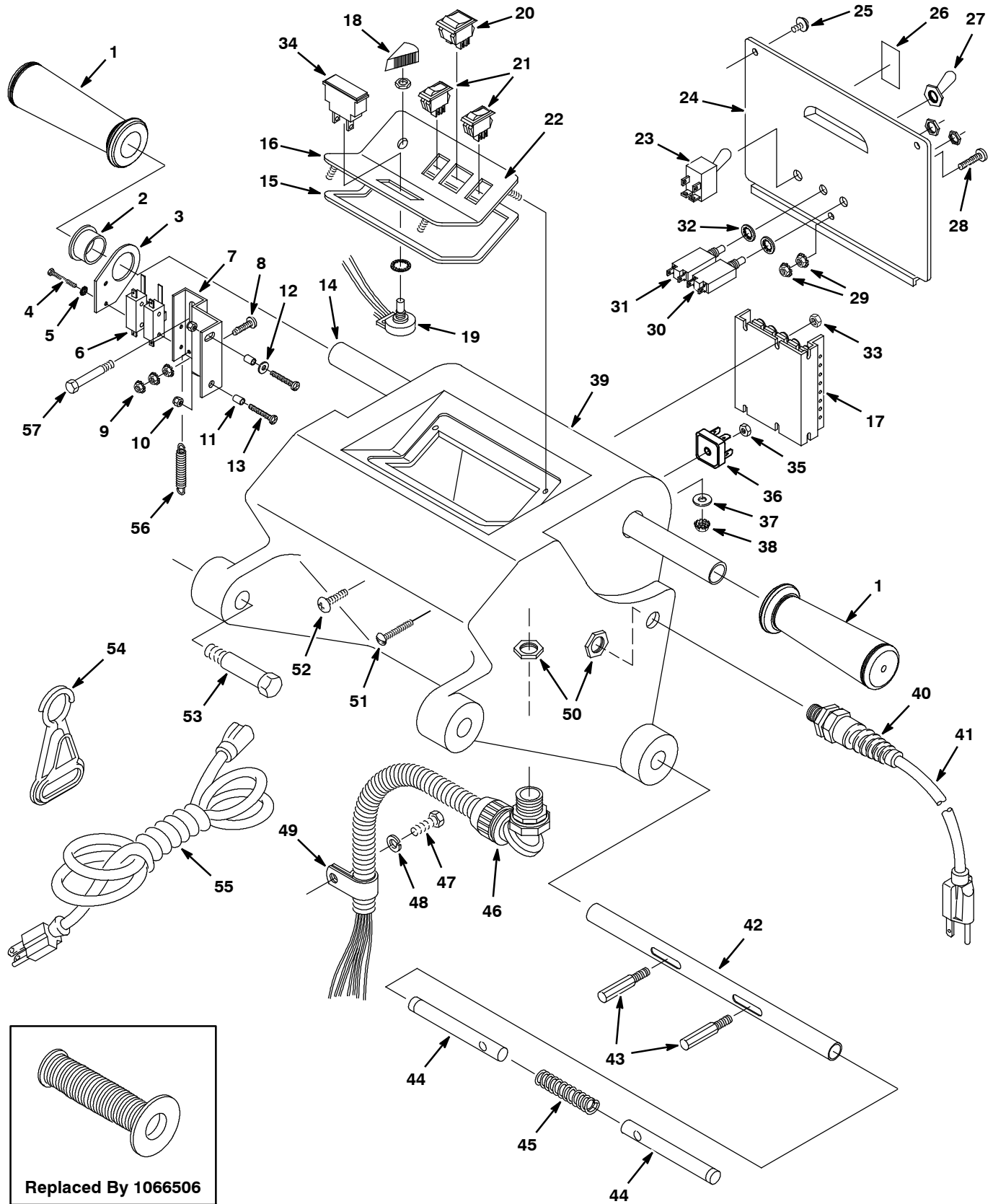

CONTROL CONSOLE GROUP

REF	PART #	DESCRIPTION	QTY.
1	1066506	●GRIP, HANDLE RND	2
2	605351	BUSHING, 7/8 10 BLACK	1
3	27098	BRACKET, SWITCH	1
4	140830	SCREW, 6- 32X1- 5/8 PANPHL	2
5	140019	WASHER, LOCK EXT #6	2
6	614003	●SWITCH, SNAP, W/ BUMP	2
7	25671	MOUNT, SWITCH	1
8	140900	SCREW, 10- 24X3/4 TRSPHL	1
9	140519	NUT, KEP 10- 24	3
10	41169	NUT, HEX LOCK .25- 20 NYLON	2
11	140143	SPACER, .25X.50X.56 NYLON	2
12	140000	WASHER, FLAT 1/4"	1
13	140846	SCREW, 1/4- 20X1- 1/2 RNDPHL	2
14	604402	TUBE, HANDLE	1
15	100057	●GASKET, CONSOLE	1
16	230465.BK	PANEL, CONTROL	1
▽ 17	9010132	●CIRCUITBOARD KIT, INSTALL	1
▲ 18	130770	●KNOB, SPEED CONTROL	1
▲ 19	130283	●POTENTIOMETER	1
20	602669	●SWITCH, ROCKER DPST 20A	1
21	130717	●SWITCH, ROCKER ON/OFF	2
22	120594	DECAL, DASH	1
23	130726	SWITCH, TOGGLE	1
24	608838	PLATE, CONTROL COVER	1
25	140197	SCREW, 10- 24X3/8 TRS PHL SEM	2
26	607209	LABEL, FLOW CONTROL	1
27	130990	●BOOT, RUBBER SWITCH BLACK	1
28	140900	SCREW, 10- 24X3/4 TRSPHL	1
29	140519	NUT, KEP 10- 24	2

REF	PART #	DESCRIPTION	QTY.
30	578337000	●BREAKER, CIRCUIT 1.5 AMP	1
31	130746	●BREAKER, CIRCUIT 2.5 AMP	1
32	140022	WASHER, INT LCK 3/8	2
33	140552	NUT, KEP 10- 24 NYLON	2
34	130019	●METER, AMP	1
35	140336	NUT, HEX 10- 24 NYLON	1
36	130304	RECTIFIER, BRIDGE- 600V 15AMP	1
37	140000	WASHER, FLAT, 1/4"	4
38	140519	NUT, KEP 10- 24	4
39	608278	CONTROL HOUSING GREEN	1
40	130167	GRIP, STRAIN- RELIEF 1/2NPT	1
41	130228	●CORD, 14/3 X 34" YELLOW	1
42	230613	TUBE, HANDLE ADJUSTMENT	1
43	230649	PIN, HANDLE ADJUSTMENT	2
44	230648	PIN, HANDLE ADJUSTMENT LOCK	2
45	140415	SPRING, LOCK PIN	1
46	608837	●HARNES, WIRING	1
47	140219	SCREW, HEX .31- 18X1.00	1
48	140015	WASHER, LOCK SPLIT .31	1
49	140314	CLAMP, INSULATED 3/4" ID	1
50	140504	NUT, CONDUIT LOCK 1/2" NPT	2
51	140335	SCREW, RND 10- 24X1" SLOT NY	1
52	140890	SCREW, 10- 24X1/2 TRSPHL	2
53	140241	SCREW, 5/8X2 SHLDR	2
54	130176	●CLIP, CORD STRAIN RELIEF YLW	1
55	130229	●CORD, 14/3X75' YELLOW SMTH	1
56	605294	SPRING	1
57	140222	SCREW, 5/16- 18X2 HXHDCP	1

▽ ASSEMBLY

▲ INCLUDED IN ASSEMBLY

● RECOMMENDED STOCK ITEMS

PICK-UP HEAD GROUP

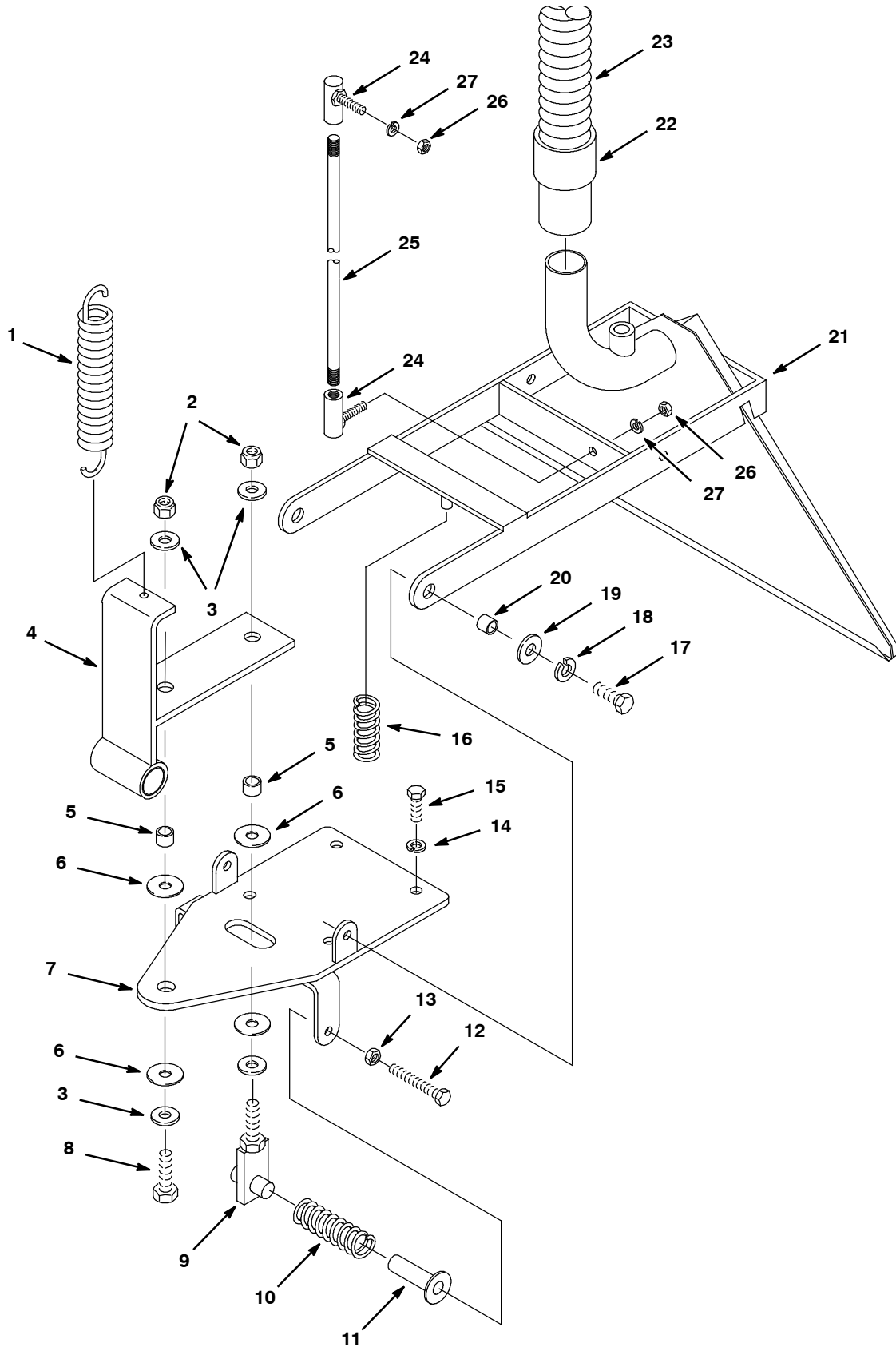

PICK-UP HEAD GROUP

REF	PART #	DESCRIPTION	QTY.
1	140423	SPRING, BRUSH PRESSURE	1
2	140516	NUT, LOCK- NYLON INSERT 1/2	2
3	140008	WASHER, FLAT .570X1.28X.075	4
4	230404.BK	BRACKET, PIVOT BRUSH ASM	1
5	140139	SLEEVE, .625DX.25L	2
6	140040	WASHER, POLY 1/2X1- 3/8	4
7	230405.BK	BRACKET, BRUSH MNT ASM, BLK	1
8	140204	SCREW, 1/2- 13X1- 1/2 HXHDCP	1
9	230463	BOLT, PIVOT SPRING	1
10	140337	SPRING, COMPRESSION PIVOT	2
11	230464	PIN, PIVOT SPRING	2
12	140233	SCREW, 3/8- 16X1- 3/4 HXHDCP	2
13	01692	NUT, HEX, STD, .38- 16, SS	2
14	140015	WASHER, SPLIT LOCK 0.31	4

REF	PART #	DESCRIPTION	QTY.
15	02991	SCREW, .31- 18X.75 HEX	4
16	140407	SPRING, COMPRESSION	1
17	02994	SCREW, .38- 16X.75	2
18	140017	WASHER, SPLITLOCK 3/8"	2
19	140028	WASHER, FLAT 3/8"	2
20	140136	BUSHING, 3/8 X 1/2	2
21	604959	NOZZLE, CARPET PICK-UP, BLK	1
22	160413	●HOSE, VAC INTAKE	1
23	160486	●CUFF, HOSE 1.50 BLK	1
24	140119	JOINT, BALL - LIFT ROD	2
25	230412	ROD, LIFT BRUSH ASM	1
26	140508	NUT, HEX 5/16- 24	2
27	140015	WASHER, SPLIT LOCK 0.31	2

● RECOMMENDED STOCK ITEMS

BRUSH BASE GROUP

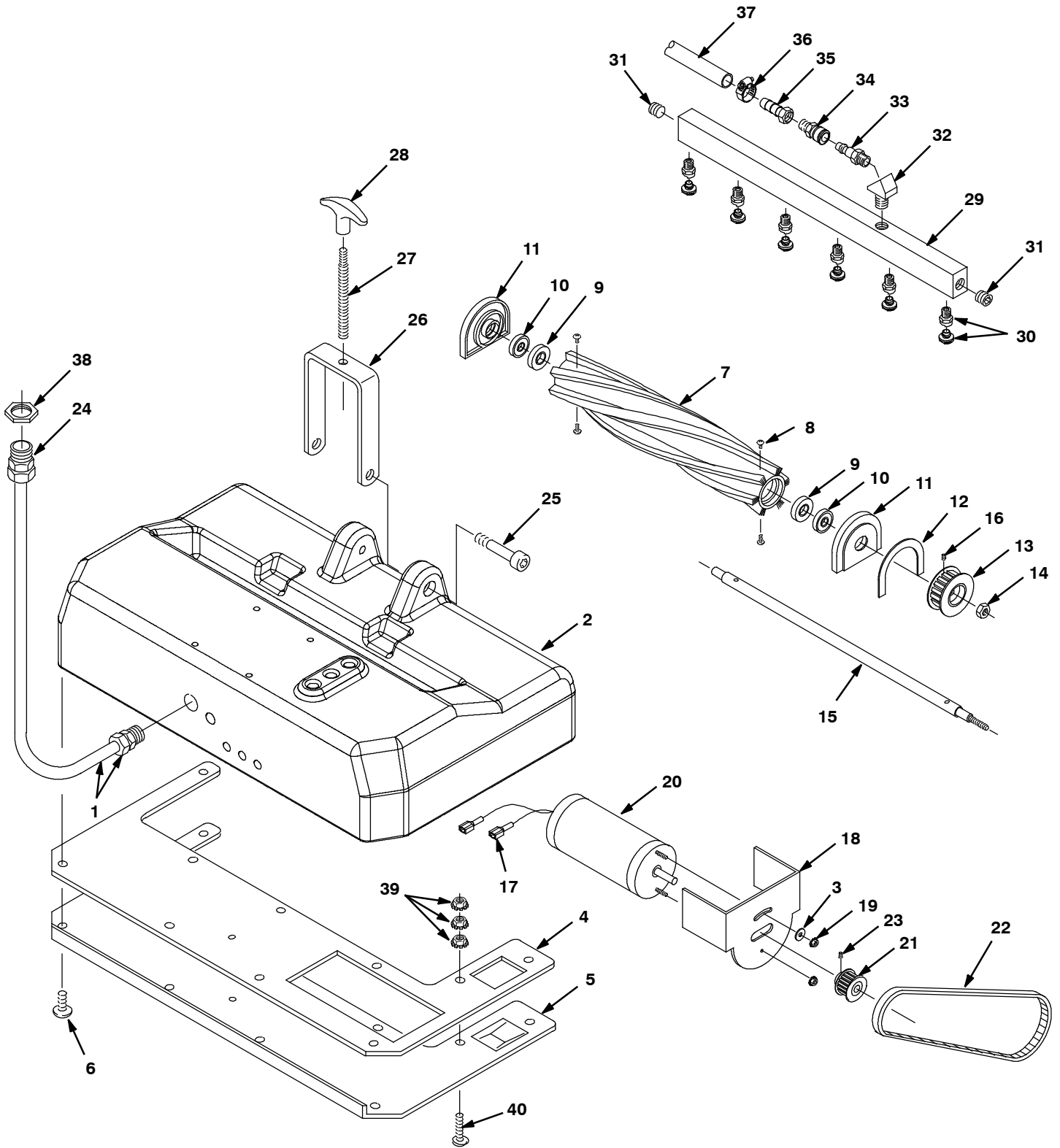

BRUSH BASE GROUP

REF	PART #	DESCRIPTION	QTY.	
1	130290	●CORD, 18/3X36" BLACK	1	
2	602780	BASE, 22" BLACK	1	
3	200315016	WASHER, FLAT M5.3X15.0X1.6	1	
4	100157	●GASKET, BASE PLATE 22"	1	
5	611919	PLATE, BASE 22"	1	
6	140197	SCREW, 10- 24X3/8 TRSPHL SEM	11	
▽	700422	●ASM., BRUSH	1	
▲	7	240063	●BRUSH, SCRUB 22" CYLINDER	1
▲	8	24672	SCREW, .25- 20X0.75 HEX	4
▲	9	100049	●SEAL, BRUSH BEARING	2
▲	10	140125	●BEARING, BRUSH	2
▲	11	230261	●BLOCK, BRUSH BEARING	2
▲	12	100005	●GASKET, BEARING BLOCK	1
▲	13	230408	PULLEY, BRUSH	1
▲	14	140548	NUT 5/16 FINJAM	1
▲	15	230406	SHAFT, BRUSH 22"	1
▲	16	140859	SCREW, SET 1/4- 20X1/4	1
17	130096	TERMINAL, MALE DSCNT 16- 14	2	
18	230411	BRACKET, BRUSH MOTOR	1	
19	140518	NUT, HEX 10- 32 KEP	2	
20	1063949	●MOTOR, ELE, 115VDC, .125HP (SN 10566253-)	1	
20	1019015	●MOTOR, ELE, 115VDC, .125HP, 3.0D (REPLACED BY 1063949) (SN 00000000- 10566252)	1	
21	230410	●PULLEY, MOTOR	1	

REF	PART #	DESCRIPTION	QTY.	
22	230409	●BELT, TIMING 18.75"	1	
23	140859	SCREW, SET 1/4- 20X1/4	1	
24	130190	GRIP, CORD 3/8N NYLON BLK	1	
25	140564	BOLT, SHOULDER 3/8 X 3/4	2	
26	230365.BK	BRACKET, HEIGHT ADJ, BLK	1	
27	230479	STUD, HGT ADJ 3.5"	1	
28	240194	●KNOB, TEE 5/16- 18 FEMALE	1	
▽	700423	ASM., SPRAYBAR 22"	1	
▲	29	230407	MANIFOLD, SOL. SPRAYBAR 22"	1
▲	30	201011	FITTING, JET #80015	6
		201013	TIP, REPLACEMENT FOR #80015	1
		201015	SEAL, SPRAY NOZZLE	1
▲	31	150208	FITTING, 1/8M PLUG BRS SKHD	2
▲	32	150422	FITTING, 1/8M X 1/8F ELB STRT45	1
▲	33	150921	FITTING, BRS QDC 1/8M SER 5	1
34	150915	COUPLER, QCK 1/8 SER 5	1	
35	150520	FITTING, 1/8F X 1/8M BARB BRS	1	
36	54333	CLAMP, HOSE WORM 0.31 - 0.88D	1	
37	613434	HOSE, 1/4 X 2.0' GRAY LP	1	
38	140549	NUT, CONDUIT 3/8 LOCK	1	
39	140519	NUT, KEP 10- 24	3	
40	140900	SCREW, TRS 10- 24 X 3/4	1	

▽ ASSEMBLY

▲ INCLUDED IN ASSEMBLY

● RECOMMENDED STOCK ITEMS

PLUMBING GROUP

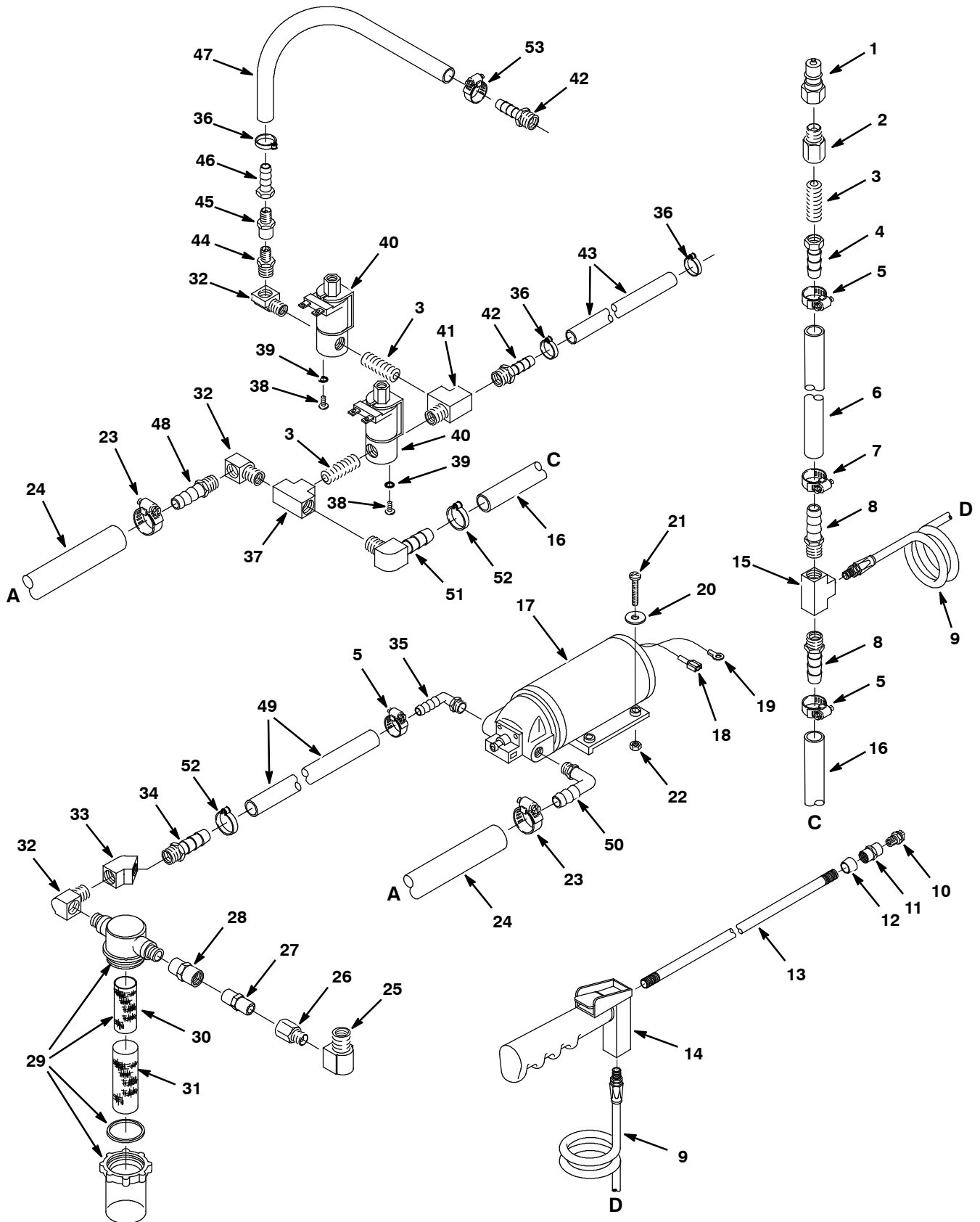

PLUMBING GROUP

REF	PART #	DESCRIPTION	QTY.
1	150933	●PLUG, QCK CPLR BRS - SER 60	1
2	150000	FITTING, BRS STR PM04/PF04	1
3	150615	FITTING, 1/4MX7/8 CLSNIP	3
4	150511	FITTING, 1/4FX3/8H HOSE BARB	1
5	54333	CLAMP, HOSE 0.31- 0.88D	3
∇	700664	●ASM, SPRAY WAND	1
▲ 6	609432	HOSE, 3/8 LP GRAY 1.083'	1
▲ 7	140301	CLAMP, HOSE 5/8ID EAR GALV.	1
▲ 8	150516	FITTING, 1/4M X 3/8H HOSE BARB	2
▲ 9	160132	●HOSE, 1/4ID X 12' BLK RECOIL	1
▲ 10	201000	●FITTING, 1/8 V- JET #80015	1
▲ 11	150307	COUPLING, 1/8F X 1/8F BRASS	1
▲ 12	240212	SPACER, TAPERED	1
▲ 13	230835	NIPPLE, 1/8NPT X 18" LONG	1
▲ 14	230986	GUN, SPRAY W/GRIP	1
▲ 15	150706	FITTING, 1/4 FPT TEE	1
16	609433	HOSE, 3/8"X32" LP GRAY	1
∇ 17	180103	●PUMP, 100 PSI, 120V	1
▲ 18	130096	TERMINAL, BLADE ML .25	1
▲ 19	130125	TERMINAL, RING #10	1
20	19066	WASHER, FLAT #10	2
21	140899	SCREW, RND 10- 24X1- 1/4 PHL	2
22	140552	NUT, HEX 10- 24 NYLON	2
23	63810	CLAMP, HOSE, WORMDRIVE, 0.56- 1.06D, .56W	2
24	607705	HOSE, 1/2"X24" RED	1
25	150420	FITTING, 3/8MX3/8F ELB 90°	1
26	150006	FITTING, 1/4FX3/8M BUSHING	1
27	150606	FITTING, BRS, STR, PM04/PM04 X 1.38L [NIP]	1

REF	PART #	DESCRIPTION	QTY.
28	150302	FITTING, BRS STR PF04/PF04	1
∇ 29	180619	●FILTER, SCREEN 80 MESH BOWL	1
▲ 30	180632	●STRAINER, INLINE FILTER	1
31	180638	●SLEEVE, FILTER 125 MESH	1
32	27048	FITTING, BRS, E90, PF04/PM04	3
33	150400	FITTING, 1/4"FX1/4F ELB 45°	1
34	150516	FITTING, BRS 1/4MX3/8H	1
35	150412	FITTING, PLST 3/8M X 3/8H 90° NY	1
36	140325	CLAMP, HOSE 1/2 EAR	3
37	150706	FITTING, 1/4 FPT TEE	1
38	140801	SCREW, 8- 32X3/8 TRSPHL	4
39	02938	WASHER, LOCK, INT, 08, SS	4
40	210033	●VALVE, SOLENOID, 120V 60HZ	2
41	150709	FITTING, BRS, TEE PF04/PF04/PM04	1
42	150515	FITTING, 1/4MX1/4H BARB BRS	2
43	609435	HOSE, PVC, BRD, 0.25ID 0.50OD 15"L, GRAY (160204)	1
44	150614	FITTING, REDUCER 1/4M X 1/8M	1
45	603517	VALVE, CHECK 1/8FPT X 1/8MPT	1
46	150520	FITTING, 1/8F X 1/4H BARB BRS	1
47	613537	HOSE, 1/4ID X 7/16OD X 1.083M	1
48	150517	FITTING, 1/4MX1/2H BARB	1
49	609434	HOSE, 3/8"X10.5" GRAY	1
50	150425	FITTING, E3/8MX1/2H 90° NYLON	1
51	150419	FITTING, 1/4MX3/8H ELB. 90 BRS	1
52	43844	CLAMP, HOSE, WORMDRIVE, 0.25- 0.62D, .31W	2
53	140301	CLAMP, HOSE 5/8ID EAR GALV.	1

∇ ASSEMBLY

▲ INCLUDED IN ASSEMBLY

● RECOMMENDED STOCK ITEMS

PUMP BREAKDOWN

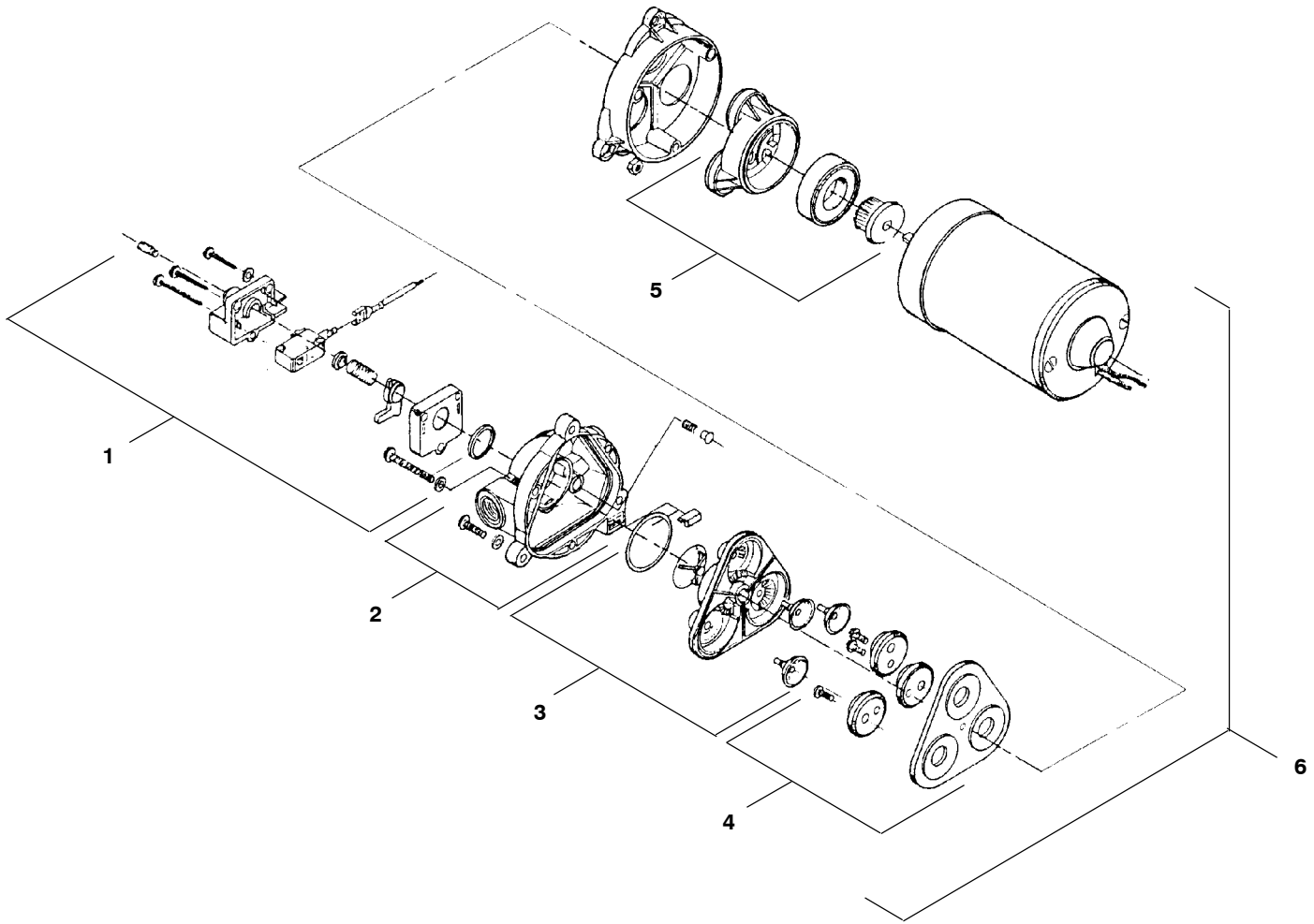

REF	PART #	DESCRIPTION	QTY.
1	190129	●KIT, SWITCH PRESSURE	1
	190172	●KIT, SWITCH VITON 80- 100 PSI	1
	190134	●KIT, SWITCH DIAPHRAGM	1
2	190128	●KIT, UPPER PUMP HOUSING	1
	190124	●KIT, REPLMT CHECK VALVE	1

REF	PART #	DESCRIPTION	QTY.
3	190171	●KIT, VITON VALVE	1
4	190131	●KIT, SHURFLO SERVICE	1
5	190130	●KIT, LOWER PUMP HOUSING	1
6	180103	●PUMP, 100 PSI 120V (COMPLETE)	1

● RECOMMENDED STOCK ITEMS

HOSES, SOLUTION AND VACUUM

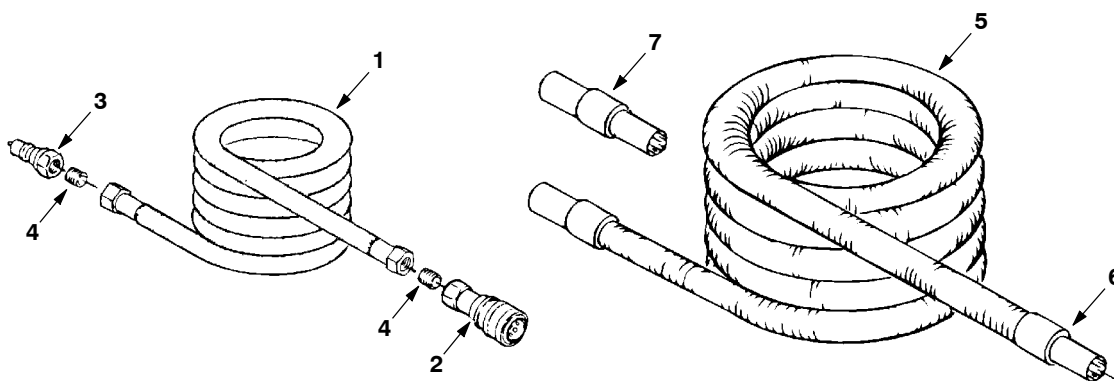

REF	PART #	DESCRIPTION	QTY.
▽ 1	160185	HOSE, SOLUTION 3/8X4.6M/15' (OPTIONAL)	1
	160186	HOSE, SOLUTION 3/8X7.6M/25' (STANDARD)	1
	160187	HOSE, SOLUTION 3/8X15.2M/50' (OPTIONAL)	1
▲ 2	150913	●FITTING, BRS, QDC, PF04, SER60	1
▲ 3	150933	FITTING, BRS, QDC, PM04, SER60	1
▲ 4	150615	FITTING, BRS, STR, PM04, CLOSE, T	2

REF	PART #	DESCRIPTION	QTY.
▽ 5	160400	HOSE, VACUUM 1- 1/2X4.6M/15' (OPTIONAL)	1
	160401	HOSE, VACUUM 1- 1/2X7.6M/25' (STANDARD)	1
	160402	HOSE, VACUUM 1- 1/2X15.2M/50' (OPTIONAL)	1
▲ 6	160430	●CUFF, HOSE 1- 1/2"	2
7	160451	●CONNECTOR, VAC HOSE 1- 1/2"	1
N/S	220040	●BAG, HOSE W/DRAW STRING (OPTIONAL)	1

▽ ASSEMBLY

▲ INCLUDED IN ASSEMBLY

● RECOMMENDED STOCK ITEMS

WAND GROUP, LOW PRESSURE, 13 in / 330 mm

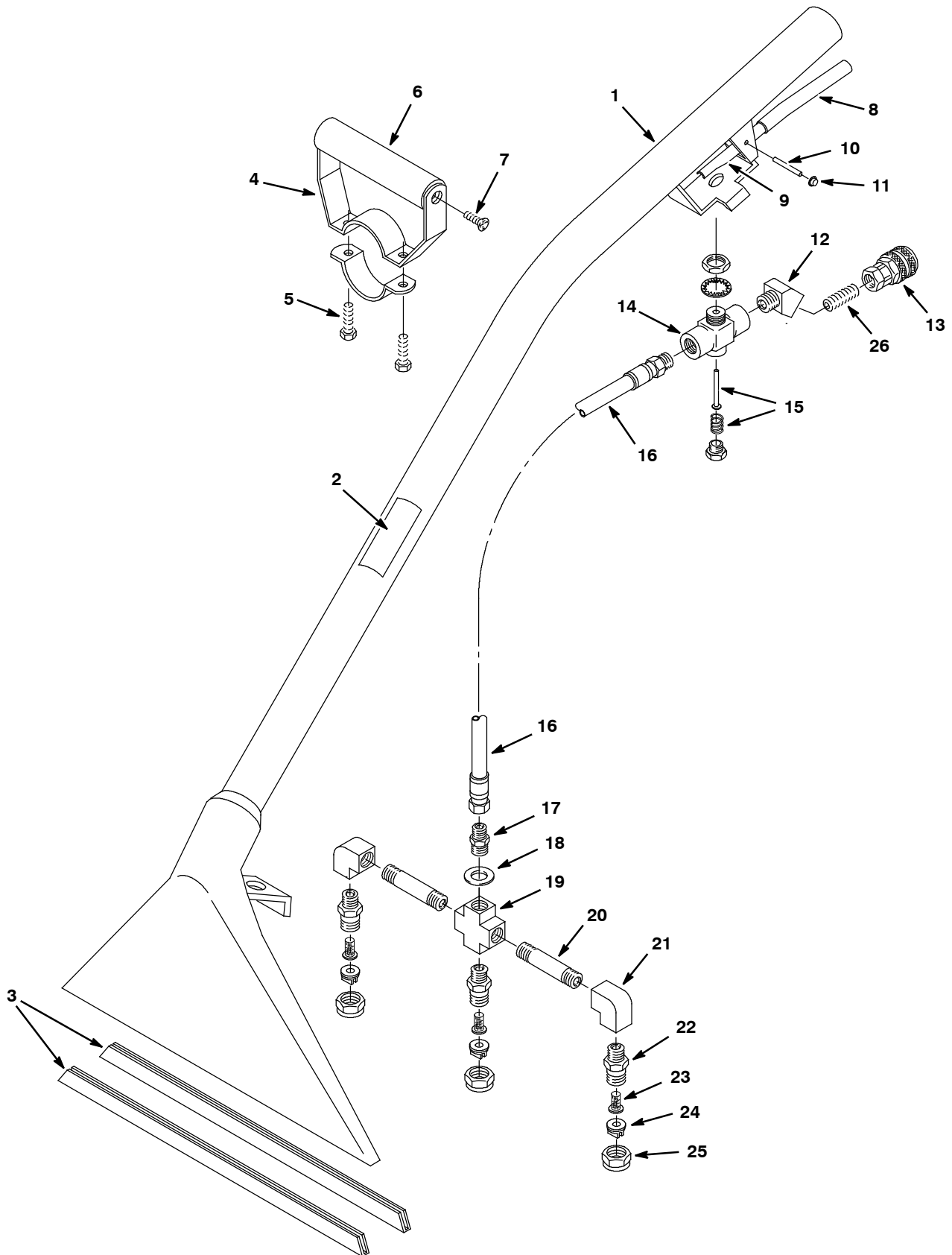

WAND GROUP, LOW PRESSURE, 13 in / 330 mm

REF	PART #	DESCRIPTION	QTY.
∇	600048	●ASM., WAND LOW PRESSURE	1
▲ 1	200403.BK	TOOL, FLOOR BLACK	1
▲ 2	120846	DECAL, LOW PRESSURE TOOL	1
▲ 3	200939	●SHOE, 330MM (13 IN) FLR TOOL	2
▲∇ 4	200927	GRIP, HAND ADJ. COMPLETE	1
▲▲ 5	140259	SCREW, 1/4- 20X5/8	2
▲▲ 6	200912	GRIP, HANDLE FOAM	1
▲▲ 7	140834	SCREW, 1/4- 20X5/8	2
▲ 8	200809	SLEEVE, HANDLE	1
▲ 9	200902	HANDLE, VALVE	1
▲ 10	140605	PIN, HANDLE	1
▲ 11	140520	NUT, 1/4 PUSH BLK	2
▲ 12	150403	FITTING, 1/4MX1/4F 45 STR	1
▲ 13	150913	●FITTING, 1/4F QD CPLR SER 60	1
▲∇ 14	210150	●VALVE, FLOW CONTROL	1

REF	PART #	DESCRIPTION	QTY.
▲▲ 15	190603	●KIT, VALVE PIN AND SPRING	1
▲ 16	160170	ASM, HOSE LOW PRESSURE	1
▲ 17	150606	FITTING, 1/4MX1- 3/8HEXNIP	1
▲ 18	140058	WASHER, .543X.875X.062 WAND	1
▲∇	700062	ASM., SPRAYBAR WO/TIPS	1
▲▲ 19	150700	CROSS, 1/4 FPT	1
▲▲ 20	150600	FITTING, 1/4MX2" NIPPLE	2
▲▲ 21	150401	FITTING, 1/4FX1/4F ELBOW 90	2
▲▲ 22	200993	SPRAY BODY, 1/4" MALE	3
▲ 23	200996	●FILTER, SCREEN 100 MESH	3
▲ 24	200964	●FITTING, TIP 11003 T- JET	3
▲ 25	200994	●CAP, SPRAY BODY	3
▲ 26	150615	FITTING, 1/4MX7/8 CLSNIP	1
N/S	200170	SQUEEGEE ASSY, 380MM/15.0, COMPLT (OPTION - FOR HARD FLOOR SURFACES)	1

∇ ASSEMBLY

▲ INCLUDED IN ASSEMBLY

● RECOMMENDED STOCK ITEMS

WAND GROUP, LOW PRESSURE, 16 in / 406 mm

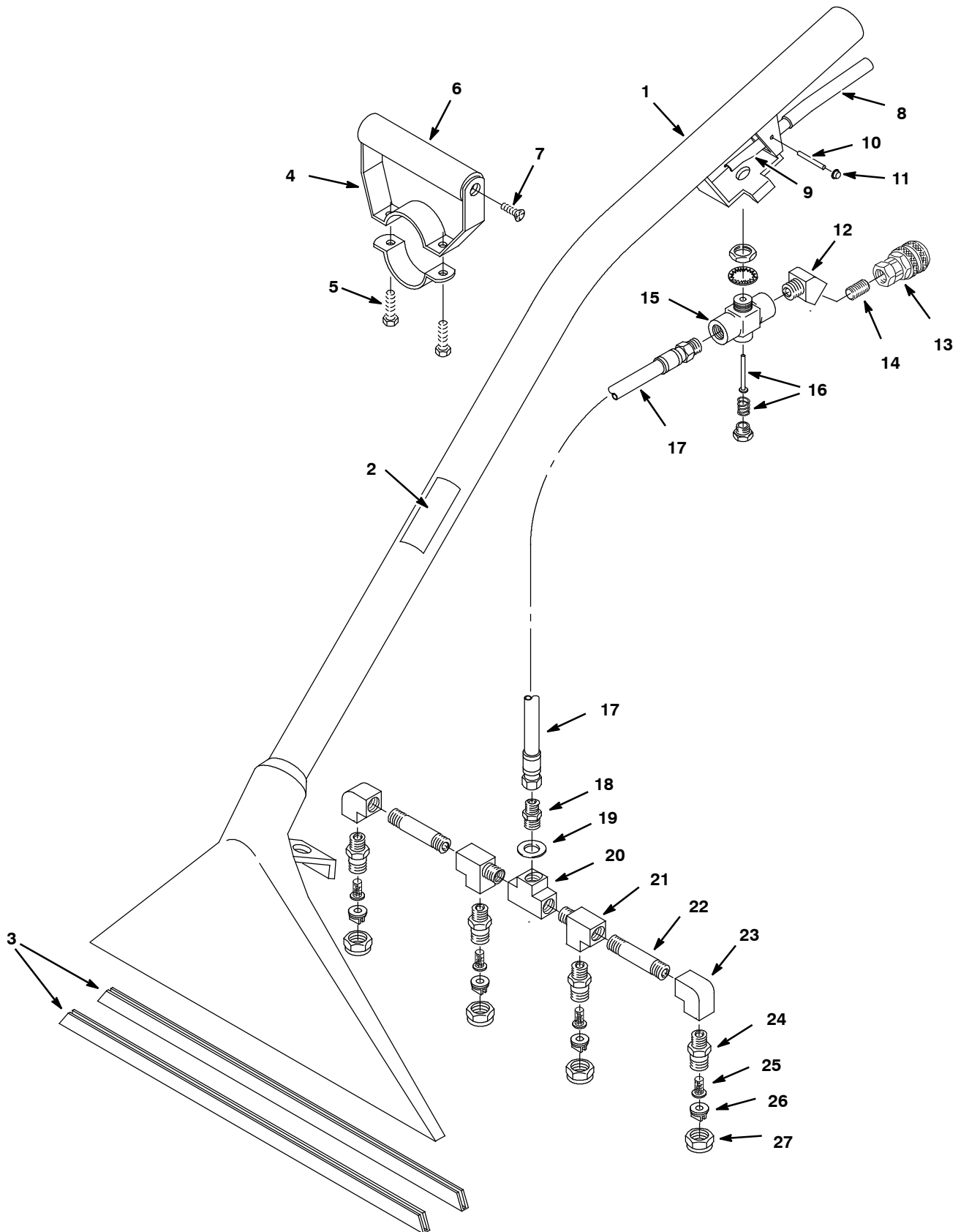

WAND GROUP, LOW PRESSURE, 16 in / 406 mm

REF	PART #	DESCRIPTION	QTY.
▽	200503	●ASM., FLOOR TOOL	1
▲ 1	200411.BK	TOOL, FLOOR 406MM (16 IN)	1
▲ 2	120846	DECAL, LOW PRESSURE TOOL	1
▲ 3	200956	●SHOE, 406MM (16 IN) FLR TOOL	2
▲▽ 4	200927	GRIP, HAND ADJ. COMPLETE	1
▲▲ 5	140259	SCREW, 1/4- 20X5/8	2
▲▲ 6	200912	GRIP, HANDLE FOAM	1
▲▲ 7	140834	SCREW, 1/4- 20X5/8	2
▲ 8	200809	SLEEVE, HANDLE	1
▲ 9	200902	HANDLE, VALVE	1
▲ 10	140605	PIN, HANDLE	1
▲ 11	140520	NUT, 1/4 PUSH BLK	2
▲ 12	150403	FITTING, 1/4MX1/4F 45 STR	1
▲ 13	150913	●COUPLER, SER. 60	1
▲ 14	150615	NIPPLE, CLOSE 1/4	1

REF	PART #	DESCRIPTION	QTY.
▲▽ 15	210150	●VALVE, FLOW CONTROL	1
▲▲ 16	190603	●KIT, VALVE PIN AND SPRING	1
▲ 17	160170	ASM, HOSE LOW PRESSURE	1
▲ 18	150606	FITTING, 1/4MX1- 3/8HEXNIP	1
▲ 19	140058	WASHER, .543X.875X.062 WAND	1
▲▽	700656	ASM., SPRAYBAR 16" WO/TIPS	1
▲▲ 20	150706	FITTING, 1/4F TEE	1
▲▲ 21	150709	FITTING, 1/4F X 1/4F X 1/4M	2
▲▲ 22	150600	FITTING, 1/4MX2" NIPPLE	2
▲▲ 23	150401	FITTING, 1/4FX1/4F ELBOW 90	2
▲▲ 24	200993	SPRAY BODY, 1/4" MALE	4
▲ 25	200996	●FILTER, SCREEN 100 MESH	4
▲ 26	200964	●FITTING, TIP 11003 T- JET	4
▲ 27	200994	●CAP, SPRAY BODY	4

▽ ASSEMBLY

▲ INCLUDED IN ASSEMBLY

● RECOMMENDED STOCK ITEMS

HAND TOOL, 5 in / 127 mm

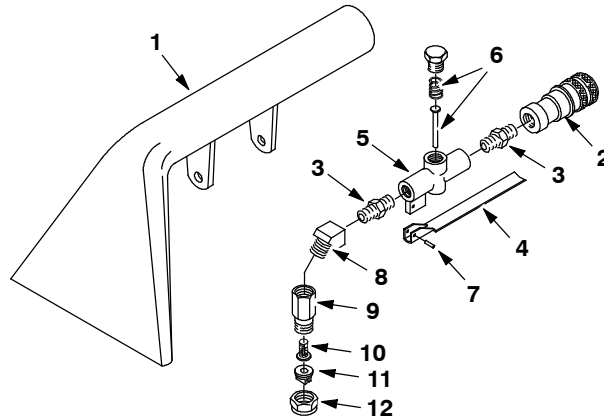

REF	PART #	DESCRIPTION	QTY.
▽	200505	●ASM., HAND TOOL 5" SERIES 60	1
▲ 1	200431.BK	TOOL, HAND BLACK	1
▲ 2	150913	FITTING, BRS QDC PF04 SER60	1
▲ 3	150606	FITTING, BRS STR PF04 HEX NIP	2
▲ 4	200905	LEVER, K- VALVE W/PIN	1
▲ 5	210210	●VALVE, FLOW CONTROL 04PF	1
▲ 6	190600	KIT, K- VALVE REPAIR	1

REF	PART #	DESCRIPTION	QTY.
▲ 7	140609	PIN, ROLL 0.187D X 0.56L	1
▲ 8	150403	FITTING, BRS E45 PF04/PF04	1
▲ 9	200992	FITTING, BRS STR PF02 SWIVEL	1
▲ 10	200996	FILTER, SCREEN 100MESH	1
▲ 11	200965	●FITTING, BRS TIP, 8002 T- JET	1
▲ 12	200994	CAP, NOZZLE SPRAY (8002)	1

HAND TOOL, CREVICE, 3 in / 76 mm

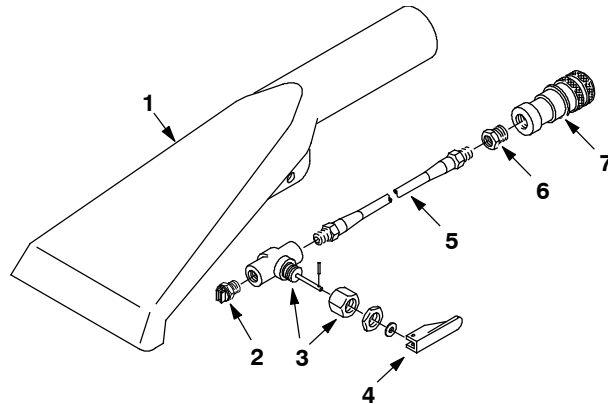

REF	PART #	DESCRIPTION	QTY.
▽	200517	●TOOL, CREVICE LP/HP SER 60	1
▲ 1	200436.BK	TOOL, CREVICE BLACK	1
▲ 2	200975	●FITTING, TIP #5002 1/8V- JET	1
▲ 3	210014	●VALVE, TOGGLE 02PF W/NUT	1

REF	PART #	DESCRIPTION	QTY.
▲ 4	210020	POSITIONER, VALVE HANDLE	1
▲ 5	160106	HOSE, SOLUTION CREVICE TOOL	1
▲ 6	150100	FITTING, BRS STR PF04/PF02	1
▲ 7	150913	FITTING, BRS QDC PF04 SER 60	1

▽ ASSEMBLY

▲ INCLUDED IN ASSEMBLY

● RECOMMENDED STOCK ITEMS

HAND TOOL, UPHOLSTERY, LOW PRESSURE

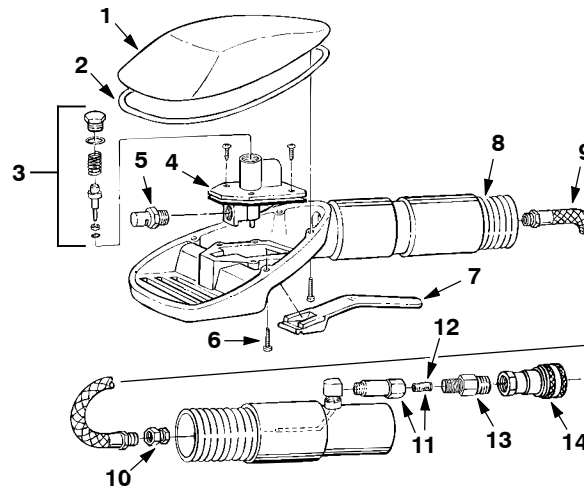

REF	PART #	DESCRIPTION	QTY.
▽	200540	●TOOL, UPHOLSTERY LP SER 60	1
▲ 1	200845	COVER, UPHOLSTERY TOOL	1
▲ 2	200843	GASKET, COVER	1
▲ 3	190631	●KIT, SERVICE LP UPHOLSTERY	1
▲ 4	210226	●VALVE, WATER/SOL 120VAC LP	1
▲ 5	200991	●FITTING, SS TIP 1/8K- JET	1
▲ 6	200838	SCREW, #06- 32 X 0.75	4
▲ 7	200840	TRIGGER, UPHOLSTERY TOOL	1

REF	PART #	DESCRIPTION	QTY.
▲ 8	200844	●HOSE, VAC UPHOLSTERY TOOL W/O CUFFS	1
▲ 9	200837	●HOSE, UPHOLSTERY TOOL	1
▲ 10	200848	FITTING, BRASS (3 PCS)	1
▲ 11	200842	FILTER, INLINE COMPLETE	1
▲ 12	200841	SCREEN ONLY, INLINE FILTER	1
▲ 13	150606	FITTING, BRS STR PF04 HEX NIP	1
▲ 14	150913	●FITTING , BRS QDC PF04 SER 60	1

▽ ASSEMBLY

▲ INCLUDED IN ASSEMBLY

● RECOMMENDED STOCK ITEMS