



FILTRONIC™ *Battery Powered*

HIGH SPEED BURNISHER

Owners Guide

OPERATION

SERVICE

CARE



CONTENTS:

- 2 *Safety Instructions*
- 3 *Battery Information*
- 4 *Control Panel Layout*
- 5 *Drive Controls / Operation*
- 6 *Maintenance*
- 8 *Hood Assembly*
- 9 *Shroud Assembly*
- 10 *Service / Adjustments*
- 11 *Lift Linkage*
- 12 *Deck ~~Lift~~ Mechanism*
- 13 *Chassis*
- 14 *Drive Assembly*
- 15 *Drive Control Assembly*
- 16 *Electrical Controls*
- 17 *Wiring Diagram (F22)*
- 18 *Wiring Diagram (F22T)*
- 19 *Trouble Shooting*
- 22 *Warranty*

MODELS: F22, F22T



INDUSTRIES, INC., 1351 W. Stanford Ave., Englewood CO 80110 USA *303-762-1800*FAX 303-762-0817



IMPORTANT SAFETY INSTRUCTIONS

When using battery powered machines, basic precautions should always be followed, including the following:

READ ALL INSTRUCTIONS BEFORE USING MACHINE

Operate from the rear of the machine only.

Use caution when operating the machine on a ramp or incline.
Do not turn the machine, or leave it unattended, on a ramp or incline.

Machine can cause an explosion when operated near flammable vapors or materials.

Store machine inside. Keep the electrical components of the machine dry.

Lead acid batteries have a number of inherent dangers, carefully read the instructions and warnings which accompany the batteries and battery charger.
REMEMBER: The batteries generate gasses which can ignite. Always charge in a well ventilated area. Keep sparks and flames away from the batteries. Do not smoke around the batteries. Avoid skin contact with the acid contained in the batteries. Always wear eye protection and protective clothing when working on or near batteries. Never allow metal objects to lay across battery tops.

All maintenance and repairs must be done by qualified personnel only.
Maintain adjustments on machine as specified in service manual.

Make sure all warning and caution labels are legible and properly attached to the machine.

SAVE THESE INSTRUCTIONS

Record the model and serial number on the blue data label located at the rear of the machine .

These numbers are used when calling upon the Windsor dealer for parts and service.

MODEL _____ SERIAL NO. _____ PURCHASE DATE _____

IMPORTANT SHIPPING NOTE

Carefully unpack your scrubber and inspect it for shipping damage. Any damages which occurred during shipping are the responsibility of the carrier, who must be notified immediately.

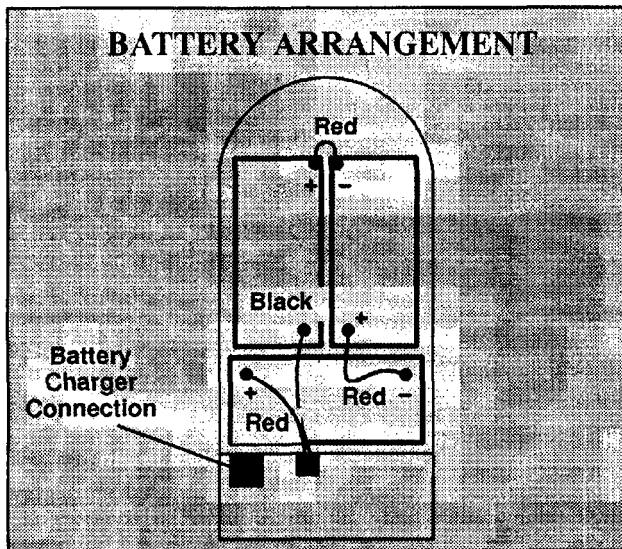

Battery Maintenance:

- 1.) When cleaning batteries use a solution of baking soda and water. (Do not allow cleaning fluid to enter inside battery cells.)
- 2.) Keep a proper electrolyte level in battery cells.
- 3.) Wipe down the battery tops at least once a week. If a cell should accidentally overflow, clean immediately.
- 4.) Test battery condition with a hydrometer at least once a week.
- 5.) Ensure that all connections are tight and that all corrosion is removed.
- 6.) Every 4 to 6 months remove batteries from the machine and clean the battery compartment.

Spare Parts and Accessories:

- 02100 Hydrometer
- 02101 Battery Post Cleaner
- 02143 Battery, 12V DC, 20 Amp, 185 Amp Hour
- 02104 Charger, 36V DC 20 Amp, Auto Shut-Off (115V)
- 02141 Charger, 36V DC 20 Amp, Auto Shut-Off (100V 50/60 Hz)
- 02142 Charger, 36V DC 20 Amp, Auto Shut-Off (230V 60 Hz)
- 02155 Charger, 36V DC 20 Amp, Auto Shut-Off (250V 50 Hz)
- 02163 Charger, 36V DC 20 Amp, Auto Shut-Off (230V 50 Hz)
- 23125 Cable, 12" Red
- 78231 Battery Tray

Battery Charging Procedure:

Charge the batteries once the amber charge level light comes on. The amber light indicates that there is about 20% charge left in the batteries. **Do not let the batteries completely drain before charging.** Avoid charging the batteries before the amber light comes on. The machine will run for hours on fully charged, well maintained batteries.

WARNING:

DO NOT SMOKE, HAVE OPEN FLAMES, OR SPARKS NEAR BATTERIES AT ANY TIME.

WEAR EYE PROTECTION AND PROTECTIVE CLOTHING WHEN WORKING WITH BATTERIES.

CHARGE BATTERIES IN A WELL VENTILATED AREA WITH DECK DOWN AND COVER OPEN.

- 1.) Use a 36 volt, 20 amp maximum output, D.C. charger which turns itself off, when the batteries are fully charged. The charger must have a connector that matches the machines battery connection.
- 2.) Read the instructions and warnings provided by the battery charger manufacturer.
- 3.) Set the charger in a well ventilated area on a level surface. Make sure cords will easily reach outlets on both machine and wall.
- 4.) Connect **charger to D.C. outlet on machine first.**
- 5.) Connect the A.C. power cord to properly grounded wall socket. **NEVER MAKE THE A.C. CONNECTION FIRST, HAZARDOUS SPARKS MAY RESULT.**
- 6.) After the batteries are completely charged disconnect the charger from the A.C. wall socket.
- 7.) Once the charger is disconnected from the A.C. wall socket it is safe to disconnect the charger from the machine.

8.) When the batteries are fully charged, check the electrolyte level by removing the caps on top of the batteries. If necessary fill the cells with distilled water as shown in the diagram to the right. Be careful not to overfill cells.

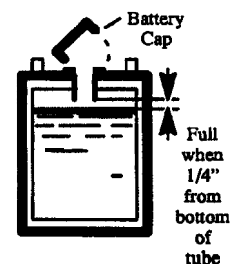

CONTROL PANEL

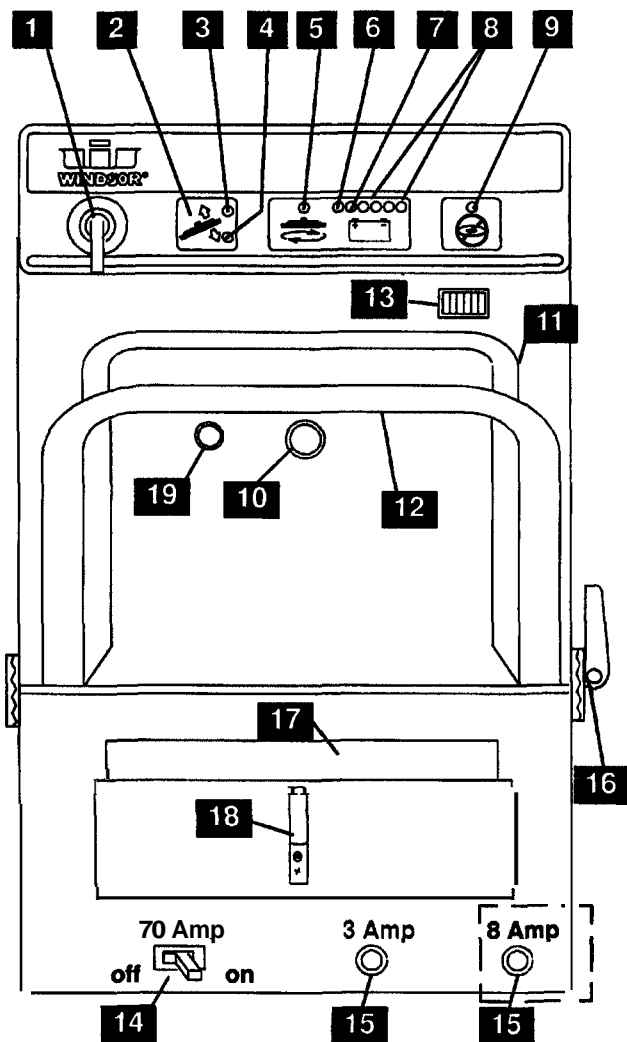

- 1.) Main power switch. Turns power on and off to machine.
- 2.) Deck lift switch. Tactile membrane switch raises or lowers deck when pressed.
- 3.) Deck raised, amber indicator light.
- 4.) Deck lowered, green indicator light.
- 5.) Polisher running, green indicator light. Light comes on when machine is running and the pad is making proper contact with floor.

- 6.) Battery charge drained, red light. Operator has less than ten minutes to return machine to charger. Once batteries are completely drained the red light flashes, polisher motor quits running, and the deck automatically raises.
- 7.) Battery charge level low, amber indicator light. Operator should return machine to charger.
- 8.) Battery charge level, green indicator lights. Each light represents 1/4 charge, lights go out as the batteries drain.
- 9.) Danger, no pad, red flashing light. If someone tries to operate the machine without the pad in place the deck will automatically raise and the machine will turn off. Turn main switch off and install pad. Machine can be turned back on once pad is properly installed.
- 10.) Brush wear, red indicator light. Worn carbon motor brushes need to be replaced before damage to motor occurs. (See page 16 Item 20)
- 11.) Pad driver bar, starts pad driver when squeezed to main handle, stops pad driver when released.
- 12.) Main handle.
- 13.) Hour meter.
- 14.) 70 amp magnetic circuit breaker, protects pad driver motor. To reset turn to "ON" position.
- 15.) 3 amp thermal circuit breaker, protects lift mechanism. Press to reset. 8 amp F22T

F22T DRIVE CONTROLS

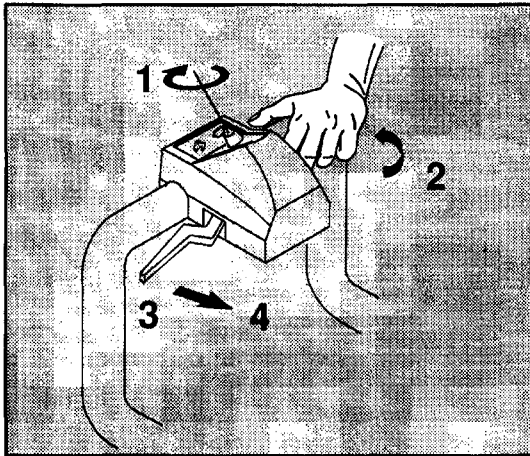

- 1.) The speed the machine will travel is regulated by the knob located on the controls which are found on the main handle. Turn the knob to the right to increase the speed of the machine.
- 2.) Squeezing one or both of the control levers will propel the machine forward at the selected speed.
- 3.) Releasing both control levers will stop the machine.
- 4.) Pressing forward on the levers moves the machine backwards at the selected speed.

Before starting the work period:

- 1.) Disconnect the battery charger. (See battery charging procedure)
- 2.) Close the cover.
- 3.) Raise the deck. (Turn on the main power switch and press the deck lift switch.)
- 4.) Turn or install a new buffing pad as needed.

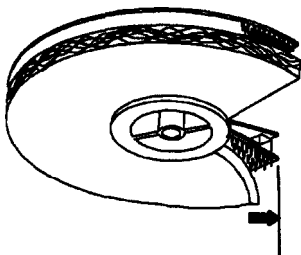

Ensure Pad is Centered on Pad Driver. Loosen Pad Lock and pull Pad to edge of Pad Driver in several directions.

- 5.) Check wheels and other pivot points for proper lubrication.

Operating the machine:

- 1.) If using a machine which was already set up, check to make sure the pad is properly installed.
- 2.) Adjust the operating control handle to a comfortable position using the handle lock lever.
- 3.) Turn on the main power switch.

- 4.) Lower or raise deck by pressing deck lift switch. On the F22 models a green light indicates position to begin polishing. Amber light indicates deck is fully raised
- 5.) All the machines, except for the F22T, are controlled by squeezing the thin pad driver bar and main handle together.

The F22T drive controls are shown above.

Caution: To prevent possible damage to the floor surface, always keep the machine moving while the pad is spinning.

The F22 pad pressure will adjust automatically to compensate for irregularities in the floor. pad thickness, aggressiveness, and load. The motor amp draw is monitored causing the front deck to be raised and lowered.

- 6.) When the drive handle is released the deck will automatically raise and the motor will turn off.
- 7.) The operator can continue polishing until all four green battery charge level indicator lights go out.
- 8.) Return the machine to the battery charger when the amber charge level light comes on.

**F22 MODELS
FILTER CARTRIDGE**

The filter (part no. 34212) is accessed using the latch at the front of the filter cover.

Periodically wash the filter out. **BE SURE THE FILTER HAS COMPLETELY DRIED BEFORE USING.**

FELT DUST CONTROL SKIRT

Replace skirt (part no. 73520) when excessively soiled, worn, torn, or damaged in any way that allows dust to escape.

Located inside the shroud the dust control skirt is easily replaced. Each slot on the skirt slips onto a tee nut inside the shroud.

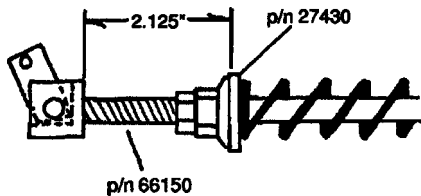

ACTUATOR SPRING

To ensure pad pressure consistency, the distance between the bottom of the cap spring (p/n 27430) and the flange on the actuator pivot (p/n 66150) should be 2.125" (see above).

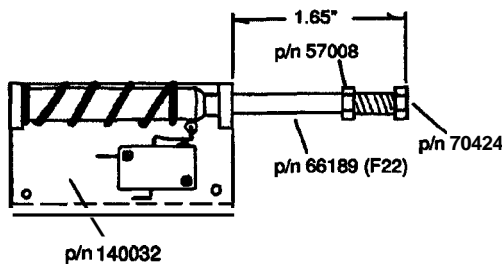

LIFT LINKAGE

To ensure that the pad is at the proper height when in the "ready" position, the distance between the edge of the safety switch bracket (p/n 140032) and the end of the plunger assembly (see above) must be 1.65".

Weekly Maintenance:

- 1.) Use a hydrometer to check the condition of each battery cell.
- 2.) Check battery cable clamps. Ensure clamps are tight on battery terminals.
- 3.) Clean tops of batteries with a wet cloth and a solution of water and baking soda. Wipe battery tops dry after cleaning.
- 4.) Check pad lock for looseness or damage.
- 5.) Check filter and filter seals. Air flow should be unobstructed through filter.
- 6.) Ensure that the chain, on the F22T model, and the pivot points and casters, on all models, are properly lubricated.
- 7.) Tighten any loose screws or nuts.

At the end of each work period:

- 1.) Wipe down the exterior of the machine.
- 2.) Vacuum out the filter cartridge.
- 3.) Lower the deck.
- 4.) Open the cover.
- 5.) Charge the batteries.
(See battery charging procedure on page 3).





4 to 6 Month Maintenance:

- 1.) Remove batteries = clean battery tray and battery compartment.
- 2.) Clean battery cable clamps and battery terminals.
- 3.) Check the drive chain tension on the F22T. Tighten, clean and lubricate if necessary.
- 4.) Check the carbon motor brushes in the pad driver motor.
(#17 on page 12)
- 5.) Use a vacuum to remove lint or dust build-up from motor windings.

L22AF (OBS)

Lubrication:

The following symbols found throughout the manual indicate items requiring lubrication:

-  Apply grease
-  Use spray lubricant.
-  Use anti-seize when repairing.
-  Permanent (Red) Thread Lock

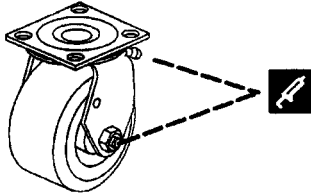

CAUTION: Do not use pressure washers to clean sealed gearboxes or bearings.

If it becomes necessary to clean under machine with a pressure washer, ensure all items noted are re-lubricated.

Suggested Spare Parts List

Breaker 3 Amp	4717
Breaker, Circuit 70 Amp	14917
Caster, 4" Polyurethane Swivel	18027
Cable Asm., Battery Jumper x 15	23125
Cable Asm., 4Ga red x 27"	23126
Cable Asm., 4Ga blk x 37"	23127
Filter, Cartridge Dust Control	34212
Gasket, FILTRONIC Filter	35117
Gasket, Pol Filter	35131
Holder, Centerlock	41161
Circuit Board, Control	27035
Pad Driver	66182
Relay, 36VDC 100A	67166
Switch, Main Rotary	72051
Switch, 125VDC SP NC roller	72053
Switch, Contact Block Clip	72088
Switch, Contact Module Nr	72089
Switch, 125VDC SPST N.O.	72092
Skirt, Shroud Felt	73520
Wheel, Squeeeee Bumper	89059

NOTES:

HOOD ASSEMBLY F22, F22T

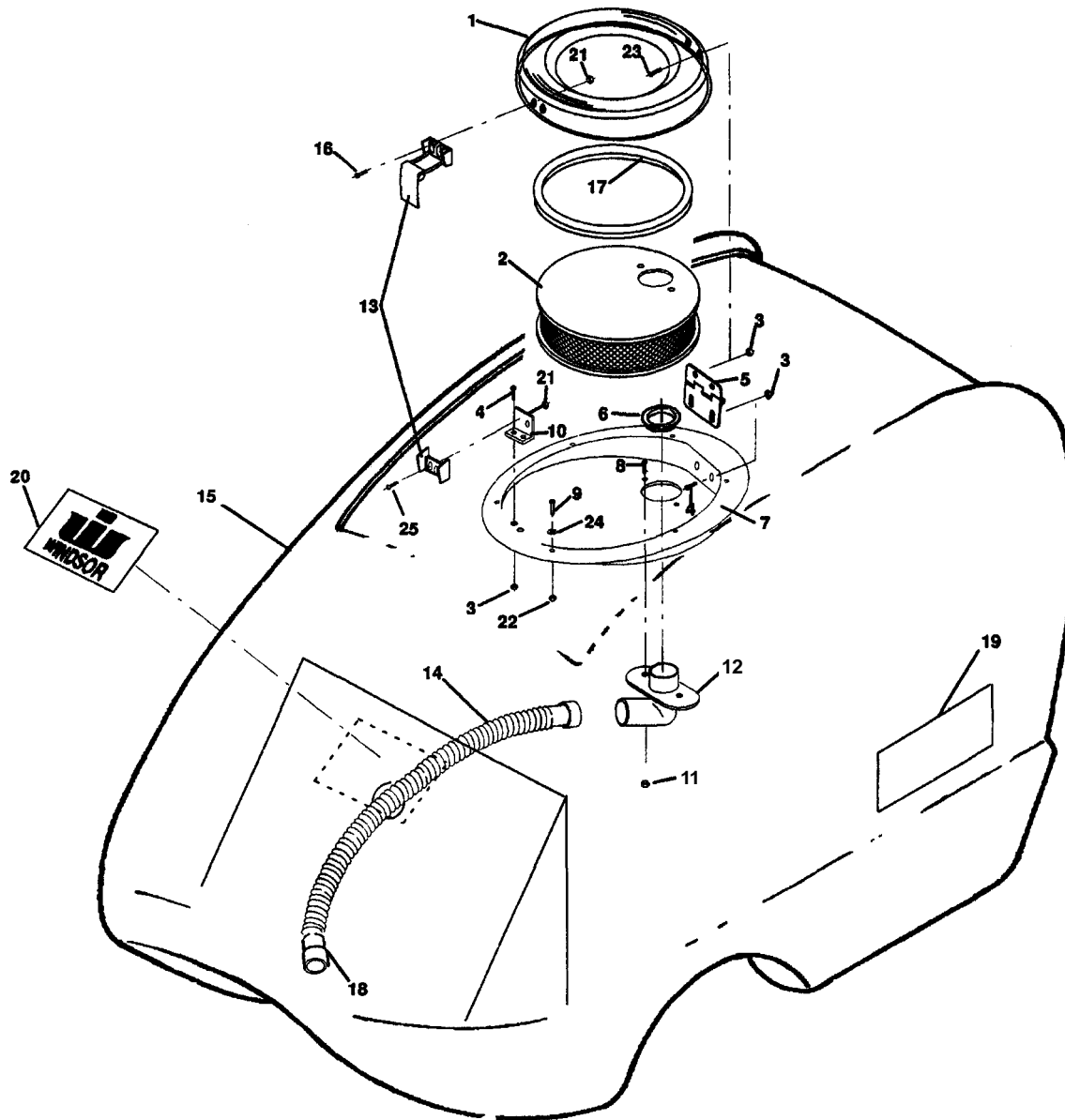

PARTS LIST:

KEY	PART NO.	DESCRIPTION	KEY	PART NO.	DESCRIPTION
1	27543	Cover, F22 Filter	13	51179	Latch, Filtronic Filter Cover
2	34212	Filter, Cartridge Dust Control	14	39246	Hose, 1.5 Blue Vac x 26"
3	57104	Nut, 10-32 w/ Star Washer	15	27544	Cover, F22 Main Trim
4	70088	Screw, 10-32 x 1/2 PHMS	16	70052	Screw, 8-32 x 3/8 PHMS
5	41233	Hinge, F22 Filter Cover	17	35131	Gasket, Polisher Filter
6	35117	Gasket, Filtronic Filter	18	27354	Cuff, Blue S/C Vac Hose
7	62374	Plate, Dust Control Filter	19	50569	Label, F22 Main
8	70177	Screw, 10-32 x 1/2 FHMS SS	20	50617	Label, "Windsor" logo
9	70066	Screw, 10-32 x 3/4 PHMS	21	57106	Nut, 8-32 w/ Star Washer pltd
10	14860	Bracket, F22 Latch	22	57030	Nut, 10-32 Nyl Self Lock Plt
11	57008	Nut, 8-32 w/ Hex	23	70162	Screw, 10-32 x 3/8 PHMS
12	31063	Elbow, Assembly F22 Dust Ctrl	24	87018	Washer, #10 x 9/16 OD
			25	70051	Screw, 8-32 x 1/2 PPHMS

SHROUD ASSEMBLY

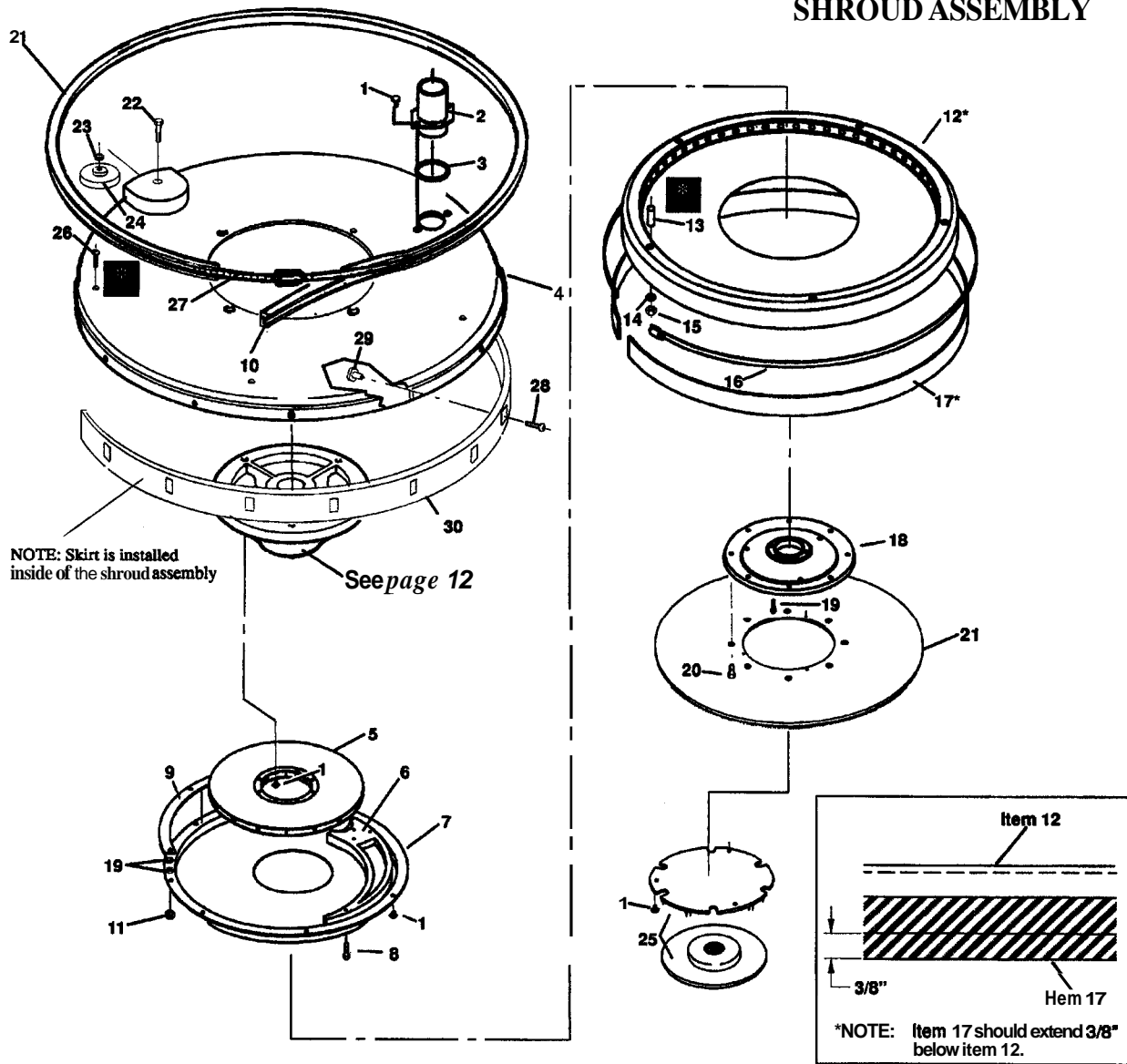

PARTS LIST:

KEY	PART NO.	DESCRIPTION	KEY	PART NO.	DESCRIPTION
1	70351	Screw, 10-32 x 3/8 HHTR	16	20076	Clamp, Worm Gear .5WX24 #390
2	78266	Tube Assembly, F22 Dust	17	73536	Seal, Intermediate Shroud
3	35117	Gasket, Filtronic Filter	18	41187	Hub, Flex Disc
4	73593	Shroud Assembly, Brush F22/22T	19	70383	Screw, 10-32 x 3/4 PHTR
5	14667	Blower Assembly, L2000D	20	70384	Screw, 1/4 -20 x 1/2 PHTR
6	14742	Block, Impeller Housing	21	66182	Pad Driver, F22
7	41188	Housing, Impeller	22	70368	Screw, 3/8-16 x 1.75 HHMS
8	70198	Scr, #10 x 3/4 PHSM	23	87003	Washer, 3/8 ID x 7/8 OD
9	36130	Gasket, Impeller Housing	24	89059	Wheel, Bumper
10	14740	Bumper, Shroud	25	41161	Pad Holder, Center Lock gry
11	57104	Nut, 10-32 w/ Star Washer	26	70433	Screw, 10-32 x 1.5 PHMS Blk Zinc
12	73519	Shroud, Intermediate	27	20046	Clamp, 2.25" Wormgear
13	73615	Spacer, .375 x .194 x 1.06	28	70052	Screw, 8-32 x 3/8 PPHMS
14	87018	Washer, #10 x 9/16 OD	29	57177	Nut, Tee 8-32 x 7/16 L2020D, F22
15	57017	Nut, 15/32-32 Panel	30	73520	Felt Skirt, F22

ACTUATOR REMOVAL

- 1.) Switch **on** main switch and lower buffering head to floor. Switch **off** main switch.
- 2.) Remove main cover and batteries.
- 3.) Lay machine **on** left side.
- 4.) Remove actuator connecting **lift** link #42 on page 11.
- 5.) Disconnect motor **leads**.
- 6.) Remove (4) bolts holding actuator bracket to frame and **lift** out actuator.

Testing Actuator Barrel Travel:

- 1.) Do not allow the barrel to rotate the 1/2"-9/16" (1,25 to 1,4 cm) adjustment will be lost).
- 2.) Connect white wire to the (+) positive post and the black wire to the (-) negative post of the 36VDC power supply to retract **the** barrel to the lower limit.
- 3.) Black wire to the (+) positive post and the white wire to the (-) negative post of the 36VDC power supply to extend the barrel to the upper limit.
- 4.) Reverse the wires to retract the barrel electrically. the actuator is now ready for assembly and installation.

LIMIT SWITCH SETTINGS

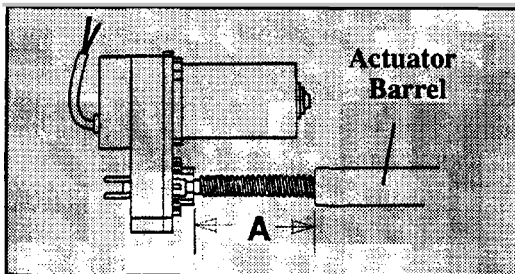

Lower Adjustment

- 1.) Connect the white wire to the (-)negative post of a 36VDC power supply and the black wire to the (+) positive post. **This** will retract or close the actuator barrel. Maintain the connection **until** the limit switch shuts **the** power off.
- 2.) Disconnect both wires **from** the power supply. Set "A" (barrel to frame gap) at between 1/2 and 9/16 of an inch (1,25 to 1,4 cm) rotating by hand.

Upper Adjustment

1.) Hold Barrel With Hand

Reverse the wire connections to the 36VDC power supply, white wire to the (+) positive post and the black wire to the (-) negative post. **This** will extend or open the actuator barrel.

Do not allow barrel to rotate.

- 2.) Extend actuator barrel electrically **until** it stops. Ensure "A" is between 3 3/4 and 3 7/8 inches (9,5 to 9,9 **cm**) on all models.
- 3.) If the dimension is incorrect, disconnect from the power supply and set the switch cam adjustment.

Switch Cam Adjustment

- 1.) Remove the two cam switch cover screws (TORX T15) and remove cam **switch** cover.
- 2.) Loosen the two cam lock screws (TORX T20) on the cams.

CAUTION:

Do not allow retract cam to rotate.

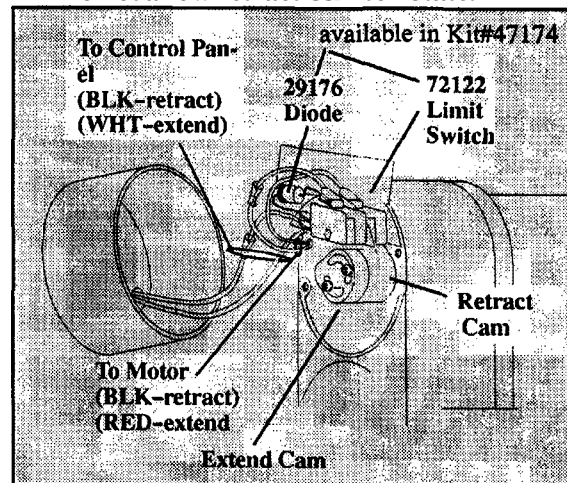

- 3.) If the "A" dimension is incorrect, turning the cam clockwise will INCREASE "A", counter-clockwise will DECREASE "A".
- 4.) Tighten the two cam lock screws and cycle the actuator. **Do Not Allow The Barrel To Rotate.** Check the extended "A" dimension. If it is correct, **replace** the cover with screws. If not repeat 3 above.

LIFT LINKAGE

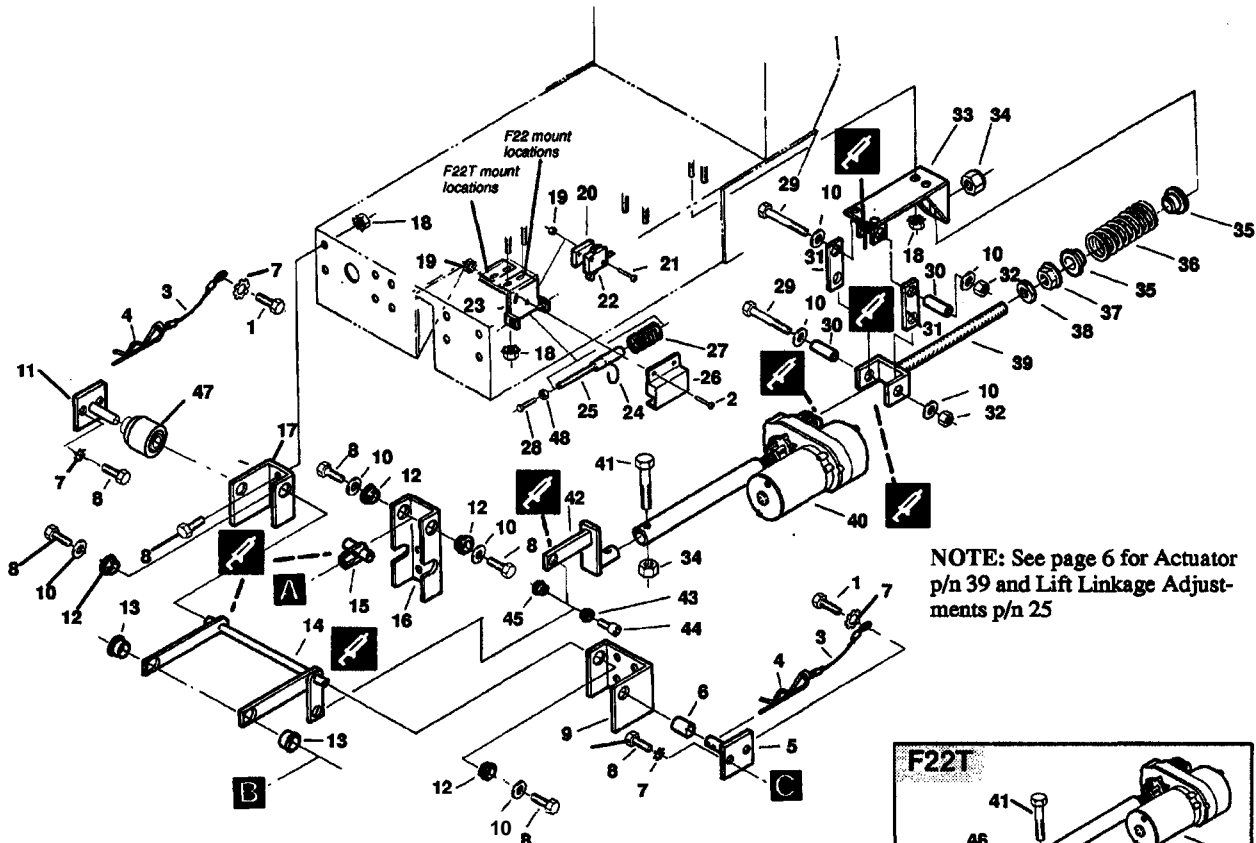

NOTE: See page 6 for Actuator p/n 39 and Lift Linkage Adjustments p/n 25

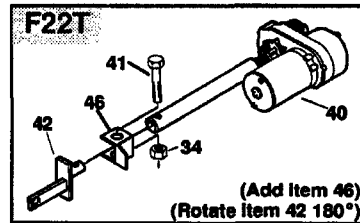

NOTE:
When the actuator continues running beyond the set limits use page 10 to adjust or replace switches.

KEY	PART NO.	DESCRIPTION	KEY	PART NO.	DESCRIPTION
1	70015	Screw, 1/4-20 x 3/16 HHMS	25	66189	Plunger, Safety Switch F22's
2	70242	Screw, 4-40 x 1/4 PHMS	26	23635	Cover, Ext. Micro Switch Brkt F22(T
3	27457	Cord Assembly, Cover Pin	27	73706	Spring, Compression F22 (Blk)
4	66092	Pin, Hair Spring Cotter	29	70424	Screw, 9/32 x 5/8 HHMS Pltd
5	66149	Pivot, Cover	29	70105	Screw, 1/4-20 x 1.75 HHMS
6	14725	Bushing, Cover Pivot	30	14714	Bushing, 1/4 x 3/8 x 1-1/4L
7	87025	Washer, 114 Star	31	51152	Link, Actuator Pivot
8	70020	Screw, 1/4-20 x 1/2 HHMS	32	57047	Nut, 1/4-20 Nylock
9	14704	Bracket, Deck Linkage (Left)	33	54134	Mount, Actuator Spring
10	87013	Washer, 114 ID x 5/8 OD Flat	34	57022	Nut, 3/8-16 Nylock
11	66201	Pivot Asm, F22T	35	27430	Cap, Spring
12	14708	Bushing, Flange 1/2 x 3/4 OD	36	73443	Spring, 3" 240 Lb/in Comp. Blck.
13	14593	Bushing, Deck Linkage	37	57032	Nut, 3/8-16 Flange
14	51147	Linkage, Deck Lift	38	57085	Nut, 3/8-16 Hex Jam
15	51151	Linkage, Deck Guide Adj (F)	39	66150	Pivot, Actuator Spring
16	14705	Bracket, Deck Linkage (Mid)	40	05051	Actuator, 36V DC 4" Stroke
17	14706	Bracket, Scrub Deck Linkage (R)	41	70070	Screw, 3/8-16 x 2 HHCS
18	57105	Nut, 1/4-20 Hex w/ Star washer	42	51153	Linkage, Actuator Connecting
19	57163	Nut, 4-40 Hex w/ Star washer	43	14491	Bushing, .25 X 3/8 SHCS
20	73456	Spacer, Plunger Switch	44	70346	Screw, 1/4-20 x 3/8 SHCS
21	70245	Screw, 4-40 x 3/16 PHMS	45	14580	Bushing, 1/4-20 X .28 Flange
22	72053	Switch, 125VDC SPST NC	46	62460	Plate, Micro Switch Plunger F22T
23	140032	Bracket, Ext. Microswitch Mntg. (Both)	47	140061	Bushing / Collar Assembly
24	67286	Snap Ring, 5/16	48	57008	Nut, 8-32 Hex Pltd

DECK LIFT MECHANISM

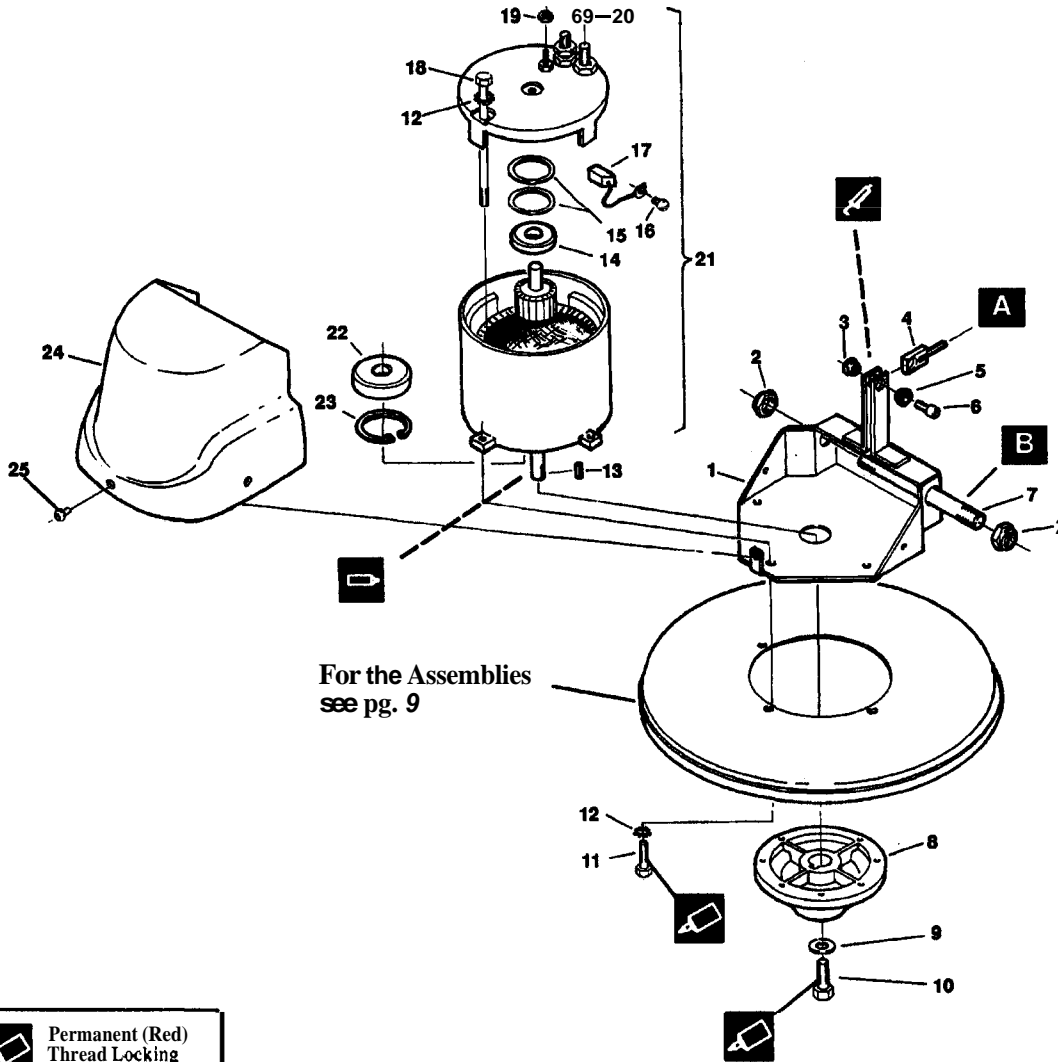

 Permanent (Red) Thread Locking adhesive

PARTS LIST:

KEY	PART NO.	DESCRIPTION	KEY	PART NO.	DESCRIPTION
1	54130	Mount, Scrub Deck	13	48045	Key, 3/16 SQ x 1/2 L
2	57153	Nut, 1/2-13 Ny-Lock (Thin)	14	09051	Bearing, Upper Motor
3	14580	Bushing, Threaded (1/4-20)	15	87106	Washer, Bearing Thrust
4	51149	Linkage, Deck Guide Adj (M)	16	70344	Screw, 10-32 x 1/2 PHMS Brass
5	14491	Bushing, Socket	17	14728	Brush Set, 2000rpm
6	70346	Screw, 1/4-20 x 3/8 SHCS	18	70408	Screw, 1/4-20 x 7-1/2 HHCS
7	67238	Rod, Deck Lift	19	57168	Nut, 10-32 Hex Brass
8	41201	Hub, pad Driver	20	57125	Nut, 5/16-18 Hex Brass
9	87102	Washer, 5/16 x 1-1/4 OD Flat	21	53190	Motor, 2-1/2 hp 36VDC 2000rpm
10	70244	Screw, 5/16-24 x 1/2 HHMS	22	09052	Bearing, Lower Motor
11	70015	Screw, 1/4-20 x 3/4 HHMS	23	67142	Snap Ring
12	87025	Washer, 1/4 Star	24	27427	Cover, Motor
			25	70351	Screw, 10-32 x 3/8 HHTF w/ Star

CHASSIS

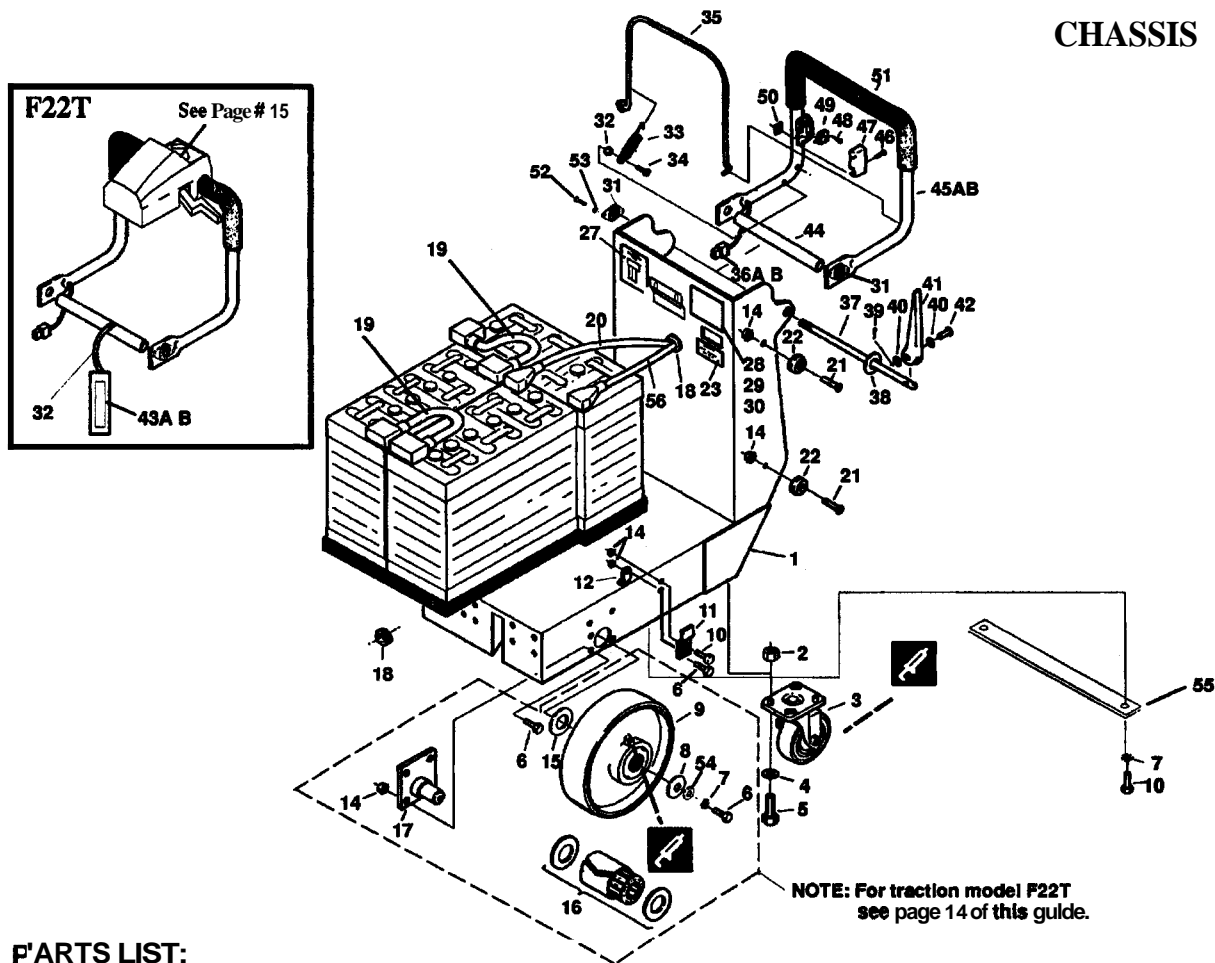

PARTS LIST:

KEY	PART NO.	DESCRIPTION	KEY	PART NO.	DESCRIPTION
1	34235	Frame Asm, L2020/F22	33	73450	Spring, Safety Switch
2	57119	Nut, 3/8-16 Lock	34	70383	Screw, 10-32 x 3/4 PHTR
3	18027	Caster, 4" Swivel	35	38173	Handle, Safety Switch
4	87003	Washer, 3/8 ID x 7/8 OD	36A	76004	Connector, 2 Pin Molex
5	70266	Screw, 3/8-16 x 1.0 HHCS Gr 5	36B	76015	Terminal, Female Pin Molex
6	70015	Screw, 1/4-20 x 3/4 HHMS	37	67233	Rod, Handle Adjustment
7	87025	Washer, 1/4 Star	38	87080	Washer, .5 x 1.25 Flat Gr 8
8	87122	Washer, L2020 Wheel Lock	39	66073	Pin, 1/16 x 3/4 Cotter
9	89070	Wheel, 10" F22 only	40	87018	Washer, #10 x 9/16 OD
10	70020	Screw, 1/4-20 x 1/2 HHCS	41	51142	Lever, Handle Lock
11	14730	Bracket, Battery Retainer	42	66133	Pin, 3/16 x 7/8 Clevis
12	20015	Clamp, 9/16 Dia. Nylon	43A	50514	Card, L2020B Instructions
14	57105	Nut, 1/4-20 w/ Star Washer	43B	50530	Card, "Made in U.S.A."
15	87116	Washer, 1.14 x 2.50 x .084	44	78269	Tube, Handle Adjustment
16	09050	Bearing, Wheel	45A	38206	Handle Asm, L2020 New style
17	03062	Axle, F22 only	45B	38195	Handle, F22 Propel
18	36020	Grommet, 5/8 ID x 1.12 OD	45C	38171	Handle Asm, L2020 Old style
19	23125	Cable, 4 GA RED x 12"	46	70309	Screw, 6-32 x 1/4 HHTC -F-
20	23127	Cable, 4 GA BLK x 27"	47	27438	Cover, Switch
21	70166	Screw, 1/4-20 x 1/2 FHMS	48	70407	Scr, #4-40 x 1/2 PHMS
22	73454	Spacer, Main Cover	49	72093	Switch, 125VDC SPST N.O.
23	50413	Label, Charger Warning	50	57167	Nut Plate, Switch Mount
27	50497	Label, Battery Warning	51	36059	Grip, Handle
28	50606	Label, Wiring Diagram	52	70228	Screw, 3/8-16 x 1.5 HHMS
29	50492	Label, L2020B Wiring Diagram	53	87095	Washer, #10 Flat
30	50590	Label, F22 Wiring Diagram	54	87013	Washer, 1/4 ID x 5/8 OD
31	51184	Lock, Handle Adjustment	55	14731	Brace, L2020B Frame
32	27417	Cord, 99087 1/8 x 12"	56	23126	Cable Asm, 4 Ga. Red x 27"

DRIVE ASSEMBLY

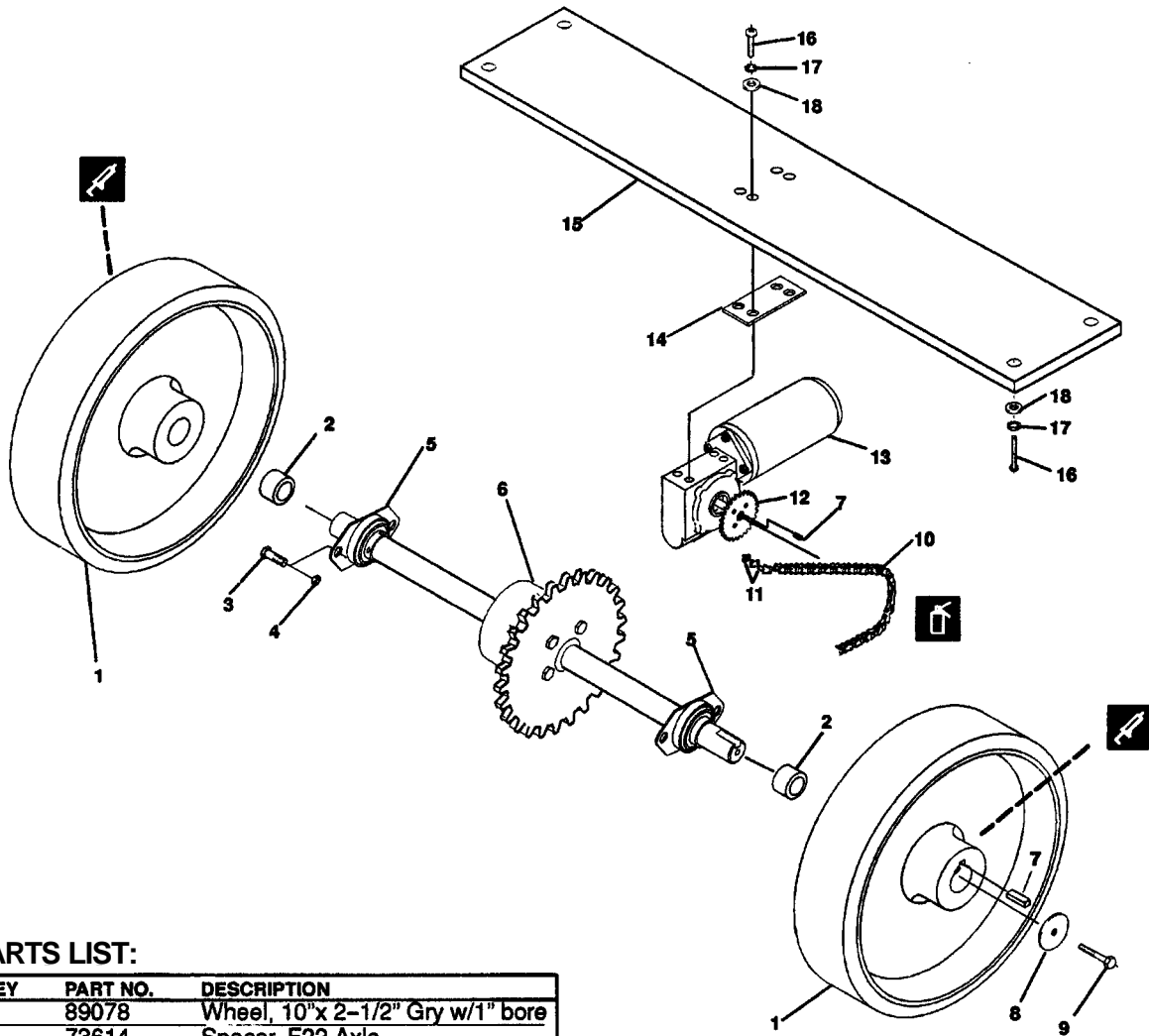

PARTS LIST:

KEY	PART NO.	DESCRIPTION
1	89078	Wheel, 10"x 2-1/2" Gry w/1" bore
2	73614	Spacer, F22 Axle
3	70266	Screw, 3/8-16 x 1.0 HHCS Gr5 .
4	57032	Nut, 3/8-16 Serrated Flg
5	09066	Bearing Asm, F22T
6	29170	Differential, F22P
7	73605	Key, 1/4 x 1/4 x 2-1/2
8	87008	Washer, 1/4 ID x 1-1/4 OD
9	70020	Screw, 1/4-20 x 1/2 HHCS
10	27553	Chain, #40, 1/2" Pitch x 40
11	27343	Chain, Master Link, #40, 1/2
12	73565	Sprocket, #40B11 F 1/2
13	53208	Motor, 36VDC Gear
14	62389	Plate, Motor Spacer
15	62388	Plate, Propel Motor
16	70015	Screw, 1/4-20 x 3/4 HHCS
17	87025	Washer, 1/4 Lock Ext Star SS
18	87013	Washer, 1/4 ID x 7/8 OD SS

F22T DRIVE CONTROL ASSEMBLY

Adjustment of potentiometers for drive control

1. Turn the speed potentiometer (U) fully clockwise. (Max. speed)
2. Loosen the set screw (#21) and adjust the direction potentiometer (T) to center of travel.
3. Turn the main power switch on.
4. If the machine moves, adjust the direction potentiometer until movement stops.
5. Tighten the set screw (#21)

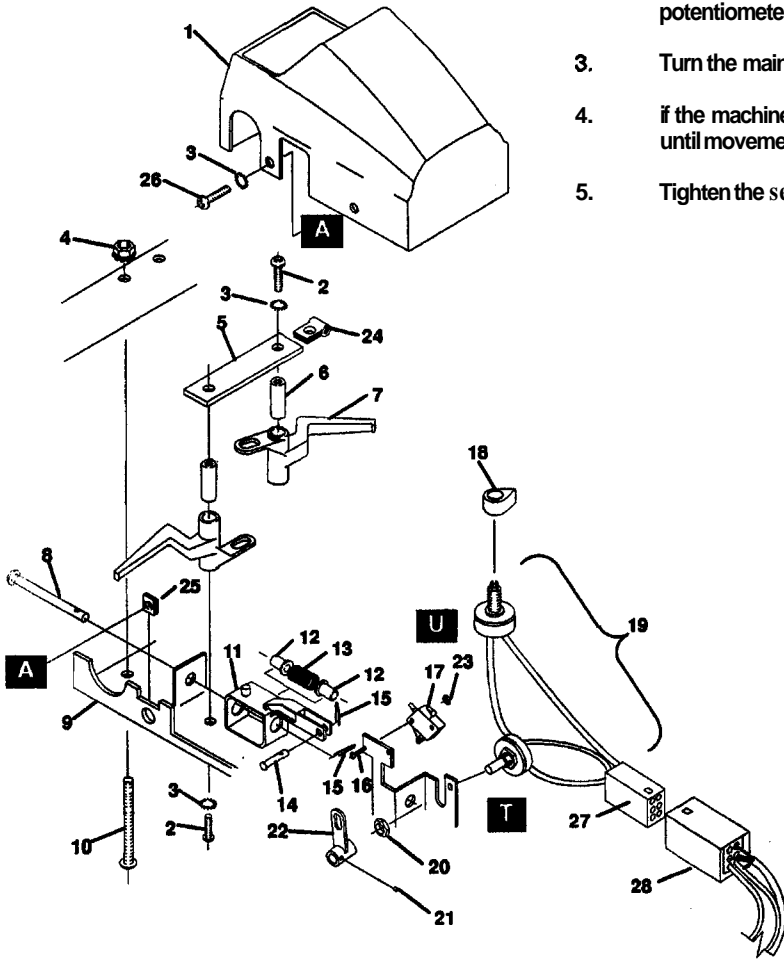

PARTS LIST:

KEY	PART NO.	DESCRIPTION	KEY	PART NO.	DESCRIPTION
1	27568	Cover, F22P Propel	15	66073	Pin, 1/16 x 3/4 Cotter
2	70162	Screw, 10-32 x 3/8 PHMS SS	16	70245	Screw, 4-40 x 3/4 PHMS Pltd
3	87016	Washer, #10 Lock Ext. Star	17	72093	Switch, 125VDC SPST N.O.
4	57104	Nut, 10-32 w/ Star Washer	18	48043	Knob, PT26/32 Speed Control
5	71116	Support, Lever Pivot	19	88692	Wire Asm, F22P Pot. w/o Conn.
6	67271	Rod, Handle Lever Pivot	20	57024	Nut, 3/8-27 Panel
7	51186	Lever, Propel Control Handle	21	70084	Set Screw, 8-32 x 3/16 KCP
8	66184	Pin, Clevis 1/4 x 2.438	22	66183	Pivot, Potentiometer
9	62379	Plate Assembly, Propel Control	23	57163	Nut, 4-40 w/ Star Washer
10	70092	Screw, 10-32 x 1.5 PHMS	24	20005	Clamp, 5/16 dia. nylon
11	36136	Guide, Lever Centering	25	57028	Nut, 10-24 Tinnerman
12	14866	Bushing, Propel Control	26	70406	Screw, #10B x 3/8 PHSM Blk
13	73236	Spring, 1.12" Lg Compression	27	27554	Connector, 6 pin recept. Molex
14	66191	Pin, Clevis 3/16 x 1/2	28	88696	Wire Asm, F22P Control

ELECTRICAL CONTROLS

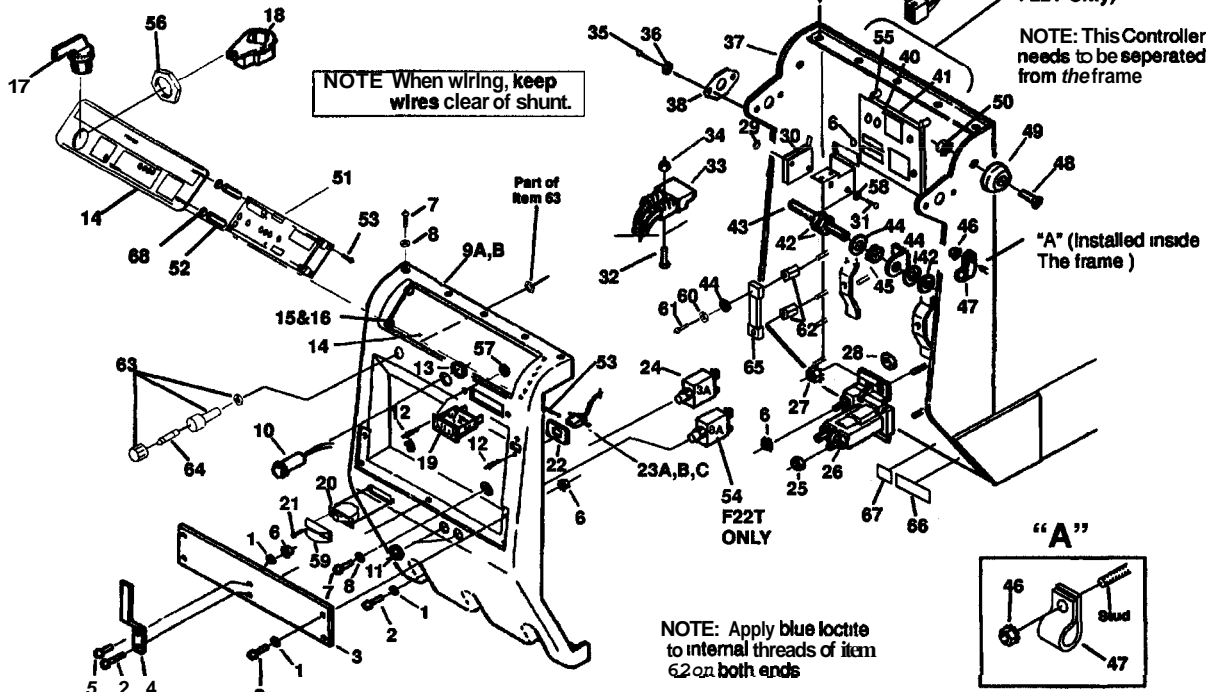

PARTS LIST:

KEY	PART NO.	DESCRIPTION	KEY	PART NO.	DESCRIPTION
1	87018	Washer, #10 x 9/16 OD	33	76067	Connector, 50 Amp DCA Gry
2	70066	Screw, 10-32 x 3/4 PHMS	34	57102	Nut, Strain Relief, M18,6
3	27434	Cover, Storage	35	70228	Screw, 10-32 x 1/4 PHMS SS
4	41144	Hook, Cord	36	87095	Washer, #10 Flat
5	70088	Screw, 10-32 x 1/2 PHMS	37	34235	Frame Asm, L2020/F22
6	57104	Nut, 10-32 w/ Star Washer	38	51184	Lock, Handle Adjustment
7	70406	Screw, #10B x 3/8 PHSM (Blk)	39	22073	Connector, 6 Pin, 22 polarizing
8	87117	Washer, #10 Flat (Blk)	40	27579	Controller, 36VDC 1.8sec delay
9A	27571	Cover, Rear F22	41	34227	Foam, F22T Circuit Board
9B	27572	Cover, Rear F22T	42	57125	Nut, 5/16-18 Brass
10	51154	Light, Brush Wear Indicator	43	70289	Stud, 5/16-18 x 2.12
11	57024	Nut, 3/8-27 Panel	44	87092	Washer, 5/16-ID x 3/4 Brass
12	67240	Rivet, 1/8 x 1/2 Aluminum (Blk)	45	36019	Grommet, 5/16 ID x 9/16 grv OD
13	87101	Washer, 1/2 ID Spring	46	57116	Nut, 6-32 w/ Star Washer PLTD
14	62352	Plate, Switch Panel	47	20015	Clamp, 9/16 Dia. nylon
15	70394	Screw, 6-32 x 1/2 THMS (Blk)	48	70201	Screw, 1/4-20 x 3/4 PHMS
16	57157	Nut, 6-32 U-Tinnerman	49	73454	Spacer, Main Cover
17	72051	Switch, Main Rotary	50	57105	Nut, 1/4-20 w/ Star Washer
18	72050	Switch, Rotary Block	51	27635	Circuit Board, Control
19	54092	Meter, DC 0-60 VDC Hour	52	73538	Standoff, 5/8x6-32 Int Thread
20	14917	Breaker, 70 Amp DC	53	70134	Scr, 6/32 x 5/8 SS
21	70127	Screw, 6-32 x 1/4 PHMS	54	14668	Breaker, Circuit 8A
22	62314	Plate, Molex Mounting	55	73734	Spacer, 3/8 OD x 1/4, L. Alum.
23A	88696	Wire Asm, F22P	56	57107	Nut, M22.5
23B	27554	Connector, 6-pin Molex	57	87068	Washer, 1/8 Rivet Backup
23C	76015	Pin, Female	58	87082	Washer, #4 Ext Star
24	14717	Breaker, 3 Amp Circuit	59	36160	Guard, Circuit Breaker
25	57117	Nut, 5/16-24 Hex	60	87151	Washer, 1/4 Split Lock Blk
26	67166	Relay, 36VDC 100Amp	61	70015	Screw, 1/4-20 x 3/4 HHMS
27	57105	Nut, 1/4-20 w/ Star Washer	62	73659	Standoff, Insulator
28	36125	Grommet, 3/4 ID x 1.38 OD	63	34160	Fuseholder, 15A, 250V
29	57163	Nut, 4-40 w/ Star Washer	64	34259	Fuse, 3A, Fast-Acting
30	72124	Switch, F22 Battery Safety	65	73707	Shunt, Type A DC Ammeter 100V
31	70245	Screw, 4-40 x 3/4	66	50494	Label, Machine Data
32	70239	Screw, 6-32 x 3/4 PHMS	67	50689	Label, Patent License
			68	87017	Washer, # 8 Flat

Troubleshooting Chart

Condition	Corrective Action
No Power To Machine:	
Poor Cable Connection	Clean battery cable clamps of any corrosion and tighten test voltage at points A to B should be from 34 to 38 VDC.
Faulty micro switch	Test voltage at points C to B should be from 34 to 38 VDC. If there is no voltage check switch for continuity. Adjust or replace as needed
Faulty main power switch	With the main power switch turned on, test voltage at points B to D should be from 34 to 38 VDC. If there is no voltage remove leads and check switch for continuity. Replace if necessary
Faulty control board	Test voltage at L6 to K7 should be from 34 to 38 VDC. If the voltage is good at L6 to K7 but the machine still won't respond, all the tests above have been done, replace the control board.
Blown fuse	Replace fuse
Pad motor won't run	
Circuit breaker has tripped	Reset circuit breaker. (N)
Faulty drive handle switch	Unplug connector coming from main handle assembly. Squeeze handle and test for continuity at handle end of connector E. Adjust or replace switch as needed . See page 13 & 15 for exploded view of switch cover (F22) and drive control assemblies F22T,
Faulty relay	With main power on, pad in operating position and drive handle squeezed: Test voltage at points F to G and F to B should be from 34 to 38 VDC. When the relay is working it should make a clicking noise as the drive handle is squeezed. Replace relay if the test voltage s measure properly and the pad motor still does not run. If the test voltages are not 34 to 38V DC, check wiring and connections at points F, G , D and B.
Brush wear light on	
Carbon motor brushes need to be replaced	When the brush wear indicator light comes on it is necessary to put a new set of carbon motor brushes in. <i>Caution:</i> Continuing to run the machine until the brushes wear away completely will cause motor damage.
Deck lift mechanism not working	
Circuit breaker has tripped	Reset circuit breaker (M)
Loose actuator connections	Check connections J1 & J2 and K3 & K4 on control board along with all other connections to actuator.
Faulty actuator circuit breaker or actuator	With the main power switch turned on and the pad up/down switch depressed, test voltage at K4 to K3 should be from 34 to 38 VDC. If the voltage is good at K4 to K3 but the actuator still is not operating it will need to be repaired or replaced.
Faulty control panel	Unplug the connector at J on the control board. Test J (coming from control panel) for continuity when pad switch is pressed. Replace control panel if necessary .
Faulty control board	Test voltage at L6 to K7 should be from 34 to 38 VDC. If the voltage is good at L6 to K7 but the lift mechanism still won't respond, all the tests above have been done, replace the control board.
Deck stays on floor after motor after motor stops	Check for worn out pad.
Deck height fluctuates excessively	Check for worn out pad.

Troubleshooting Chart (cont.)

Condition	Corrective Action
<p><u>Control panel completely lit machine not responding</u> Control board stuck in the self check mode</p>	<p>When the main power is turned on within 3 seconds of the time that the battery charger plug is removed the control board initiates a self diagnostic program. To cancel the self diagnostic program check, simply turn off the main power switch for 3 seconds and turn it back on. If the problem persists, turn off the main switch and remove the 3 amp fuse for 5 seconds. Replace the fuse and turn on the main switch.</p>
<p><u>Drive Controls (F22T)</u></p>	
Circuit Breaker tripped	Reset circuit breaker (W).
Loose connections	Check all connections in propel motor circuit especially at P, Q, R, V and X.
Faulty micro switch	With the batteries disconnected, disconnect the wire leads to the micro switch, at V, and test for continuity. When the control levers are squeezed the micro switch is engaged. There should be a slight clicking sound when the switch is engaged. Adjust or replace as necessary.
Faulty potentiometer	With the drive motor disconnected at Q or X test the output voltage to the drive motor. The output voltage at Q or X should vary from 0 to 24 volts as the potentiometer U on the controls is adjusted and the control levers are squeezed. Resistance of the potentiometers can be tested at the green and black leads found at the mox connector at R. The resistance should vary from 0- to 2.2 kilo ohms as the potentiometer U on the controls is adjusted with the control levers squeezed. If these fail, the potentiometers will both need to be replaced.
Faulty drive control board	Test voltage at P should be from 34 to 38 VDC. If the voltage at P is good but the propel motor won't respond, and all the tests above have been done, replace the drive control board.
Faulty motor	Squeeze the control levers, adjust the potentiometer U, and test the voltage at X or Q. When the output voltage at X or Q varies from 0 to 24 volts but the motor does not respond, and all the tests above have been done, replace the motor.