

PARTS LIST

GALAXY 1500 BURNISHER

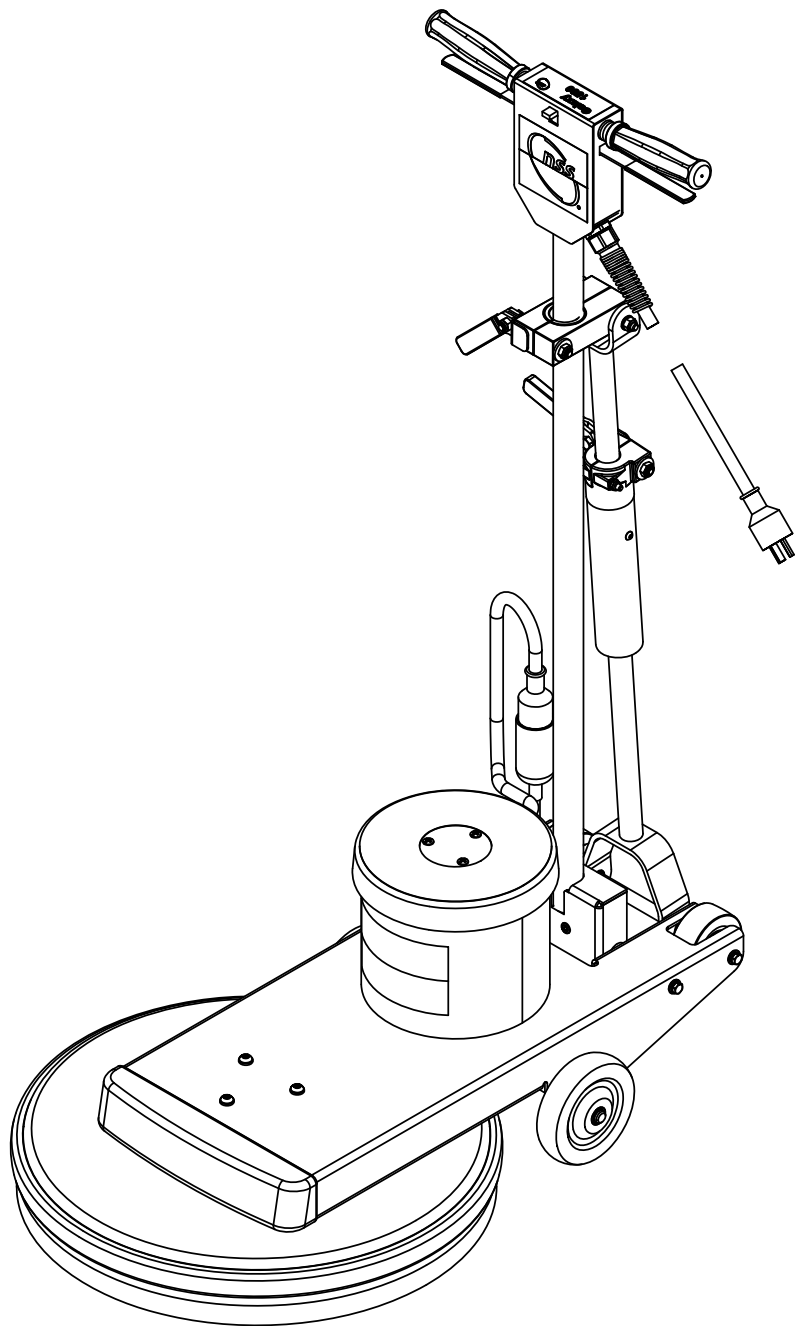

SPRING ROD ASSEMBLY

<u>ITEM</u>	<u>PART NO.</u>	<u>DESCRIPTION</u>	<u>QTY</u>
101	0393141	FLATTENED CLAMP BOLT	2
102	0393971	M8 X 1.25 X 25mm HEX BOLT	2
103	0395861	SLOTTED WASHER WITH TAB	2
104	0393121	CLAMP LEVER	2
105	0393321	HANDLE GRIP	2
106	0393961	M8 X 1.25 HEX NUT W/ NYLOK INSERT	2
107	0395331	HANDLE CLAMP, RIGHT	1
108	0395351	BUSHING, 32mm SPLIT	1
109	0395341	HANDLE CLAMP, LEFT	1
110	0393801	3/8-16 HEX NUT W/ NYLOK INSERT	1
111	0393831	3/8 SAE FLAT WASHER	1
112	0395501	M6 X 1.0 X 65mm HEX BOLT	1
113	0395511	M6 FLAT WASHER	1
114	0395481	ROD CLAMP	1
115	0395461	SHAFT COLLAR, 25mm	1
116	0395451	SPRING	1
117	0395551	M5 X 0.8 X 8mm SOCKET HEAD CAP SCREW	2
118	0395361	CYLINDER WELDMENT	1
119	0393641	BUSHING - LOWER HANDLE	2
120	0395511	M6 FLAT WASHER	1
121	0395521	M6 X 1.0 HEX NUT W/ NYLOK INSERT	1
122	0393801	3/8-16 HEX NUT W/ NYLOK INSERT	1
123	0393831	3/8 SAE FLAT WASHER	1
124	0395471	CYLINDER CAP	1
125	0395431	TOP CLEVIS/ROD WELDMENT	1
126	0393961	M8 X 1.25 HEX NUT W/ NYLOK INSERT	1
127	0393951	M8 FLAT WASHER	1
128	0395541	CLEVIS PIVOT BUSHING	2
129	0395531	M8 X 1.25 X 100mm HEX BOLT	1

SPRING ROD ASSEMBLY

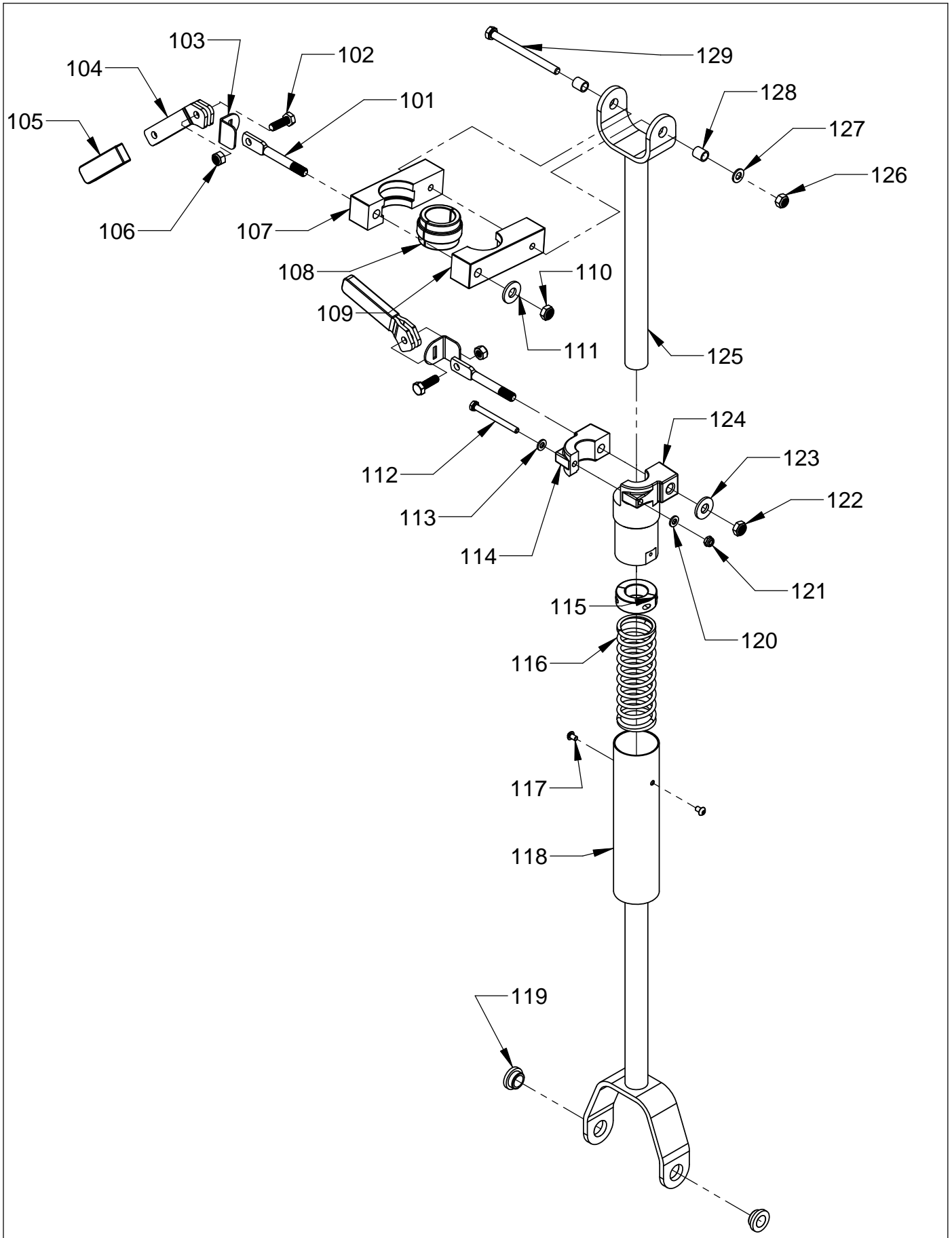

HANDLE ASSEMBLY

ITEM	PART NO.	DESCRIPTION	QTY
201	0393051	SAFETY DECAL	1
202	0395321	IDENTIFIER DECAL - GALAXY 1500	1
203	0393351	SWITCH BOX COVER	1
204	0393531	NSS DECAL	1
205	0393561	ROLL PIN	2
206	0393391	SWITCH LEVER SPRING	2
207	0393411	GRIP - SWITCH LEVER	2
208	0393401	SWITCH LEVER	1
209	0393521	SAFETY LOCKOUT	1
210	0393891	M4 FLAT WASHER	2
211	0393901	M4 X .07 HEX NUT W/ NYLOK INSERT	2
212	0393421	SWITCH INSULATOR	1
213	5390211	SWITCH	1
214	0393851	M3 FLAT WASHER	2
215	0393871	M3 X .05 X 25mm PAN HEAD PHILLIPS MACHINE SCREW	2
216	0393071	TERMINAL BLOCK - 240 VOLT ONLY	1
217	0393871	M3 X .05 X 25mm PAN HEAD PHILLIPS MACHINE SCREW	1
218	0393291	WIRE NUT (ORANGE)	1
219	0393091	WIRE - DEAD/TERMINAL - 240 VOLT ONLY	1
220	0393081	WIRE - GROUND/TERMINAL - 240 VOLT ONLY	1
221	0393901	M4 X .07 HEX NUT W/ NYLOK INSERT	1
222	0393891	M4 FLAT WASHER	1
223	0393331	CORD CLAMP	1
224	0393311	CORD CLAMP - CRIMP ON	1
225	8791071	VINYL TUBE - 240 VOLT ONLY	1
226	5390261	REPLACEMENT STRAIN RELIEF NUT	1
227	0393451	HANDLE CORD	1
228	0393631	PLUG/CORD COVER - HANDLE	1
229	0393341	CORD GROMMET	1
230	0393641	BUSHING - LOWER HANDLE	2
231	0393891	M4 FLAT WASHER	1
232	0393911	M4 X .07 X 16mm PAN HEAD PHILLIPS MACHINE SCREW	1
233	0393331	CORD CLAMP	1
234	0393891	M4 FLAT WASHER	1
235	0393901	M4 X .07 HEX NUT W/ NYLOK INSERT	1
236	0393371	HANDLE	1
237	0393461	CORD 50 OOT, 14-3 - 120 VOLT ONLY	1
	0393471	SHUKO CORD, 16-3 - 240 VOLT ONLY	1
238	0393491	CORD STRAIN RELIEF - 120 VOLT ONLY	1
	0393501	CORD STRAIN RELIEF - 240 VOLT ONLY	1
239	0393441	HANDLE GRIP	2
240	0393891	M4 FLAT WASHER	1
241	0393851	M3 FLAT WASHER - 240 VOLT ONLY	1
242	0393861	M3 X .05 HEX NUT WITH NYLOK INSERT - 240 VOLT ONLY	1
243	0393911	M4 X .07 X 16mm PAN HEAD PHILLIPS MACHINE SCREW	1
244	0393891	M4 FLAT WASHER	2
245	0393911	M4 X .07 X 16mm PAN HEAD PHILLIPS MACHINE SCREW	2
246	0393851	M3 FLAT WASHER	2
247	0393861	M3 X .05 HEX NUT WITH NYLOK INSERT	2
248	0393381	SPRING	1
249	0393511	SAFETY LOCKOUT BRACKET	1
250	0393841	M3 EXTERNAL STAR LOCK WASHER	2
251	0393881	M3 X .05 X 8mm PAN HEAD PHILLIPS MACHINE SCREW	2
252	0393931	M5 X .08 X 20mm PAN HEAD PHILLIPS MACHINE SCREW	2

HANDLE ASSEMBLY

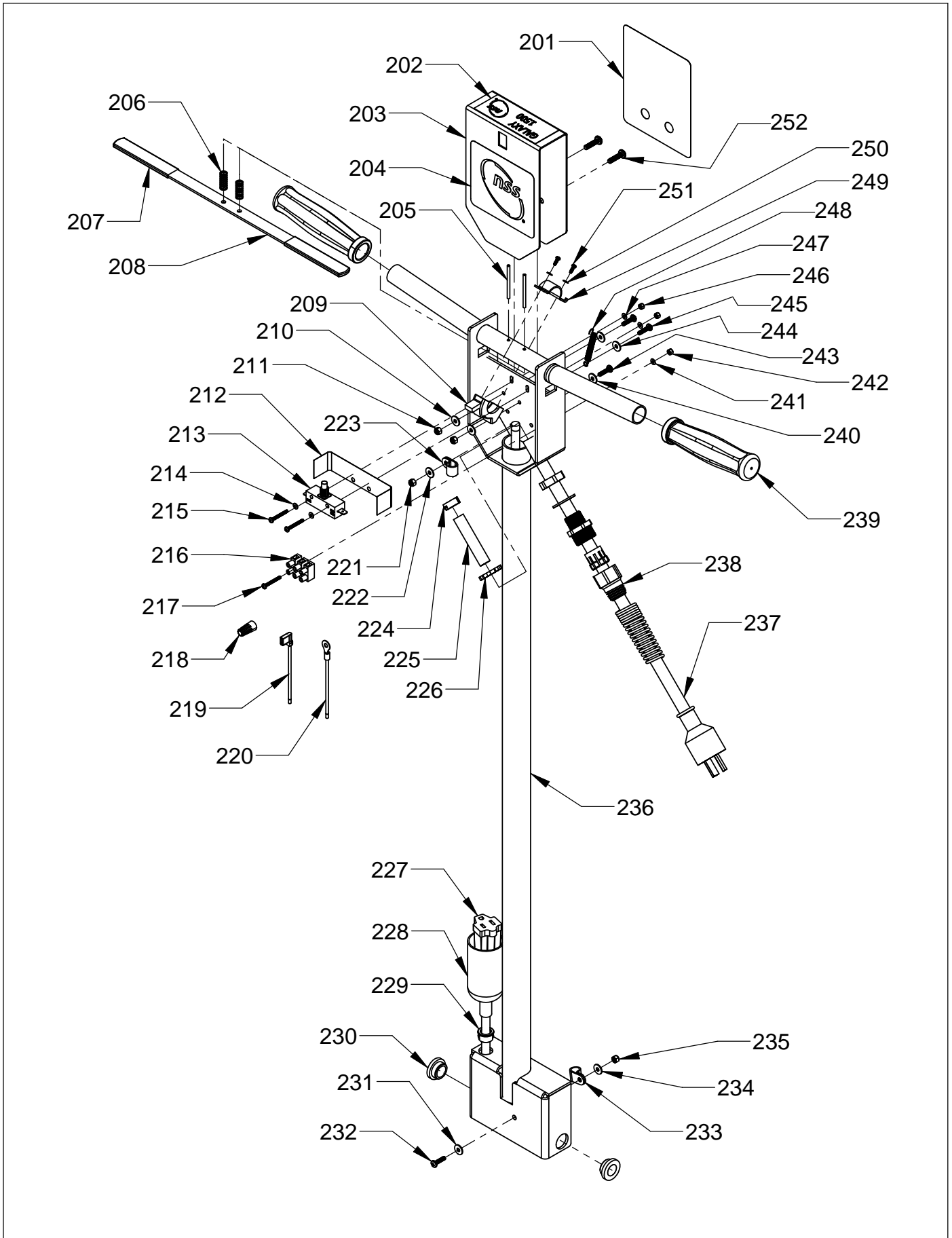

BASE/MOTOR ASSEMBLY

304	0394731	MOTOR COVER SPACER	1
305	5991511	MOTOR, 115 VOLT, 1.5 HP	1
	0395731	MOTOR, 230 VOLT, 1.5 HP	1
306	0393531	CLOUD BURST LABEL	1
307	0395931	M8 X 1.25 X 20mm BUTTON HEAD CAP SCREW	3
308	0395921	M8 SPLIT LOCK WASHER	3
309	0395231	PULLEY SHAFT	1
310	0395221	BEARING HOUSING	1
311	5990091	PULLEY COVER	1
312	0395201	BALL BEARING	2
313	0395261	BEARING SPACER	1
314	0395251	RETAINING RING	1
315	0395651	SKIRT	1
316	9120810	#10 X 1/2 PAN HD PHILLIPS SHEETMETAL SCREW - PK OF 10	3
317	9121520	5/16 SPLIT LOCK WASHER - PACK OF 10	4
318	9121640	5/16-18 X 3/4 HEX BOLT - PACK OF 5	4
319	0395831	BUMPER, 20"	1
320	5990759	FLEXIBLE PAD DRIVER ASSEMBLY - INCLUDES:	
	5990741	PAD DRIVER	1
321	5990751	PAD DRIVER PLATE	1
322	5990731	SPRING CLIP PAD HOLDER - INCLUDES:	1
323	9120140	#6 X 5/8 PAN HEAD PHILLIPS SHEET METAL SCREW	3
324	----	PAD - SEE ACCESSORIES PAGE FOR OPTIONS	1
325	9122450	1/2 SAE FLAT WASHER - PACK OF 5	1
326	9122507	1/2-13 HEX NUT W/ NYLOK INSERT - PACK OF 1	1
327	0395211	PULLEY - INCLUDES:	1
	9121043	1/4 X 1 1/8 ROLL PIN - PACK OF 5	4
328	9122030	3/8-16 X 3/4 BUTTON HD SOCKET CAP SCREW - PACK OF 2	4
329	9122100	3/8 SPLIT LOCK WASHER - PACK OF 10	4
330	9121980	3/8 SAE FLAT WASHER - PACK OF 2	4
331	5294501	BELT	1
332	5294491	MOTOR PULLEY - INCLUDES:	1
333	9121380	5/16-18 X 3/8 KNURL POINT SET SCREW	1
334	0393251	RETAINING RING	2
335	0393231	5" SOFT GRAY RUBBER WHEEL	2
336	0395271	AXLE	1
337	9121170	1/4-20 X 1/2 LONG HEX HEAD BOLT - PACK OF 10	4
338	9120880	1/4 SPLIT LOCK WASHER - PACK OF 10	4
339	9120930	1/4 SAE FLATWASHER - PACK OF 10	4
340	0395281	HANDLE SHAFT	2
341	0395301	REAR WHEEL SPACER	4
342	0395291	3" WHEEL	2
343	0395241	GALAXY 1500 FRAME	1
344	0395801	ANTI-ROTATION LOCK TAB	1
345	0395811	M3 LOCK WASHER	1
346	0395821	M3 X .05 X 6mm LONG BUTTON HEAD CAP SCREW	1

BASE/MOTOR ASSEMBLY

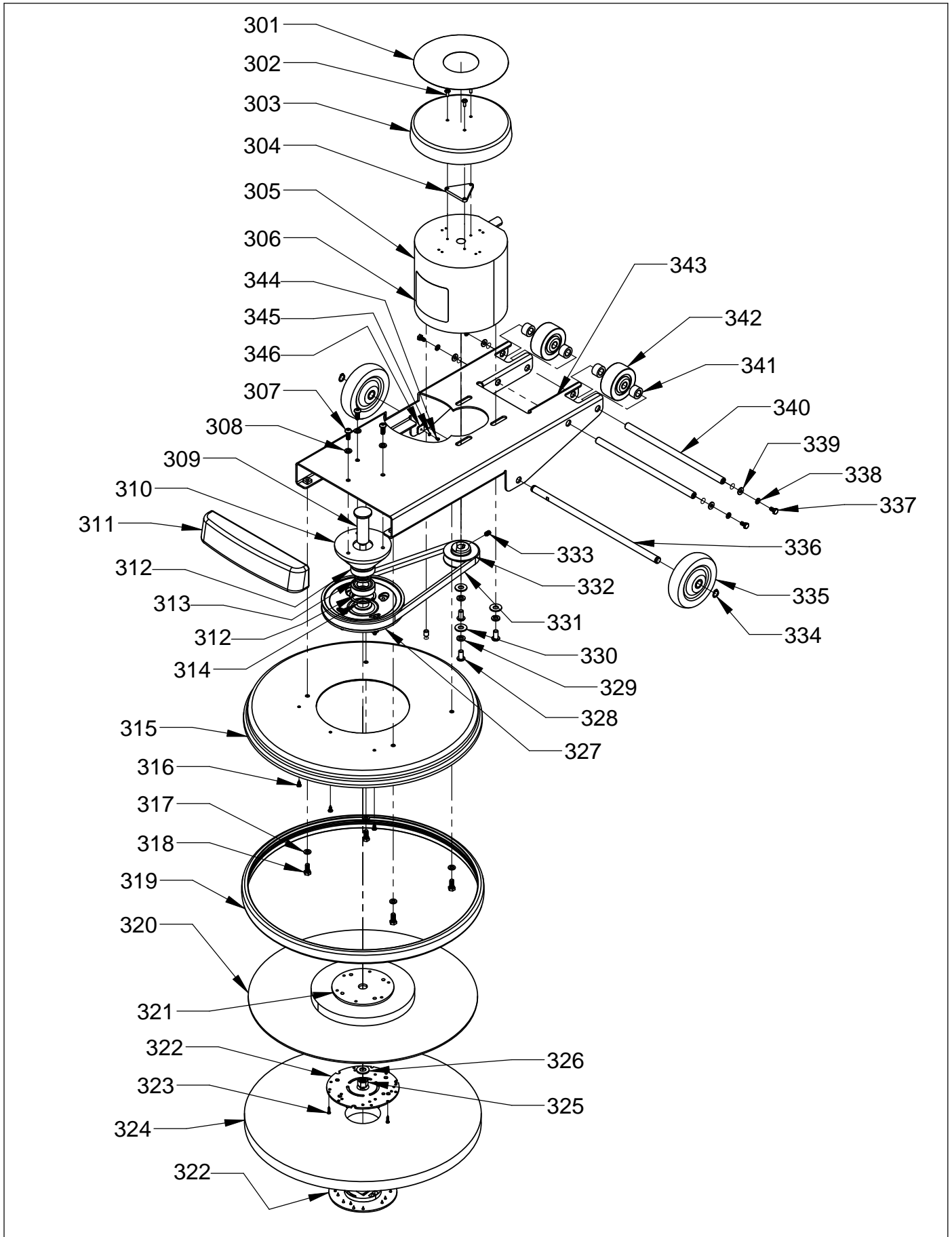

MOTOR ASSEMBLY

<u>ITEM</u>	<u>PART NO.</u>	<u>DESCRIPTION</u>	<u>QTY</u>
	<u>5991511</u>	<u>COMPLETE MOTOR - 115 VOLT - 1.5 HP</u>	
401	5991581	COMMUTATOR BRACKET ASSEMBLY WITH BRUSH, BOARD, LEADS	1
	5991571	COMMUTATOR BRACKET	1
	5991731	COMMUTATOR BRACKET COVER	1
402	5991701	THRU BOLT	2
403	5991611	BRUSH BOARD ASSY WITH BRUSHES, SPRINGS, DETECTORS, LEADS	1
	5991641	VARISTOR ASSEMBLY WITH SLEEVING AND TERMINALS	1
404	5991621	RED LEAD ASSEMBLY	1
405	5991631	YELLOW LEAD ASSEMBLY	1
406	5293851	CARBON BRUSH	1
407	2797571	BRUSH SPRING	1
408	5991601	10-24 X 1/2 SELF TAPPING SCREW	4
409	5991721	BRACKET - BOTTOM END	1
410	5991711	SHAFT KEY	1
411	5991531	ARMATURE ASSEMBLY INCLUDES:	1
412	5991541	BEARING - BOTTOM END	1
413	5991551	BEARING - TOP END	1
414	5991741	HELICAL WASHER	1
415	5991521	STATOR FRAME ASSEMBLY - WITH CLIPS AND MAGNETS	1
416	5991661	8-32 X 1.125 MOUNTING SCREW	1
417	5991671	M8 FLAT WASHER - BRASS	1
418	5991651	RECTIFIER	1
419	5991681	HEX NUT WITH STAR LOCK WASHER	1
420	5991581	HOLE PLUG	1
421	5991691	MOTOR CORD	1
422	5991591	STRAN RELIEF	1
	<u>0395731</u>	<u>COMPLETE MOTOR 230 VOLT - 1.5 H.P.</u>	
401	0396011	COMMUTATOR BRACKET ASSEMBLY WITH BRUSH, BOARD, LEADS	1
	0396021	COMMUTATOR BRACKET	1
	5991731	COMMUTATOR BRACKET COVER	1
	0396031	COMMUTATOR BRACKET COVER SCREW	4
402	5991701	THRU BOLT	2
403	396041	BRUSH BOARD ASSY WITH BRUSHES, SPRINGS, DETECTORS, LEADS	1
	396051	VARISTOR ASSEMBLY WITH SLEEVING AND TERMINALS	1
404	5991621	RED LEAD ASSEMBLY	1
405	396061	YELLOW LEAD ASSEMBLY	1
406	396071	CARBON BRUSH	4
407	396081	BRUSH SPRING	4
408	5991601	10-24 X 1/2 SELF TAPPING SCREW	5
409	5991721	BRACKET - BOTTOM END	1
410	5991711	SHAFT KEY	1
411	396091	ARMATURE ASSEMBLY INCLUDES:	1
412	5991541	BEARING - BOTTOM END	1
413	5991551	BEARING - TOP END	1
414	5991741	HELICAL WASHER	1
415	5991521	STATOR FRAME ASSEMBLY - WITH CLIPS AND MAGNETS	1
416	5991661	8-32 X 1.125 MOUNTING SCREW	1
417	5991671	M8 FLAT WASHER - BRASS	1
418	396101	RECTIFIER	1
419	5991681	HEX NUT WITH STAR LOCK WASHER	1
420	396111	HOLE PLUG	1
421	5991691	MOTOR CORD	1
422	5991591	STRAN RELIEF	2

MOTOR ASSEMBLY

115/230 VOLT MOTOR

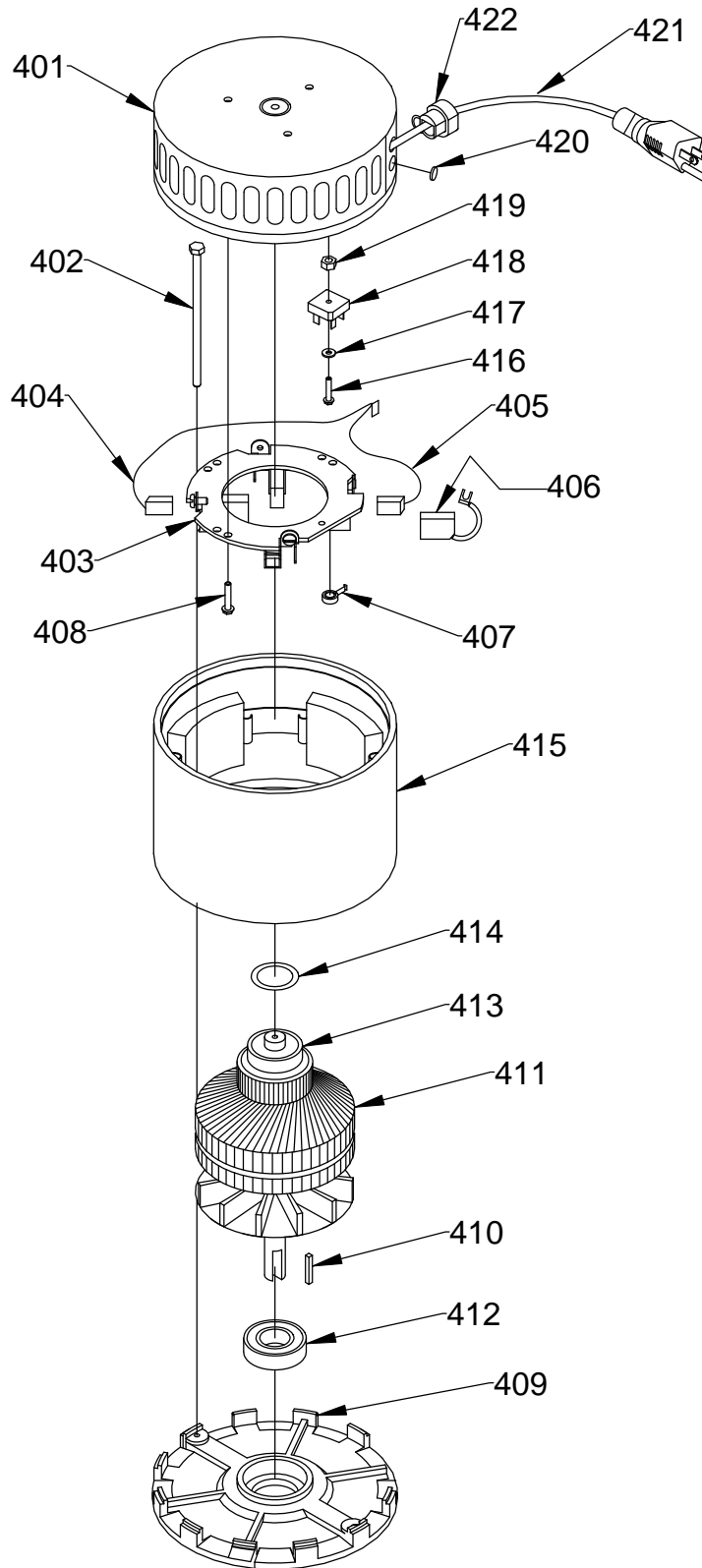

WIRING DIAGRAM

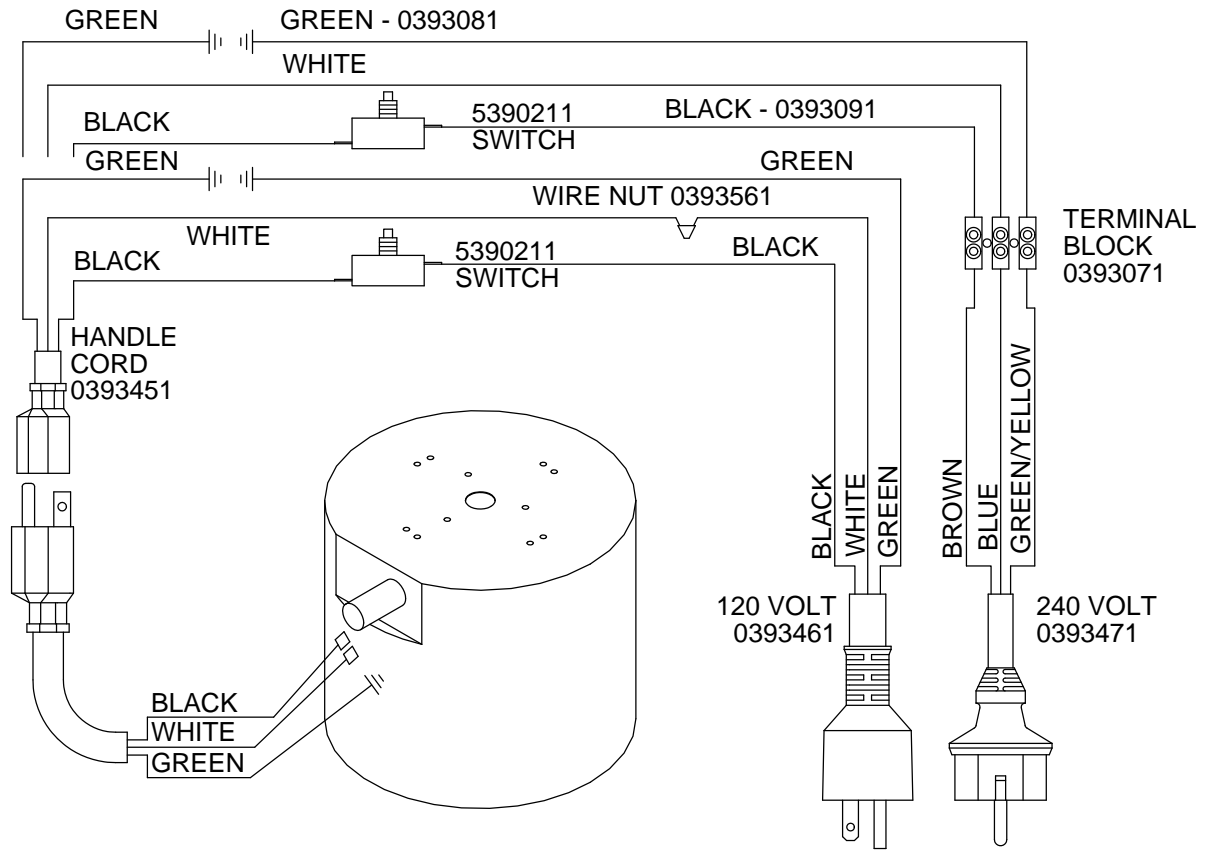

ACCESSORIES



PART NO.

NOTE:

7992051

7992061

7992081

7992091

7992021

7992001

7992011

PART DESCRIPTION

ALL PADS COME 5 PADS PER CASE

20" LITE BLUE POLISH/BURNISH PAD - FOR SOFT FINISH

20" LITE HAIR BURNISH PAD - FOR ALL FINISHES

20" ULTRA HAIR HARD FINISH PAD - FOR HARD FINISH

20" ULTIMATE HAIR PAD - HARD FINISH AGGRESSIVE BURNISHING

20" GREEN SCRUB PAD - HEAVY FINISH REMOVAL

20" BLACK STRIP PAD - REMOVES FINISH COMPLETELY

20" BROWN STRIP PAD - REMOVES FINISH COMPLETELY

NOTES



NSS® Enterprises, Inc.

3115 Frenchmens Road, Toledo, Ohio 43607
® PHONE (419) 531-2121 FAX (419) 531-3761

NSS® Enterprises, Inc. European Distribution Centre
Unit II, Pinfold Trading Estate * 55 Nottingham Road
STAPLEFORD, NOTTINGHAM NG9 8AD ENGLAND U.K.
PHONE: (44) 0115 939 1568 * FAX: (44) 0115 949 0615