

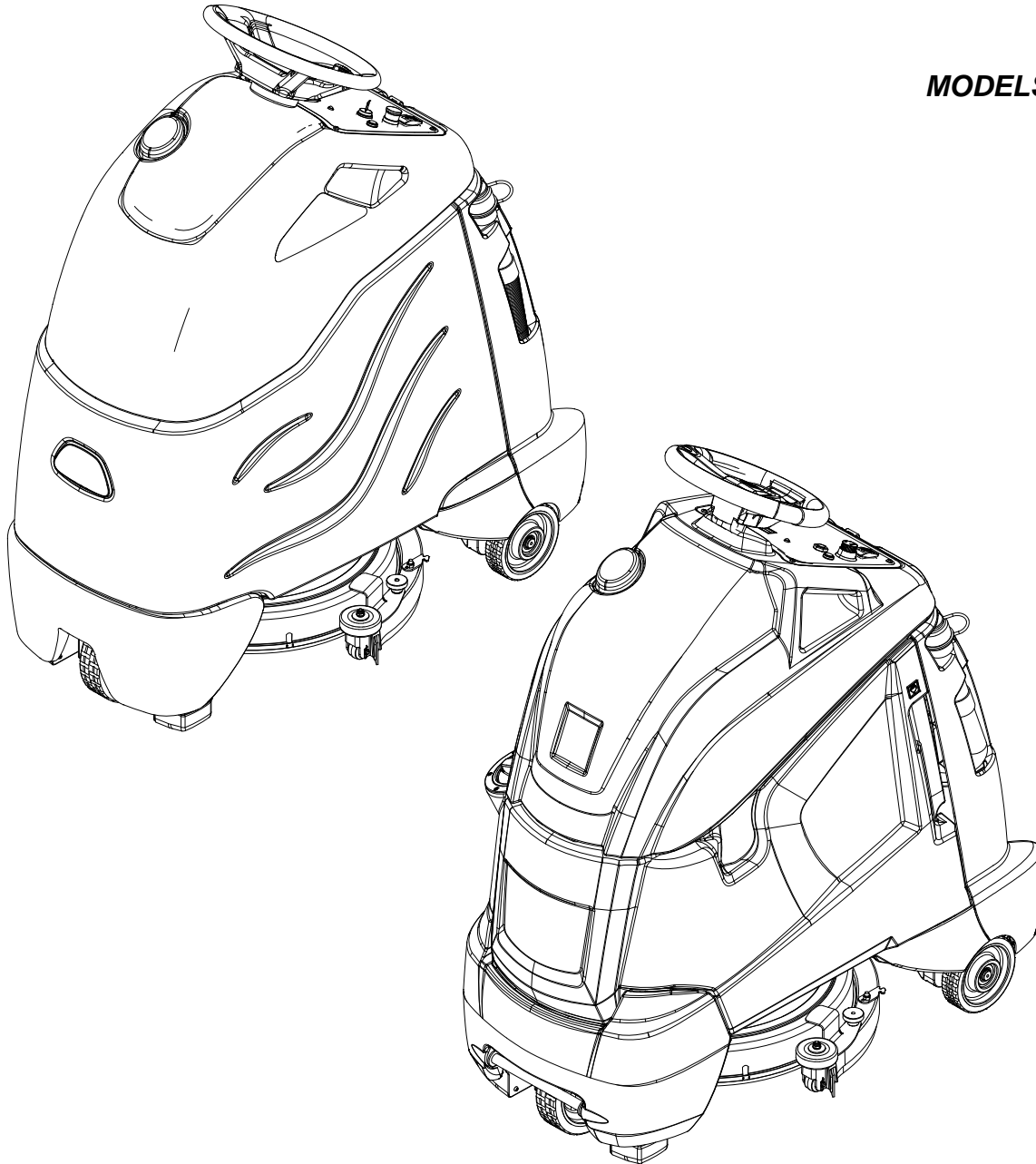

chariot

iScrub 20

Operating instructions (ENG)



MODELS: CS20
10061250

CSC20
10061330

CSX20
10061370

CSXC20
10061380

Read these instructions before using the machine.



Model: _____

Date of Purchase: _____

Serial Number: _____

Dealer: _____

Address: _____

Phone Number: _____

Sales Representative: _____

OVERVIEW

The Chariot Scrubber is a battery powered, stand-on, hard floor scrubber intended for commercial use. The appliance applies a cleaning solution onto a hard floor, scrubs the floor with brush or pad, and then vacuums the soiled water back into the recovery tank.

Machine Data Log/Overview 2
Table of Contents 3
How to Use This Manual 4

Safety

IMPORTANT SAFETY INSTRUCTIONS 5
HAZARD INTENSITY LEVEL 6
Safety Label Locations 7

Operations

Technical Specifications 8
How This Machine Works 10
Components 11
Drive Controls 12
Scrub Controls 16
Scrub Controls-Squeegee 18
Pre-Run Machine Inspection 20
Starting Machine 20
Emergency Stop Procedure 20
Filling Solution Tank 20
Filling Solution Tank (Deluxe) 20
Normal Scrubbing 21
To Begin Scrubbing 21
To Stop Scrubbing 22
Double Scrub 22
Emptying and Cleaning Tanks 23

Maintenance

Service Schedule 24
Batteries 25
Battery Charger Programming 29
Squeegee Blades 31
To Remove Squeegee Assembly 31
Scrub Brush 31
Finished Floors 31
Scrub Deck 32
To Replace Scrub Brush Motor 33
Scrub Deck Actuator Removal / Replacement 34
Circuit Protection 35
Solution 36
Tank Assembly Removal 38
Drive Unit Removal 39
Vacuum & Float Shutoff 40
Vacuum Motor Carbon Brush Replacement 41
Drive Motor 42
Drive Motor Carbon Brush Replacement 42
Drive Chain Tension 42
Transporting 42
Inclines 43
Machine Tie-Downs 44
Machine Tie-Downs (Deluxe) 45
Troubleshooting 46
Battery Discharge Indicator Troubleshooting 48

Parts

Bumper 50
Bumper-Deluxe 52
Console 54
Control Panel 56
Decals 60
Decals-Deluxe 62
Drive-Lower 64
Drive-Chain 66
Drive Mounting 68
Frame & Rear Wheels 70
On Board Battery Charger-CSC20 72
On Board Battery Charger-CSXC20 74
Pedal Platform 76
Pedal Platform Mounting 78
Recovery Tank 80
Scrub Brush/Pad Driver 82
Scrub Brush Deck 84
Scrub Brush Deck Mounting 86
Scrub Deck Lift 88
Solution Tank 90
Solution Tank-Deluxe 92
Squeegee 94
Steering 96
Vacuum 98
Wiring-Battery 100
Wiring-Diagram -From Serial No. *(5) 102
Wiring-Diagram -From Serial No. *(5) 112
Wiring-Diagram -From Serial No. *(5) 114
Wiring-Diagram -From Serial No. *(5) 116
Wiring-Control Panel -Prior to Serial No. *(5) ... 118
Wiring-Main Harness -Prior to Serial No. *(5) ... 120
Wiring-Diagram -Prior to Serial No. *(5) 122
Wiring-Diagram -Prior to Serial No. *(5) 124
Suggested Spare Parts 125
Serial Numbers 126

How to Use This Manual

This manual contains the following sections:

- HOW TO USE THIS MANUAL
- SAFETY
- OPERATIONS
- MAINTENANCE
- PARTS LIST

The HOW TO USE THIS MANUAL section will tell you how to find important information for ordering correct repair parts.

Parts may be ordered from authorized Windsor dealers. When placing an order for parts, the machine model and machine serial number are important. Refer to the MACHINE DATA box which is filled out during the installation of your machine. The MACHINE DATA box is located on the inside of the front cover of this manual.

Model:	_____
Date of Purchase:	_____
Serial Number:	_____
Dealer:	_____
Address:	_____
Phone Number:	_____
Sales Representative:	_____

The model and serial number of your machine are located below the battery compartment of the machine.

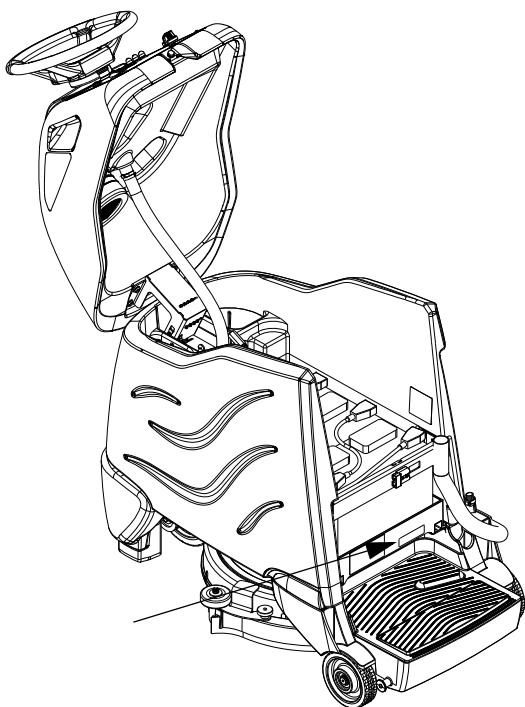

The SAFETY section contains important information regarding hazard or unsafe practices of the machine. Levels of hazards are identified that could

result in product or personal injury, or severe injury resulting in death.

The OPERATIONS section is to familiarize the operator with the operation and function of the machine.

The MAINTENANCE section contains preventive maintenance to keep the machine and its components in good working condition. They are listed in this general order:

- Batteries
- Scrub Brush
- Squeegee
- Service Schedule
- Machine Troubleshooting

The PARTS LIST section contains assembled parts illustrations and corresponding parts list. The parts lists include a number of columns of information:

REF - column refers to the reference number on the parts illustration.

PART NO. - column lists the part number for the part.

PRV NO. - Reference No.

QTY - column lists the quantity of the part used in that area of the machine.

DESCRIPTION - column is a brief description of the part.

SERIAL NO. FROM - If this column has an (*) and a Reference number, see the SERIAL NUMBERS page in the back of your manual. If column has two asterisk (**), call manufacturer for serial number.

The serial number indicates the first machine the part number is applicable to. The main illustration shows the most current design of the machine.

When a boxed illustration is shown, it displays the older design.

NOTES - column for information not noted by the other columns.

NOTE: If a service or option kit is installed on your machine, be sure to keep the KIT INSTRUCTIONS which came with the kit. It contains replacement parts numbers needed for ordering future parts.

NOTE: The number on the lower left corner of the front cover is the part number for this manual.

IMPORTANT SAFETY INSTRUCTIONS

When using an battery powered appliance, basic precaution must always be followed, including the following:

READ ALL INSTRUCTIONS BEFORE USING THIS MACHINE.

⚠ WARNING:

To reduce the risk of fire, electric shock, or injury:

Use only indoors. Do not use outdoors or expose to rain.

Use only as described in this manual. Use only manufacturer's recommended components and attachments.

If the machine is **not working properly**, has been dropped, damaged, left outdoors, or dropped into water, return it to an authorized service center.

Do not operate the machine with any openings blocked. Keep openings free of debris that may reduce airflow.

This machine **is not** suitable for picking up hazardous dust.

Machine can cause a fire when operating near flammable vapors or materials. Do not operate this machine near flammable fluids, dust or vapors.

This machine is suitable for commercial use, for example in hotels, schools, hospitals, factories, shops and offices for more than normal housekeeping purposes.

Maintenance and repairs **must be done** by qualified personnel.

If foam or liquid comes out of machine, **switch off immediately**.

Disconnect battery before cleaning or servicing.

Before the machine is discarded, the batteries **must be removed** and properly disposed of.

Make sure all warning and caution labels **are legible and properly attached** to the machine.

During operation, attention shall be paid to other persons, especially children.

Before use all covers and doors shall be put in the positions specified in the instructions.

When leaving unattended, secure against unintentional movement.

The machine shall only be operated by instructed and authorized persons.

When leaving unattended, switch off or lock the main power switch to prevent unauthorized use.

Only chemicals recommended by the manufacturer shall be used.

This appliance has been designed for use with the brushes specified by the manufacturer. The fitting of other brushes may affect its safety.

Do not use on surfaces having a gradient of over 10% (6 degrees).

SAVE THESE INSTRUCTIONS

The following symbols are used throughout this guide as indicated in their descriptions:

HAZARD INTENSITY LEVEL

There are three levels of hazard intensity identified by signal words -**WARNING** and **CAUTION** and **FOR SAFETY**. The level of hazard intensity is determined by the following definitions:

⚠ WARNING:

WARNING - Hazards or unsafe practices which **COULD** result in severe personal injury or death.

⚠ CAUTION:

CAUTION - Hazards or unsafe practices which could result in minor personal injury or product or property damage.

FOR SAFETY: To Identify actions which must be followed for safe operation of equipment.

Report machine damage or faulty operation immediately. Do not use the machine if it is not in proper operating condition. Following is information that signals some potentially dangerous conditions to the operator or the equipment. Read this information carefully. Know when these conditions can exist. Locate all safety devices on the machine. Please take the necessary steps to train the machine operating personnel.

FOR SAFETY:

DO NOT OPERATE MACHINE:

Unless Trained and Authorized.

Unless Operation Guide is Read and understood.

In Flammable or Explosive areas.

In areas with possible falling objects.

WHEN SERVICING MACHINE:

Avoid moving parts. Do not wear loose clothing; jackets, shirts, or sleeves when working on the machine. Use Windsor approved replacement parts.

⚠ WARNING:

Batteries emit hydrogen gas. Explosion or fire can result. Keep sparks and open flame away. Keep solution tank in raised position when charging. Keep sparks and flames away from the batteries. Do not smoke around batteries.

⚠ WARNING:

Disconnect batteries before working on machine. Only qualified personnel should work inside machine. Always wear eye protection and protective clothing when working on or near batteries. Avoid skin contact with the acid contained in the batteries.

⚠ WARNING:

Never allow metal to lie across battery tops.

Safety Label Locations

These drawings indicate the location of safety labels on the machine. If at any time the labels become illegible, promptly replace them.

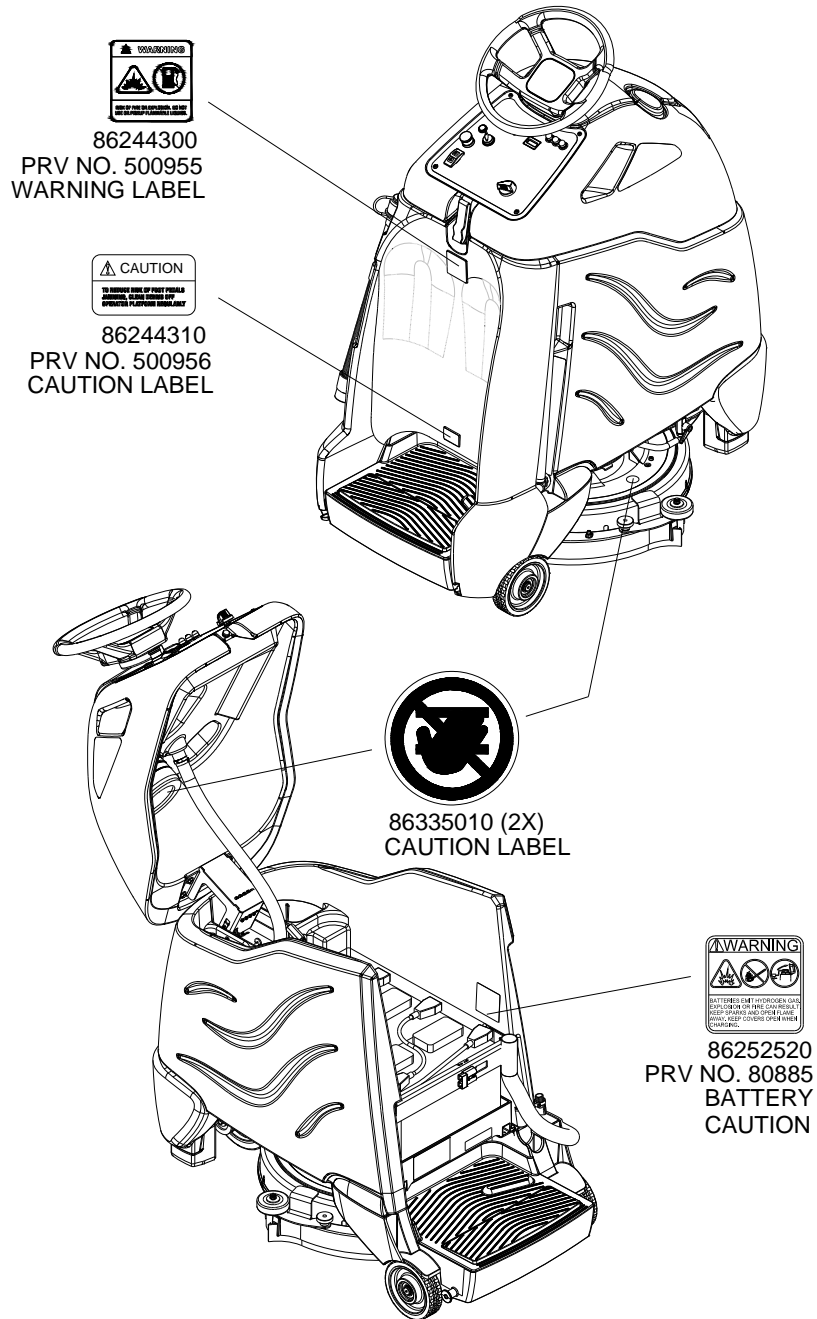

Technical Specifications

ITEM	DIMENSION/CAPACITY
Nominal power	1080 W
Rated Voltage	36 Volts DC
Rated Amperage	30 amps
Batteries	3 X12 Volt 130 AH @ 20 hr. rate
Battery Compartment Dimensions	20-1/2 in. x 13 in. x 10 in. tall (330mm x 521mm x 254mm)
Scrub Brush Motor - Disk Machine	1 x .28 HP (209 W)
Vacuum Motor	.63 HP (470 W)
Maximum flow rate of vacuum motor	72 cfm (33.98 liters per second)
Maximum suction of vacuum motor	47.3 inches of water (11.7 kPa)
Propelling Motor	.21 HP (157 W)
Mass (GVW)	726 lbs (330 kg)
Weight empty without batteries	209 lbs (96 kg)
Solution Control	Gravity, 1/3 GPM average
Solution capacity	10 gal (38 L)
Recovery capacity	10 gal (38 L)
Scrub brush diameter - Disk Machine	20 inch (508 mm)
Scrub brush pressure	50 lbs (222N)
Scrub brush speed - Disk Machine	180 rpm
Tires	8 in. (203mm) drive, 6 in. (156mm) rear, polyurethane
Maximum Speed	2.7 mph (4.3 Km/hour)
Theoretical Coverage	19,800ft ² /hr @ 2.5 mph with 2 in. overlap
Brake	Electrical parking brake, sets automatically whenever operator stops.
Minimum aisle u-turn width	51in. (1295 mm)
Maximum rated climb and descent angle	10% (6 degrees)

ITEM	MEASURE
Height	51.8 in (1316mm)
Length	44.0 in (1118mm)
Width without squeegee	23.4 in (594mm)
Width of squeegee	27.2 in (691mm)
Width of scrub path	20 in (508mm)

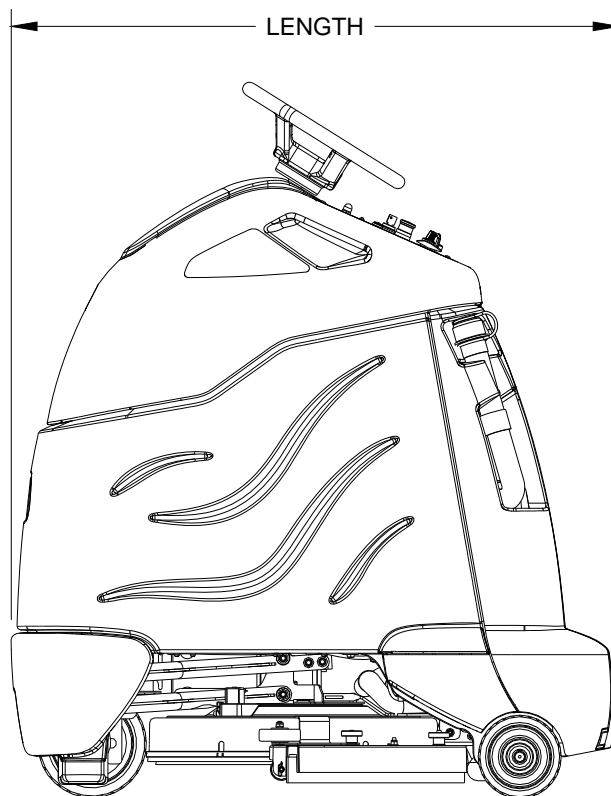
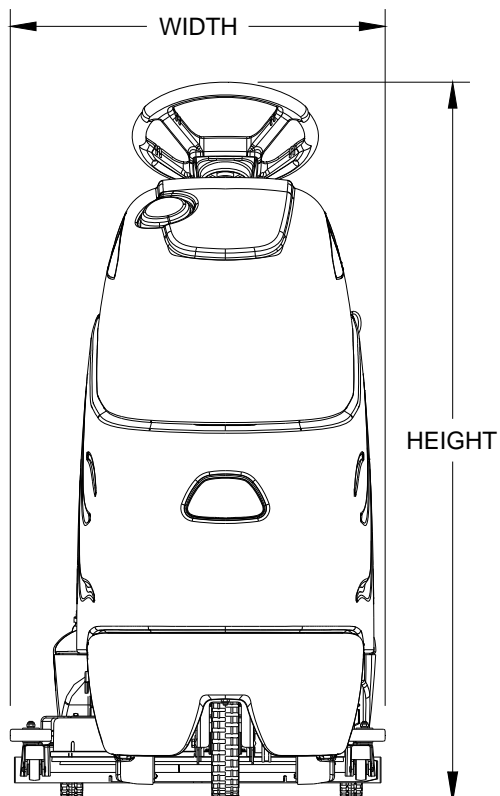

SPECIAL NOTES:

The sound pressure level at the operator's ear was measured to be 66.9 dBA. This was a nearfield, broadband measurement taken in a typical industrial environment on a tile floor. This appliance contains no possible source of impact noise. The instantaneous sound pressure level is below 63 Pa.

The weighted root mean square acceleration at the operator's arms was measured to be below 2.5m/s². This was a tri-axial, third-octave-band measurement made during normal operation on a composite tile floor. The measurement and related calculations were made in accordance with ANSI S3.34-1986.

This appliance is not intended for use by persons (including children) with reduced physical, sensory or mental capabilities, or lack of experience and knowledge, unless they have been given supervision or instruction concerning use of the appliance by a person responsible for their safety. Children should be supervised to ensure that they do not play with the appliance.

How This Machine Works

The Chariot® is a battery powered, self-propelled, hard floor scrubber intended for commercial use. The appliance applies a cleaning solution onto a hard floor, scrubs the floor with a brush, and then vacuums the soiled water back into the recovery tank.

The machine's primary systems are the solution system, scrub system, recovery system, and operator control system.

The function of the solution system is to store cleaning solution and deliver it to the scrub system. The solution system consists of the solution tank, strainer, metering valve and solenoid valve. The solution tank stores cleaning solution (water and detergent) until it is delivered to the scrub system. The strainer protects the valves from debris. The solenoid valve automatically prevents solution flow unless the scrub brush is turned on and the machine is being propelled.

The function of the scrub system is to scrub the floor. The disk scrub system consists of one rotary type disk scrub brush, motor, scrub deck skirt and lift actuator. The brush scrubs the floor as the motor drives the brush. The brush drive hub allows the scrub brush to follow irregularities and changes in the floor without losing contact with the floor. The scrub deck skirt controls the cleaning solution on the floor so that the squeegee can pick it up.

The function of the recovery system is to vacuum the soiled water back into the recovery tank. The recovery system consists of the squeegee, vacuum motor, float ball, recovery tank. The squeegee wipes the dirty solution off the floor as the machine moves forward. The vacuum motor provides suction to draw the dirty solution off the floor and into the recovery tank. The float ball filter protects the vacuum fan from debris and foam. The recovery tank stores the dirty solution.

The function of the operator control system is to control the direction and speed of the machine. The directional control system consists of the direction control drive reset switch, throttle pedal, emergency stop/brake switch, steering wheel, propel controller, and drive wheel. The directional control drive reset switch signals forward or reverse direction and makes sure the operator is on the platform before machine will propel. The controller interprets signals from the throttle pedal to command the drive wheel to propel or slow the machine. The steering wheel points the drive wheel in the direction desired by the operator. The parking brake automatically engages when the operator stop the machine. The emergency stop/brake can be used to hold the machine on slopes.

Components

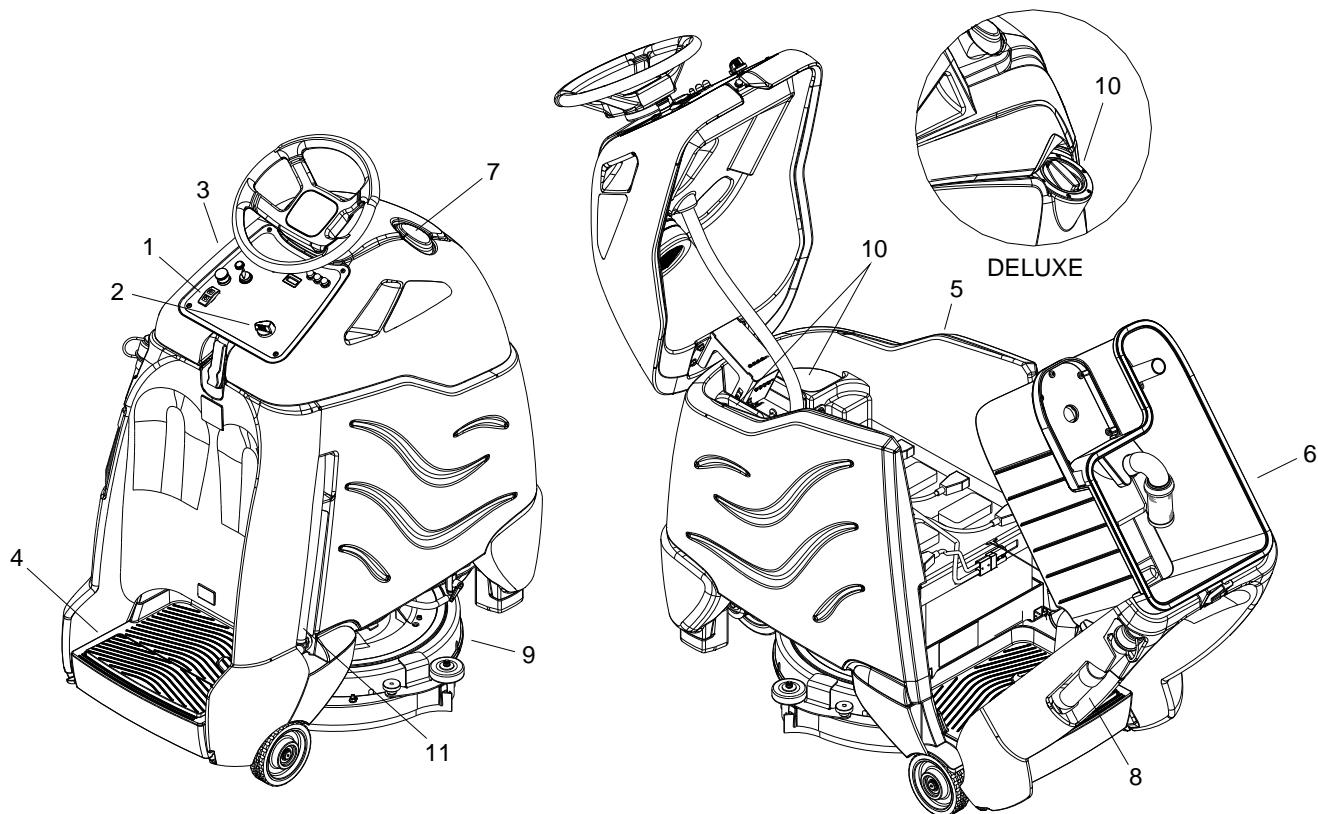

- 1. Drive Control
- 2. Scrub Controls
- 3. Control Console
- 4. Pedal Platform
- 5. Solution Tank
- 6. Recovery Tank

- 7. Recovery Sight Dome
- 8. Recovery Drain Hose
- 9. Scrub Deck Skirt
- 10. Solution Cover
- 11. Solution Drain Hose/Solution Level Indicator

Drive Controls

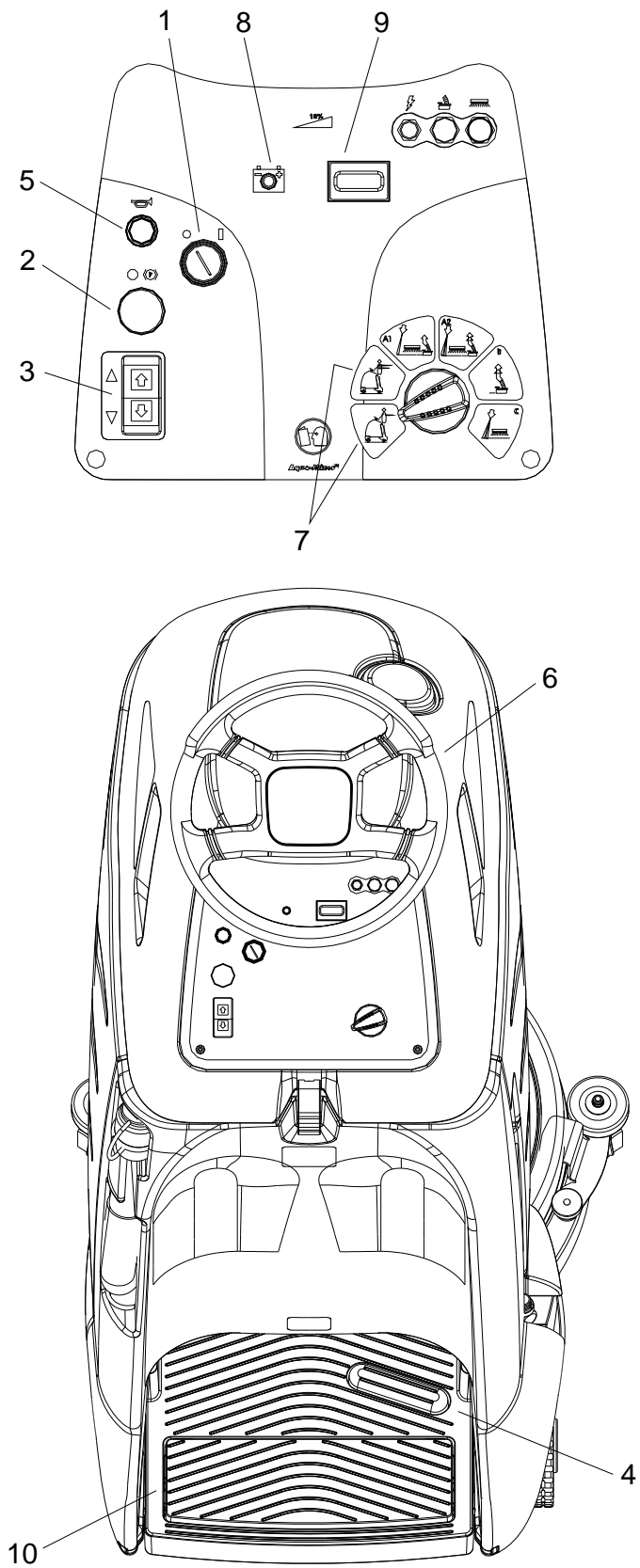

- | | |
|---|--------------------------------|
| 1. Key Switch | 6. Steering Wheel |
| 2. Emergency Stop/Brake Switch | 7. Speed Control |
| 3. Directional Control / Drive Reset Switch | 8. Battery Discharge Indicator |
| 4. Throttle Pedal | 9. Hour Meter |
| 5. Horn Button | 10. Operator Presence Switch |
-

1. KEY SWITCH

Controls the power for machine functions.

To turn the machine power on, rotate key clockwise.

To turn the machine off, rotate key counterclockwise.

When the key is turned on the battery symbol will flash once and stay on continuously.

2. EMERGENCY STOP/BRAKE SWITCH

This safety feature is designed to cut all power to the machine at any time and apply parking brake.

To shut the machine power off, push the Emergency Stop Switch, this will also engage the parking brake and cause the machine to stop immediately.

To reset the machine, rotate the switch clockwise.

3. DIRECTIONAL CONTROL / DRIVE RESET SWITCH

This safety feature is designed to ensure safe engagement of propel drive. Each time the machine power is turned on, or each time an operator steps on to the platform, the Drive Reset Switch must be pushed before machine will propel.

The switch controls the direction of travel of the vehicle. The lighted arrow on the switch indicates direction of travel.

To travel forward, press the top of the switch.

To travel in reverse, press the bottom of the switch.

4. THROTTLE PEDAL

Controls the speed of the vehicle within the speed control setting selected. Pressing the pedal causes the machine to travel in the direction selected by the Directional Control Switch.

To increase speed, increase pressure on the pedal.

To decrease speed, decrease pressure on the pedal.

5. HORN BUTTON

The horn is activated by pressing the horn button.

6. STEERING WHEEL

The steering wheel turns the front wheel causing the machine to change direction.

7. SPEED CONTROL

Controls the maximum speed of the machine. There are two settings, slow and fast.

To change speed, rotate the dial to either slow or fast position. The slow position is to the left (counterclockwise), fast to the right (top position).

The throttle pedal will always regulate the speed between 0 and maximum

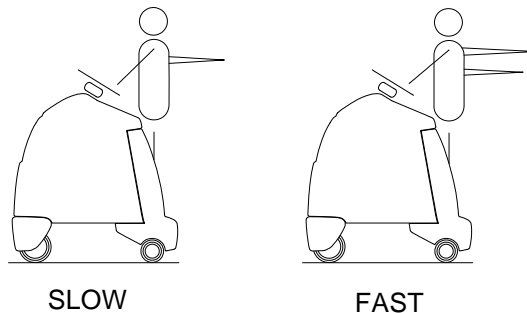

8. BATTERY DISCHARGE INDICATOR

Indicates the charge level of the batteries.

The indicator will be illuminated if the batteries have a sufficient charge. A slow, continuous flash indicates the batteries require charging.

The Battery Lockout function will activate when the batteries are low.

Once active, the LED status indicator will begin to flash slowly and the controller will inhibit the scrub motor and water solenoid. The vacuum and drive remain functional. The "vacuum only" selection (position 'B') can be used to vacuum up any remaining water. Return the unit to the charging station and charge the batteries.

NOTE: *Continuing usage may damage the batteries.*

When the machine is left overnight with less than a full charge, the display may initially indicate a full charge. It will also indicate a full charge if the batteries are disconnected, then reconnected. After a few minutes of operation the indicator will give the correct charge level.

9. HOUR METER

Records the number of hours the machine has been in scrubbing operation. This information is useful in determining when to service the machine.

Scrub Controls

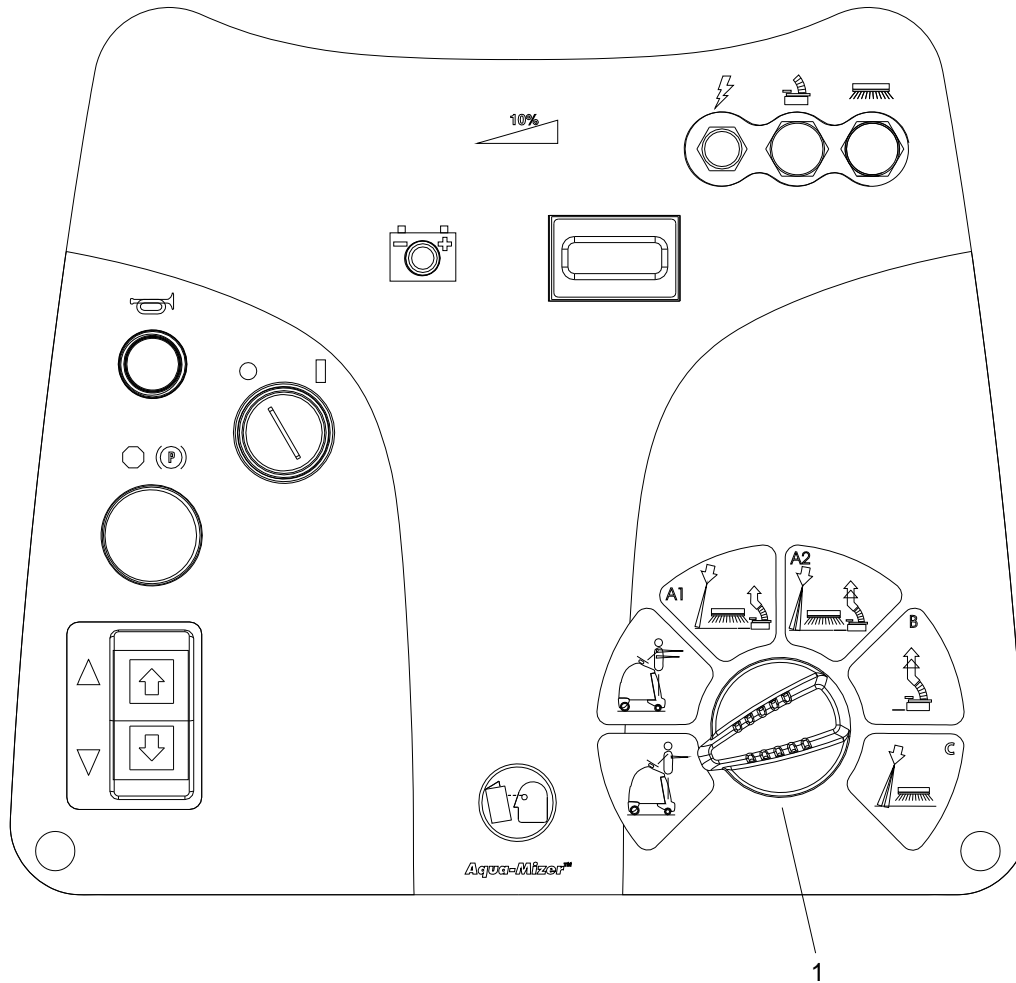

1. FUNCTION MODE SWITCH

The first two positions are for transport only. See drive controls section.

A1 - Light cleaning

This mode is used for light cleaning. In this mode the machine will propel at fast speed. The 'floating' scrub deck and squeegee is in the down position. The water will flow. Water will automatically shut off in neutral and restarts when scrubbing is resumed. The vacuum will draw the water into the recovery tank.

A2 - Deep cleaning

This mode is used for deep cleaning. In this mode the machine will propel at a low speed. The 'floating' scrub deck and squeegee is in the down position. The water will flow. Water will automatically shut off in neutral and restarts when scrubbing is resumed. The vacuum will draw the water into the recovery tank.

B - Vacuum only mode

This mode is used for picking up solution only. The brush and water will both be up and off. In this mode the machine will propel at fast speed. The squeegee is lowered and the vacuum will come on.

C - Double Scrub cleaning

This mode is used for putting down solution and scrubbing without picking it back up. The squeegee is set manually by connecting the two double scrub support cables. In this mode the machine will propel at a slow speed. The scrub deck will lower. The solution will flow. The brush and water will shut off when the machine is in neutral. They will resume when propelling is resumed.

Scrub Controls-Squeegee

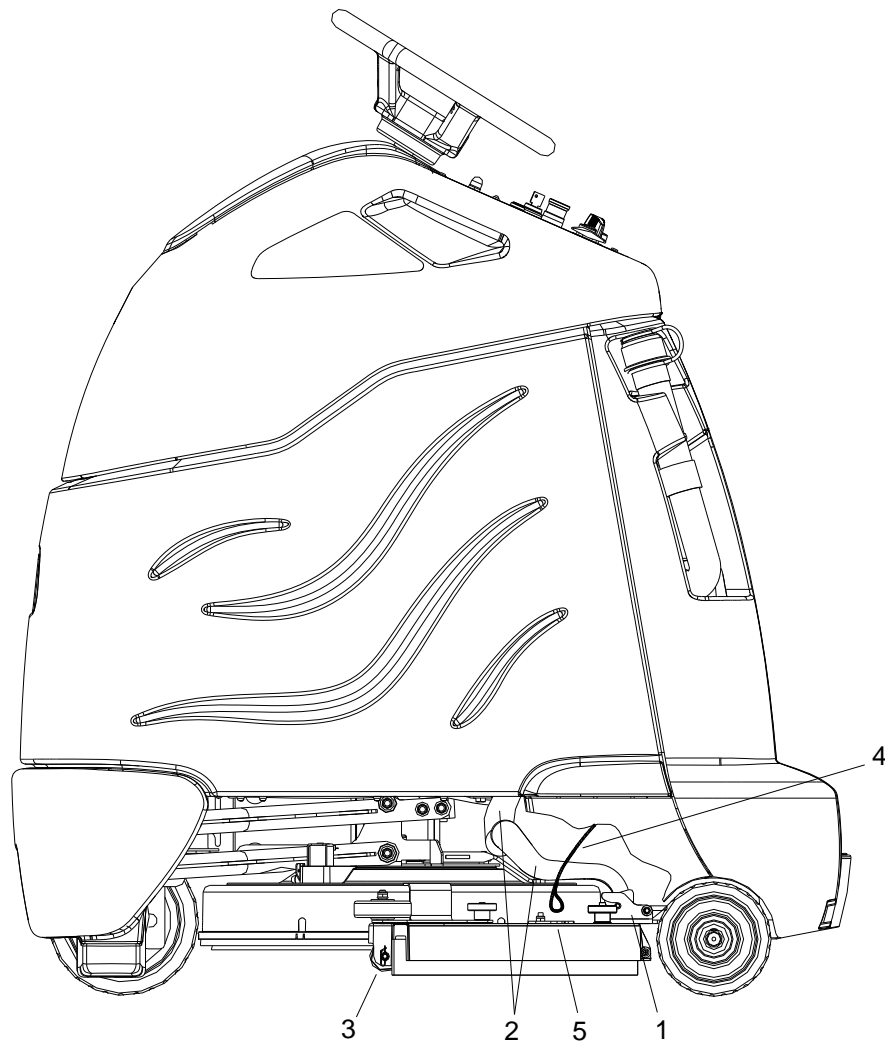

1. **Squeegee Latch**
2. **Squeegee Hose and Tube**
3. **Squeegee Wheels (3)**
4. **Double Scrub Support Cable**
5. **Double Scrub Cable Hook**

1. Squeegee Latch

The squeegee latch holds the squeegee in place.

2. Squeegee Hose and Tube

The squeegee hose and tube carry the recovered solution to the recovery tank.

3. Squeegee Wheels

The three squeegee wheels support the squeegee at the correct height and angle so that no adjustment is required.

4. Double Scrub Support Cable

The double scrub support cables retain the deck in the double scrub position.

5. Double Scrub Cable Hook

The double scrub cable hook is the connection point for the double scrub support cable. Since the squeegee is raised and lowered by the scrub deck, the double scrub position is set manually.

Machine Operation

Pre-Run Machine Inspection

Do a pre-run inspection to find possible problems that could cause poor performance or lost time from breakdown. Follow the same procedure each time to avoid missing steps.

NOTE: See maintenance section for pre-run machine inspection checklist items.

Starting Machine

NOTE: Perform pre-run machine check before operating machine.

FOR SAFETY: Before starting machine, make sure that all safety devices are in place and operating properly.

1. The operator should be on the pedal platform. The throttle pedal must be in the neutral position.
2. Turn the machine power on by turning key switch clockwise to the "ON" position.
3. Press the Drive Reset Directional Control Switch to reset and set the intended direction for travel.
4. Press lightly on the throttle pedal with right foot. Emergency Stop Procedures Push in emergency stop button. This will also engage the parking brake and cause the machine to stop immediately.

Emergency Stop Procedure

Push in emergency stop button. This will also engage the parking brake and cause the machine to stop immediately.

Filling Solution Tank

FOR SAFETY: Before leaving or servicing machine; stop on level surface, turn off machine and remove key.

1. Turn the machine power off.
2. Tilt console forward. Push left or right fill port cover down.

3. Fill the solution tank with clean water, leaving enough room for the required amount of cleaning solution. The solution tank capacity filled to fill inlet is 10 gallons (38 liters). The water must not be hotter than 140° F (60°C) to prevent damage to the tank
4. Measure the chemical into the solution tank. Liquid chemicals should be added to the solution tank after filling with water. Dry chemicals should be thoroughly mixed before being added into solution tank. Commercially available, high alkaline floor cleaners, are suitable for use in the solution system.

NOTE: Read the chemical manufacturers recommended proportion instructions.

5. Close console and latch rear cover.

⚠ WARNING:

Flammable materials can cause an explosion or fire. Do not use flammable materials in the tanks.

Filling Solution Tank (Deluxe)

FOR SAFETY: Before leaving or servicing machine; stop on level surface, turn off machine and remove key.

1. Turn the machine power off.

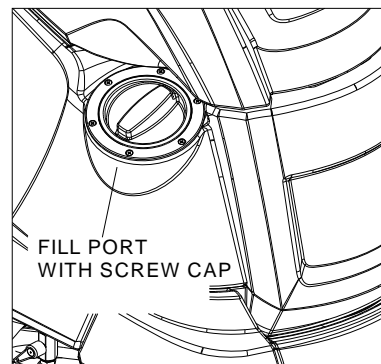

2. Using fill port, fill the solution tank with clean water, leaving enough room for the required amount of cleaning solution. The solution tank capacity filled to fill inlet is 10 gallons (38 liters). The water must not be hotter than 140° F (60°C) to prevent damage to the tank.

- Measure the chemical into the solution tank. Liquid chemicals should be added to the solution tank after filling with water. Dry chemicals should be thoroughly mixed before being added into solution tank. Commercially available, high alkaline floor cleaners, are suitable for use in the solution system.

Normal Scrubbing

Plan the scrubbing pattern in advance. The longest track is around the perimeter of the area to be cleaned. For efficient operation, the runs should be the longest possible without turning, stopping, or raising or lowering scrub deck/squeegee.

In order to achieve the best possible results, the area which is to be cleaned should be swept before scrubbing. Large debris, strings and wire must be removed to prevent being caught in brushes or squeegee.

If the machine is allowed to stand in neutral with the scrub deck down, the solutions flow stops and brush motor stops. If either forward or reverse travel is selected, the solution flow will continue in the same setting and the scrub brush motor will continue once movement of machine begins. Overlap the brush path and avoid transporting over previously cleaned areas.

To Begin Scrubbing

When operating the machine around people, pay close attention for unexpected movement. Use extra caution around children.

Flammable liquids and/or reactive metals can cause explosions or fire! Do not pick up.

- Stand on the operator platform. Throttle pedal must be in neutral position.
- Turn machine power on.
- Press the Drive Reset / Directional Control Switch, selecting the desired travel direction.
- Position the function control knob to the desired operation. The scrub deck and squeegee will lower, and the vacuum will turn on.
- Drive machine forward to begin scrubbing. The scrub brush motor will run and solution will flow when the throttle is depressed.

NOTE: Shut machine off immediately if water or foam is expelled from the machine. Solution flow is automatically shut off when brush motor stops. When brush motor is activated, flow automatically resumes.

INEFFICIENT SCRUBBING PATH

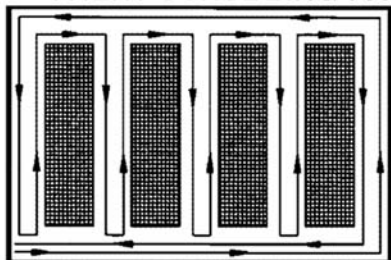

RECOMMENDED SCRUBBING PATH

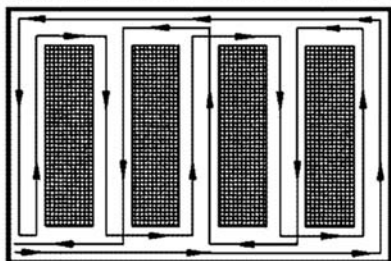

To Stop Scrubbing

1. Rotate the function knob to either transport position. The brush motor and vacuum will stop and the scrub deck will rise to the park position.
2. Allow the throttle pedal to return to neutral.
3. Turn machine power off.

NOTE: FOR SAFETY: Before leaving or servicing machine: stop on level surface, turn off machine and remove key.

Double Scrub

Floors which are heavily soiled or have thick accumulations of floor finish may not clean sufficiently with one pass. In these cases it will be necessary to double scrub.

Rotate the knob to the double scrub position.

Connect the Double Scrub Cables to the squeegee.

To support the squeegee off the floor for double scrub, pull the support cables down, one side at a time, and connect to the hook on the squeegee while lifting and tilting the squeegee upward.

To collect the solution and complete the Double Scrub operation, release both squeegee cable and turn the function knob to one of the normal scrubbing modes.

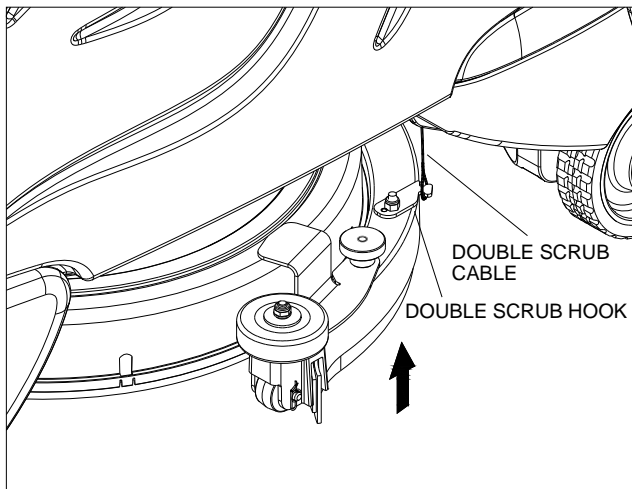

Emptying and Cleaning Tanks

1. Park the machine next to a floor drain. Drain hoses are at the rear of the machine.
2. Turn the machine power off.

Recovery Tank

1. Pull the recovery drain hose from the mounting pocket. Lift cap, pinch hose then lower hose in direction of the drain. Do not stand in front of end of hose. Recovered solution will come out with force.
2. To flush the recovery tank, lift the control console to access the recovery tank. Do not use water hotter than 140°F (60°C) to clean tank. Damage may occur.
3. Clean debris from sight dome and cover surface.
4. Clean off the float shut-off screen and inspect for free movement of float.
5. Replace the drain cap and secure drain hose.
6. If machine is to be stored, tilt the recovery tank back and prop the console up, partially opening each.

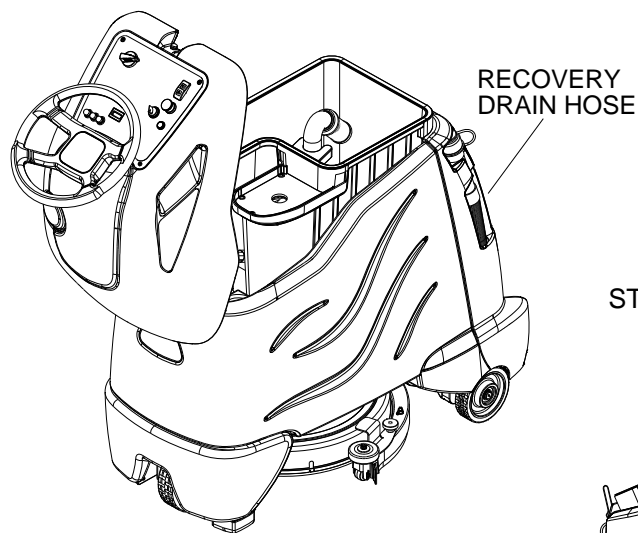

Solution Tank

1. Pull the solution drain hose from its mounting pocket. Lower hose in direction of drain.
2. Open the control console.
3. Flush the solution tank out with clean water and run several gallons of clean water through systems. Do not use water hotter than 140°F (60°C) to clean tank. Damage may occur.

Never allow solution to remain in tank. Damage to tank, seals and valves could occur.

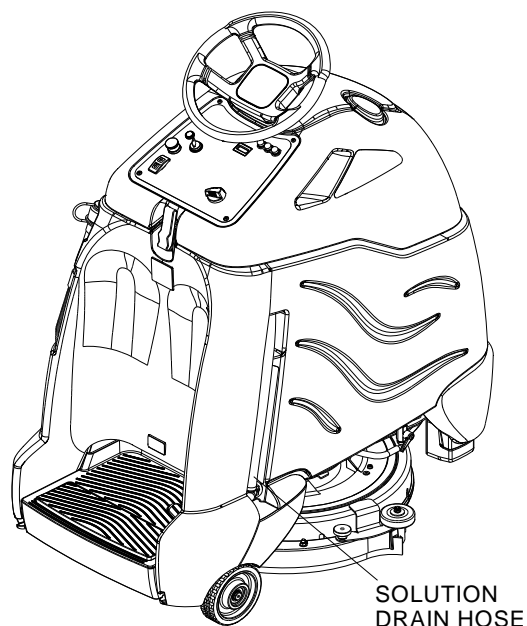

STORAGE POSITION

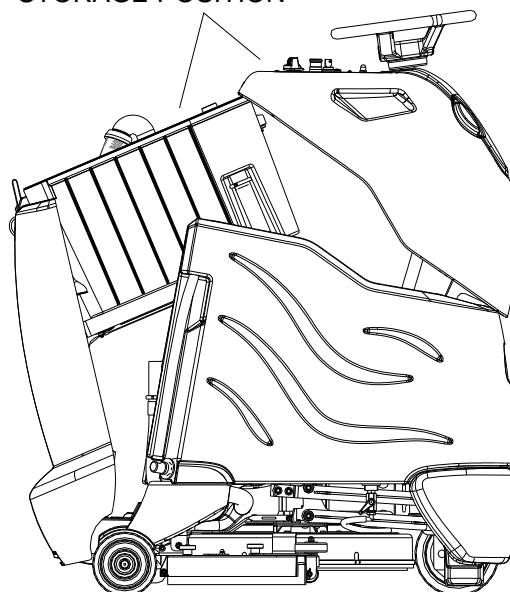

Service Schedule

MAINTENANCE	BEFORE EACH WORK PERIOD	AFTER EACH WORK PERIOD	50 HRS	100 HRS	200 HRS
Check water level of batteries after charging; add distilled water if necessary. (Wet cell only)	*				
Visually check for damaged or worn tires.	*				
Check brush or pad for proper installation.	*				
Check vacuum hose connections.	*				
Check that squeegee is securely attached.	*				
Check for securely attached drain hoses, plug and cap.	*				
Check pedal, brake and steering for proper operation.	*				
Clean out recovery tank.		*			
Clean and inspect float shutoff.		*			
Clean out solution tank.		*			
Clean and inspect solution filter strainer.		*			
Run vacuum motor to dry.		*			
Clean brush or pad and check wear.		*			
Clean squeegee blades and check wear.		*			
Clean outside of tanks, check for damage.		*			
Store with console cover propped open.		*			
Charge batteries if needed.		*			
Clean off top of batteries.			*		
Check battery cells with hydrometer. (Wet cell only)			*		
Inspect scrub deck skirt.			*		
Clean solution strainer inside tank.			*		
Check battery connections are tight.			*		
Clean battery cases and battery compartment.				*	
Check parking brake.					*
Clean pivot points on squeegee and scrub deck.					*
Check all motors for carbon brush wear.					*
Check motor commutators.					*
Check steering chain tension.					*
Check drive chain tension.					*

Batteries

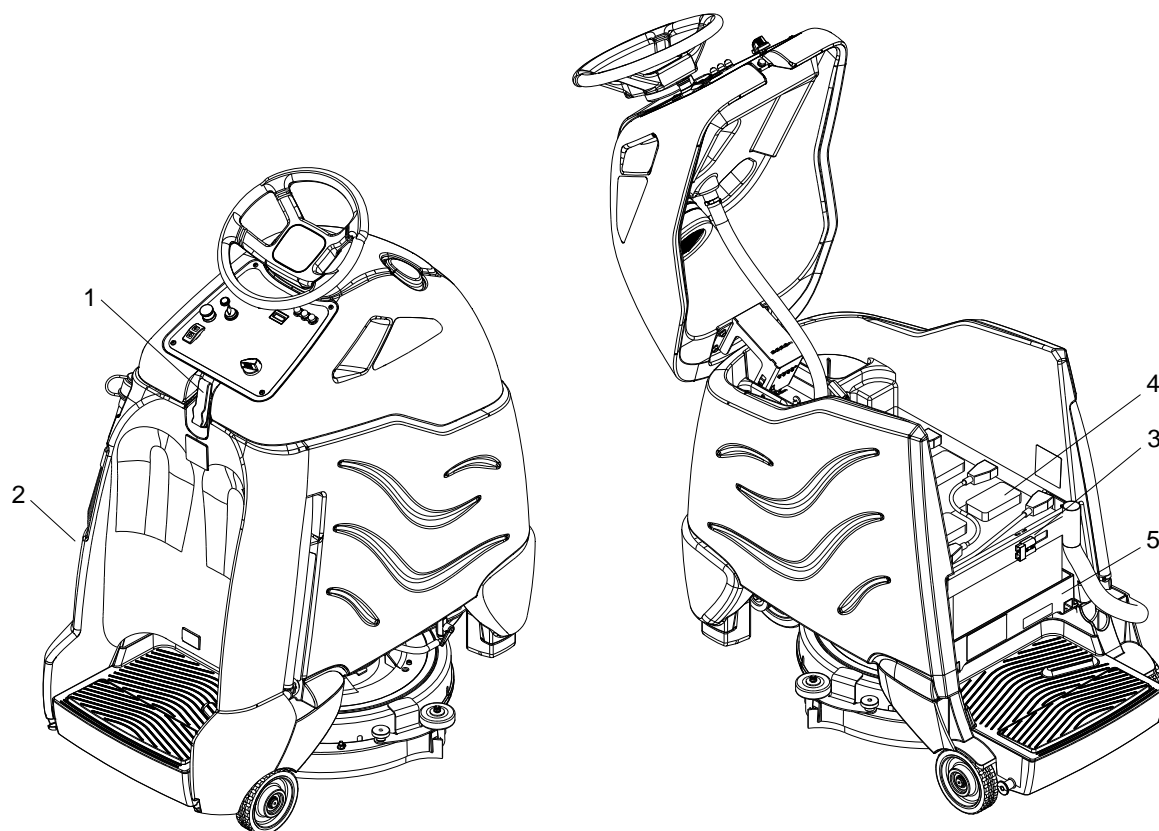

1. Cover Retainer Latch
2. Rear Cover
3. Battery Connector-Machine
4. Batteries
5. Battery Tray

Batteries (Wet Cell)

The batteries provide the power to operate the machine. The batteries require regular maintenance to keep them operating at peak efficiency.

The machine batteries will hold their charge for long periods of time, but they can only be charged a certain number of times. To get the greatest life from the batteries, charge them when their charge level reaches 25% of a full charge. Use a hydrometer to check the charge level.

Do not allow the batteries to remain in a discharged condition for any length of time. Never expose a discharged battery to temperatures below freezing. Discharged batteries will freeze causing cracked cases. Do not operate the machine if the batteries are in poor condition or if they have a charge level below 25% (specific gravity below 1.155).

Keep all metallic objects off the top of the batteries, as they may cause a short circuit. Replace worn or damaged cables and terminals.

Check the electrolyte level in each battery cell before and after charging the batteries. Never add acid to the batteries, use distilled water. Do not allow water level to fall below the battery plates. Portions of plates exposed to air will be destroyed. Do not overfill. Keep plugs firmly in place at all times.

⚠ WARNING:

Not all batteries require maintenance. AGM batteries are maintenance free. Do not attempt to remove sealed caps from AGM batteries. Warranty is void if caps are removed from AGM battery.

⚠ CAUTION:

When servicing machine, avoid contact with battery acid.

⚠ WARNING:

Batteries emit hydrogen gas. Explosion or fire can result. Keep sparks and open flame away. Keep covers open when charging.

⚠ WARNING:

Wear eye protection and protective clothing when working with batteries.

⚠ WARNING:

Charge batteries in a well ventilated area.

Battery Maintenance

1. When cleaning the batteries, use a solution of baking soda and water. Do not allow the cleaning fluid to enter the battery cells, electrolyte will be neutralized.
2. Maintain the proper electrolyte level in each battery cell. If a cell should accidentally overflow, clean immediately.
3. Wipe off the top of the batteries at least once a week.
4. Test battery condition with a hydrometer at least once a week.
5. Ensure that all connections are tight and all corrosion removed.
6. Every 4 to 6 months, remove the batteries from the machine and clean the battery cases and battery compartment.

Checking Battery Specific Gravity

Use a hydrometer to check the battery specific gravity.

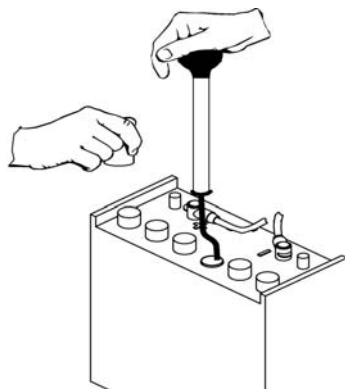

CHECKING GRAVITY

- a. Hydrometer Battery
- b. Battery

NOTE: Do not take readings immediately after adding distilled water, if the water and acid are not thoroughly mixed, the reading may not be accurate.

Check the hydrometer readings against this chart.

SPECIFIC GRAVITY @ 80° F (27°C)	BATTERY CONDITION
1.265	100% CHARGED
1.225	75% CHARGED
1.190	50% CHARGED
1.155	25% CHARGED
1.120	DISCHARGED

NOTE: If the readings are taken when the battery electrolyte is any temperature other than 80°F (27°C), the reading must be temperature corrected.

To find the corrected specific gravity reading when the temperature of the battery electrolyte is other than 80°F (27°C): Add (+) to the specific gravity reading 0.004 (4 points), for each 10°F (6°C) above 80° (27°C). Subtract (-) from the specific reading 0.004 (4 points), for each 10°F (6°C) below 80°F (27°C).

Charging Batteries

⚠ CAUTION:

When servicing machine, avoid contact with battery acid.

⚠ WARNING:

Batteries emit hydrogen gas. Explosion or fire can result. Keep sparks and open flame away. Keep covers open when charging.

⚠ WARNING:

Wear eye protection and protective clothing when working with batteries.

⚠ WARNING:

Charge batteries in a well ventilated area.

Use a 36 volt, 20 amp maximum output DC charger which will automatically shut off when the batteries are fully charged.

1. Stop the machine in a clean, well ventilated area next to the charger.
2. Turn "OFF" machine.

FOR SAFETY: Before leaving or servicing machine; stop on level surface, turn off machine and remove key.

3. Remove rear cover, unplug batteries from machine, unlatch battery tray and pull out to expose batteries.

⚠ WARNING:

Batteries emit hydrogen gas. Explosion or fire can result. Keep sparks and open flame away. Keep covers open when charging.

4. Check the electrolyte level in each battery cell. Before charging, add just enough distilled water to cover the plates. After charging is complete, add just enough distilled water to bring up the level to the indicator ring. If the water level is too high before charging, normal expansion rate of the electrolyte may cause an overflow resulting in a loss of battery acid balance and damage the machine.

Maintenance

5. Replace the battery caps, and leave them in place while charging.
6. Unplug the battery connector from the machine.

FOR SAFETY: When charging, connect the charger to the batteries before connecting the charger to the AC wall outlet. Never connect the charger to the AC wall outlet first. Hazardous sparks may result.

7. Plug the charger connector into the battery connector. Connect the charger AC plug to a wall outlet. The charger gauge should indicate that the batteries are charging.
8. When the batteries are fully charged, disconnect the charger from the AC wall outlet, then disconnect the charger from the batteries.
9. Connect the batteries to the machine connector.
10. Check the electrolyte level. It should be up to the indicator ring. If necessary, add distilled water.
11. Install the rear cover. Changing Batteries

Stop the machine in a clean area next to the charger. Turn off machine.

FOR SAFETY: Before leaving or servicing the machine; stop on level surface, turn off machine and remove key.

1. Open the console cover.
2. Tilt the rear cover/recovery tank back. The rear cover/recovery tank can also be removed for better access.
3. If equipped with optional on board charger, tilt charger mount to rear of machine.
4. Disconnect battery pack from machine.
5. Use the proper size open end wrench to disconnect main ground wire first and secure cable terminal away from batteries.

6. Disconnect main positive lead and secure cable terminals away from batteries.
7. Loosen both terminals on each jumper cable and remove one at a time.
8. Prepare a suitable site to place the batteries.

⚠ WARNING:

Attach suitable battery lifting device and lift batteries from the machine. Batteries are a potential environmental hazard. Consult your battery supplier for safe disposal methods.

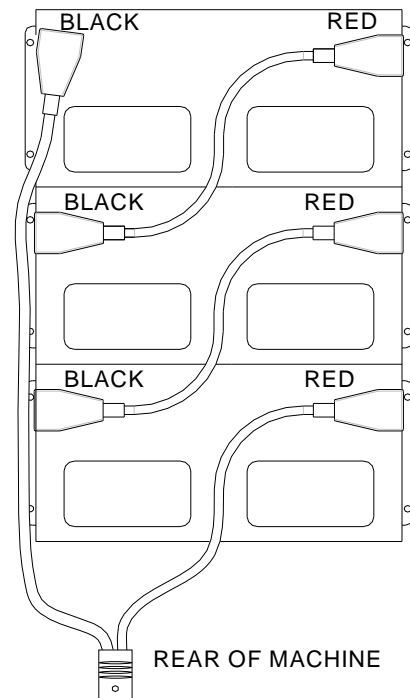

Battery Charger Programming

NOTE: For machines equipped with optional on-board charger. When replacing batteries, charger programming changes may be required. If replacing batteries with same type, (e.g. maintenance free batteries with maintenance free) no programming is required. When batteries with different type (e.g. maintenance free with wet cell), programming changes are required. Failure to make programming changes may lead to reduced battery life.

Switching From Wet Cell to Maintenance Free Batteries

Program charger from normal mode (red LED flashes) to alternate mode (All LED's flash):

1. Disconnect battery charger from outlet.
2. Connect (+) wire from EZlamp to (+) charger battery cable.

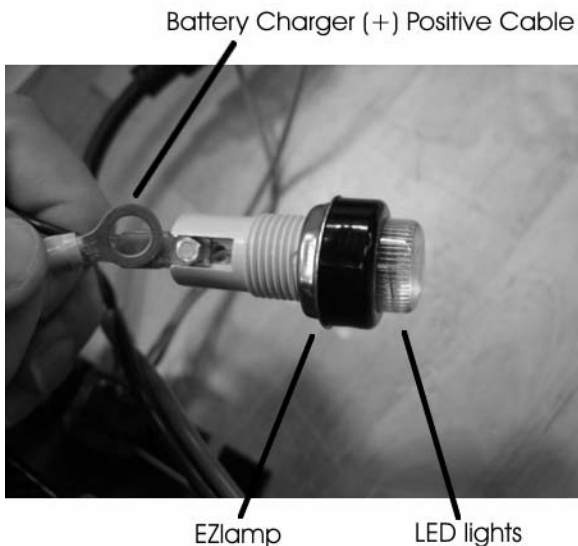

3. Connect AC cord to outlet. All LED's should be on.

NOTE: If all LED lights do not flash, repeat steps 1 and 2.

4. Wait 5 seconds, disconnect wires and unplug charger.
5. Programming is complete.

Switching From Maintenance Free to Wet Cell Batteries

Program charger from alternate mode (All LED's flash) to normal mode (red LED flashes):

1. Disconnect battery charger from outlet.
1. Connect (+) wire from EZlamp to (+) charger battery cable.
2. Connect AC cord to outlet. Red LED should be on.

NOTE: If Red LED light does not flash, repeat steps 1 and 2.

3. Wait 5 seconds, disconnect wires and unplug charger.
4. Programming is complete.

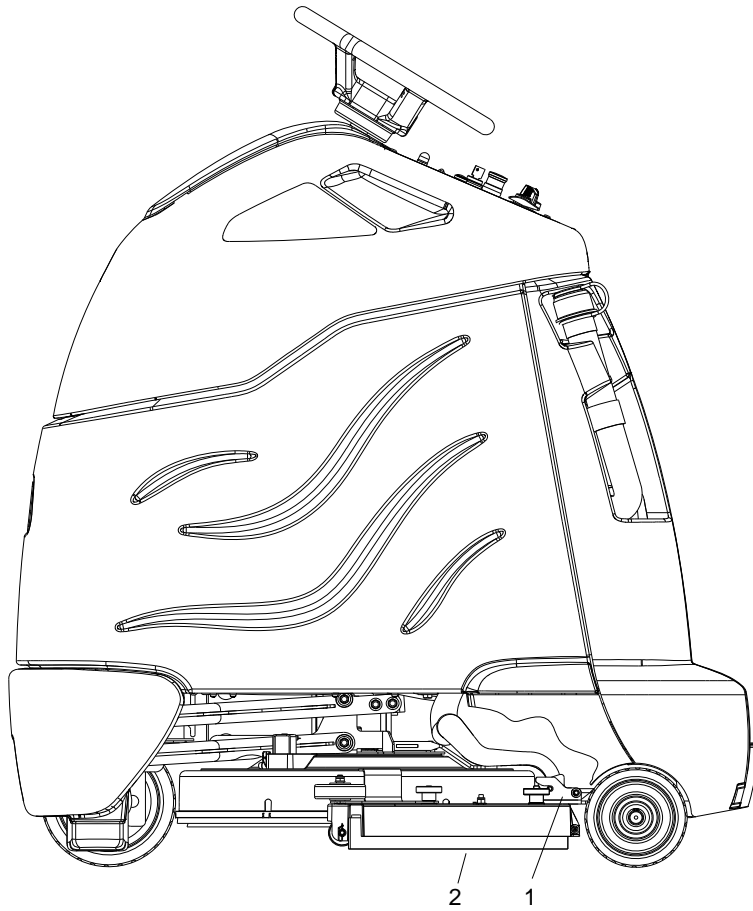

-
1. Squeegee Retainer Latch
 2. Squeegee

Squeegee Blades

The front squeegee blade allows solution to pass through channels in the blade into the squeegee assembly while maintaining vacuum to provide lift. The front blade has four wear surfaces and can be rotated for extended life. The front blade should not require regular replacement under normal use.

The rear blade wipes the floor to a near dry condition. It is important the rear blade be in good condition to properly do its job. As with the front, each squeegee blade assembly has four wear surfaces for extended service.

Check both the front and rear squeegee blades for damage and wear each day in the pre-run check. Change the front blade if it is torn or has an uneven edge. Change the rear blade if it is less than half the original thickness.

To Remove Squeegee Assembly

1. With the squeegee in the up position, turn key switch "OFF".
2. Disconnect vacuum hose from squeegee and squeeze the squeegee retaining latch..
3. Pull squeegee assembly from the squeegee arm.
4. Inspect or repair as necessary and reinstall.

To Replace or Rotate Squeegee Blades

1. With the squeegee in the up position, turn key switch "OFF".

FOR SAFETY: Before leaving or servicing machine; stop on level surface, turn off machine and remove key.

2. Remove the squeegee assembly from the machine.
3. Unscrew each of the four (4) knobs until they are nearly removed from the squeegee assembly. Grasp the squeegee assembly and push on the knobs to remove the blade retainer.

Remove the knobs and pull the blade retainer out. Rotate the squeegee blade to new edge position or replace as required. Each blade has four (4) new edge positions.

4. Pull the blades off the retainer.

To reinstall the blades, hook the blades over the pins on the retainer plate.

5. Lower the retainer with blades back in position in the squeegee assembly and install the knobs

Scrub Brush

There are different types of brushes available to cover applications from cleaning heavily soiled floors to polishing. A pad driver is also available to take advantage of the many cleaning pads on the market. Please refer to the following to assist in selecting the proper brush or pad for the work at hand.

Finished Floors

Polypropylene is a general-purpose scrub brush with stiff bristles. Polypropylene works well for maintaining grouted tile floors.

Nylon bristles are used in a variety of applications on coated or uncoated surfaces.

White Pads (Polishing) are used for dry polishing to achieve a high-gloss appearance, or surface washing on highly polished or burnished floors.

Red Pads (Buffing) are used for light-duty scrubbing. When used with a mild detergent they will provide surface cleaning without removing the finish.

Blue Pads (scrubbing) are used for heavy scrubbing and light top scrubbing. The blue pads remove black marks, stains and dirt. The blue pad may also remove some floor finish.

Black pads (top scrubbing) are used to remove ground in soil and the top layers of floor finish to prepare for recoating.

The scrub brushes should be checked before each days work for wire, string, wear and damage.

Scrub Deck

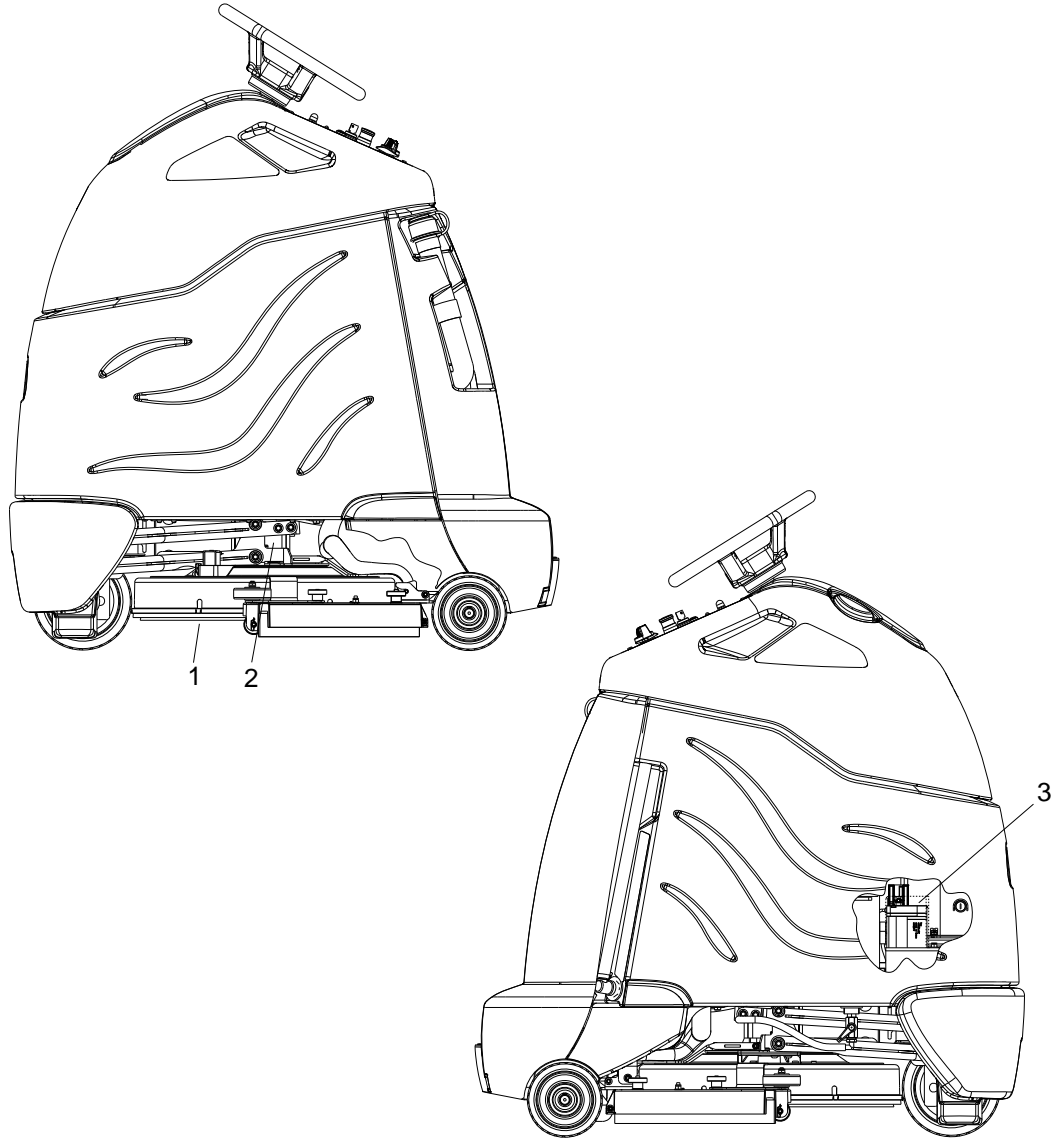

1. Scrub Deck Skirt
2. Scrub Brush Motor
3. Scrub Deck Lift Actuator

⚠ WARNING:

Do not use a pressure washer to clean around the brush motors. Use tap pressure only.

To Replace Scrub Brush Motor

With the scrub deck in the lowered position, disconnect brush motor wiring connector from harness.

1. Disconnect the two(2) connectors from solenoid valve.
2. Remove squeegee.
3. Remove front bumper.
4. Remove four (4) front bolts connecting deck lifting arms to front of machine.
5. Lift deck and side deck lift brackets off actuator lifting pin.
6. Slide deck out from under machine on right side, orientation is determined from operators view.
7. Remove brush/pad.
8. Remove driver.
9. Remove three (3) screws securing brush motor to deck.
10. Remove brush motor.
11. Reverse steps to install.

Scrub Deck Actuator Removal / Replacement

FOR SAFETY: Before leaving or servicing machine, stop on a level surface. Turn off machine.

1. Support deck under pad driver so that actuator pins can be removed.
2. Remove bumper screws (2).
3. Remove front battery.
4. Pull steering shaft.
5. Disconnect actuator from wiring harness.
6. From the underside of the machine, remove lower lifting pin from actuator.
7. Remove clevis pin from actuator upper bracket.
8. Lift actuator upward and free from machine.
9. Reverse steps to install.

Circuit Protection

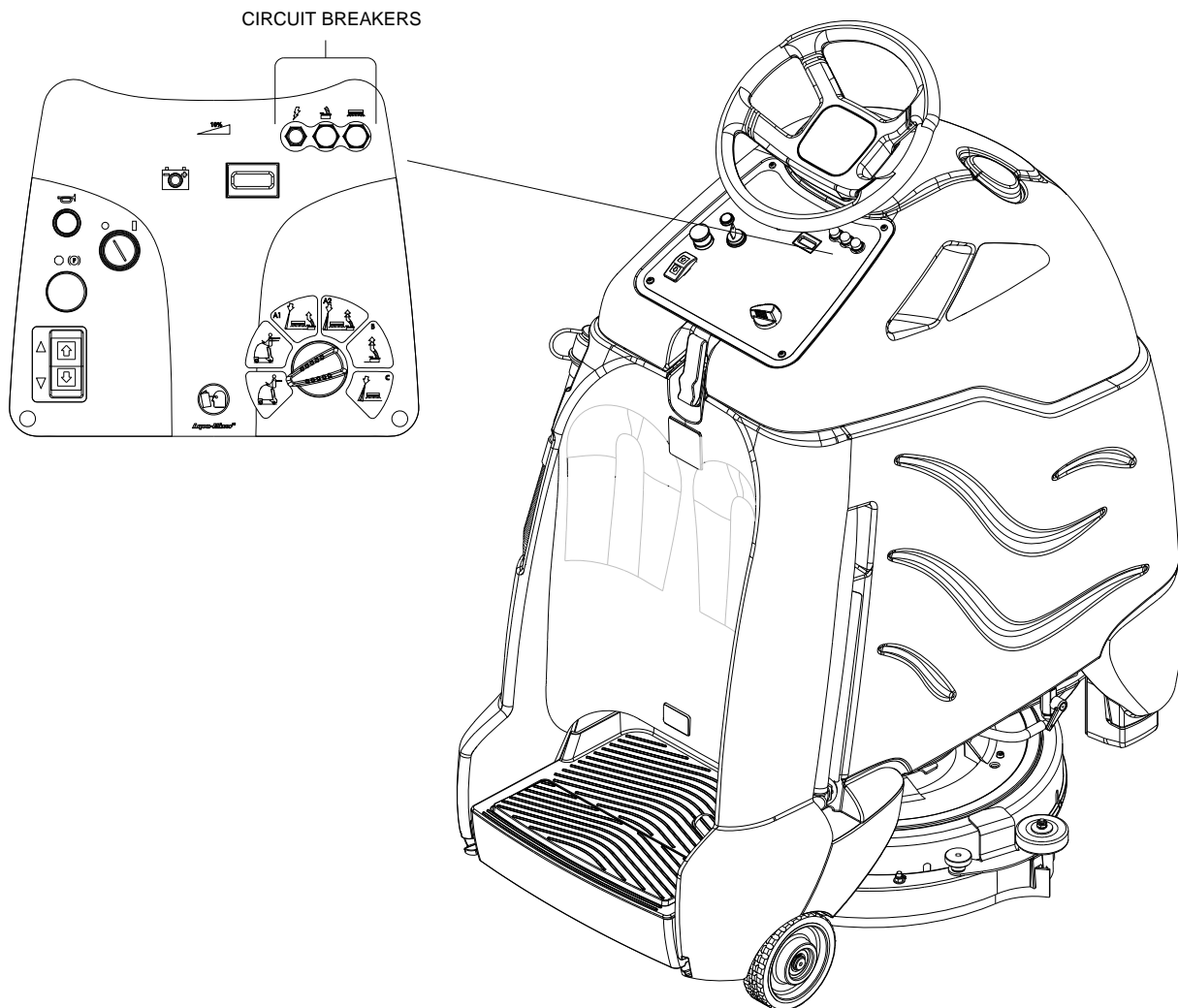

Circuit Breakers

Circuit breakers interrupt the flow of power in the event of an electrical overload. When a circuit breaker is tripped, reset it by pressing the exposed button. If a circuit breaker continues to trip, the cause of the electrical overload should be found and corrected.



1.5 Amp protects the brush deck lift actuator, horn & controller.



18 Amp protects the vacuum motor.

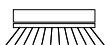

12 Amp protects the brush motor.

Solution

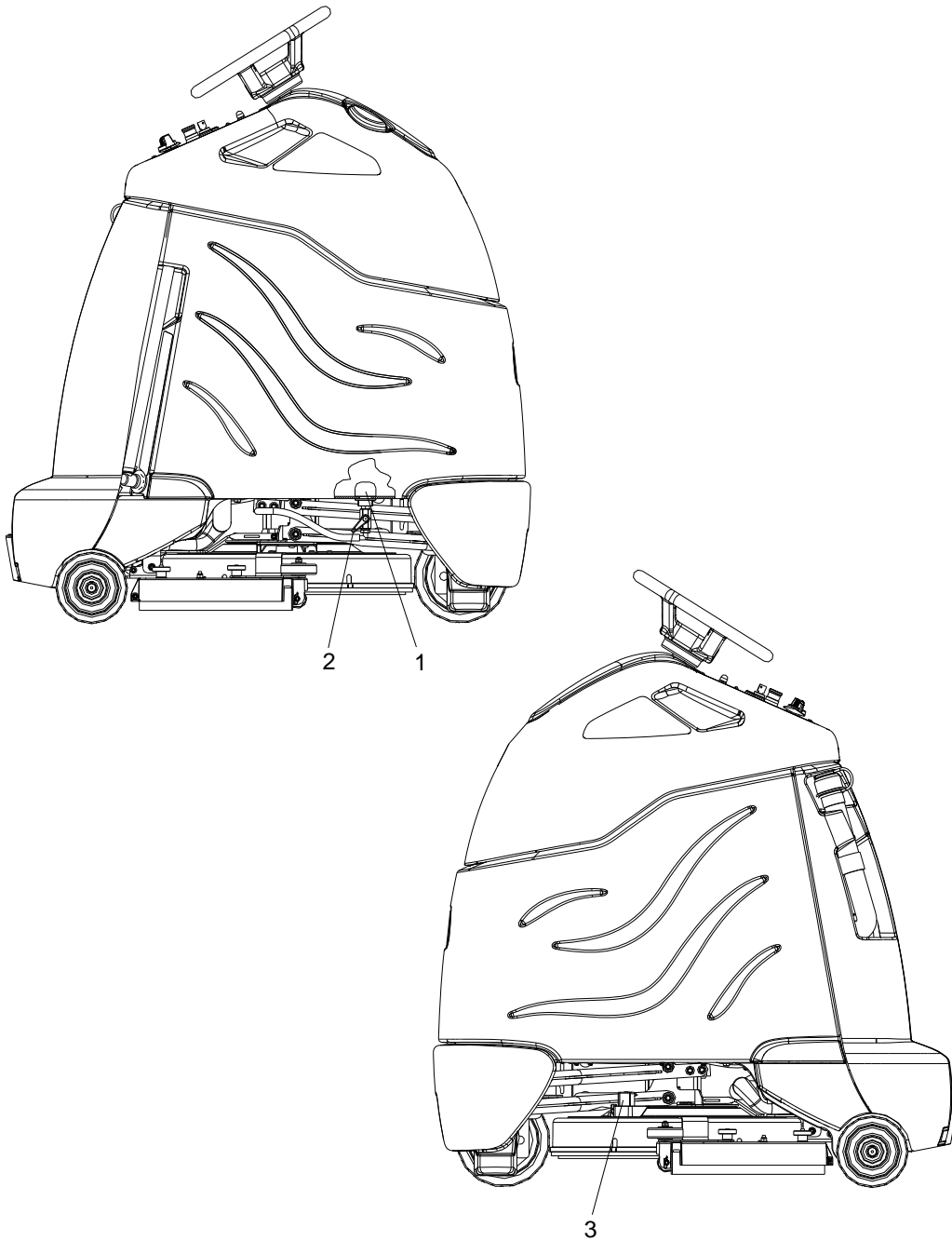

1. Solution Strainer-Coarse

2. Shut-off Valve

3. Solenoid Valve

1. SOLUTION STRAINER

Located in bottom of tank. The strainer protects the ball valve and solenoid valve from debris. If the ball valve and solenoid valve are not working, then check the strainer for debris.

Drain the solution tank.

Reach down to the strainer and remove debris. If the strainer can not be cleaned in place remove strainer.

To remove the strainer, rotate the strainer counterclockwise.

Clean out the debris from wire mesh and re-assemble

2. SHUT-OFF FLOW VALVE

Located below the solution tank on the right side. If no flow, check lever position.

Horizontal is half flow.

Down is maximum flow.

Up is no Flow.

If clogged, in the maximum position, unscrew fittings, inspect and clean if needed.

3. SOLENOID VALVE

The solenoid valve shuts off solution flow to scrub deck whenever scrubbing stops.

The solenoid valve is mounted on the front of the scrub deck, on left side.

Shut off manual water supply valve on right side of machine.

Disconnect the two (2) spade connections.

The solenoid valve snaps into place, rock the solenoid valve back and forth while lifting to free it.

Remove valve from supply hose.

Tank Assembly Removal

In order to access the frame or drive components, the entire tank/console cover assembly can be removed as a single unit.

Tank Removal:

1. Open the console cover.
2. Tilt the recovery tank back until it stops on the lanyard.
3. Remove the recovery tank vacuum hose from its connection at the rear cross member.
4. Tilt the recover tank slightly forward and disconnect the lanyard. Lean the recovery tank back until it contacts the floor. Lift the tank and back panel from the hinge pin and set aside.
5. Disconnect the squeegee vacuum hose from the connection at the rear cross member.
6. Grasp the lower end of the flexible steering shaft and pull it straight up until it is disengaged with the hex steering shaft. Place the loose end into one of the fill ports.
7. Remove the cover and gasket at the steering shaft area.
8. Disconnect four electrical plugs from the limit switches located between the steering shaft and the actuator. Do not pull on the wires to disconnect the plugs.
9. Disconnect the five electrical plugs located just forward of the battery tray. To disconnect, lift the plugs off of their mounting plate, locate and depress the lock tab and pull the connectors apart. Replace the lower half of the connectors on to the support plate after the tank assembly has been removed.
10. Remove the battery cable connection from the rear cross member.
11. Close the console cover.
12. Locate the solution solenoid valve on the left side of the scrub deck. Remove two electrical wires from the valve. The wires are interchangeable. Lift the valve out of its mount pocket and move the valve and connected hose over to the right side of the machine. It is not necessary to remove the valve or hose from the solution tank.
13. Remove the bumper. One mounting bolt per side is located just above the tip pads on the inside.
14. Remove 5 bolts holding the tank in place.
15. The tank assembly can now be lifted off the chassis and set aside.
16. Support the tank assembly so that the weight of it is not resting on the solution valve plumbing.
17. The lower half of the electrical connectors can now be easily placed on to their support plate.
18. Reverse the process for reassembly. Refer to the electrical diagrams for connection of the four limit switches. Use care not to bend the switch tabs.

Drive Unit Removal

1. Remove tank assembly.
2. Pull the brake and drive electrical connectors off of their support plate.
3. Remove the P-clamp holding the cable.
4. Lift the chain cover plate off of the motor.
5. Support the chassis on the tip pads so that the front wheel is 10 inches off the floor.
6. Locate and remove two mounting nuts and remove the drive unit from below.
7. To reinstall, reverse the process.
8. Note the small tab at the front of the drive unit frame should line-up with the notch in the mating plate.

Vacuum & Float Shutoff

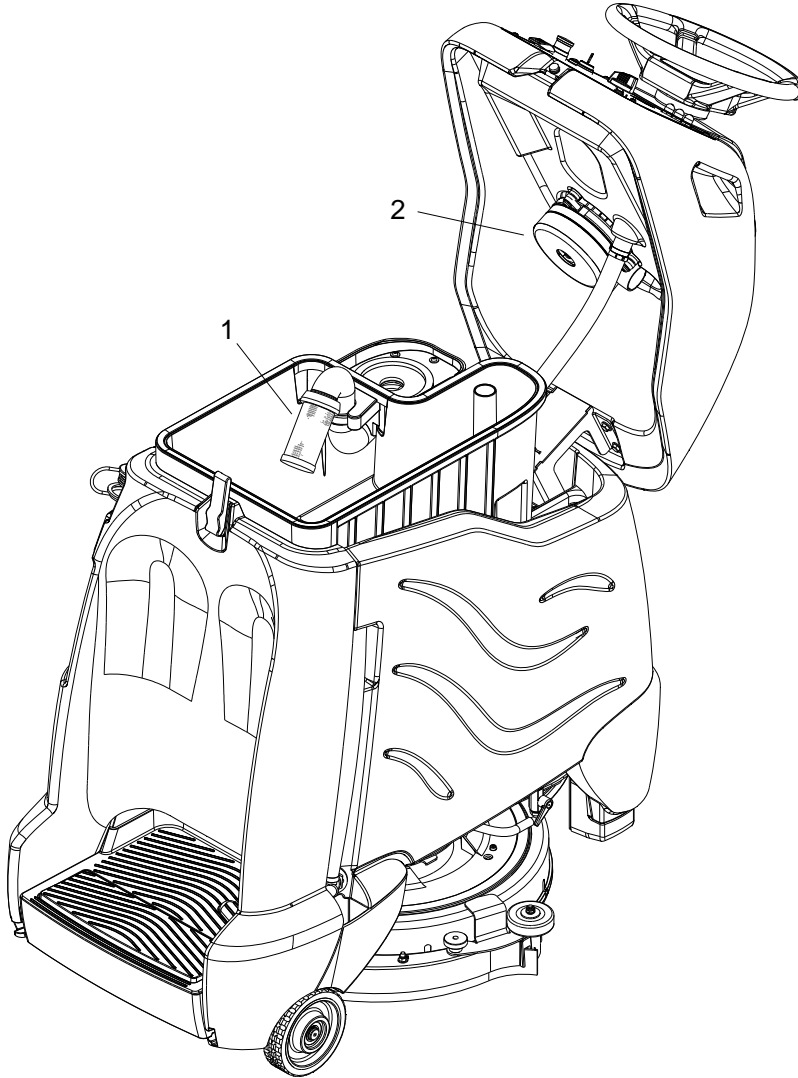

1. Recovery Tank Float Shut-off

2. Vacuum Motor

Recovery tank Float Shut-off

When water is no longer being vacuumed from the floor and the vacuum fan is operating, the ball float has engaged. The vacuum motor will not vacuum water with recovery tank full. The recovery tank must be drained.

1. The float shut-off screen can be cleaned in or out of the machine.
2. To clean the float shut-off while it is inside the machine wipe material off screen then rinse. Check that the ball is also clean and moves freely.
3. To remove the float shut-off, grasp the screen with one hand and the connected tube with the other. Tilt and pull the float screen assembly to pull it off the barb on the tube.
4. To install, place one hand on the tube, and then tilt and push the float screen assembly over the barb on the tube.

FOR SAFETY: before leaving or servicing machine, stop on a level surface, turn off machine and disconnect power.

To Repair or Replace Vacuum Motor

1. Open console.
2. Remove four (4) screws from top of control panel.
3. Tip control panel back from console to expose vacuum motor wires.
4. Disconnect electrical connector from the vacuum motor.
5. Remove three (3) screws that secure vacuum motor.
6. Reverse steps to install.

Vacuum Motor Carbon Brush Replacement

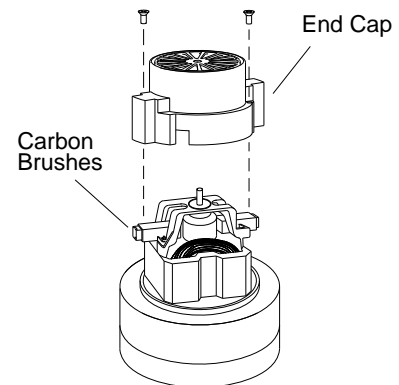

If armature commutator is grooved, extremely pitted or not concentric, the motor will need to be replaced or sent to a qualified service center.

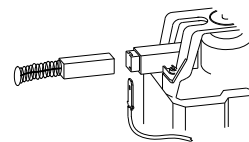

Important:

These brushes wear quicker as the length shortens due to increased heat. Spring inside brush housing will damage motor if brushes are allowed to wear away completely.

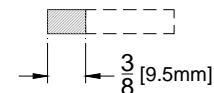

Periodically check the length of the carbon brushes. Replace both carbon brushes when either is less than 3/8" (9.5mm) long.

Drive Motor

Drive Motor Carbon Brush Replacement

⚠ WARNING:

Do not use a pressure washer to clean around the motors. Use tap pressure only.

FOR SAFETY: Before leaving or servicing machine, stop on a level surface, turn off machine and remove motor carbon brushes.

1. Open the console cover.
2. Tilt the recovery tank back until it stops on the lanyard.
3. Grasp the lower end of the flexible steering shaft and pull it straight up until it is disengaged with the hex steering shaft. Place the loose end into one of the fill ports.
4. Remove the cover and gasket at the steering shaft area.
5. Grasp the drive wheel by reaching under the front bumper and turn it to near the left steering stop.
6. The drive motor carbon brushes are located under screw caps. The caps are accessible by gently moving the harness aside.
7. Rotate the drive wheel to near the right hand stop to access the right side carbon brush.
8. Replace the gasket and cover, set the drive wheel straight ahead, set the steering wheel straight ahead, and gently align the steering shaft coupling and slide onto the lower shaft.
9. Slowly close the cover and make sure the shaft slides without binding.

Drive Chain Tension

The drive chain should deflect about 1/4 inch on either side of the loop when the opposite side is tight.

To adjust chain tension:

1. Remove bumper.
2. Loosen five (5) 10mm screws that hold the drive gear motor and slide the gear motor up until the chain tension is correct. Retighten the five (5) mounting blots.
3. Reinstall the bumper.

Transporting

Pushing Machine

This machine is equipped with a drive gear engagement/disengagement lever.

The brake automatically engages and keeps the machine from moving whenever the operator stops the machine.

The drive gear can be disengaged so the machine can be pushed or towed (slowly).

When the drive gear is disengaged the machine cannot be driven.

NOTE: Front bumper removed for clarity and to show access to lever.

Lever access

Turn wheel to left and reach up under bumper and steel bracket.

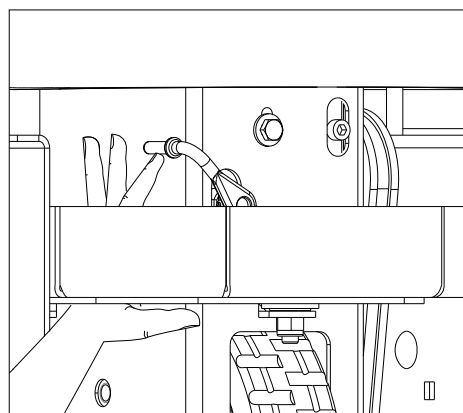

Drive gear engaged

Machine can be driven.

Rotate lever firmly in direction of arrow.

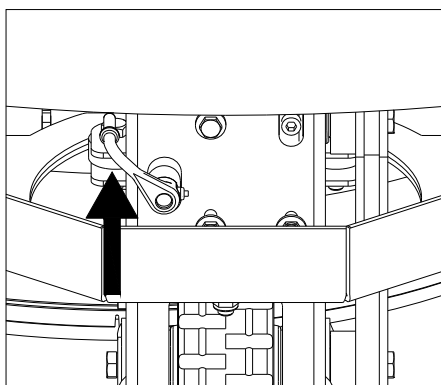
**Inclines**

When navigating an incline the machine may come to a stop. Turn the machine off. Wait 5 minutes and start the machine and proceed up the incline.

⚠ CAUTION:

Overheating may occur if you do not wait the full 5 minutes.

Drive gear disengaged

Machine can be pushed or towed (slowly).

When disengaged the machine rolls easily. Disengage on a level surface.

Rotate lever firmly in direction of arrow.

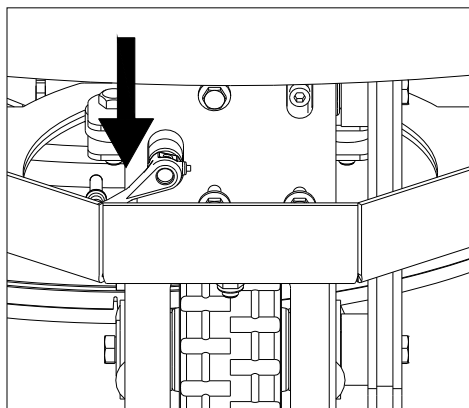

Preparation for Loading/Unloading Trailer

Before loading or unloading machine from trailer, remove squeegee and scrub brush (pad) to eliminate interference with ramp.

Scrub head must be in the up position before loading.

When transporting the machine on a trailer or in a truck, in addition to using tie-downs, be sure to block the tires to prevent the machine from rolling.

Machine Tie-Downs

There are two tie points located in front of the rear wheels on the frame, and a Tie-down wrap point on the recovery tank. Tie-down devices must be of the proper type and strength. The combined strength of all tie-downs must be strong enough to lift two times the weight of the machine. Tie-downs must be positioned to prevent the machine from moving forward, backward, or either side to side. Use all four corners of the machine with the tie-downs running out opposite directions. Tie-downs must be attached to the transporting vehicle securely.

Recommended Tie-Down Points

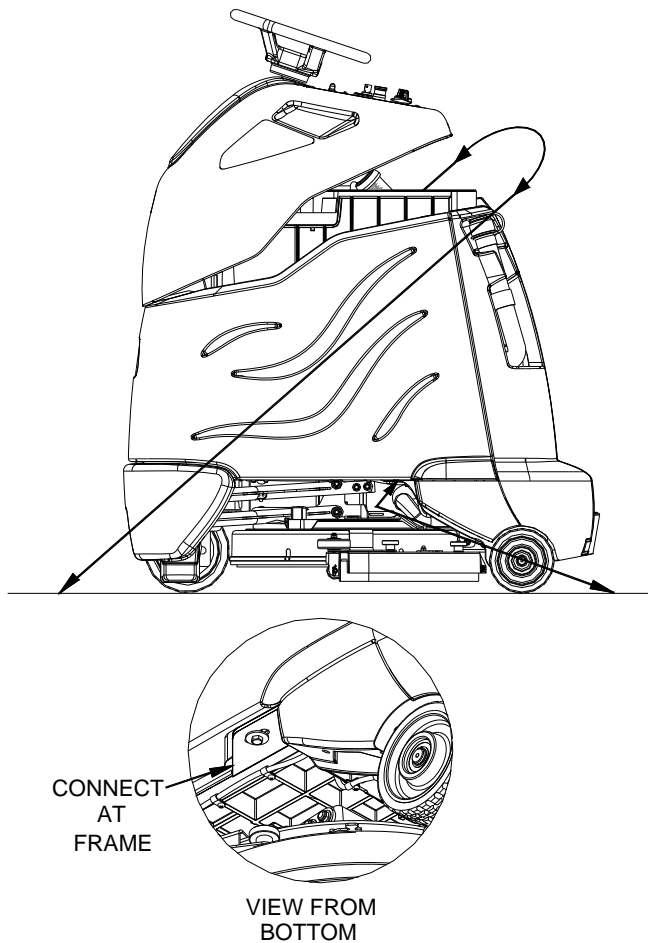

Machine Tie-Downs (Deluxe)

There are two tie points located in front of the rear wheels on the frame, one on the front bumper tie-down bar, and a Tie-down wrap point on the recovery tank. Tie-down devices must be of the proper type and strength. The combined strength of all tie-downs must be strong enough to lift two times the weight of the machine. Tie-downs must be positioned to prevent the machine from moving forward, backward, or either side to side. Use all four corners of the machine with the tie-downs running out opposite directions. Tie-downs must be attached to the transporting vehicle securely.

Recommended Tie-Down Points

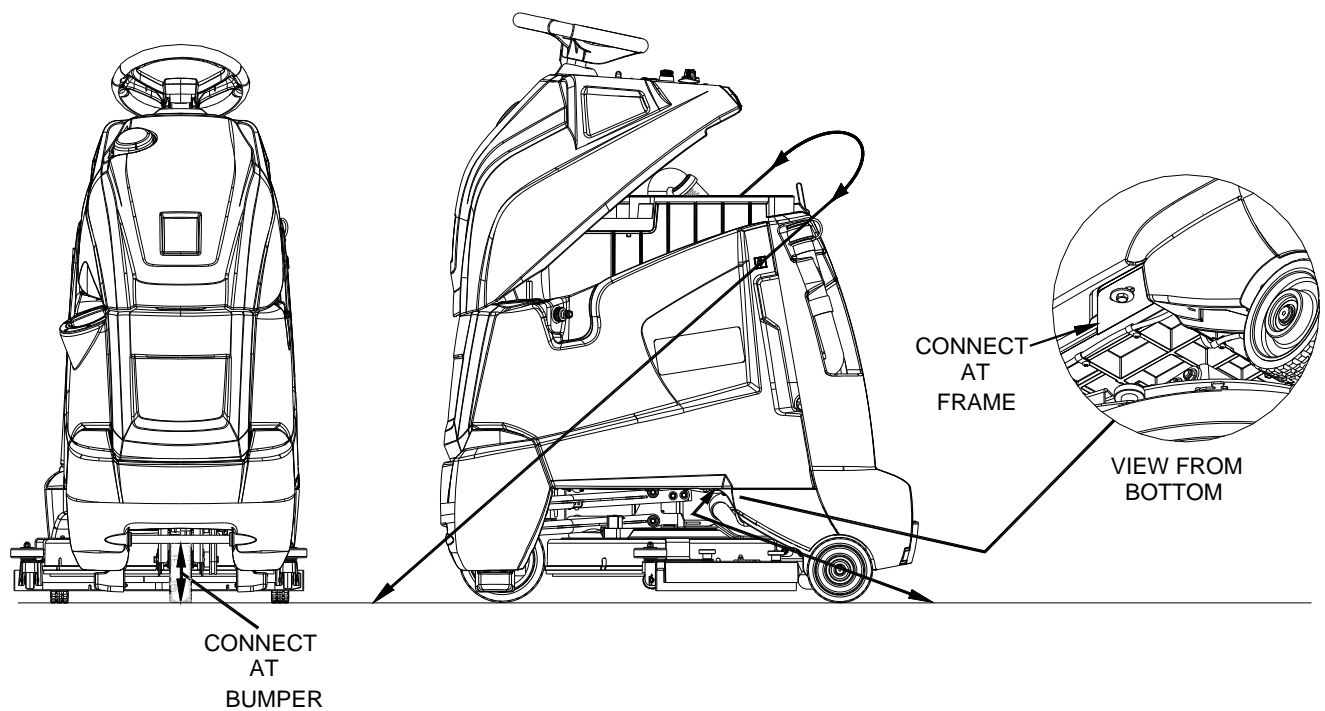

Troubleshooting

PROBLEM	CAUSE	SOLUTION
No machine function	Console lid is open	Close console lid
No power to machine	Battery disconnected	Check all battery cable connections
	Emergency shut-off activated	Reset
	Battery cables corroded	Clean connections
	Faulty key switch	Replace switch
	Batteries not plugged in	Plug batteries in
	On Board charger plugged in	Un-plug and stow cord
Little or no propel	Low battery charge	Charge batteries
	Tripped circuit breaker	Reset controller circuit breaker
	Controller protecting motor from overload	Controller limits motor amperage. Allow unit to cool down for several minutes.
	Machine is stalled against an obstacle (threshold, curb, etc.)	Remove obstacle or push machine away from obstacle
	Controller overheated	Allow cool down period
	Loose motor connection	Check wires and connections from controller to motor
	Faulty throttle circuit or potentiometer	Check wires and connections from and potentiometer resistance
	Drive Lever disengaged	Engage drive
Machine does not change speeds	Faulty speed control circuit or switch	Check wires & connections
Forward speed only	Faulty forward/reverse circuit	Check wires & connections
Reverse speed only		
Poor or no water pickup	Debris caught on squeegee	Remove debris
	Worn squeegee blades	Rotate or replace squeegee blades
	Vacuum hose clogged	Clear obstruction from hose
	Vacuum hose disconnected from squeegee or recovery tank	Reconnect vacuum hose
	Recovery tank float system dirty	Clean float system
	Recovery tank not sealed	Latch console cover Check or replace damaged gasket
	Vacuum circuit breaker tripped	Reset circuit breaker
	Float-ball shut-off engaged tank full	Empty recovery tank
	Foam filling recovery tank	Empty recovery tank. Use less or different detergent. Use defoamer
	Battery indicator light flashing	Battery needs charged
Controller is indicating a fault code		See fault code table

PROBLEM	CAUSE	SOLUTION
Vacuum motor does not run, or runs slowly	Faulty vacuum circuit or switch	Check wires & connections
	Worn vacuum motor brushes	Replace brushes, check commutator
	Vacuum circuit breaker tripped	Reset circuit breaker
Poor scrubbing performance	Debris caught in scrub brush	Remove debris
	Worn brush or pad	Replace brushes or pads
	Improper detergent, brush or pad used	Contact equipment or application specialists
	Low battery charge	Charge batteries
Little or no solution flow to the floor	Solution tank empty	Fill solution tank
	Solution strainer plugged	Clean solution strainer
	Solution system plumbing obstructed	Clear obstruction from plumbing
	Solution solenoid valve obstructed or stuck	Solution solenoid valve obstructed or stuck
	Solution metering valve is closed	Open metering valve
	Faulty solenoid	Check solenoid valve
	Faulty limit switches or connection	Check limit switches and connections
Brush motor does not run, or runs slowly	Circuit breaker tripped	Reset circuit breaker
	Low battery charge	Charge battery
	Faulty brush circuit or motor	Check wires, connections and motor
	Worn brush motor brushes	Replace brushes, check commutator
	Faulty limit switches or connection	Check limit switches and connections
Squeegee won't go down	Squeegee in double scrub mode	Release squeegee from double scrub mode
Deck won't go down	Actuator circuit breaker tripped	Reset actuator circuit breaker

Battery Discharge Indicator Troubleshooting

The battery indicator flashes when a problem occurs. The table below list solutions for the indicated problems.

Number of flashes	Problem	Solution
1	The battery needs charging, there is a bad connection to the battery or dependent on the programming, may indicate that the battery lockout function is active and the controller is in a restricted mode of operation. Check the connections to the battery.	If the connections are good, try charging the battery.
2	There is a bad connection to the drive motor.	Check all connections between the motor and the controller.
3	The drive motor has a short circuit to a battery connection.	Contact your service agent.
4	The battery charge level has fallen below the battery Lockout Level and the controller is inhibiting scrub motor function.	Charge the battery.
5	Not used.	-
6	The controller is being inhibited from driving, this may be because the battery charger is connected (on board charger only).	Disconnect battery charger.
7	A throttle fault is indicated.	Make sure that the throttle is in the rest position before switching on the machine.
8	A controller fault is indicated.	Make sure that all connections are secure.
9	The parking brake has a bad connection.	Check the parking brake and motor connections. Make sure the controller connections are secure.
10	An excessive voltage has been applied to the controller. This is usually caused by a poor battery connection.	Check the battery connections.
-	Blinks once every 5 seconds	Sleep mode, cycle key switch

Parts

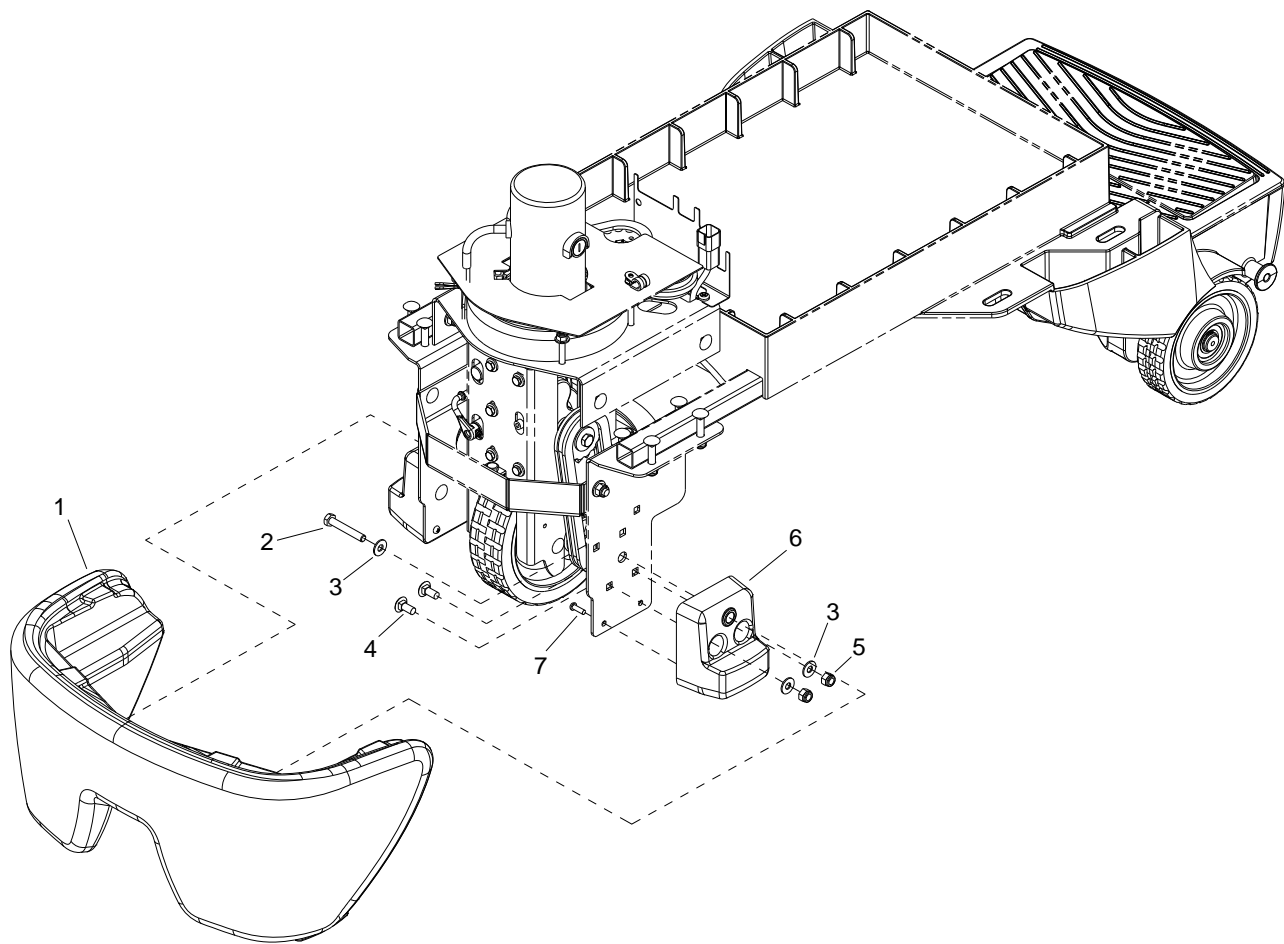

REF	PART NO.	PRV NO.	QTY	DESCRIPTION	SERIAL NO. FROM	NOTES
1	86342940	-	1	BUMPER, TRIM, GRAY		
2	86276980	70775	2	SCREW 5/16-18 X 2 HHCS SS		
3	86010670	87029	6	WASHER 5/16 FLAT SS		
4	86276070	70593	4	SCR, 5/16-18 X 3/4 CARRIAGE SS		
5	86270830	57023	4	NUT 5/16-18 HEX NYLOCK SS		
6	86323950	-	2	PAD, TIP		
7	86327510	-	4	SCR, KA50X16, PT OHS, WN1412, A2 SS		

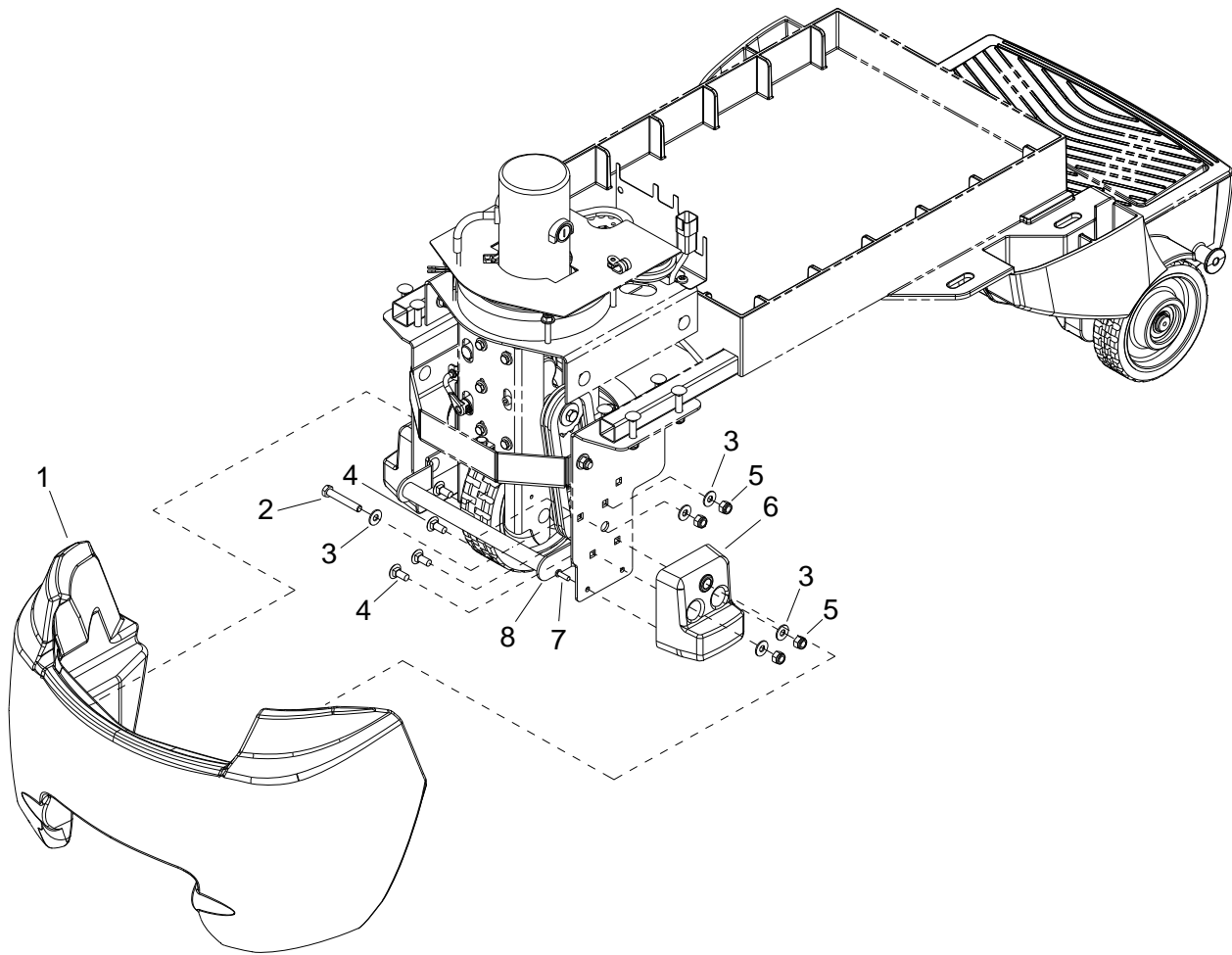

REF	PART NO.	PRV NO.	QTY	DESCRIPTION	SERIAL NO. FROM	NOTES
1	86342940	-	1	BUMPER, TRIM, CSX20		
2	86276980	70775	2	SCREW 5/16-18 X 2 HHCS SS		
3	86010670	87029	10	WASHER 5/16 FLAT SS		
4	86276070	70593	8	SCR, 5/16-18 X 3/4 CARRIAGE SS		
5	86270830	57023	8	NUT 5/16-18 HEX NYLOCK SS		
6	86323950	-	2	PAD, TIP		
7	86327510	-	4	SCR, KA50X16, PT OHS, WN1412, A2 SS		
8	86333910	-	1	BRACKET, TIE DOWN		

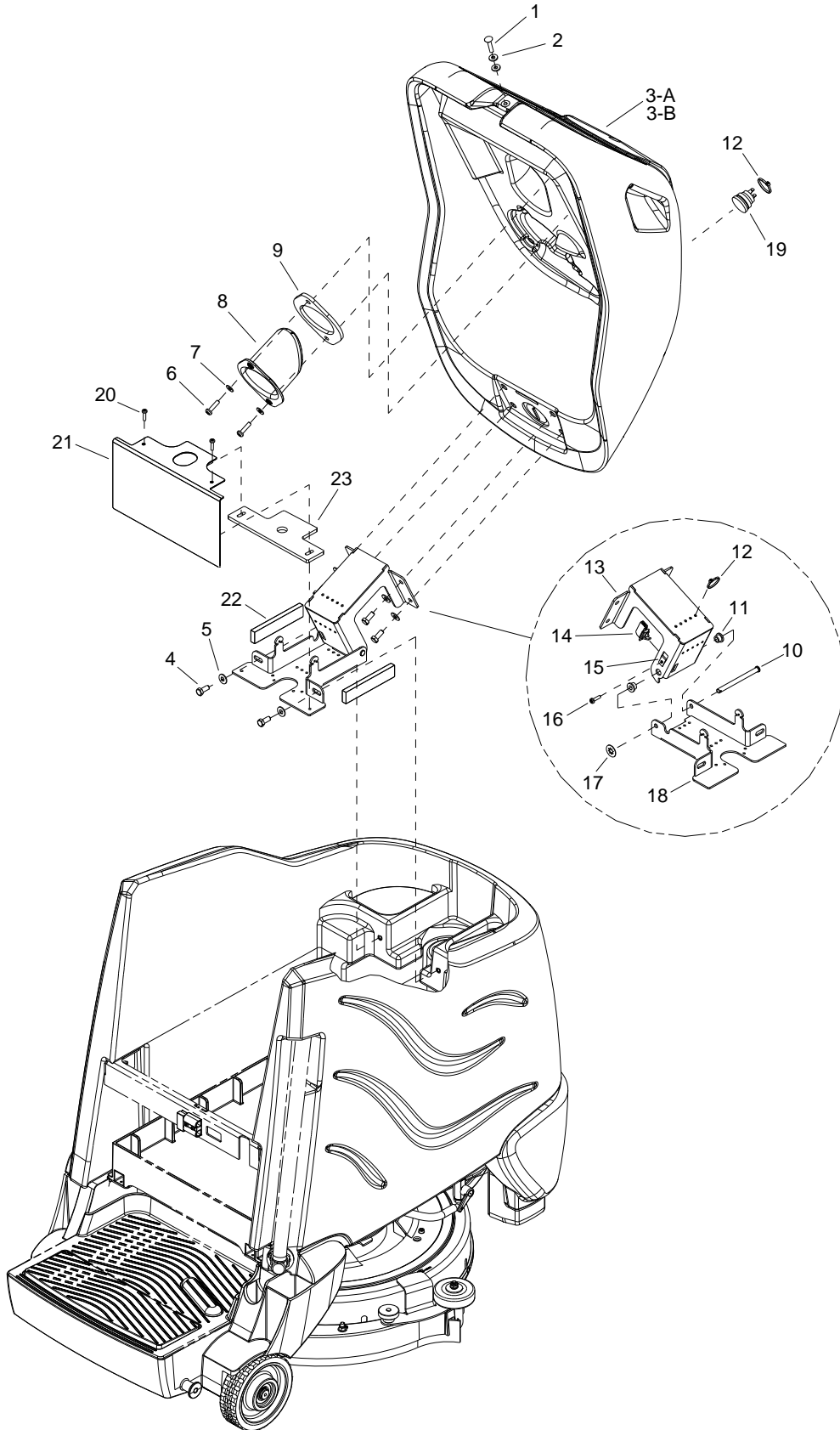

REF	PART NO.	PRV NO.	QTY	DESCRIPTION	SERIAL NO. FROM	NOTES
1	86276330	70634	1	SCR, 1/4-20 X 1.25 CARRIAGE BZ		
2	86279520	87172	2	WASHER, 1/4 ID FLAT BLK		
3A	86317960	-	1	CONSOLE, CS20		
3B	86342490	-	1	CONSOLE, CSX20		
4	86276780	70728	6	SCR, 5/16-18 X 3/4 HHCS SS		
5	86010670	87029	6	WASHER, 5/16 FLAT SS		
6	86006530	70057	2	SCREW 1/4-20 X 1 PPHMS SS		
7	86010630	87013	2	WASHER 1/4 ID X 5/8 OD SS		
8	86317980	-	1	DOME		
9	86327600	-	1	GASKET, DOME		
10	86326340	-	1	PIN, CLEVIS 5/16 X 4.0, PLTD		
11	86228990	09153	2	BEARING,FLNGD, .314ID X.502OD		
12	86264940	27051	6	CABLE TIE, 11.38" UL/CSA		
13	86326320	-	1	BRACKET, HINGE UPPER		
14	86327680	-	1	SWITCH, INTERLOCK		
15	86270860	57028	1	NUT, 10-24 U-TYPE SPEED		
16	86277110	70789	1	SCR, 10-24 X 3/4 PPHMS SS		
17	86328860	-	1	NUT, 5/16 PUSH-LOCK, PLTD		
18	86326330	-	1	BRACKET, HINGE LOWER		
19	86239720	41520	1	SP HORN, 108DB MINATURE W/RING		
20	86006800	70361	2	SCREW 10-32 X 1/2 PHTR PLT		
21	86332390	-	1	PLATE, COVER		
22	86332770	-	2	GASKET, HINGE BRACKET		
23	86332760	-	1	GASKET, STEERING SHAFT		

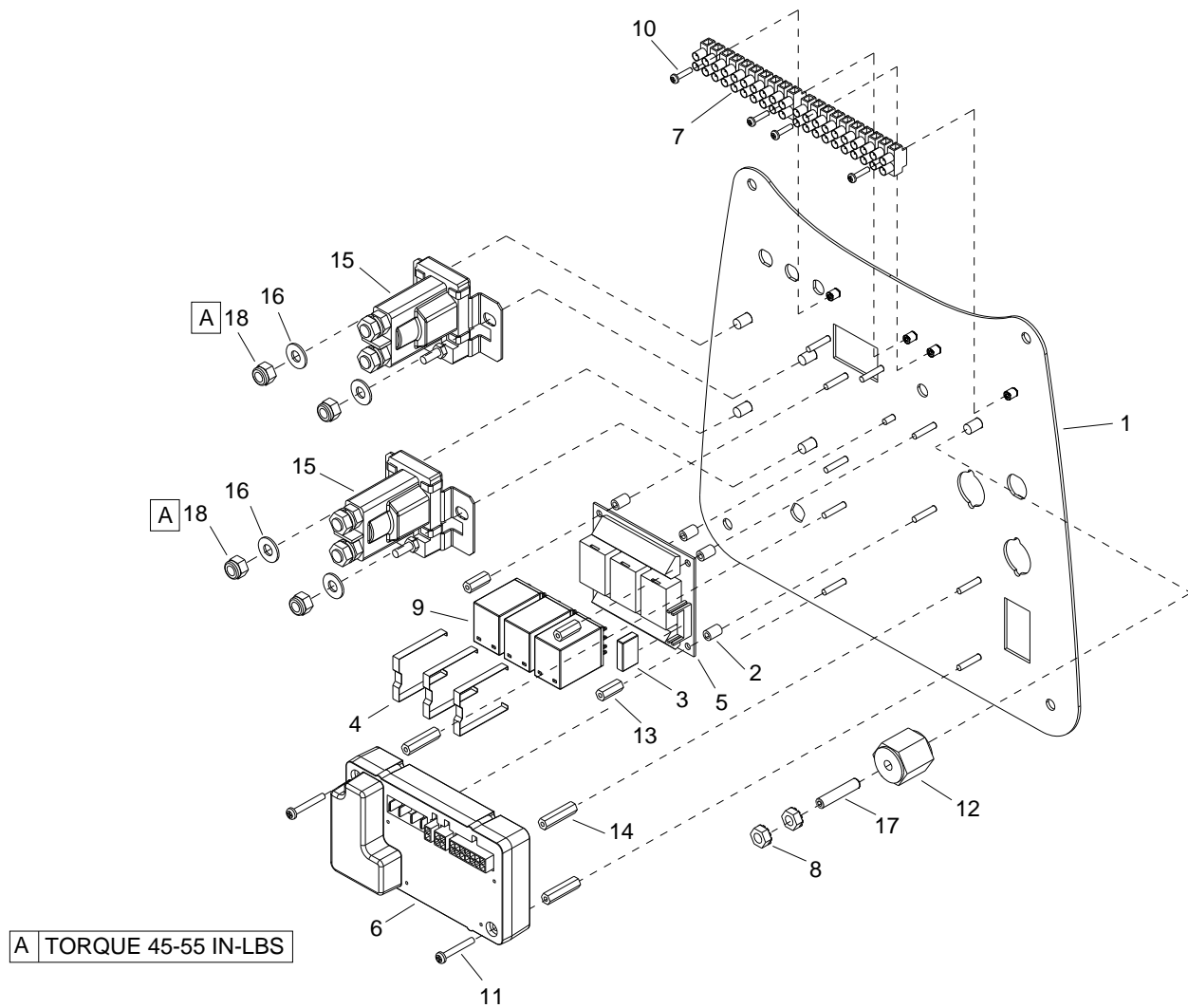

REF	PART NO.	PRV NO.	QTY	DESCRIPTION	SERIAL NO. FROM	NOTES
1	86339950	-	1	PANEL, CONTROL		
2	86337210	-	5	SPACER, .14ID X .25OD X .38, NYL		
3	86336110	-	1	RELAY, SPST-NO		
4	86336100	-	3	CLIP, RELAY		
5	86336090	-	1	CIRCUIT BOARD, 4 RELAY		
6	86329690	-	1	CONTROLLER, 20" SCRUB RIDE ON		
7	86326390	-	2	CONN, 8MM PITCH, 10 POSN		
8	86005710	57105	2	NUT, 1/4-20 HEX W/STAR		
9	86313900	-	3	RELAY, 5A, 24V, 4PDT		
10	86275260	70407	4	SCR, 4-40 X 1/2 PPHMS		
11	86274710	70261	2	SCR, 6-32 X 1.0 PPHMS		
12	86255910	73659	1	STANDOFF, 1/4-20 X 1.0 HEX INS		
13	86255900	73538	2	STANDOFF, 6-32 X 5/8 HEX NYL		
14	86255890	730164	4	STANDOFF, 1.0 L. 6-32		
15	86251360	67166	2	RELAY, 36VDC, 100A		
16	86010630	87013	4	WASHER, 1/4 X 5/8 FLAT SS		
17	86006850	70393	1	SCR, 1/4-20 X 1.25 SSSCU		
18	86005810	57245	4	NUT, 1/4-20 HEX NYLOCK SS		

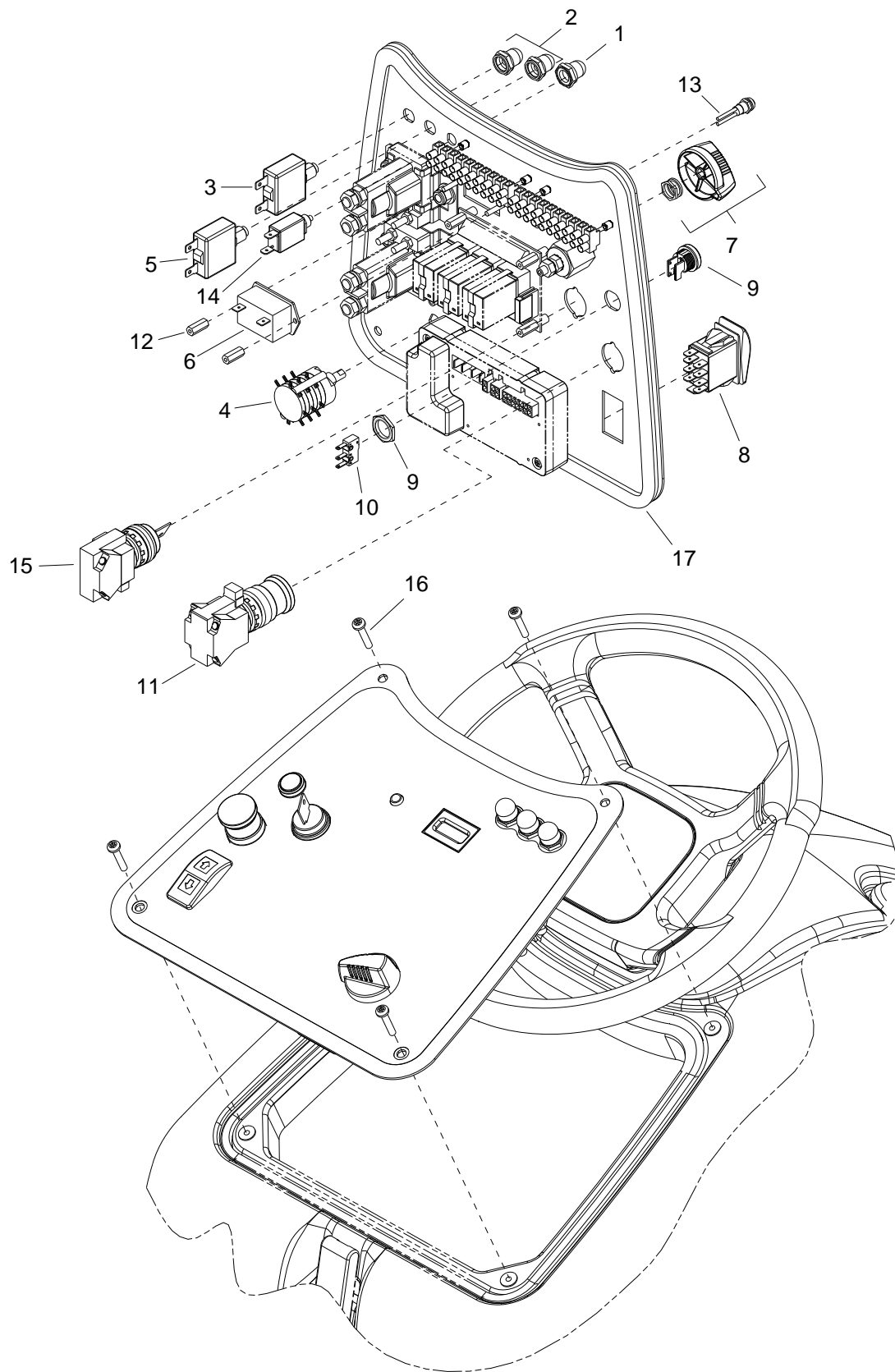

REF	PART NO.	PRV NO.	QTY	DESCRIPTION	SERIAL NO. FROM	NOTES
1	86002010		1	BOOT, 3/8 CIRCUIT BREAKER		
2	86332510	-	2	BOOT, SEAL PUSH BUTTON 11MM		
3	86328180	-	1	BREAKER, 12A, 250VAC, 32VDC		
4	98408880	-	1	KIT, CS20 ROTARY SWITCH		***
5	86316160	-	1	BREAKER, 18A, 250VAC, 32VDC		
6	86315470	-	1	METER, HOUR, LCD		
7	86314150	-	1	KNOB, SELECTOR		
8	86313950	-	1	SWITCH, SPDT 3 POSN MOM, ARROW		
9	86295200	-	1	ASM, BUTTON, BLACK, W/BEZEL		
10	86292780	-	1	SWITCH,MICRO		
11	86292590	-	1	SWITCH, E-STOP AKW CHARIOT		
12	86255900	73538	2	STANDOFF, 6-32 X 5/8 HEX NYL		
13	86246610	82521	1	LIGHT ASM, INDICATOR		***
14	86230140	14622	1	BREAKER, 1.5A THERMAL CIRCUIT		
15	86007170	72159	1	SWITCH, KEY 2 POSITION		
16	86329570	-	4	SCR, 10-32 X 1.0 TORX SS BLK PLTD		
17	86327830	-	1	GASKET, .188 X.31 X 41.0		

***86246610 AND ROTARY SWITCH ARE INCLUDED WITH CONTROL PANEL HARNESS, 98408880 IS FOR REPLACEMENT OF THE ROTARY SWITCH WITHOUT HARNESS.

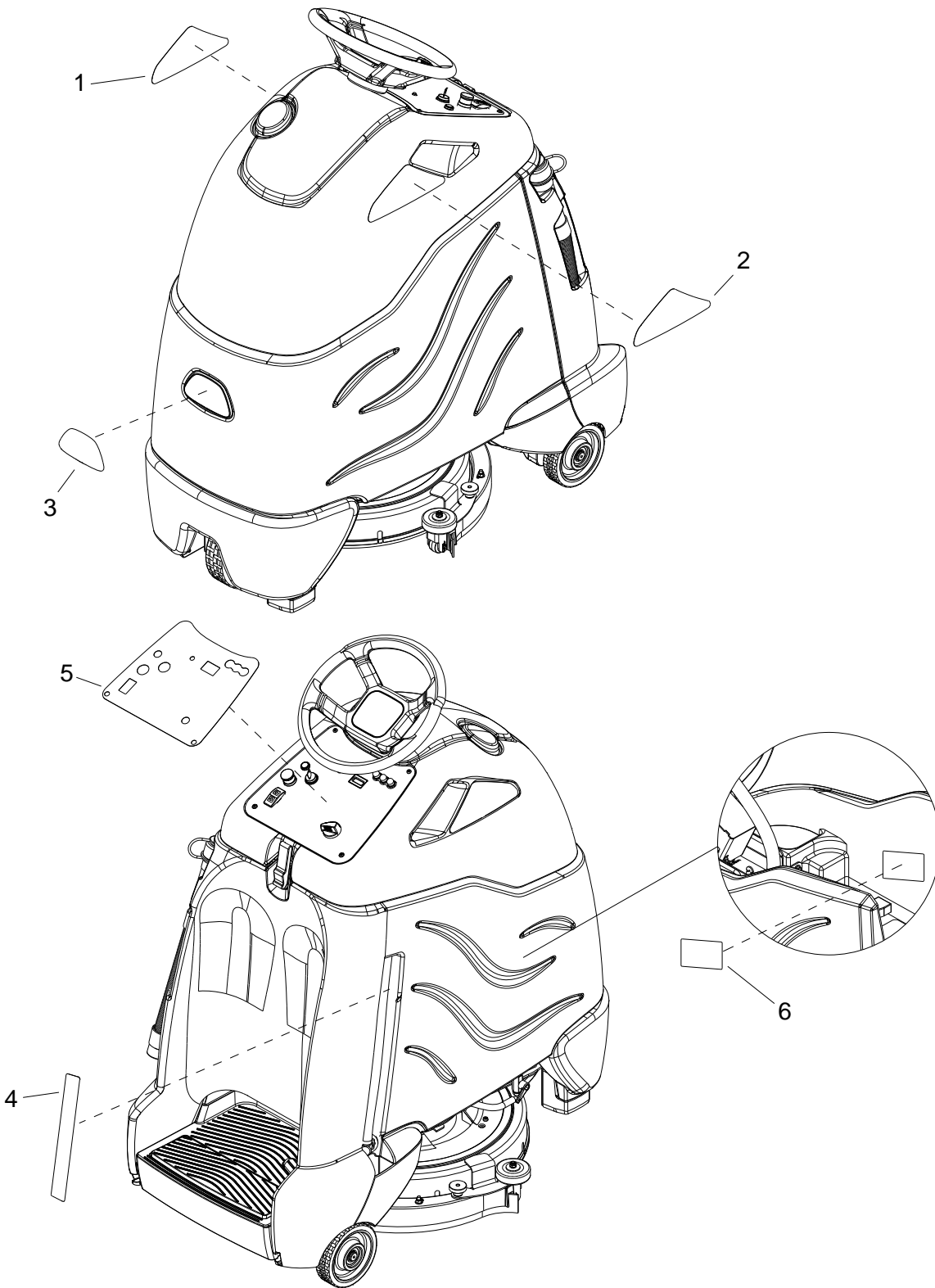

REF	PART NO.	PRV NO.	QTY	DESCRIPTION	SERIAL NO. FROM	NOTES
1	86328490	-	1	LABEL, RIGHT, iSCRUB 20		
2	86328500	-	1	LABEL, LEFT, iSCRUB 20		
3	86004970	50990	1	LABEL WINDSOR LOGO DOMED		
4	86328550	-	1	LABEL, SOLUTION LEVEL		
5	86326360	-	1	LABEL, CONTROL PANEL		
6	86335710	-	1	LABEL, BATTERY WIRING		

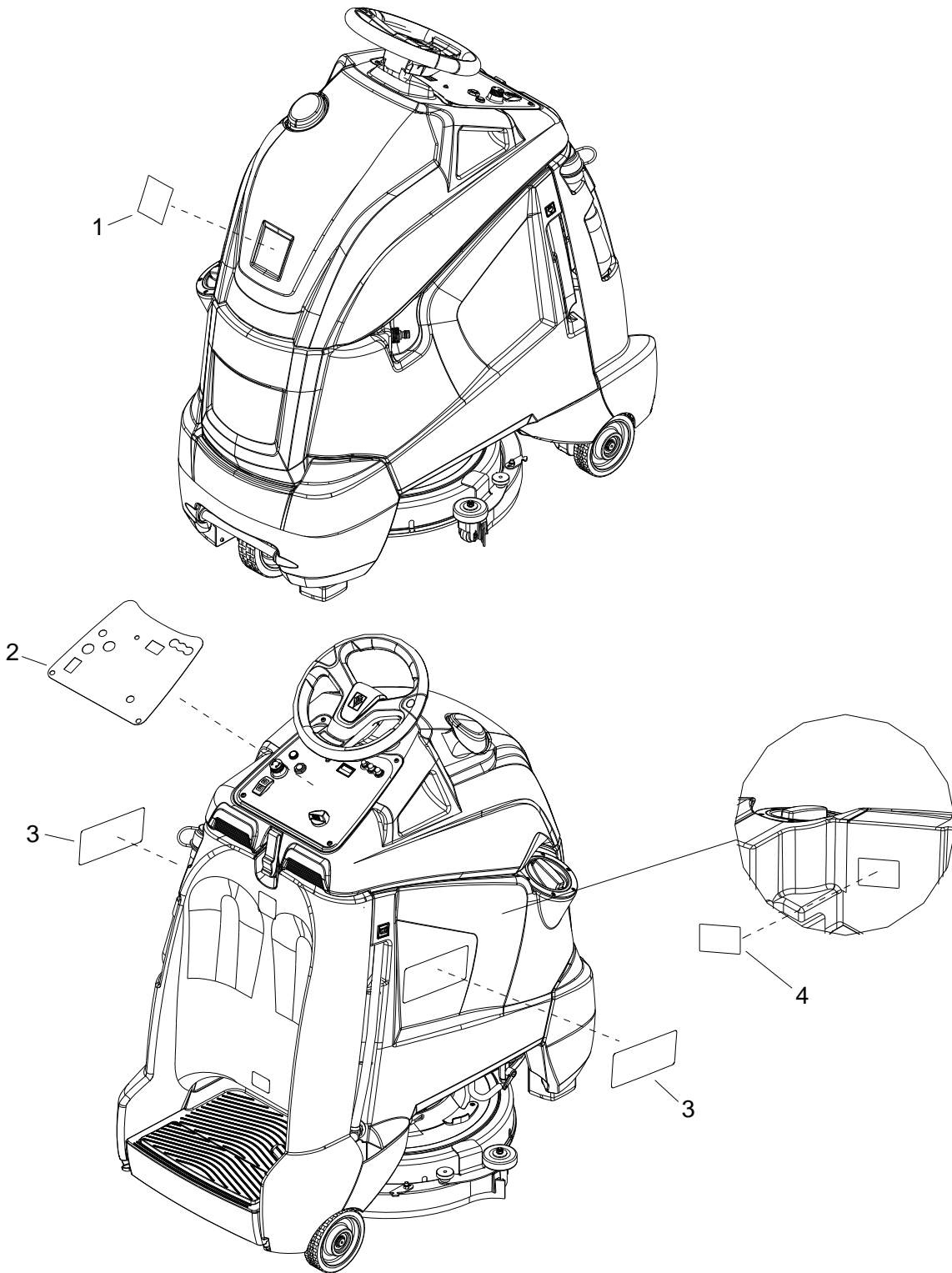

REF	PART NO.	PRV NO.	QTY	DESCRIPTION	SERIAL NO. FROM	NOTES
1	86342020	-	1	LABEL, WINDOSR DOMED LOGO		
2	86328550	-	1	LABEL, CONTROL PANEL		
3	86342000	-	2	LABEL, SIDE ISCRUB DLX		
4	86335710	-	1	LABEL, BATTERY WIRING		

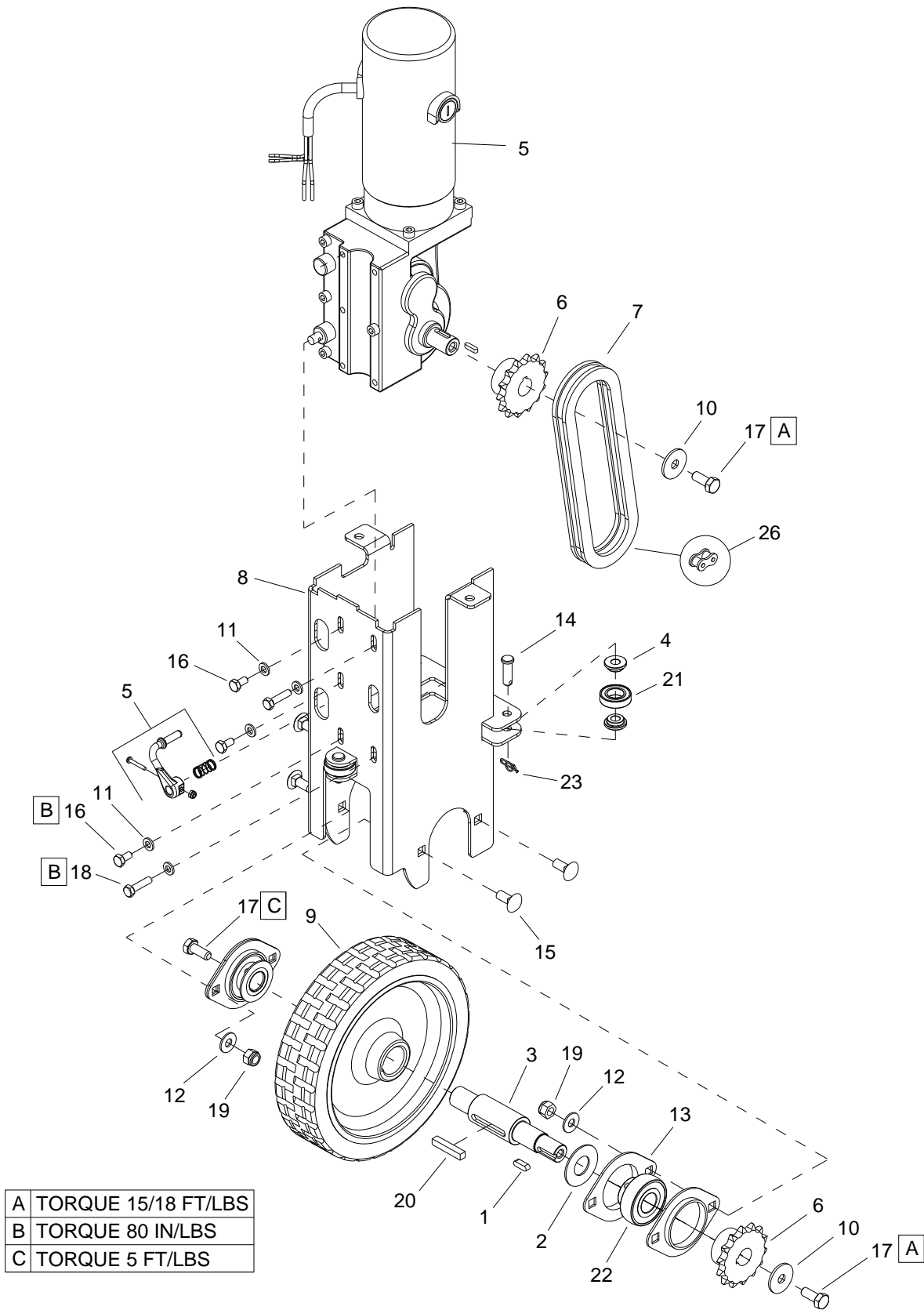

REF	PART NO.	PRV NO.	QTY	DESCRIPTION	SERIAL NO. FROM	NOTES
1	86326710	-	1	KEY, 5 X 5 X 16		
2	86321670	-	2	WASHER, WHEEL SPACER		
3	86319810	-	1	AXLE, DRIVE WHEEL		
4	86319670	-	6	SLEEVE, BEARING		
5	86319660	-	1	MOTOR, DRIVE WHEEL		
-	86331990	-	-	BRUSH SET, 8.631-966.0 DRIVE MTR		
-	98408960	-	-	BRAKE REPLACEMENT SMALL STAND ON		
6	86319650	-	2	SPROCKET, DRIVE, 14T		
7	86319640	-	1	CHAIN, ISO O8B, 12.7MM PITCH		
8	86319620	-	1	FRAME, LOWER DRIVE		
9	86316890	-	1	WHEEL, PU 200MM X 50MM		
10	86279630	87212	3	WASHER, .344IDX1.130ODX.09T PLT		
11	86270330	02-000066	5	FLATWASHER, 1/4		
12	86010670	87029	4	WASHER, 5/16 X 3/4 SS		
13	86008610	80595	4	FLANGE, BEARING PRESSED STEEL		
14	86272550	66485	3	PIN, CLEVIS, 5/16 X 1.00 PLTD		
15	86276070	70593	4	SCR, 5/16-18 X 3/4 CARRIAGE SS		
16	86275850	70552	3	SCR, M6 X 12 HHCS GR 8		
17	86136640	70262	3	SCR, M8 X 20 HHMS		
18	86277270	70821	2	SCR, M6 X 30MM HHMS		
19	86270830	57023	4	NUT, 5/16-18 HEX NYLOCK SS		
20	86219640	48108	1	KEY, 1/4 SQ. X 1.5		
21	86332380	-	3	ROLLER, 1.1 OD		
22	86001030	09148	2	BEARING, BALL 3/4 BORE SPHERED		
23	86008660	80605	3	COTTER 5/16" RING		
24	86333870	-	1	LEVER DRIVE ENGAGEMENT		DELUXE ONLY
25	86271240	57154	1	NUT, CAP 1/4 DIA RETAINING PLT		DELUXE ONLY
26	86232780	279001	-	CHAIN MASTER LINK 12.7MM		

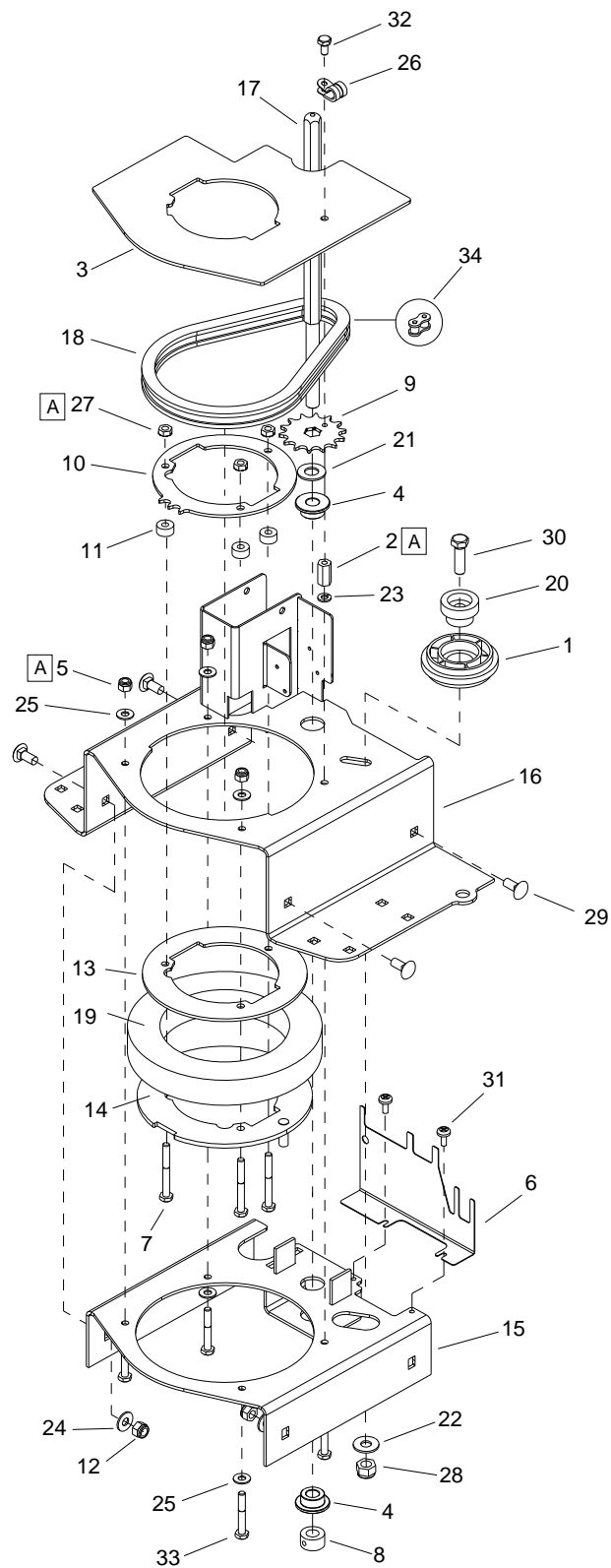

A TORQUE 78 IN/LBS

REF	PART NO.	PRV NO.	QTY	DESCRIPTION	SERIAL NO. FROM	NOTES
1	86330720	-	1	CHAIN TENSIONER		
2	86329350	-	1	NUT, 1/4-20 X 7/8 HEX COUPLING SS		
3	86329340	-	1	PLATE, CHAIN GUARD		
4	86328050	-	2	WASHER, SHOULDER.48ID X 1.25OD		
5	86005810	57245	3	NUT, 1/4-20 HEX NYLOCK SS		
6	86327110	-	1	BRACKET, CONNECTORS		
7	86273100	00-000004	3	SCR, 1/4-20X2-1/4 HXHD CAP		
8	86322060	-	1	COLLAR, 12MM ID		
9	86322050	-	1	SPROCKET, STEERING, 14T		
10	86322040	-	1	PLATE, CHAIN RING		
11	86322030	-	3	SPACER		
12	86270830	57023	7	NUT, 5/16-18 HEX NYLOCK SS		
13	86319740	-	1	PLATE, UPPER CLAMP		
14	86319680	-	1	PLATE, LOWER CLAMP		
15	86319610	-	1	BRACKET, BEARING CLAMP		
16	86319600	-	1	BRACKET, DRIVE MOUNT		
17	86319590	-	1	SHAFT, STEERING SPROCKET		
18	86319560	-	1	CHAIN, ISO O8B, 12.7MM PITCH		
19	86014440	-	1	BEARING, DRIVE		
20	86224270	730293	1	SLEEVE, CHAIN TENSIONER		
21	86259430	87485	1	WASHER, 12.5 ID X 26 OD X 2T FLAT		
22	86279510	87171	1	WASHER, 3/8 X 1 FLAT NP		
23	86010780	87162	1	WASHER, 1/4 SPLIT		
24	86010670	87029	4	WASHER, 5/16 X 3/4 SS		
25	86010630	87013	7	WASHER, 1/4 X 5/8 FLAT SS		
26	86233380	80886	1	CLAMP, 3/8 CUSHIONED		
27	86005710	57105	3	NUT, 1/4-20 HEX W/STAR		
28	86271930	57297	1	NUT, 3/8-16 HEX NYLOCK SS		
29	86276070	70593	4	SCR, 5/16-18 X 3/4 CARRIAGE SS		
30	86275190	70377	1	SCR, 3/8-16 X 1.25 HHCS SS		
31	86006800	70361	2	SCR, 10-32 X 1/2 PHTR PLT		
32	86274760	70271	1	SCR, 1/4-20 X 1/2 HHCS		
33	86274150	70105	4	SCR, 1/4-20 X 1.75 HHCS		
34	86232780	279001	-	CHAIN MASTERLINK 12.7MM		

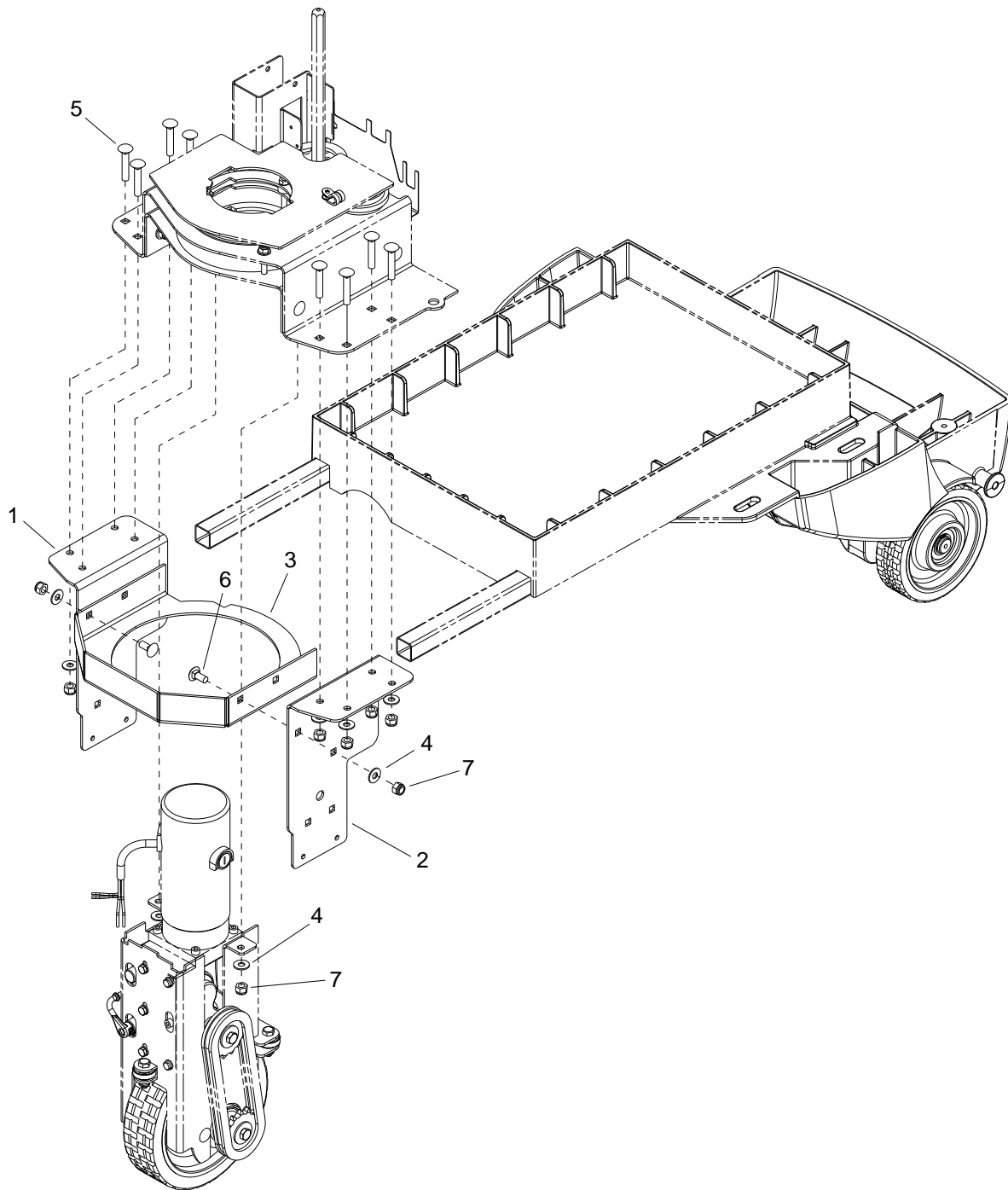

REF	PART NO.	PRV NO.	QTY	DESCRIPTION	SERIAL NO. FROM	NOTES
1	86326080	-	1	BRACKET, LINKAGE MOUNT, RIGHT		
2	86319730	-	1	BRACKET, LINKAGE MOUNT, LEFT		
3	86331630	-	1	BRACKET, ROLLER GUIDE		
4	86010670	87029	12	WASHER, 5/16 X 3/4 SS		
5	86276690	70715	8	SCR, 5/16-18 X 1.75 CARR SS		
6	86276070	70593	2	SCR, 5/16-18 X 3/4 CARRIAGE SS		
7	86270830	57023	12	NUT, 5/16-18 HEX NYLOCK SS		

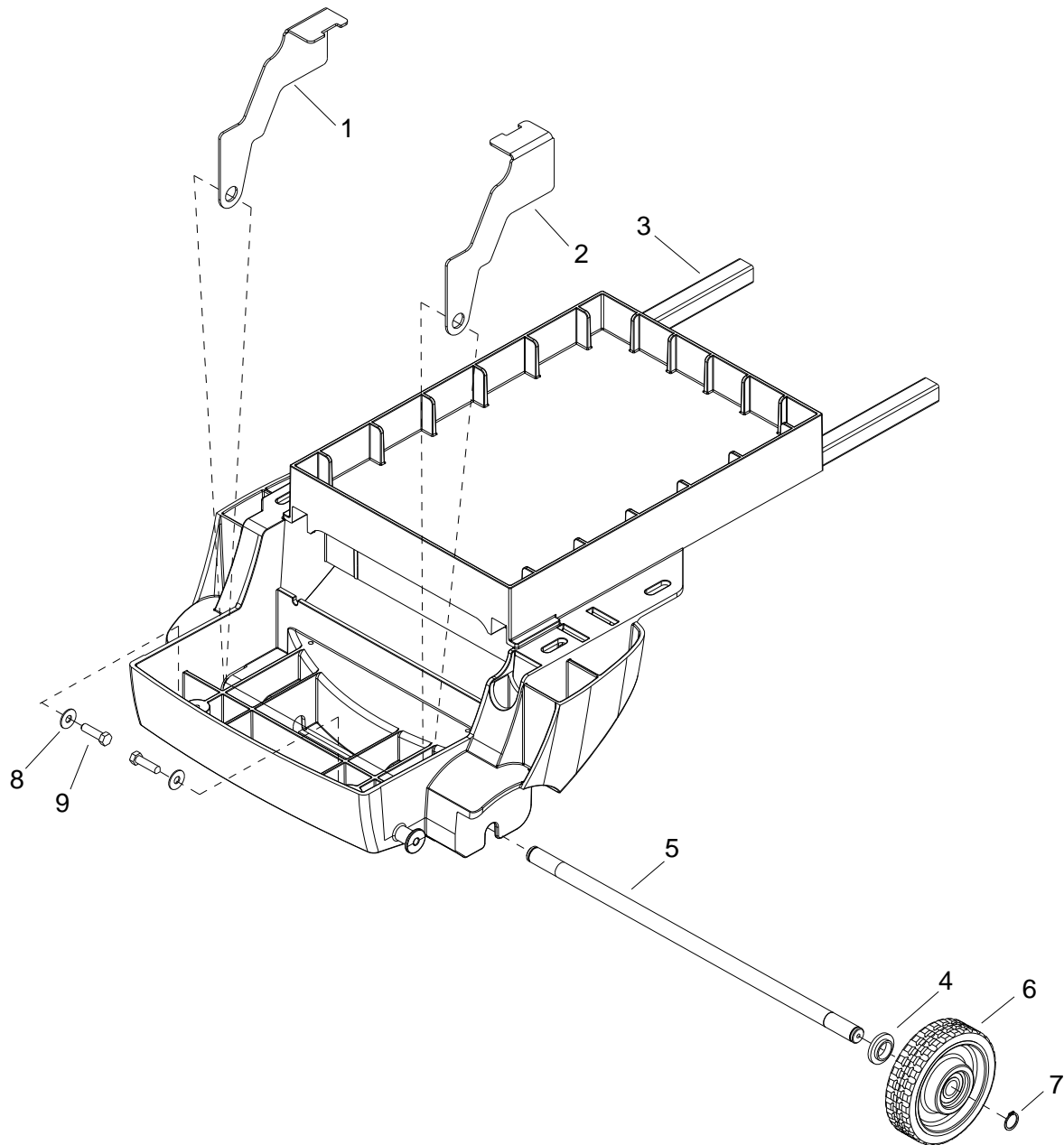

REF	PART NO.	PRV NO.	QTY	DESCRIPTION	SERIALNO. FROM	NOTES
1	86326260	-	1	BRACKET, FRAME LEFT		
2	86326250	-	1	BRACKET, FRAME RIGHT		
3	86340610	-	1	ASM FRAME, CS20		INCLUDES ITEM 8 & 9
4	86326220	-	2	SPACER, FLG .887ID X 1.055D X .345LG		
5	86318030	-	1	AXLE, 20MM X 562 MM		
6	86318020	-	2	WHEEL, PU 150MM X 40MM		
7	86223470	67449	2	RING, 20MM EXTERNAL SNAP		
8	86279510	87171	2	WASHER 3/8 FLAT		
9	86340950	-	2	SCR, 3/8 X 1.5, LAG, PLTD		

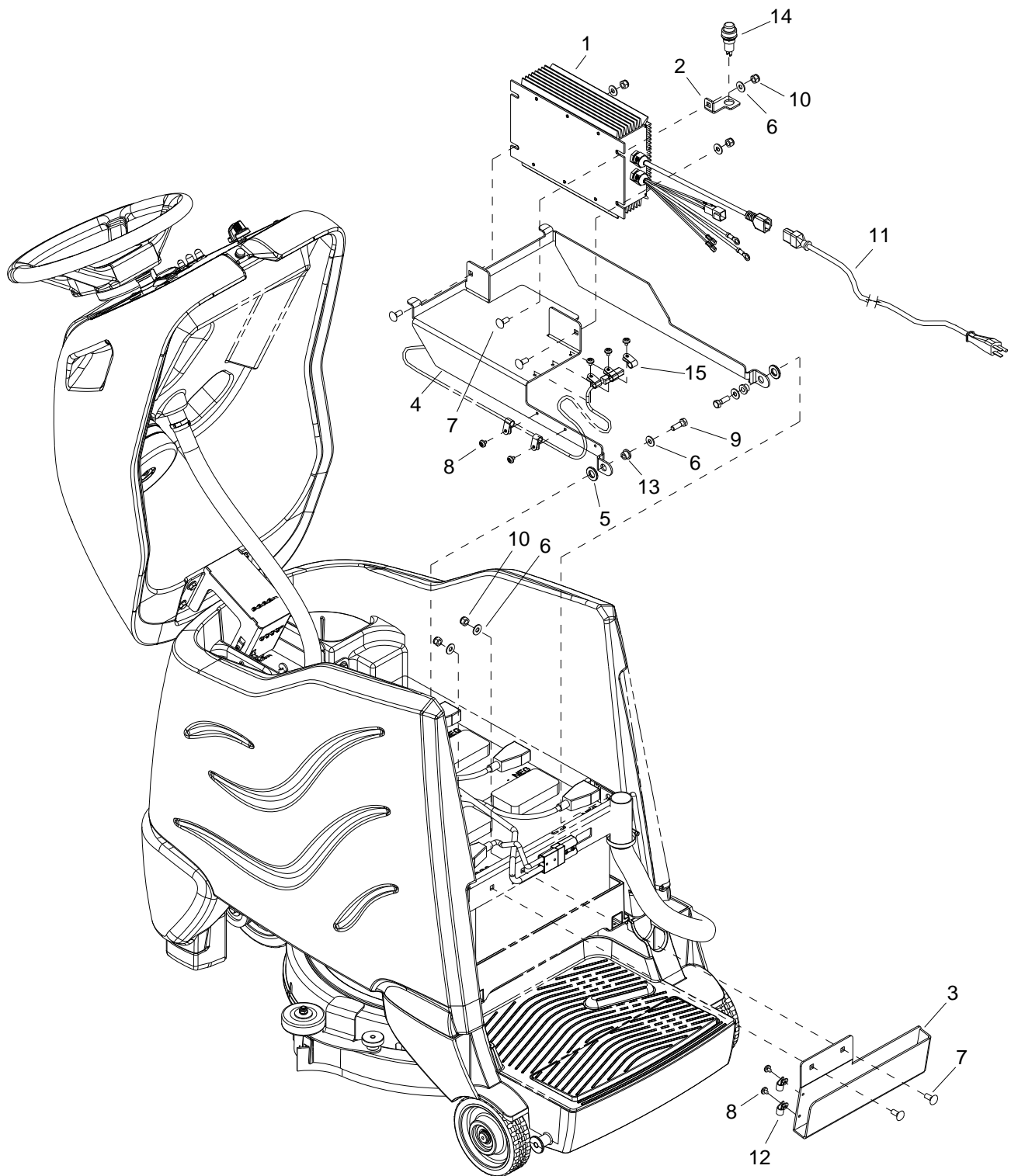

REF	PART NO.	PRV NO.	QTY	DESCRIPTION	SERIAL NO. FROM	NOTES
1	98408740	-	1	KIT, CHARGER, SPE 36V 15A		
2	86332690	-	1	BRKT, CHARGER METER		
3	86332370	-	1	BRACKET, CORD WRAP		
4	86327690	-	1	BRACKET, CHARGER		
5	86259400	87205	2	WASHER, THRUST .51 ID X 1 ODBRO		
6	86010670	87029	7	WASHER, 5/16 X 3/4 SS		
7	86276070	70593	5	SCR, 5/16-18 X 3/4 CARRIAGE SS		
8	86006770	70323	7	SCR, 10-32 X 1/4 PHTR PLTD		
9	86006750	70302	2	SCR, 5/16-18 X 1.00 HHCS GR5		
10	86270830	57023	5	NUT, 5/16-18 HEX NYLOCK SS		
11	86234390	23725	1	CORD ASM, 16/3 SJTWX2M IEC		
12	86198450	20005	2	CLAMP, 5/16 DIA NYLON		
13	86228990	09153	2	BEARING FLG .314IDX.5002OD		
14	86333070	-	1	METER, SPE BATTERY CHARGE		
15	86198470	20015	5	CLAMP, 9/16 DIA NYLON		

On Board Battery Charger-CSXC20

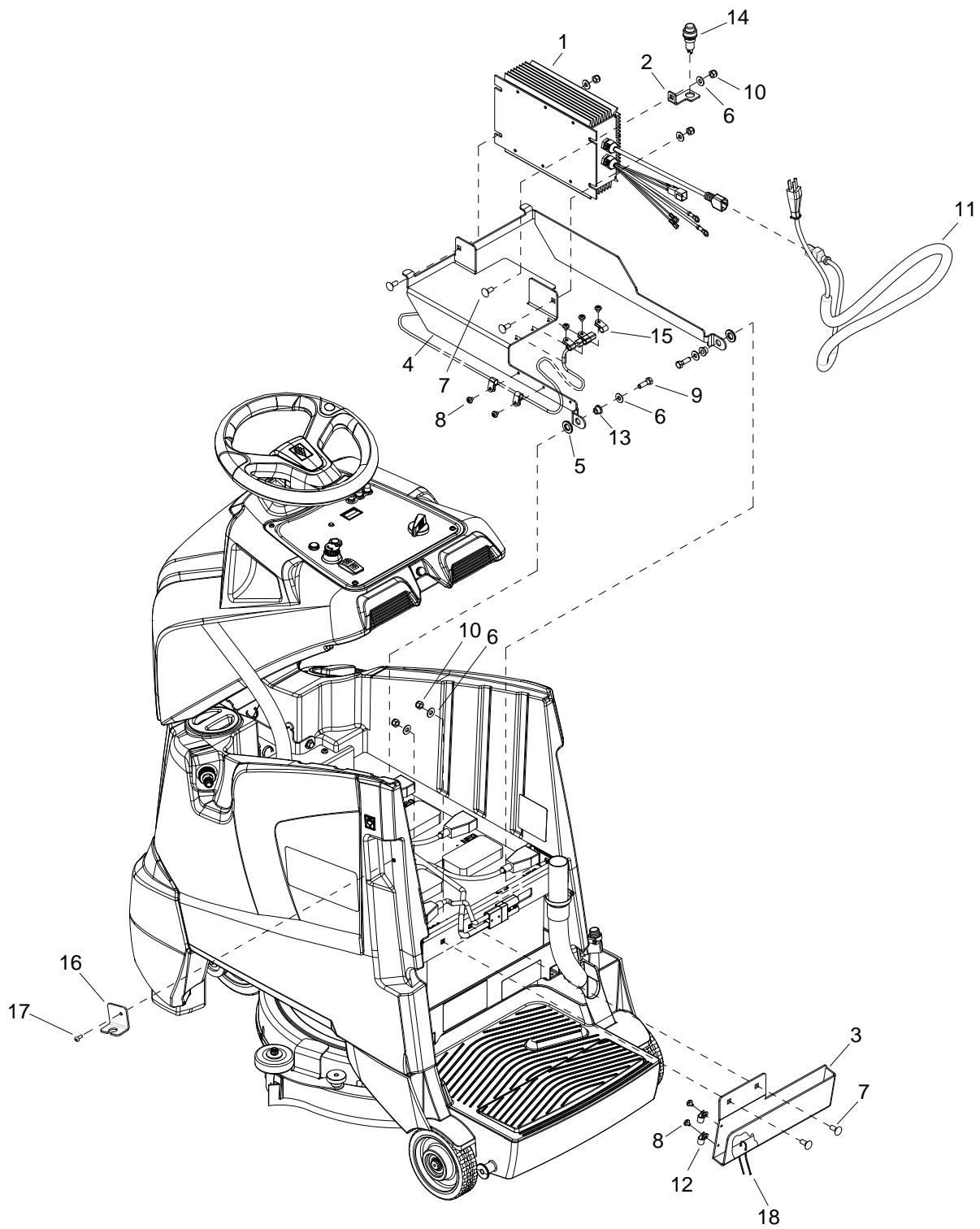

REF	PART NO.	PRV NO.	QTY	DESCRIPTION	SERIAL NO. FROM	NOTES
1	98408740	-	1	KIT, CHARGER, SPE 36V 15A		
2	86332690	-	1	BRKT, CHARGER METER		
3	86348390	-	1	BRACKET, CORD STORAGE DELUXE		
4	86327690	-	1	BRACKET, CHARGER		
5	86259400	87205	2	WASHER, THRUST .51 ID X 1 ODBRO		
6	86010670	87029	7	WASHER, 5/16 X 3/4 SS		
7	86276070	70593	5	SCR, 5/16-18 X 3/4 CARRIAGE SS		
8	86006770	70323	7	SCR, 10-32 X 1/4 PHTR PLTD		
9	86006750	70302	2	SCR, 5/16-18 X 1.00 HHCS GR5		
10	86270830	57023	5	NUT, 5/16-18 HEX NYLOCK SS		
11	86345510	-	1	CORD, ONBOARD CHARGER, 16/3C SJTO		
12	86198450	20005	2	CLAMP, 5/16 DIA NYLON		
13	86228990	09153	2	BEARING FLG .314IDX.5002OD		
14	86333070	-	1	METER, SPE BATTERY CHARGE		
15	86198470	20015	5	CLAMP, 9/16 DIA NYLON		
16	86333940	-	-	BRACKET, CHARGER CORD		
17	86006590	70088	1	SCREW 10-32 X 1/2 PPHMS SS NP		
18	86264940	27051	1	CABLE TIE, 11.38" UL/CSA		

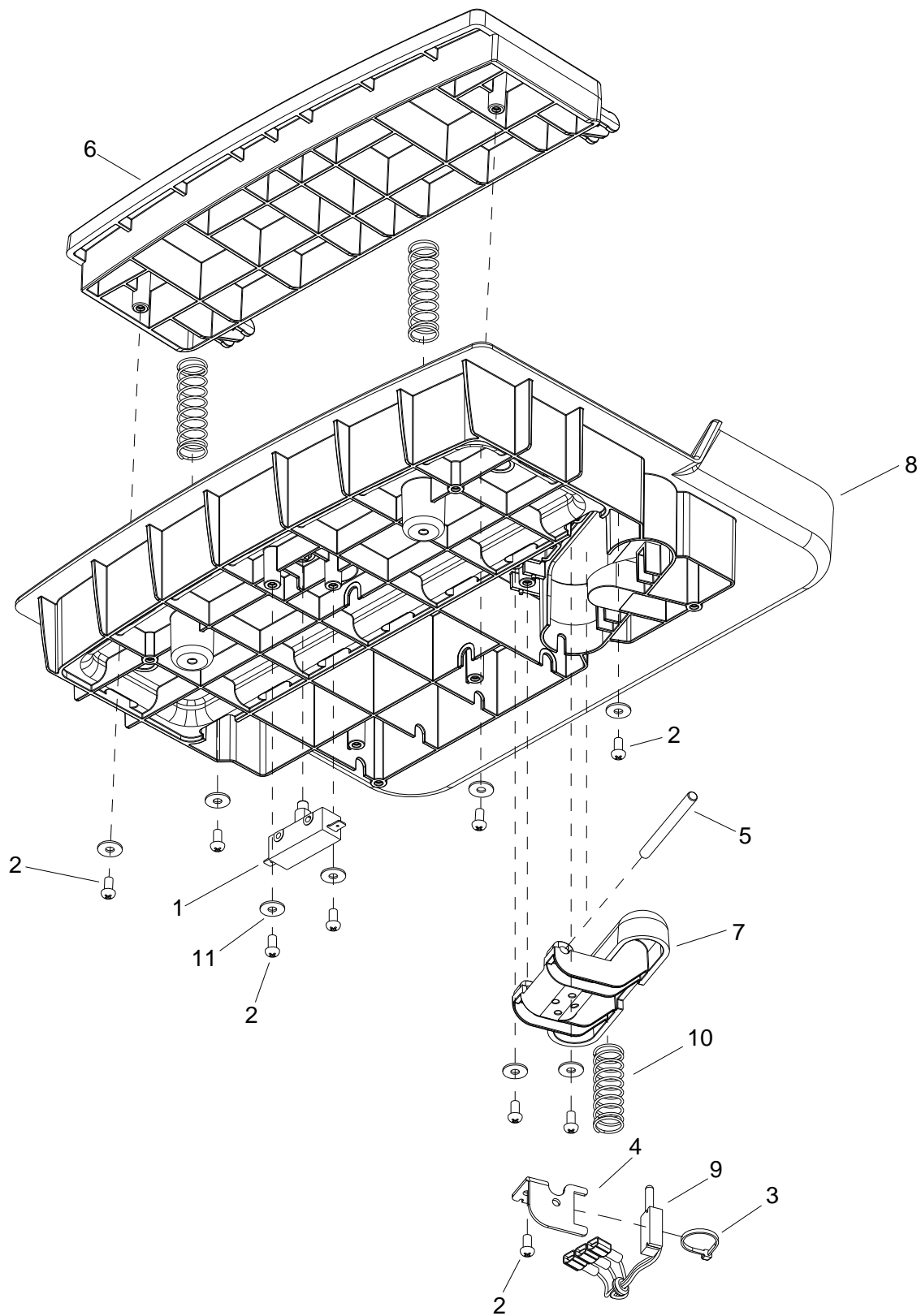

REF	PART NO.	PRV NO	QTY	DESCRIPTION	SERIAL NO. FROM	NOTES
1	86007110	72123	1	SWITCH, 25A SPST 125-250V SNAP		
2	86172980	70912	9	SCR, KA50X10, PT OHS, WN1412, PLTD		
3	86264930	27050	1	CABLE TIE, 3.5" UL/CS		
4	86326150	-	1	BRKT, LINEAR POT		
5	86326140	-	1	PIN, DOWEL .25 X 2.75, STEEL		
6	86318010	-	1	PEDAL, HEEL		
7	86318000	-	1	PEDAL, ACCELERATOR		
8	86317990	-	1	PLATFORM, OPERATOR		
9	86311560	-	1	POTENTIOMETER ASM, LINEAR		
10	86254970	730304	3	SPRING, COMP 18MM OD X 83 X 2		
11	86173330	87513	8	WASHER, M5, FLAT, ISO7093, SS		

Pedal Platform Mounting

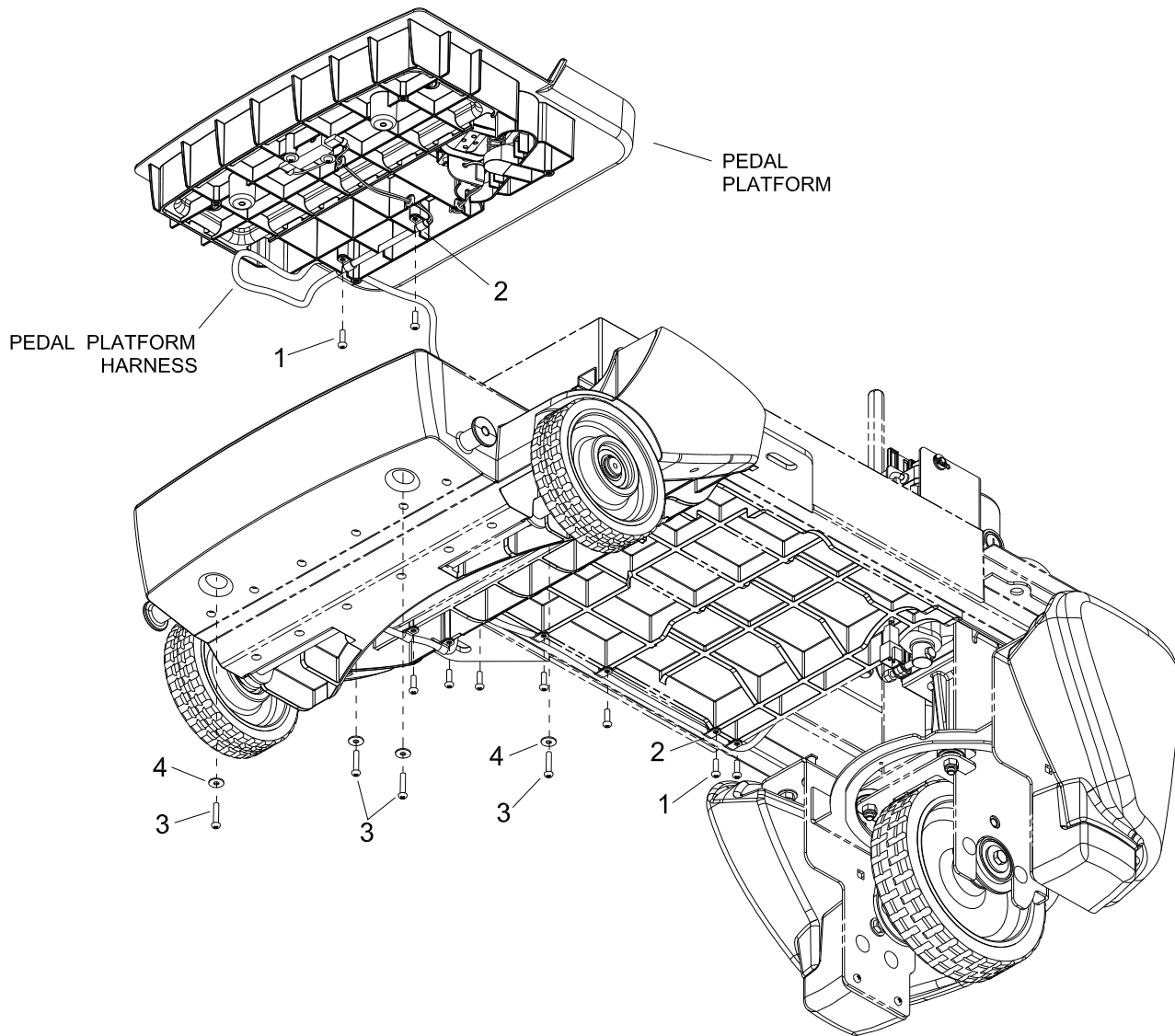

REF	PART NO.	PRV NO	QTY	DESCRIPTION	SERIAL NO. FROM	NOTES
1	86327510	-	9	SCR, KA50 X 16, WN1412 A2 SS		
2	86198440	20004	9	CLAMP, 1/4 PLASTIC CABLE		
3	86327910	-	4	SCR, KA50X25, PT OHS, WN1412, PLTD		
4	86173330	87513	4	WASHER, M5, FLAT, ISO7093, SS		

Recovery Tank

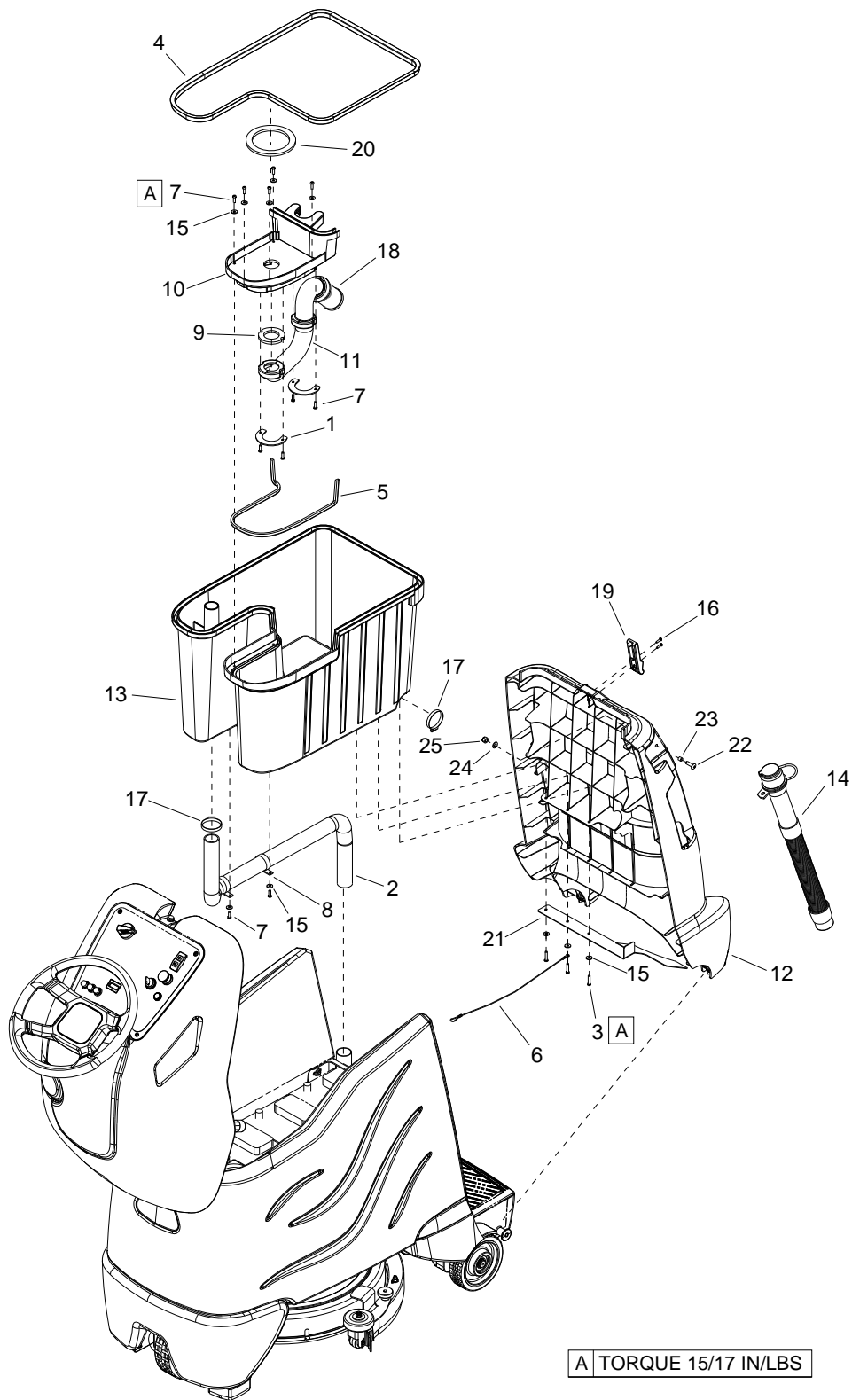

REF	PART NO.	PRV NO.	QTY	DESCRIPTION	SERIAL NO. FROM	NOTES
1	86329510	-	2	PLATE, INTAKE RETAINER		
2	86328020	-	1	HOSE ASM, 1.25 ID X 18.0, 4:1		
3	86327910	-	3	SCR, KA50X25, PT OHS, WN1412, PLTD		
4	86327850	-	1	GASKET, REC TANK 68"		
5	86327840	-	1	GASKET, VAC MOUNT 27"		
6	86327590	-	1	LANYARD, 15.0 W/LOOP & EYE		
7	86327510	-	11	SCR, KA50X16, PT OHS, WN1412, A2 SS		
8	86326270	-	2	CLAMP, 1.5 DIA		
9	86326200	-	1	GASKET, VACUUM INTAKE		
10	86318220	-	1	FRAME, VACUUM MOTOR		
11	86318210	-	1	INTAKE, VACUUM		
12	86344710	-	1	PANEL, BACK		
13	86317920	-	1	TANK, RECOVERY		
14	86302360	-	1	DRAIN HOSE, CMPS		
15	86173330	87513	10	WASHER, M5, FLAT, ISO7093, SS		
16	86173140	70945	2	SCR,KA40X16,PT OVAL,WN1412,PL		
17	86002400	20064	2	CLAMP, 2.00 WORM GEAR X .312		
18	86199840	090-12A	1	FLOAT SCREEN CAGE ASSY (SLIP)		
19	86161800	46-802531	1	LATCH, CONCEALED KEEPER		
20	86312920	-	1	GASKET, VAC MOTOR		
21	86335700	-	1	BRACKET, DRAIN HOSE	*(3)	
22	86007070	70849	1	SCREW 5/16-18 X 1.00 PTHMS SS	*(6)	
23	86007650	730329	1	SPACER, .438D X .317ID X .25L	*(6)	
24	86010670	87029	1	WASHER 5/16 FLAT SS	*(6)	
25	86270830	57023	1	NUT 5/16-18 HEX NYLOCK SS	*(6)	

* SEE SERIAL NUMBER PAGE.

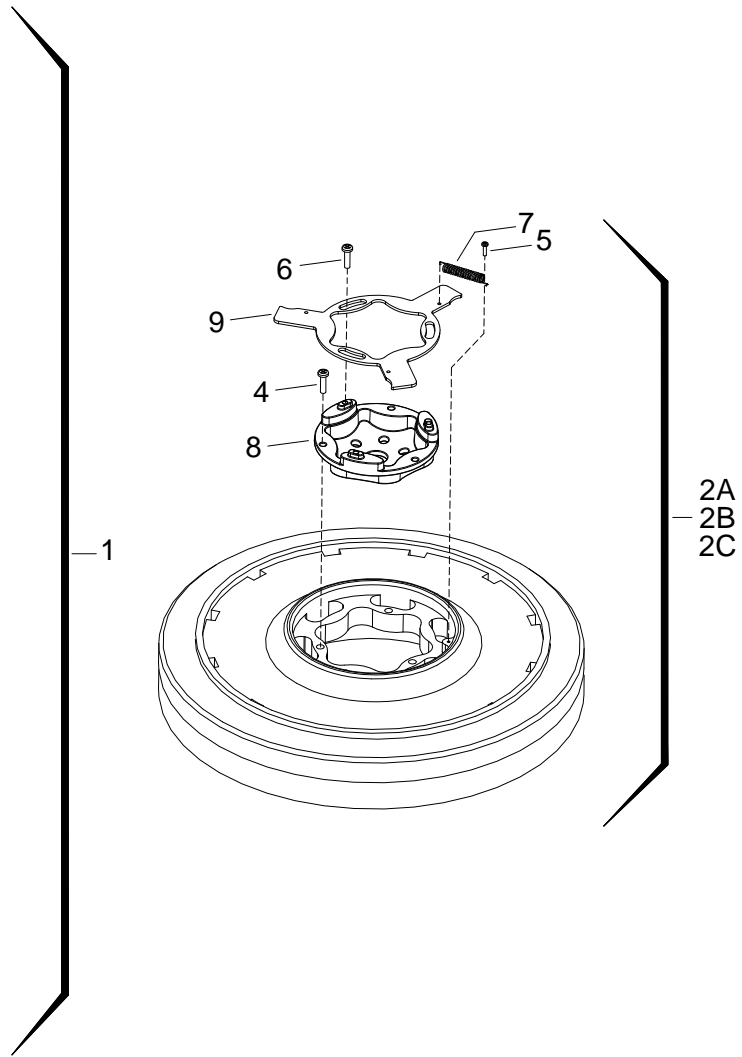
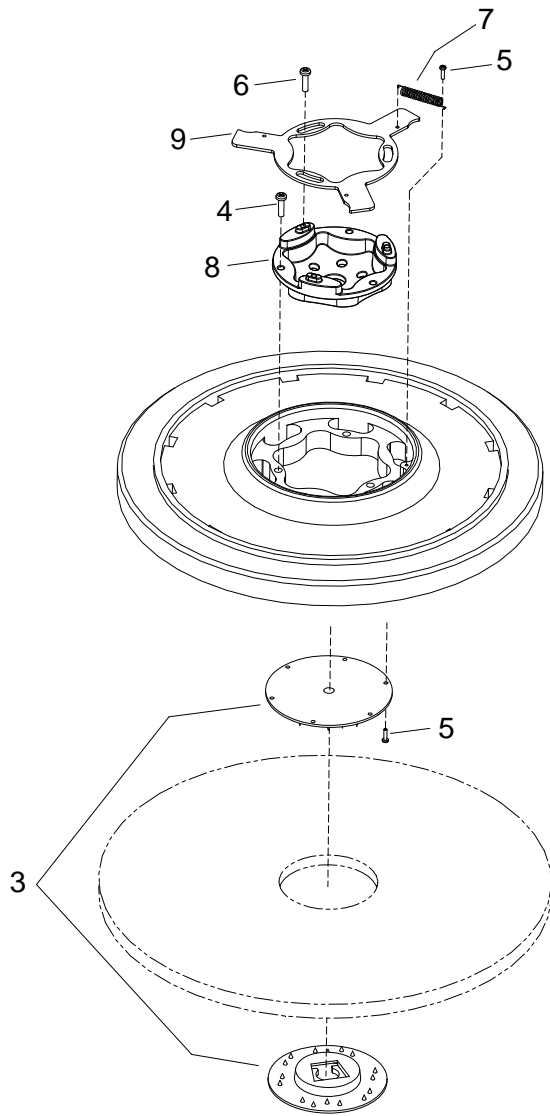

REF	PART NO.	PRV NO.	QTY	DESCRIPTION	SERIAL NO. FROM	NOTES:
1	86000410	02436	1	PAD DRIVER, 20" SD		
2A	86000420	02437	1	BRUSH, 20" POLYPROPYLENE SD		
2B	86000430	02438	1	BRUSH, 20" NYLON SD		
2C	86283870	02439	1	BRUSH, 20" NYLON POLISH SD		
3	86005070	51284	1	LOCK, PAD CENTER SNAP, TWO STEP		
4	86276590	70695	3	SCR, #12 X 1 PPHSMS SS		
5	86276580	70694	1	SCR, 8-32 X 3/4 PTHMS		
6	86276600	70696	3	SCR, #10 X 3/4 PTHSMS SS		
7	86007910	73817	1	SPRING, EXT .31 D X 2.0 L X .03 W SS		
8	86007280	730011	1	SOCKET, DRIVE BRUSH		
9	86005940	62852	1	PLATE, BRUSH RELEASE		

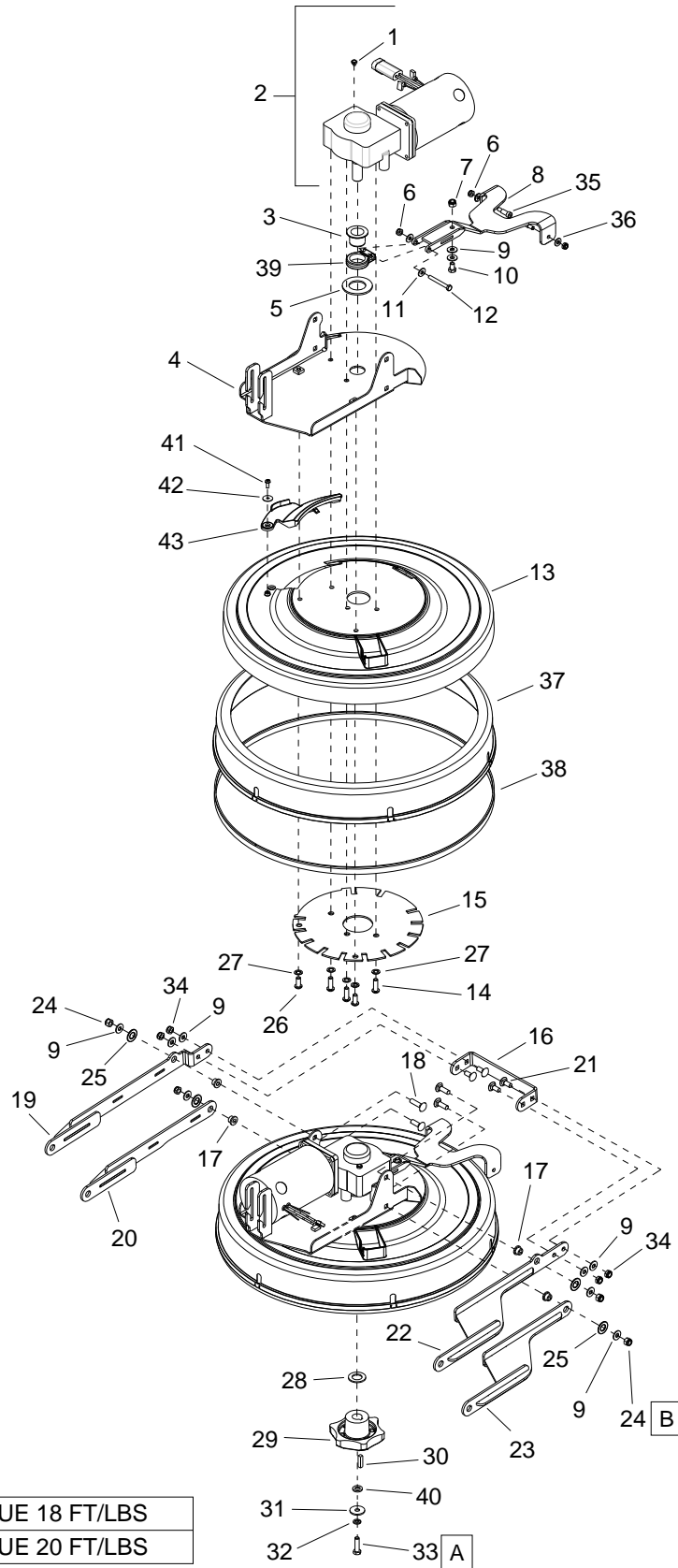

REF	PART NO.	PRV NO.	QTY	DESCRIPTION	SERIAL NO. FROM	NOTES
1	86331340	-	1	BREATHER VENT, 10-32 THREAD		
2	86331970	-	1	MOTOR, 36VDC 180RPM RT-ANG		INCLUDES 86331340
-	86331980	-	-	BRUSH SET, 8.633-197.0 SCRUB MTR		
3	86325200	-	1	BUSHNG, 30MM, BRNZ		
4	86326430	-	1	SUPPORT ASSY, MOTOR, BRUSH DECK		
5	86326560	-	1	WASHER, NYLON, 2.28ODX1.28IDX.12 THK		
6	86271870	57290	3	NUT, 1/4-20 HEX NYLCK THIN SS		
7	86222300	57309	1	NUT, 5/16-18 JAM SS C		
8	86320370	-	1	LINKAGE ARM ASSY, PIVOT SQUG		
9	86010670	87029	10	WASHER 5/16 FLAT SS		
10	86328620	-	1	SCR, 5/16-18 X 1/2 LG, HHCS, BLK NYLON		
11	86279070	87056	2	WASHER, M6 FLAT		
12	86273850	70022	1	SCR, 1/4-20 X 2 HHCS SS		
13	86319800	-	1	SHROUD, 20" SCRUB DECK		
14	86329560	-	3	SCR, M8X1.25X25MM LG, BSHCS, SS		
15	86326550	-	1	SUPPORT PLATE, SHROUD		
16	86326540	-	1	BRIDGE BRKT, DECK LIFT		
17	86228990	09153	4	BEARING,FLNGD,.314ID X.502OD		
18	86277130	70795	4	SCREW 5/16-18X1.00 CARRIAGE SS		
19	86326600	-	1	BRKT, DECK LIFT, UPPER RIGHT		
20	86326610	-	1	BRKT, DECK LIFT, LOWER RIGHT		
21	86276070	70593	4	SCR, 5/16-18 X 3/4 CARRIAGE SS		
22	86326580	-	1	BRKT, DECK LIFT, UPPER LEFT		
23	86326590	-	1	BRKT, DECK LIFT, LOWER LEFT		
24	86270830	57023	4	NUT 5/16-18 HEX NYLOCK SS		
25	86259410	87206	4	WASHER THRUST.51 ID X1ODX.063		
26	86290040	-	2	SCR, 5/16-18 X 3/4 BSHCS SS		
27	86330990	-	5	WASHER, 5/16 INT STAR, SS		
28	86337200	-	1	WASHER, 19MM X 34MM X 3MM FLAT SS	*(1)	
29	86003420	29220	1	DRIVER, BRUSH SD		
30	86004810	48040	1	KEY, 1/4 SQ X 1.00		
31	86279630	87212	1	WASHER, .344IDX1.13ODX.09T PLT		
32	86279130	87083	1	WASHER 5/16 SPLIT LOCK PLTD		
33	86330970	-	1	SCR, M8X1.25X25MM LG, HHCS, SS		
34	86271840	57285	4	NUT 5/16-18 HEX NYLOCK THIN SS		
35	86327700	-	2	SHOULDER BOLT, 5/16 X 5/8 LG SS		
36	86010630	87013	2	WASHER 1/4 ID X 5/8 OD SS		
37	86320430	-	1	20" BRUSH SKIRT		
38	86328220	-	1	FLEXIBLE STRIP BRUSH, 20" SKIRT		
39	86319820	-	1	PIVOT, SQUEEGEE LINKAGE		
40	86338440	-	1	SPACER, .41 ID X .73 OD X .105T	*(1)	
41	86006870	70406	1	SCREW #10B X 1/2 PHMS BLK		
42	86335450	-	1	WASHER, #10 X .75 ODX.040. NYL, BLK		
43	86324480	-	1	ACCESS COVER, BRUSH RELEASE		

* SEE SERIAL NUMBER PAGE

** CALL MANUFACTURER FOR SERIAL NUMBER

Scrub Brush Deck Mounting

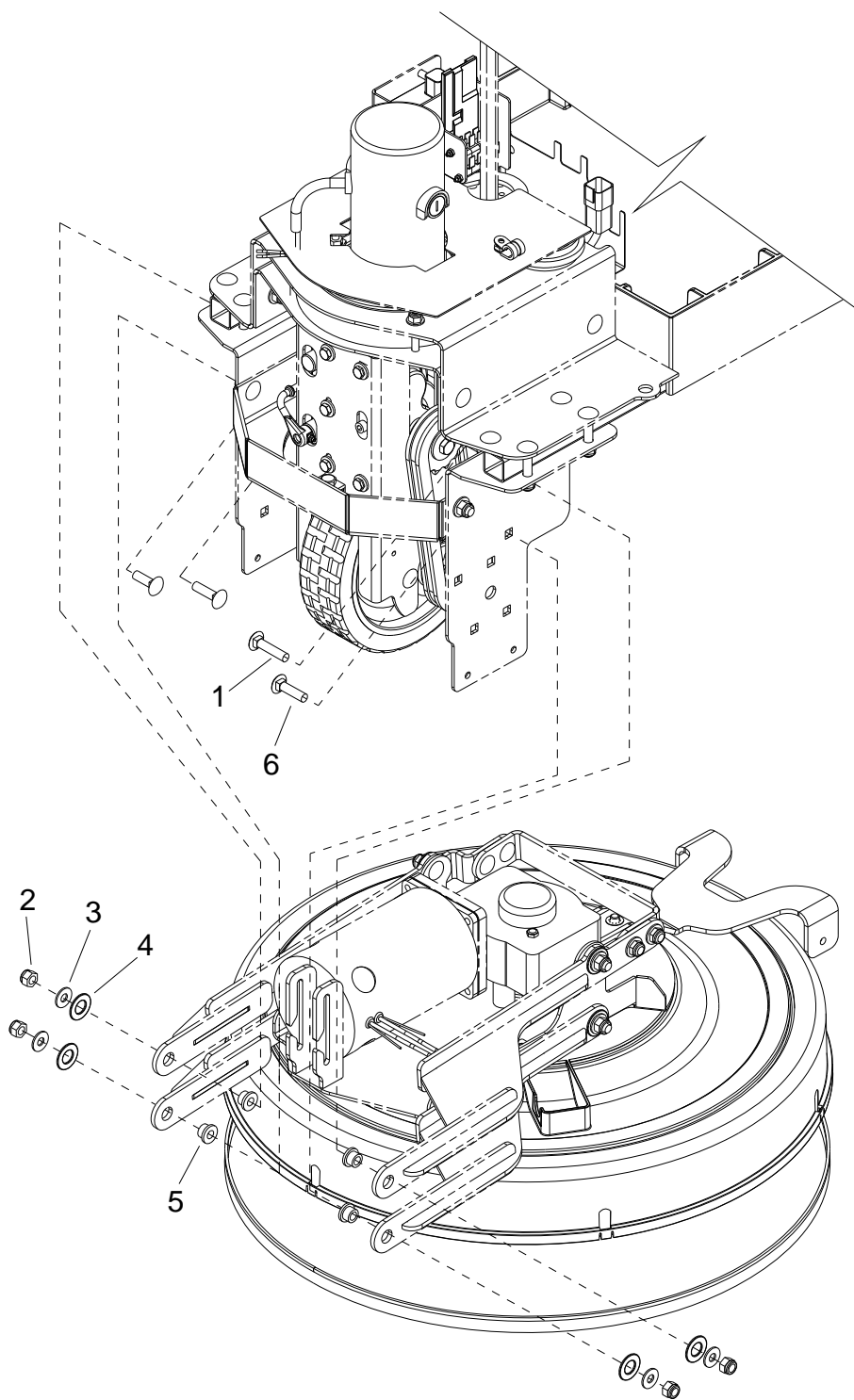

REF	PART NO.	PRV NO.	QTY	DESCRIPTION	SERIAL NO. FROM	NOTES
1	86277030	70780	4	SCR, 5/16-18X1.25 CARRIAGE S		
2	86270830	57023	4	NUT 5/16-18 HEX NYLOCK SS		
3	86010670	87029	4	WASHER 5/16 FLAT SS		
4	86259410	87206	4	WASHER THRUST.51 ID X1ODX.063		
5	86228990	09153	4	BEARING,FLNGD,.314ID X.502OD		
6	86277130	70795	2	SCR, 5/16-18 X 1.00 CARRIAGE SS		

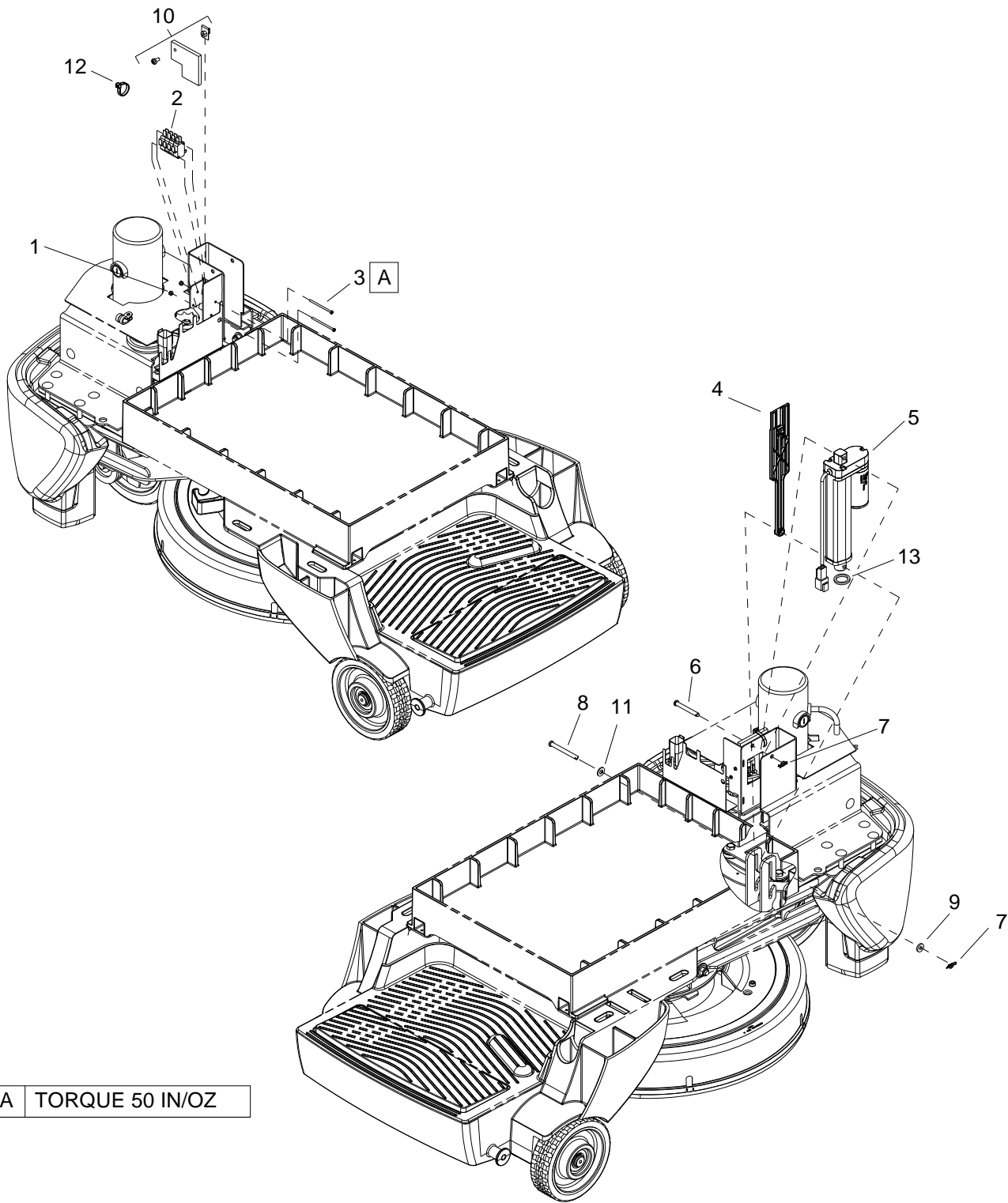

REF	PART NO.	PRV NO.	QTY	DESCRIPTION	SERIAL NO. FROM	NOTES
1	86271660	57233	2	NUT 4-40 HEX NYLOCK		
2	86007160	72157	4	SWITCH 10A ROLLER MINI		
3	86327390	-	2	SCR, 4-40 X 2 PPHMS		
4	86323850	-	1	PLATE, SWITCH ACTUATOR		
5	86320880	-	1	ACT, 36VDC, 3.0" STK, 8.74 LNG		
6	86328040	-	1	PIN, CLEVIS, 1/4 X 2.0 L		
7	86008650	80604	2	COTTER 1/4" RING		
8	86336790	-	1	PIN, CLEVIS, 1/4 X 2.50. PLTD	*(2)	
9	86279610	-	1	WASHER, SEAL 1/4X5/8OD SS		
10	86338480	-	1	GUIDE PLATE ASM	*(2)	
11	86010630	87013	1	WASHER 1/4 ID X 5/8 OD SS		
12	86264940	-	1	CABLE TIE, 11.38" UL/CSA	*(2)	
13	86342240	-	1	SPACER, .81 X 1.06 X .125	*(4)	

*SEE SERIAL NUMBER PAGE

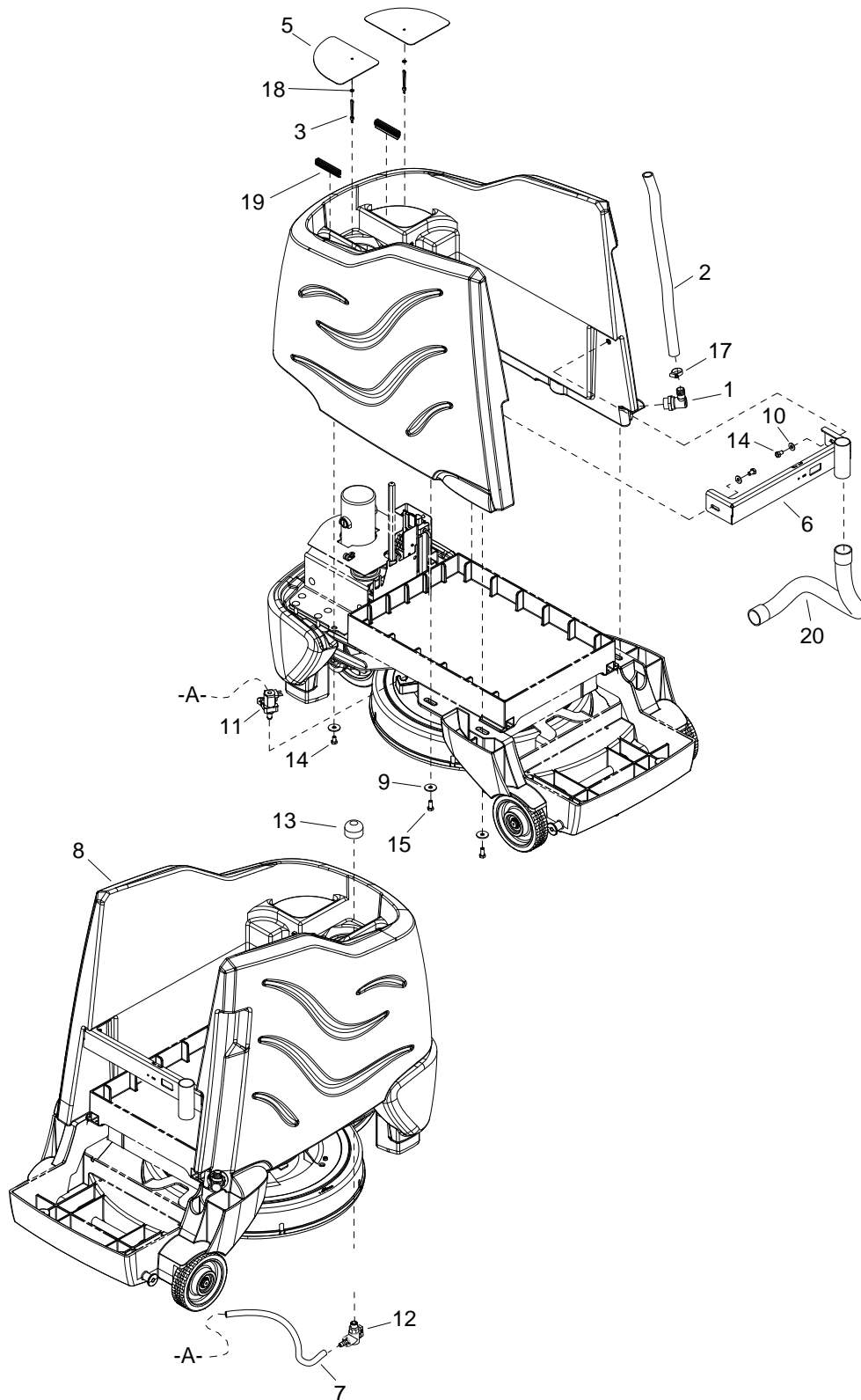

REF	PART NO.	PRV NO	QTY	DESCRIPTION	SERIAL NO. FROM	NOTES
1	86326310	-	1	FITTING, ELBOW 3/4 BSP, O-RING		
2	86326620	-	1	HOSE, 3/4ID X .12W X 20"LG, CLR		
3	86330960	-	2	LANYARD, ELASTIC, .125 X 4.0		
4	OPEN	-	-	-		
5	86329670	-	2	COVER, FILL PORT		
6	86326280	-	1	BRACKET, TANK BRACE		
7	86321270	-	1	HOSE, 3/8ID WIREBOUND X 18"		
8	86317940	-	1	TANK, SOLUTION, CS20		
9	86279630	87212	5	WASHER, .344IDX1.130ODX.09T PLT		
10	86010670	87029	2	WASHER, 5/16 X 3/4 SS		
11	86010610	84203	1	VALVE, 24VDC SOL 3/8 HOSE CIM		
12	86346040	-	1	VALVE, BALL 3/8MPT X 3/8BARB, 90DEG		
13	86007970	73864	1	STRAINER, 3/8 IN. NPT 60 MESH		
14	86275180	70375	4	SCR, 5/16-18 X 1/2 HHCS GR5		
15	86006760	70305	3	SCR, 5/16-18 X 3/4 HHCS GR5		
16	OPEN	-	-	-		
17	86233110	20018	1	CLAMP, 1.00 WORM GEAR		
18	86279600	87187	2	WASHER, #6 FLAT BRASS		
19	86333260	-	2	GASKET, 3.0", FILL PORT		
20	86328020	-	1	HOSE ASM, 1.25 ID X 14.0, 4:1		

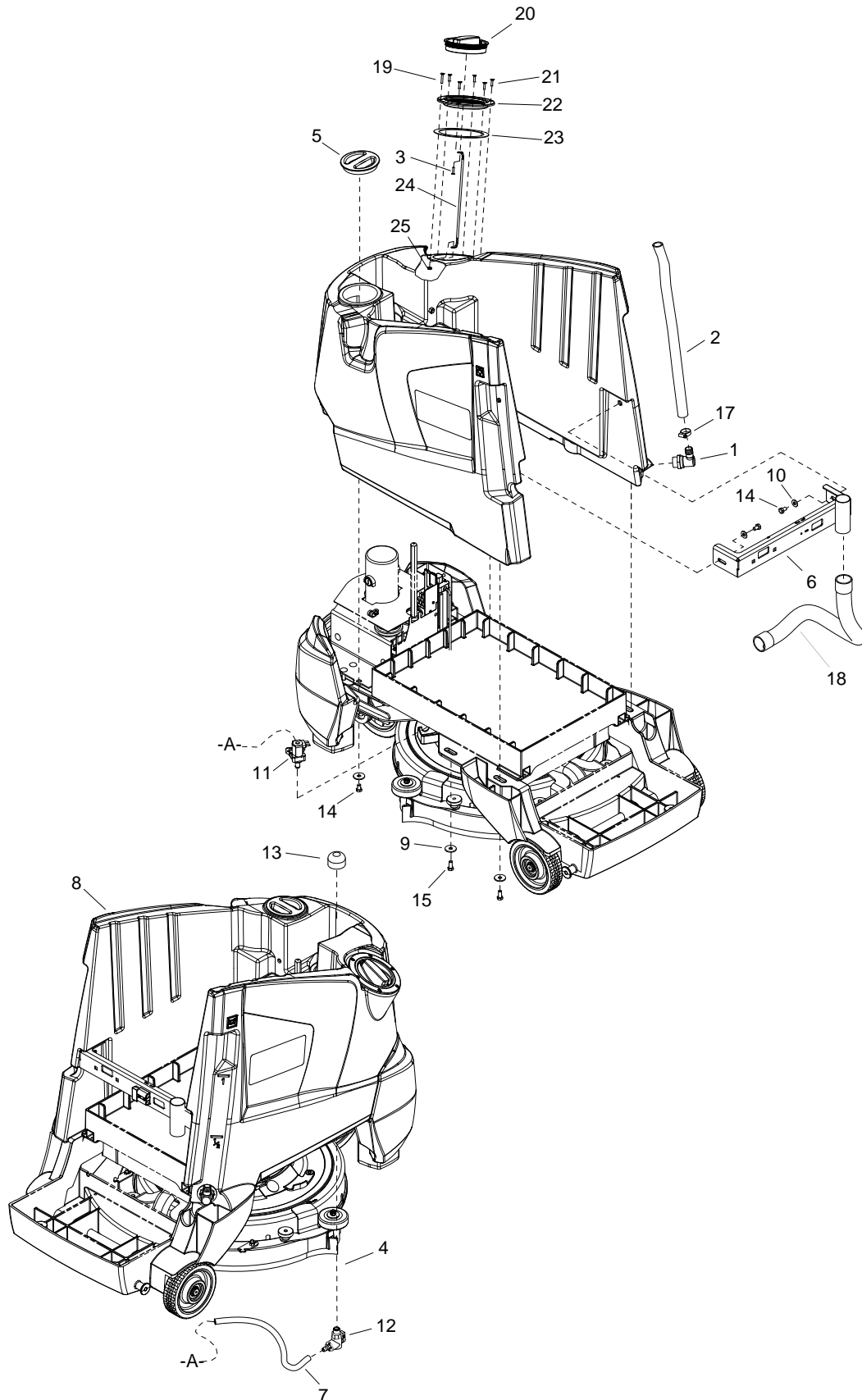

REF	PART NO.	PRV NO	QTY	DESCRIPTION	SERIAL NO. FROM	NOTES
1	86326310	-	1	FITTING, ELBOW 3/4 BSP, O-RING		
2	86326620	-	1	HOSE, 3/4ID X .12W X 20"LG, CLR		
3	86327510	-	1	SCR, KA50 X 16, WN1412 A2 SS		
4	OPEN	-	-	-		
5	50643110	-	1	COVER		
6	86326280	-	1	BRACKET, TANK BRACE		
7	86321270	-	1	HOSE, 3/8ID WIREBOUND X 18"		
8	86342820	-	1	TANK, SOLUTION CSX20		
9	86279630	87212	5	WASHER, .344IDX1.130ODX.09T PLT		
10	86010670	87029	2	WASHER, 5/16 X 3/4 SS		
11	86010610	84203	1	VALVE, 24VDC SOL 3/8 HOSE CIM		
12	86346040	-	1	VALVE, BALL 3/8MPT X 3/8BARB, 90DEG		
13	86007970	73864	1	STRAINER, 3/8 IN. NPT 60 MESH		
14	86275180	70375	4	SCR, 5/16-18 X 1/2 HHCS GR5		
15	86006760	70305	3	SCR, 5/16-18 X 3/4 HHCS GR5		
16	OPEN	-	-	-		
17	86233110	20018	1	CLAMP, 1.00 WORM GEAR		
18	86308020	-	1	HOSE ASM, 1.25 ID X 14.0, 4:1		
19	86339990	-	1	SCR, 8-32 X 1.0, FHMS, PHLPS, SS, BLK		
20	86314160	-	1	COVER, FILLPORT 4"		
21	86275800	70546	5	SCREW 8 X 3/4 PFHT/S BLK ZINC		
22	86317620	-	1	FLANGE, WITH O-RING		
23	86317610	-	1	GASKET, 5.5 ODX4.5 IDX.06W/PSA		
24	86232790	-	1	CHAIN,ASM, #10SS BD X 10"		
25	86272020	-	1	NUT, 8-32 HEX THIN NYLOCK SS		

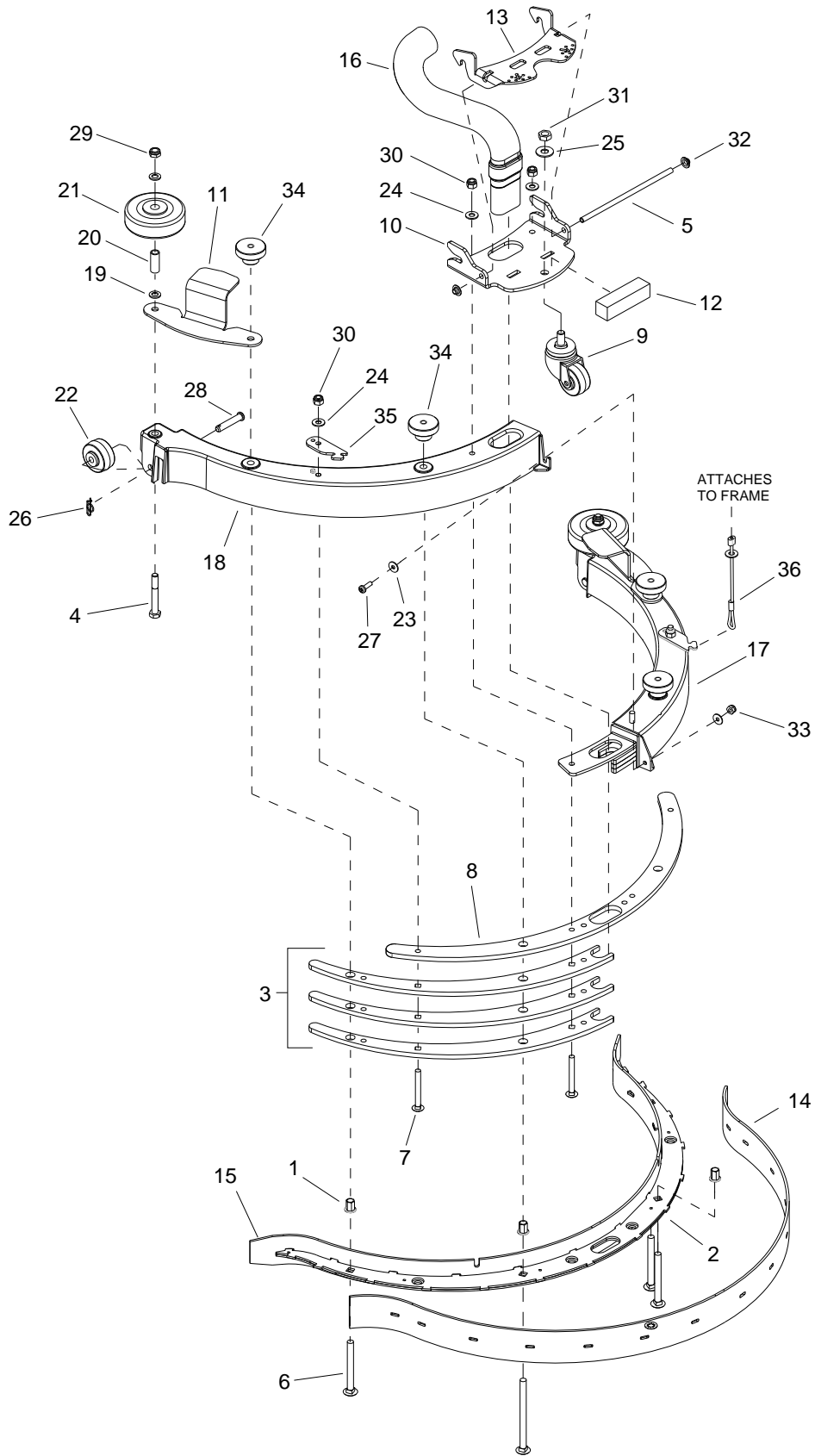

REF	PART NO.	PRV NO.	QTY	DESCRIPTION	SERIAL NO. FROM	NOTES
1	86332060	-	4	RIV-NUT, HEX, 5/16-18X.562, CLEAR CAD		
2	86327860	-	1	SQUEEGEE BLADE RETAINER ASSY		
3	86327790	-	6	PLATE, WEIGHT, SQUEEGEE		
4	86326520	-	2	SCR, 5/16-18 X 2.25 HHCS SS		
5	86326510	-	1	PIVOT SHAFT, LATCH		
6	86326490	-	4	SCR, 5/16-18 X 3.0 CARRIAGE SS		
7	86326480	-	4	SCR, 1/4-20 X 2.25 CARRIAGE SS		
8	86326470	-	1	BRACE, SQUEEGEE COVER		
9	86326460	-	1	CASTER, 1-5/8, 3/8-24 SHT STUD		
10	86326450	-	1	RECEIVER, LATCH PLATE, SQUEEGEE		
11	86326440	-	2	LIFT BRKT, BUMPER, SQUEEGEE		
12	86326420	-	1	SPRING, RUBBER		
13	86326400	-	1	RECEIVER, LATCH, SQUEEGEE		
14	86326070	-	1	BLADE, SQUEEGEE, REAR, DURO 40		
15	86326060	-	1	BLADE, SQUEEGEE, FRONT, DURO 40		
16	86323910	-	1	VACUUM TUBE, SQUEEGEE		
17	86320730	-	1	COVER, SQUEEGEE-RH		
18	86320720	-	1	COVER, SQUEEGEE-LH		
19	86292500	-	4	WASHER, .324ID X .567OD X .057, SS		
20	86001350	140390	2	BUSHING, SPANNER .435 X 1.10		
21	86011020	89202	2	WHEEL, 3" DIA. CUSHION RUBBER		
22	86010880	89058	2	WHEEL, 1.5 OD X .31 ID X .75 W GRY		
23	86010650	87018	2	WASHER, #10 X 9/16 FLAT		
24	86010630	87013	4	WASHER, 1/4 X 5/8 FLAT SS		
25	86278910	87003	1	WASHER, 3/8 X 7/8 FLAT SS		
26	86008660	80605	2	COTTER, 5/16 RING		
27	86275470	70484	1	SCR, 10-32 X 5/8 PPHMS SS		
28	86006270	66276	2	PIN, CLEVIS 5/16 X 1.63 PLTD		
29	86271840	57285	2	NUT, 5/16-18 HEX NYLOCK THN SS		
30	86005810	57245	4	NUT, 1/4-20 HEX NYLOCK SS		
31	86005800	57217	1	NUT, 3/8-24 HEX JAM, PLTD		
32	86271240	57154	2	NUT, CAP, PUSH, .25"		
33	86270990	57090	1	NUT, 10-32 HEX NYLOCK SS		
34	86219690	48080	4	KNOB, 1.5 OD X 5/16-18		
35	86332400	-	2	LIFT BRKT, DOUBLE SCRUB		
36	86332460	-	2	LANYARD ASSY, COILED CABLE		
-	86338160	-	-	SQUEEGEE ASM, CS20 KIT		COMPLETE

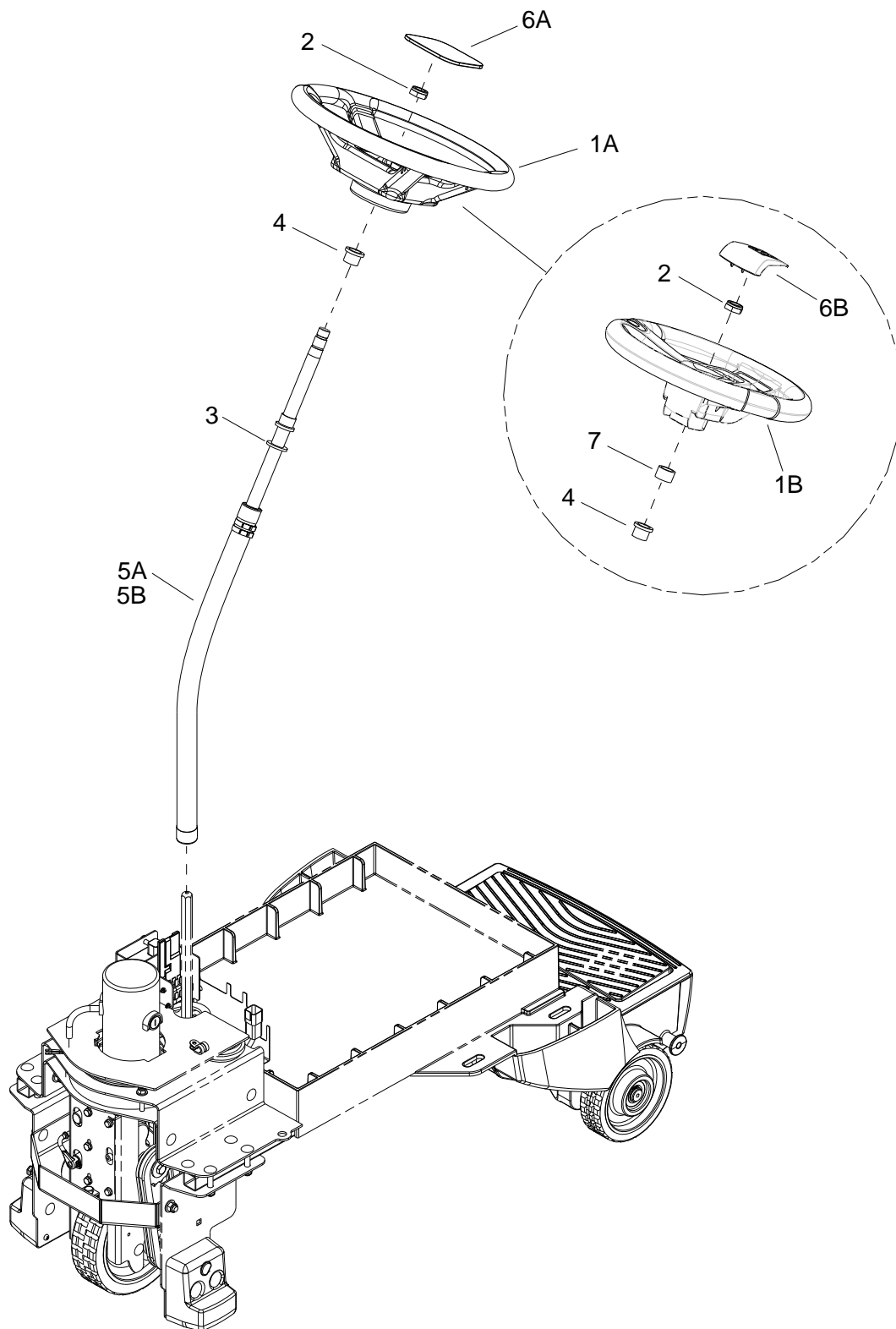

REF	PART NO.	PRV NO.	QTY	DESCRIPTION	SERIAL NO. FROM	NOTES
1A	86259610	730117	1	WHEEL STEERING 40 SPLINE HUB		
1B	64357990	-	1	STEERING WHEEL		DELUXE
2	86271610	57228	1	NUT 5/8-18 HEX NYLOCK THN		
3	86279420	87156	1	WASHER,.75IDX1.25ODX.125THK NY		
4	86228790	09111	2	BEARING FLANGE .88ODX.75IDX.75		
5A	86339320	-	1	SHAFT, STEERING KIT CS20		
5B	86338330	-		SHAFT, STEERING ASM		DELUXE
6A	86234810	27945	1	COVER, STEERING WHEEL		
6B	66403520	-	1	CAP STEERING WHEEL WINDSOR		DELUXE
7	86333950	-	1	BEARING, .75ID X 1.0OD X .63		DELUXE

FOR VACUUM MOTOR REPLACEMENT

MOUNT .80" FROM SEALING SURFACE OF
CONSOLE TO BOTTOM OF WASHER ON
MOUNTING TABS (3).

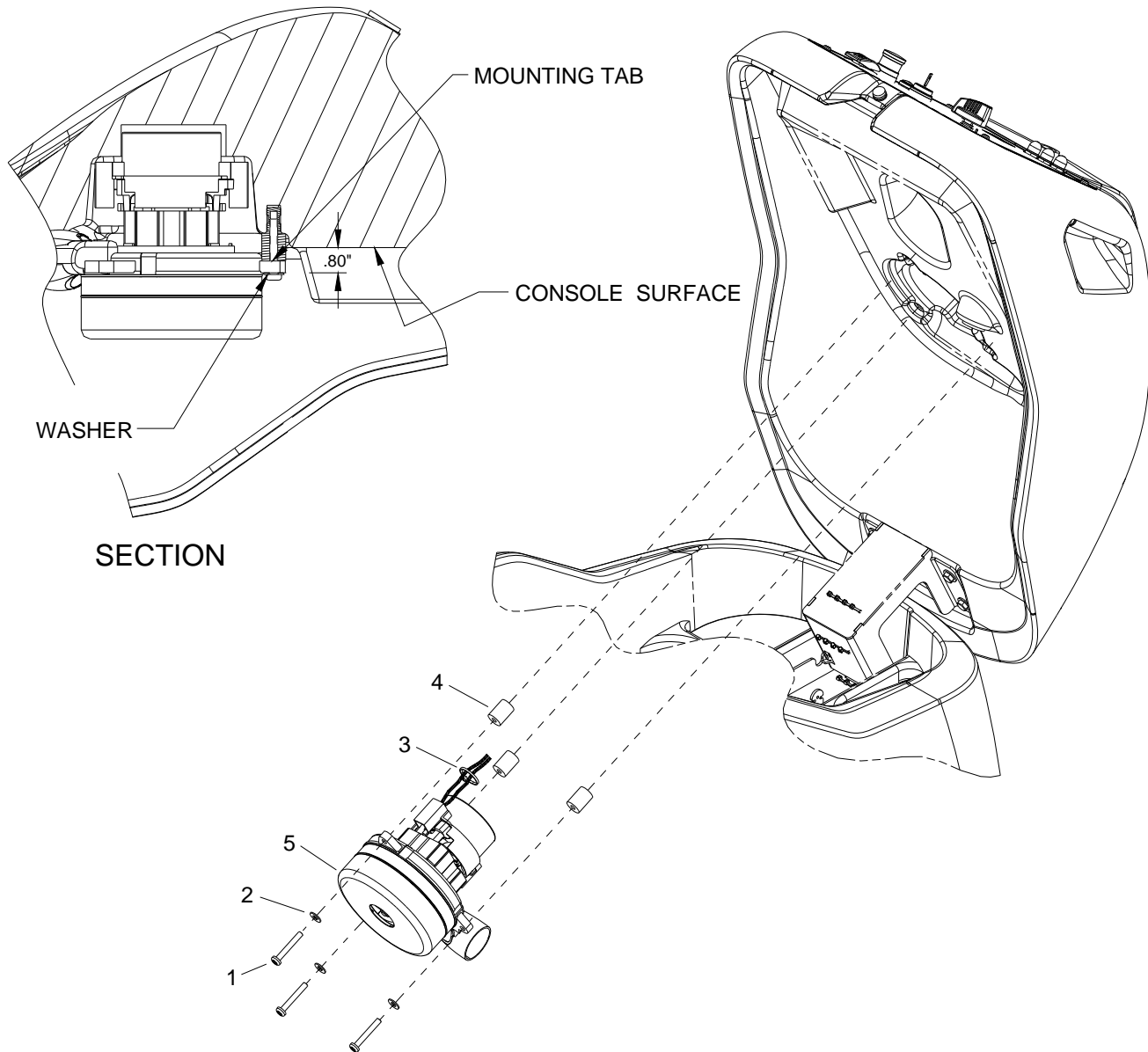

REF	PART NO.	PRV NO.	QTY	DESCRIPTION	SERIAL NO. FROM	NOTES
1	86273920	70049	3	SCREW, 1/4-20 X 1.75 PPHMS SS		
2	86010630	87013	3	WASHER 1/4 ID X 5/8 OD SS		
3	86264930	27050	1	CABLE TIE, 3.5" UL/CSA		
4	86327500	-	3	MOUNT, VIBRATION		
5	86012210	-	1	VAC MOTOR, 36VDC 2ST TD		
-	86135310	140686	1	BRUSH SET, 24/36V VAC, WINDSOR		

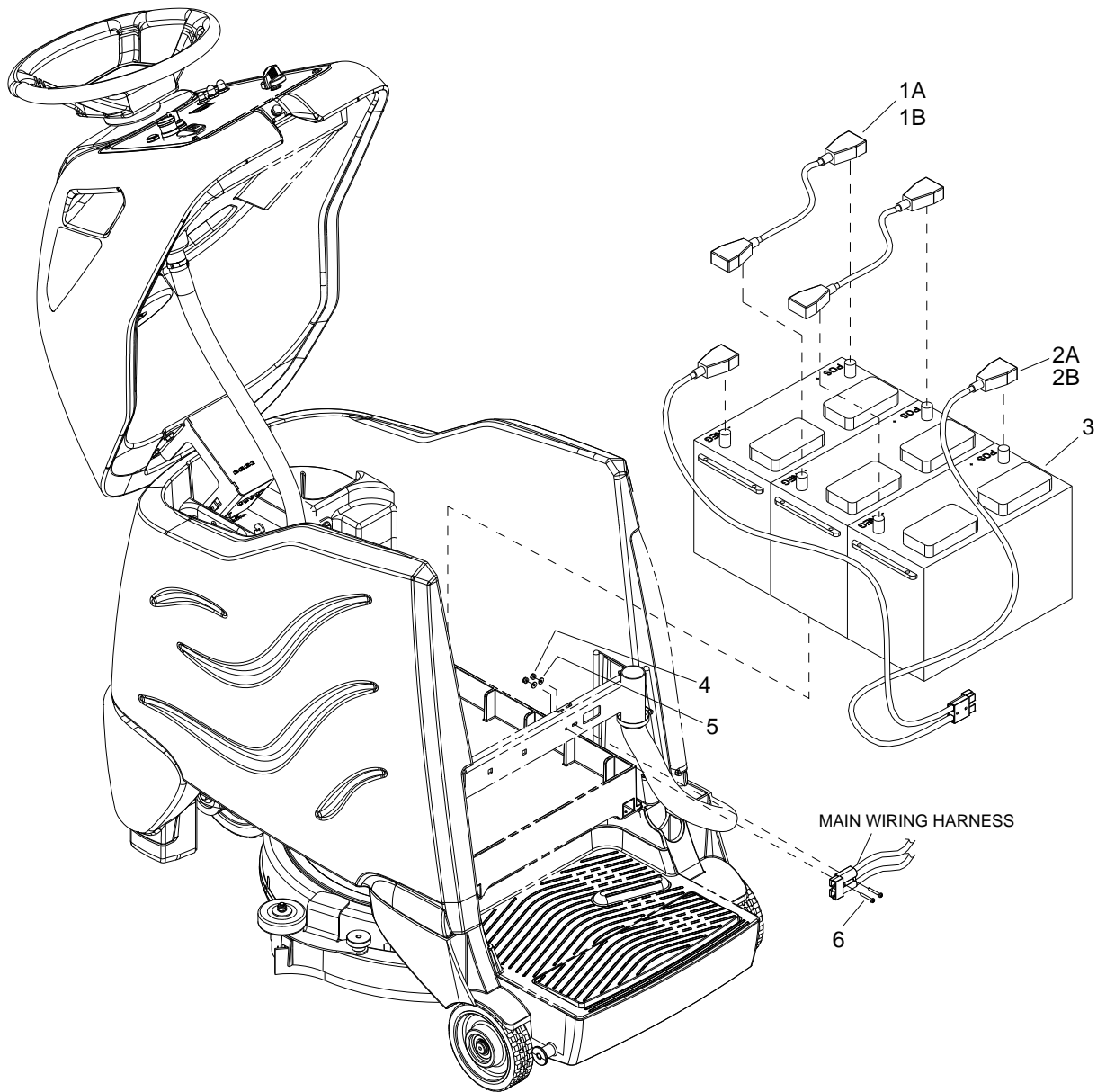

REF	PART NO.	PRV NO.	QTY	DESCRIPTION	SERIAL NO. FROM	NOTES
1A	86329720	-	2	BATT, CBL, ASM, JUMPER		
1B	86334280	-	2	CBL, 6GA 5/16" RING 15"		NOT SHOWN
2A	86329710	-	1	BATT,CBL,ASM,W/ANDERSON		
2B	86334270	-	1	CBL, BATT RING W/ANDERSON		NOT SHOWN
3	86228400	10021	3	BATTERY, 12V, 130AH		
-	86328630	-	3	BATTERY, 12V 114A/H AGM		NOT SHOWN
4	86270920	57049	2	SP NUT, 6-32 HEX NYLOCK SS		
5	86279450	87161	2	WASHER, #6 FLAT SAE PLTD		
6	86274710	70261	2	SCR, 6-32 X 1.0 PPHMS		
7	86271910	57295	6	NUT, 5/16-18 FLEXLOCK		NOT SHOWN
8	86006560	70083	6	SCREW 5/16-18 X 1 HHCS SS NP		NOT SHOWN

Wiring-Diagram -From Serial No. *(5)

X7	BRAKE Y1		1 - 15/RT 2 - 14/SW
X8	POT PLATFORM U2		1 - 19/BN 2 - 20/GE 3 - 18/OR 4 - 17/GN 5 - 16/BL 6 - NC
X9	TRACTION M3		1 - 21/RT 2 - 22/WS
X10	BRUSH M1		1 - 25/WS 2 - 26/SW
X11	ACTUATOR M4		1 - 3/WS 2 - 4/GE
X13	VACUUM M2		1 - 23/WS 2 - 24/SW
X12	MICRO SWITCH CONNECTOR S6,S9,S7,S10		1 - 1/BN 2 - 2/BL 3 - 13/RT 4 - NC 5 - 10/SW 6 - 9/VI 7 - 8/OR 8 - 7/GN
U1	INTERLOCK S5		1 - 11/WS 2 - 12/RT
X3	HORN H3	PANEL TB	5 - 5/WS 6 - 6/SW
X6	CHARGER OPTION		11C/SW 12C/RT

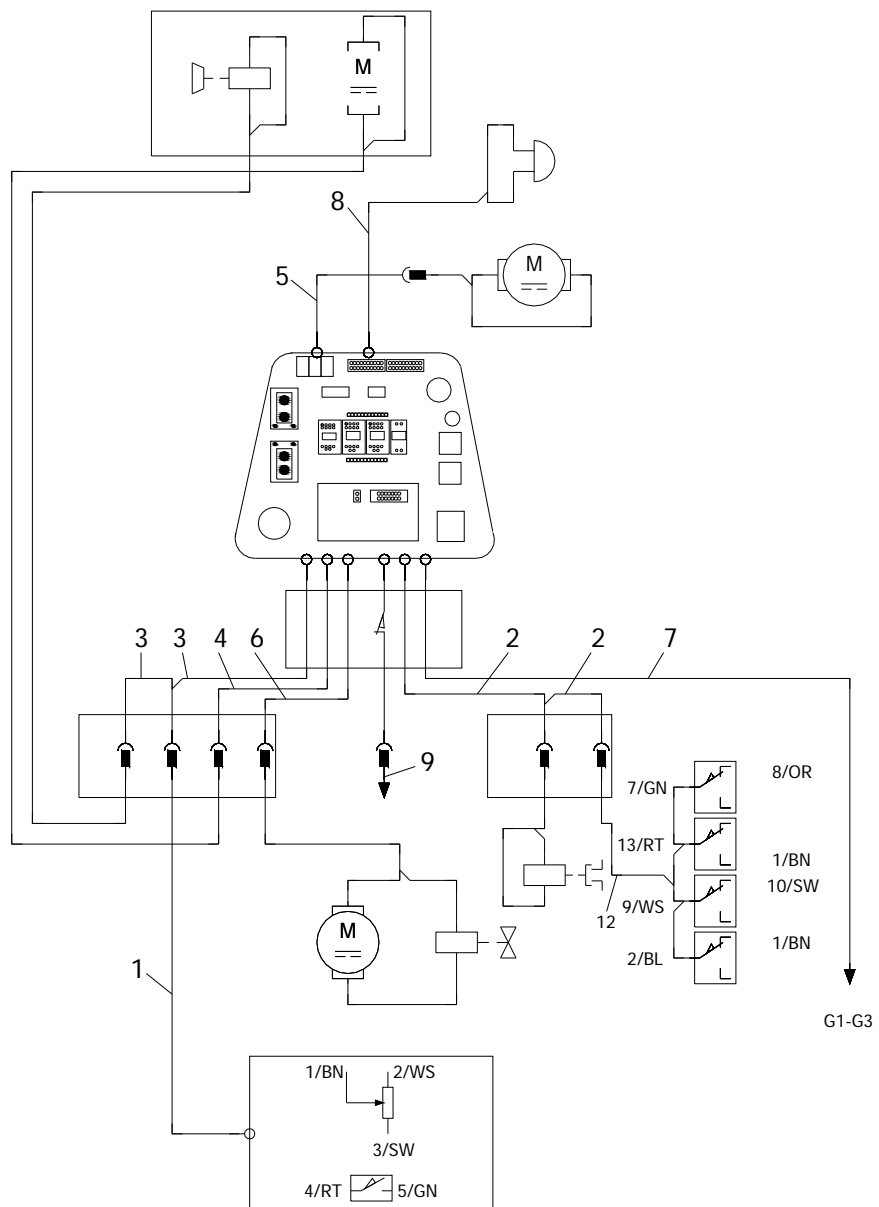

REF	PART NO.	PRV NO.	QTY	DESCRIPTION	SERIAL NO. FROM	NOTES
1	86326170	-	1	HARNESS, OPERATOR PLATFORM		
2	86333100	-	1	HARNESS, CS20 MAIN ACTUATOR		
3	86333110	-	1	HARNESS, CS20 MAIN POT AND BRAKE		
4	86333130	-	1	HARNESS, CS20 MAIN TRACTION		
5	86333140	-	1	HARNESS, CS20 MAIN VACUUM		
6	86333150	-	1	HARNESS, CS20 MAIN BRUSH		
7	86333160	-	1	HARNESS, CS20 MAIN POWER		
8	86333170	-	1	HARNESS, CS20 MAIN HORN		
9	86333180	-	1	JUMPER, CHARGER INHIBIT		

Wiring-Diagram-From Serial No. *(5)

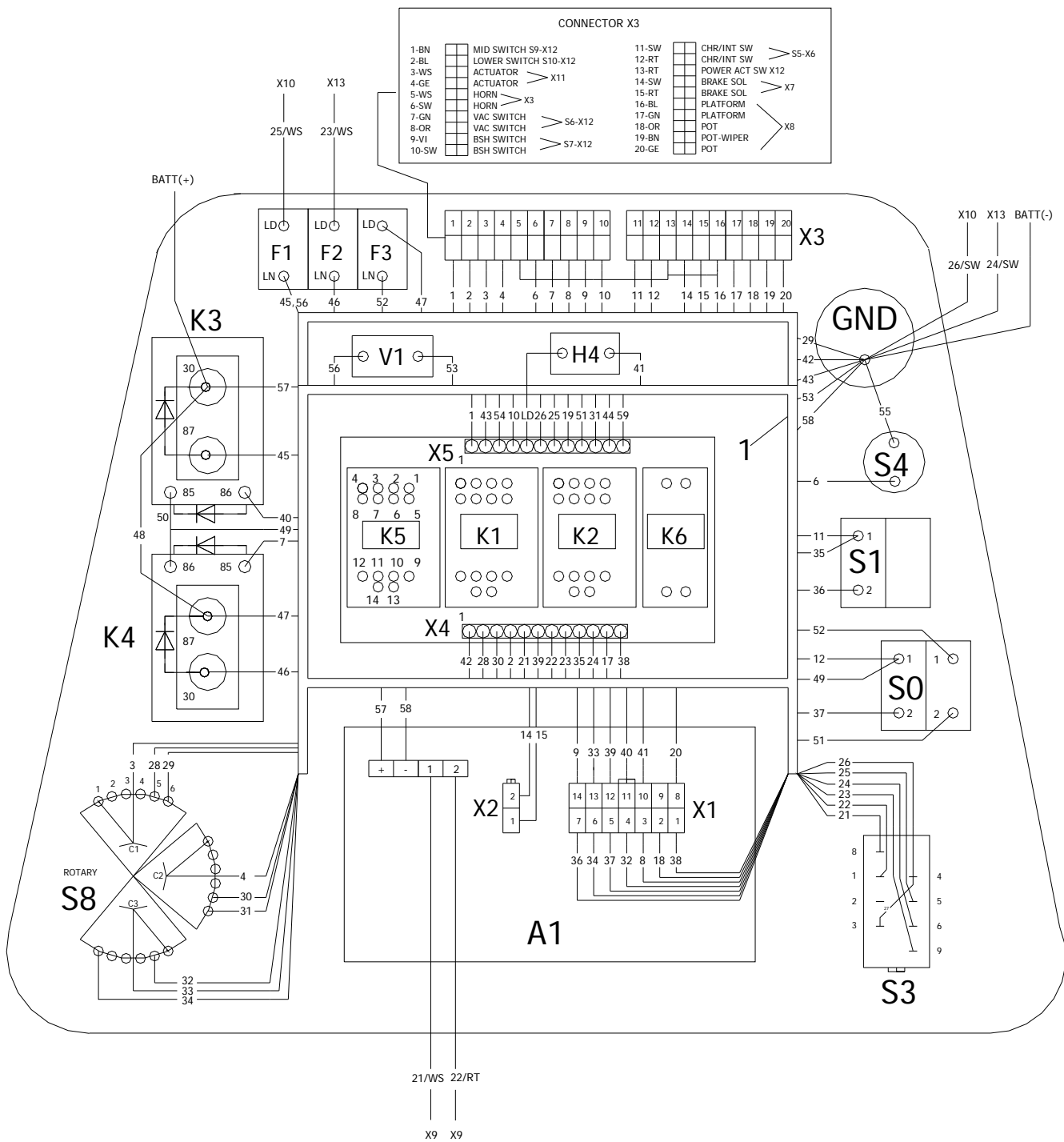

REF	PART NO.	PRV NO.	QTY	DESCRIPTION	SERIAL NO. FROM	NOTES
1	86338100	-	1	HARNESS, PANEL CS20		

REF	DESCRIPTION
F1	CIRCUIT BREAKER-BRUSH
F2	CIRCUIT BREAKER-VACUUM MOTOR
F3	CIRCUIT BREAKER-DRIVE CONTROL
G1-G3	BATTERY 12V/70Ah
H1	SIGNAL LAMPS REVERSE DIRECTION
H2	SIGNAL LAMPS DIRECTION FORWARD
H3	HORN
H4	LED-BATT.
K1	RELAYS-REVERSE DIRECTION
K2	RELAYS DIRECTION FORWARD
K3	RELAYS BRUSH MOTOR
K4	RELAYS VACUUM MOTOR
K5	REALYS ACTUATOR
K6	RELAYS MAIN
M1	BRUSH MOTOR
M3	TRACTION MOTOR
M4	LINEAR ACTUATOR MOTOR BRUSH/SQUEEGEE
S0	EMERGENCY SWITCH
S1	KEYSWITCH
S2	MICROSWITCH-PLATFORM
S3	BUTTON REVERSE FORWARD
S4	HORN BUTTON
S5	MICROSWITCH-COVER
S6	MIRCOSWITCH-VACUUM
S7	MICROSWITCH-BRUSH
S8	PROGRAM SWITCH
S9	MICROSWITCH-MID
S10	MIRCROSWITCH-LOWER
S11	CHARGER
S-UP-SDOWN	MICROSWITCH
P1	HOURS METER
V1-V2-V3-V4-V5-V6-V7-V8-V9	DIODE
V-UP & V-DOWN	DIODE-MOTOR M4
X3	TERMINAL BLOCK
FRAME X1-X2-X3-X4-X5-X6-X7	PLUG AND SOCKET
FRAME 8X-X9-X10-X11-X12	PLUG AND SOCKET
Y1	BRAKE
Y2	ELECTOVALVE WATER

Wiring-Diagram -From Serial No. *(5)

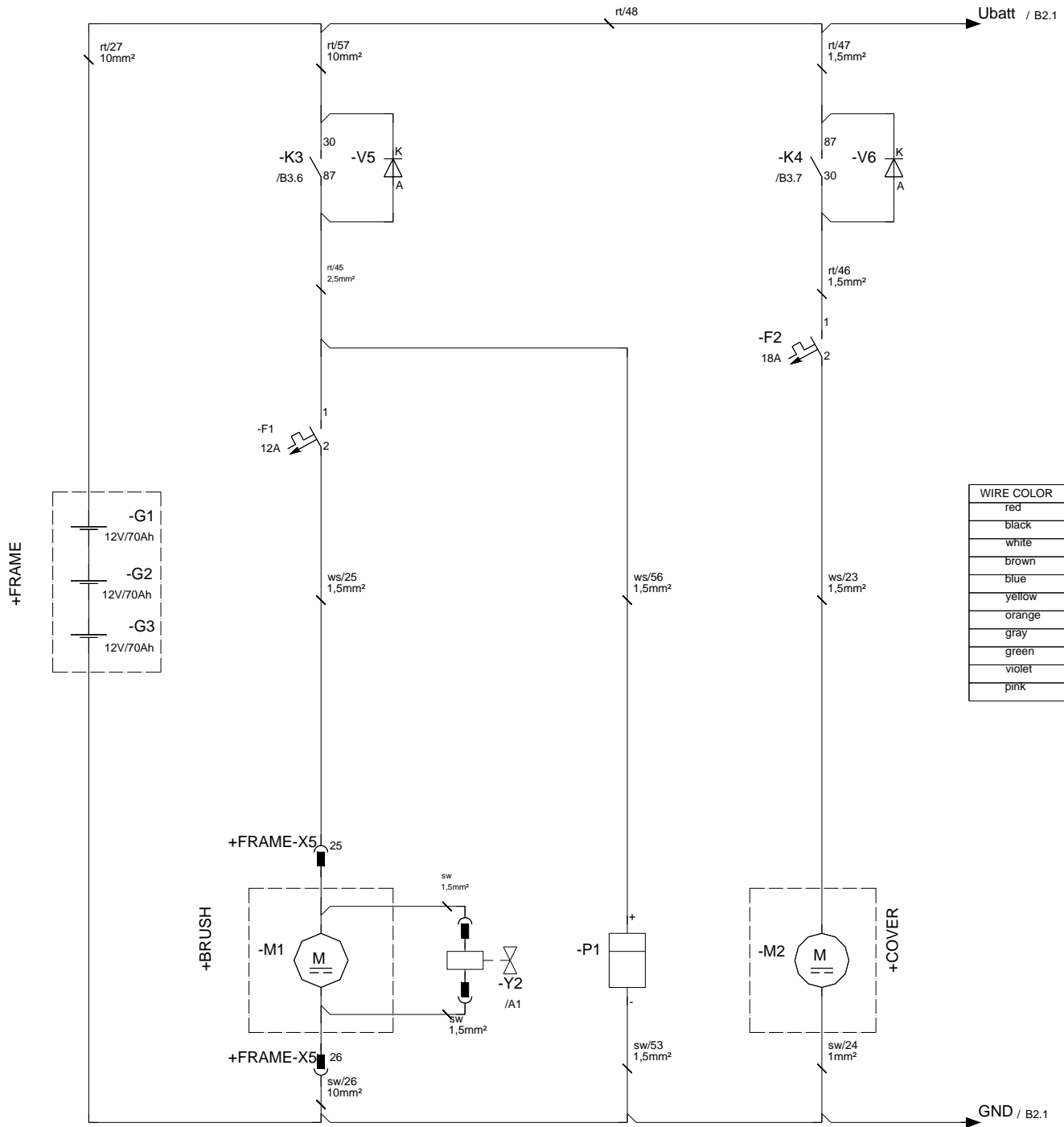

REF	DESCRIPTION
F1	CIRCUIT BREAKER-BRUSH
F2	CIRCUIT BREAKER-VACUUM MOTOR
F3	CIRCUIT BREAKER-DRIVE CONTROL
G1-G3	BATTERY 12V/70Ah
H1	SIGNAL LAMPS REVERSE DIRECTION
H2	SIGNAL LAMPS DIRECTION FORWARD
H3	HORN
H4	LED-BATT.
K1	RELAYS-REVERSE DIRECTION
K2	RELAYS DIRECTION FORWARD
K3	RELAYS BRUSH MOTOR
K4	RELAYS VACUUM MOTOR
K5	REALYS ACTUATOR
K6	RELAYS MAIN
M1	BRUSH MOTOR
M3	TRACTION MOTOR
M4	LINEAR ACTUATOR MOTOR BRUSH/SQUEEGEE
S0	EMERGENCY SWITCH
S1	KEYSWITCH
S2	MICROSWITCH-PLATFORM
S3	BUTTON REVERSE FORWARD
S4	HORN BUTTON
S5	MICROSWITCH-COVER
S6	MIRCOSWITCH-VACUUM
S7	MICROSWITCH-BRUSH
S8	PROGRAM SWITCH
S9	MICROSWITCH-MID
S10	MIRCROSWITCH-LOWER
S11	CHARGER
S-UP-SDOWN	MICROSWITCH
P1	HOURS METER
V1-V2-V3-V4-V5-V6-V7-V8-V9	DIODE
V-UP & V-DOWN	DIODE-MOTOR M4
X3	TERMINAL BLOCK
FRAME X1-X2-X3-X4-X5-X6-X7	PLUG AND SOCKET
FRAME 8X-X9-X10-X11-X12	PLUG AND SOCKET
Y1	BRAKE
Y2	ELECTOVALVE WATER

Wiring-Diagram -From Serial No. *(5)

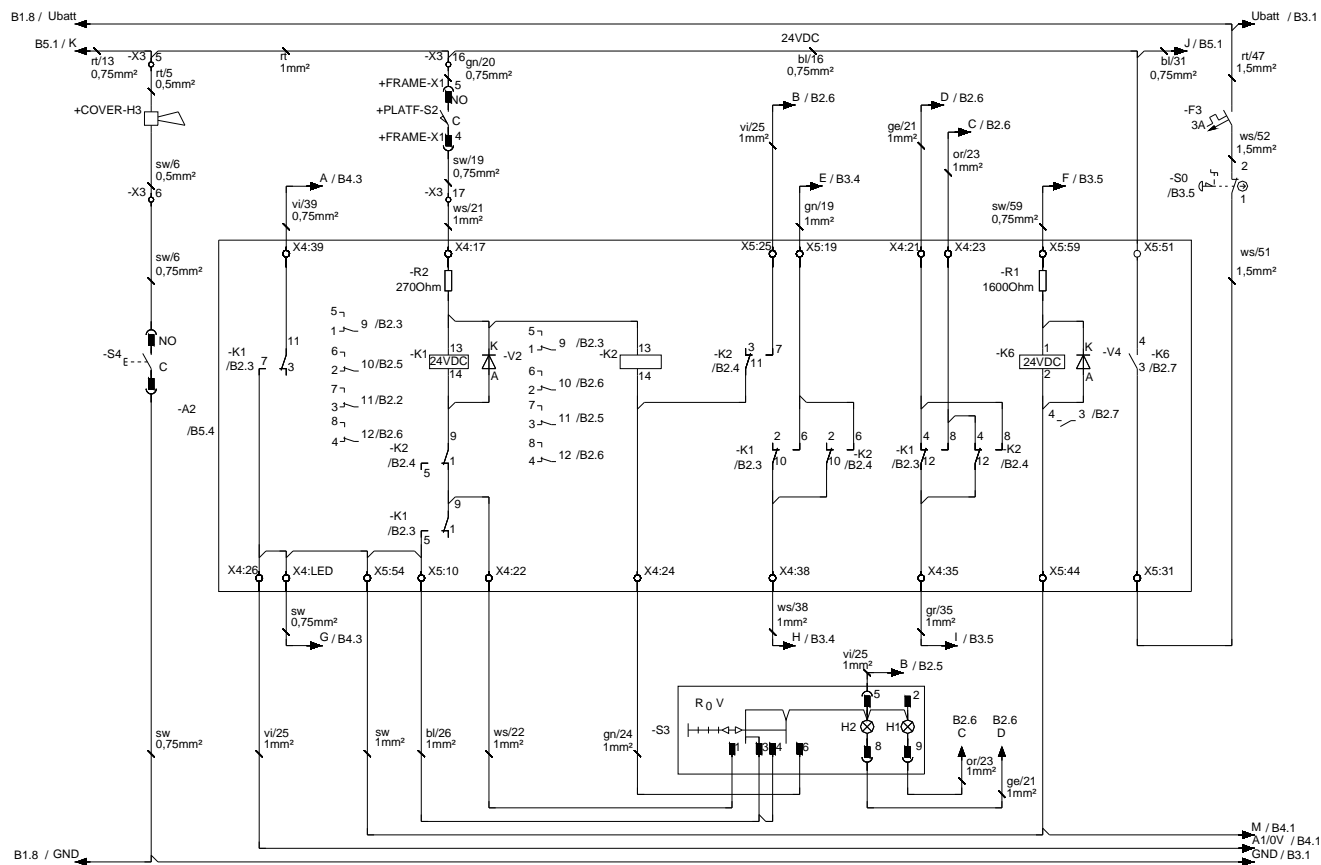

REF	DESCRIPTION
F1	CIRCUIT BREAKER-BRUSH
F2	CIRCUIT BREAKER-VACUUM MOTOR
F3	CIRCUIT BREAKER-DRIVE CONTROL
G1-G3	BATTERY 12V/70Ah
H1	SIGNAL LAMPS REVERSE DIRECTION
H2	SIGNAL LAMPS DIRECTION FORWARD
H3	HORN
H4	LED-BATT.
K1	RELAYS-REVERSE DIRECTION
K2	RELAYS DIRECTION FORWARD
K3	RELAYS BRUSH MOTOR
K4	RELAYS VACUUM MOTOR
K5	REALYS ACTUATOR
K6	RELAYS MAIN
M1	BRUSH MOTOR
M3	TRACTION MOTOR
M4	LINEAR ACTUATOR MOTOR BRUSH/SQUEEGEE
S0	EMERGENCY SWITCH
S1	KEYSWITCH
S2	MICROSWITCH-PLATFORM
S3	BUTTON REVERSE FORWARD
S4	HORN BUTTON
S5	MICROSWITCH-COVER
S6	MIRCOSWITCH-VACUUM
S7	MICROSWITCH-BRUSH
S8	PROGRAM SWITCH
S9	MICROSWITCH-MID
S10	MIRCROSWITCH-LOWER
S11	CHARGER
S-UP-SDOWN	MICROSWITCH
P1	HOURS METER
V1-V2-V3-V4-V5-V6-V7-V8-V9	DIODE
V-UP & V-DOWN	DIODE-MOTOR M4
X3	TERMINAL BLOCK
FRAME X1-X2-X3-X4-X5-X6-X7	PLUG AND SOCKET
FRAME 8X-X9-X10-X11-X12	PLUG AND SOCKET
Y1	BRAKE
Y2	ELECTOVALVE WATER

Wiring-Diagram -From Serial No. *(5)

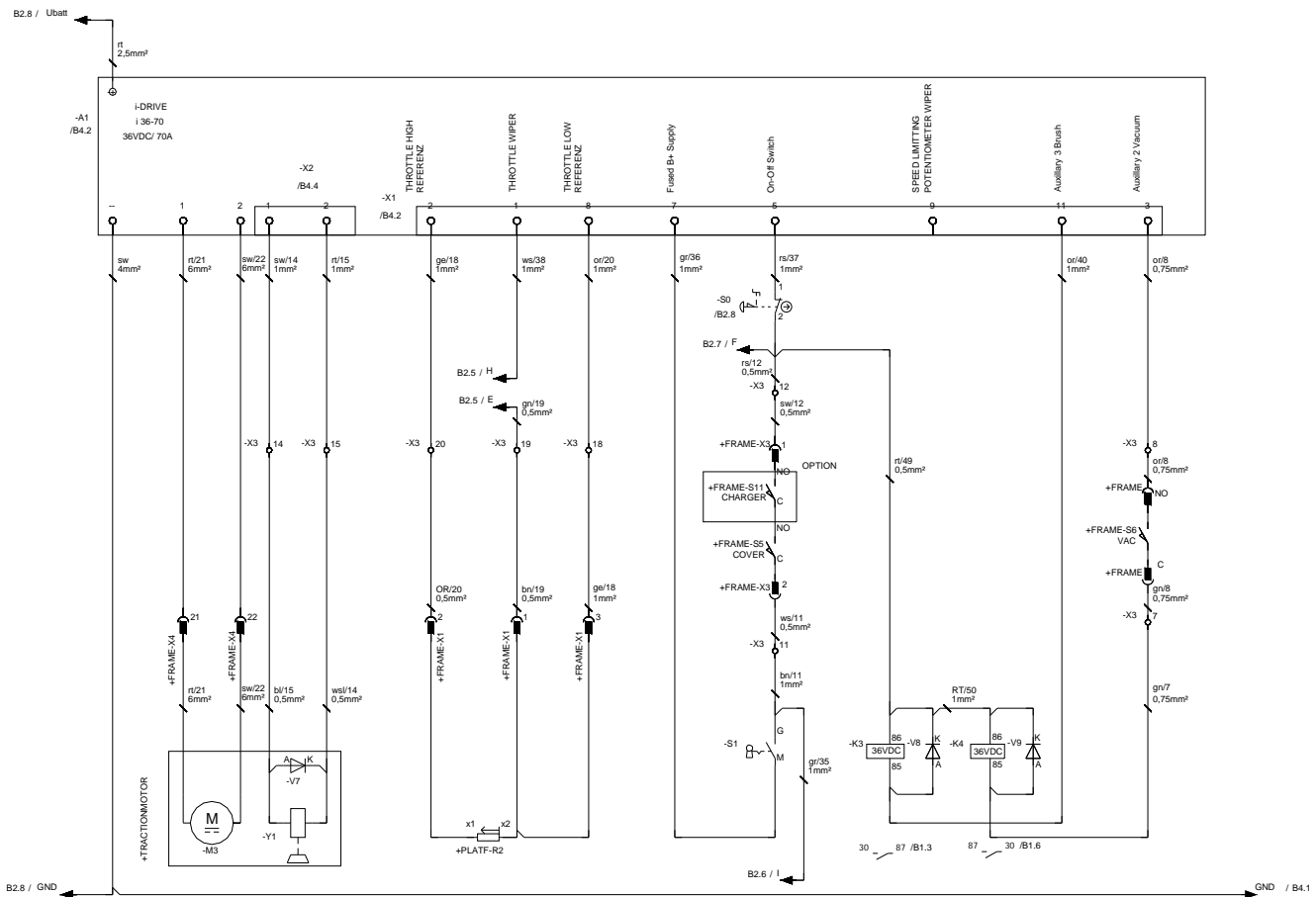

REF	DESCRIPTION
F1	CIRCUIT BREAKER-BRUSH
F2	CIRCUIT BREAKER-VACUUM MOTOR
F3	CIRCUIT BREAKER-DRIVE CONTROL
G1-G3	BATTERY 12V/70Ah
H1	SIGNAL LAMPS REVERSE DIRECTION
H2	SIGNAL LAMPS DIRECTION FORWARD
H3	HORN
H4	LED-BATT.
K1	RELAYS-REVERSE DIRECTION
K2	RELAYS DIRECTION FORWARD
K3	RELAYS BRUSH MOTOR
K4	RELAYS VACUUM MOTOR
K5	REALYS ACTUATOR
K6	RELAYS MAIN
M1	BRUSH MOTOR
M3	TRACTION MOTOR
M4	LINEAR ACTUATOR MOTOR BRUSH/SQUEEGEE
S0	EMERGENCY SWITCH
S1	KEYSWITCH
S2	MICROSWITCH-PLATFORM
S3	BUTTON REVERSE FORWARD
S4	HORN BUTTON
S5	MICROSWITCH-COVER
S6	MIRCOSWITCH-VACUUM
S7	MICROSWITCH-BRUSH
S8	PROGRAM SWITCH
S9	MICROSWITCH-MID
S10	MIRCROSWITCH-LOWER
S11	CHARGER
S-UP-SDOWN	MICROSWITCH
P1	HOURS METER
V1-V2-V3-V4-V5-V6-V7-V8-V9	DIODE
V-UP & V-DOWN	DIODE-MOTOR M4
X3	TERMINAL BLOCK
FRAME X1-X2-X3-X4-X5-X6-X7	PLUG AND SOCKET
FRAME 8X-X9-X10-X11-X12	PLUG AND SOCKET
Y1	BRAKE
Y2	ELECTOVALVE WATER

Wiring-Diagram -From Serial No. *(5)

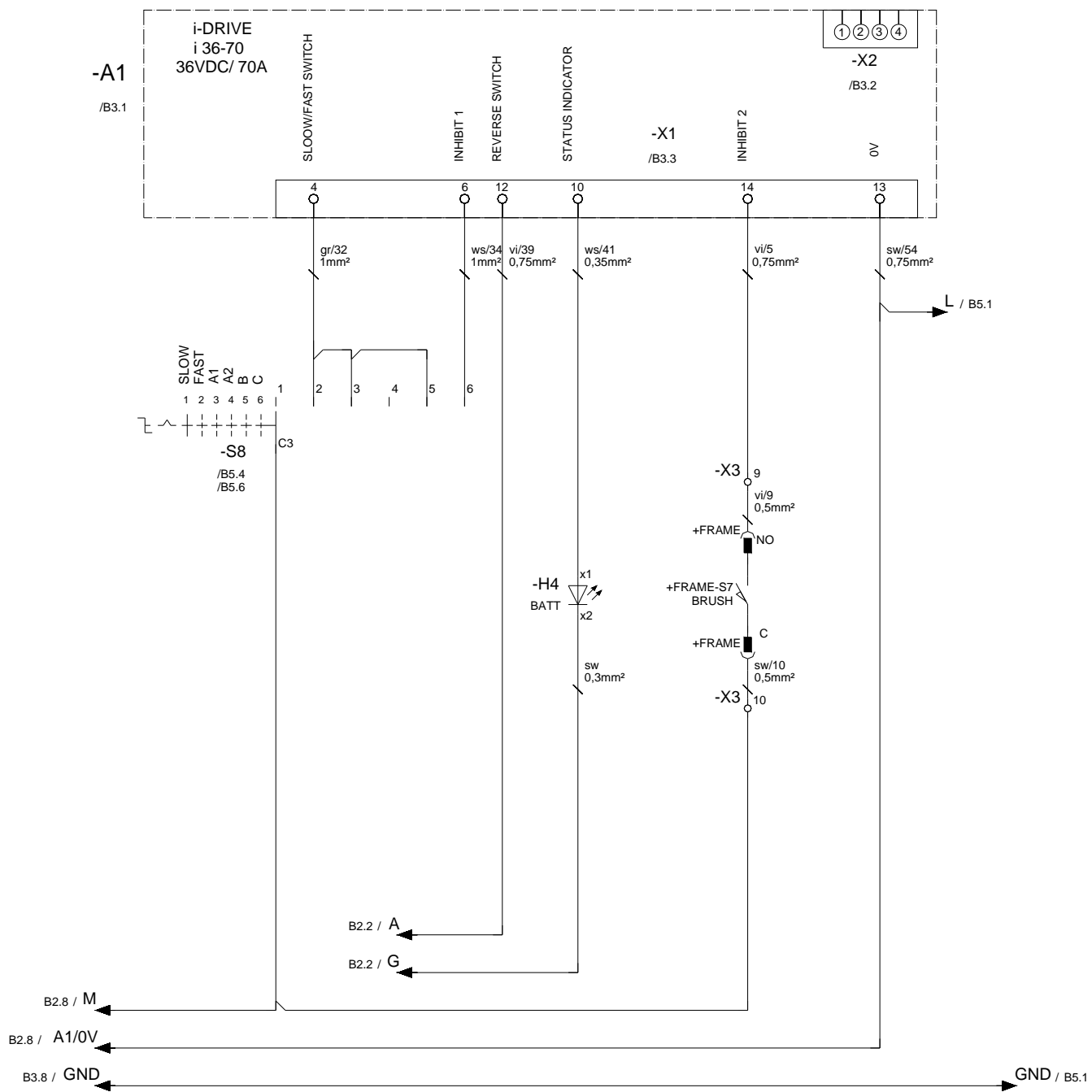

REF	DESCRIPTION
F1	CIRCUIT BREAKER-BRUSH
F2	CIRCUIT BREAKER-VACUUM MOTOR
F3	CIRCUIT BREAKER-DRIVE CONTROL
G1-G3	BATTERY 12V/70Ah
H1	SIGNAL LAMPS REVERSE DIRECTION
H2	SIGNAL LAMPS DIRECTION FORWARD
H3	HORN
H4	LED-BATT.
K1	RELAYS-REVERSE DIRECTION
K2	RELAYS DIRECTION FORWARD
K3	RELAYS BRUSH MOTOR
K4	RELAYS VACUUM MOTOR
K5	REALYS ACTUATOR
K6	RELAYS MAIN
M1	BRUSH MOTOR
M3	TRACTION MOTOR
M4	LINEAR ACTUATOR MOTOR BRUSH/SQUEEGEE
S0	EMERGENCY SWITCH
S1	KEYSWITCH
S2	MICROSWITCH-PLATFORM
S3	BUTTON REVERSE FORWARD
S4	HORN BUTTON
S5	MICROSWITCH-COVER
S6	MIRCOSWITCH-VACUUM
S7	MICROSWITCH-BRUSH
S8	PROGRAM SWITCH
S9	MICROSWITCH-MID
S10	MIRCROSWITCH-LOWER
S11	CHARGER
S-UP-SDOWN	MICROSWITCH
P1	HOURS METER
V1-V2-V3-V4-V5-V6-V7-V8-V9	DIODE
V-UP & V-DOWN	DIODE-MOTOR M4
X3	TERMINAL BLOCK
FRAME X1-X2-X3-X4-X5-X6-X7	PLUG AND SOCKET
FRAME 8X-X9-X10-X11-X12	PLUG AND SOCKET
Y1	BRAKE
Y2	ELECTOVALVE WATER

Wiring-Diagram -From Serial No. *(5)

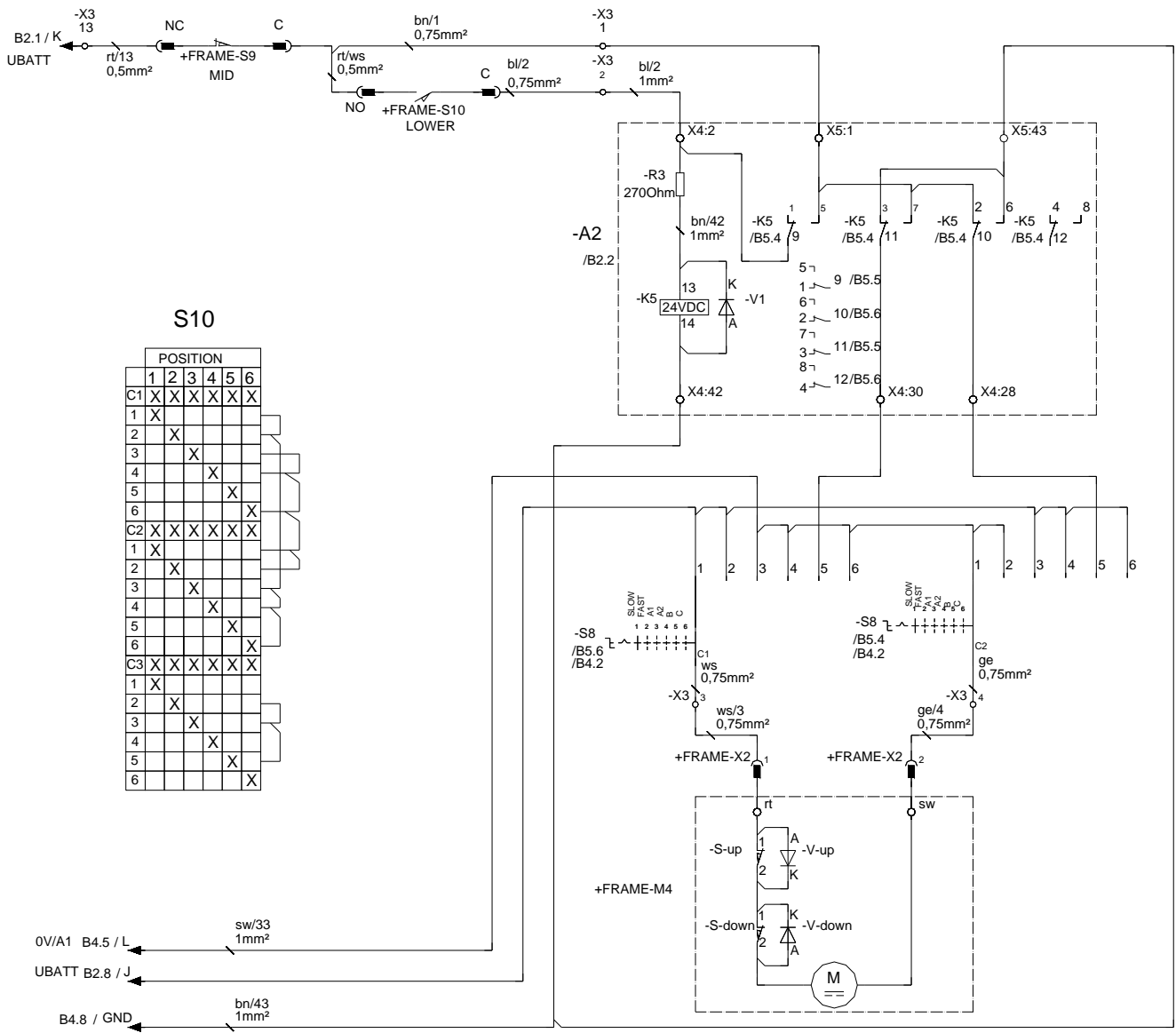

REF	DESCRIPTION
F1	CIRCUIT BREAKER-BRUSH
F2	CIRCUIT BREAKER-VACUUM MOTOR
F3	CIRCUIT BREAKER-DRIVE CONTROL
G1-G3	BATTERY 12V/70Ah
H1	SIGNAL LAMPS REVERSE DIRECTION
H2	SIGNAL LAMPS DIRECTION FORWARD
H3	HORN
H4	LED-BATT.
K1	RELAYS-REVERSE DIRECTION
K2	RELAYS DIRECTION FORWARD
K3	RELAYS BRUSH MOTOR
K4	RELAYS VACUUM MOTOR
K5	REALYS ACTUATOR
K6	RELAYS MAIN
M1	BRUSH MOTOR
M3	TRACTION MOTOR
M4	LINEAR ACTUATOR MOTOR BRUSH/SQUEEGEE
S0	EMERGENCY SWITCH
S1	KEYSWITCH
S2	MICROSWITCH-PLATFORM
S3	BUTTON REVERSE FORWARD
S4	HORN BUTTON
S5	MICROSWITCH-COVER
S6	MIRCOSWITCH-VACUUM
S7	MICROSWITCH-BRUSH
S8	PROGRAM SWITCH
S9	MICROSWITCH-MID
S10	MIRCROSWITCH-LOWER
S11	CHARGER
S-UP-SDOWN	MICROSWITCH
P1	HOURS METER
V1-V2-V3-V4-V5-V6-V7-V8-V9	DIODE
V-UP & V-DOWN	DIODE-MOTOR M4
X3	TERMINAL BLOCK
FRAME X1-X2-X3-X4-X5-X6-X7	PLUG AND SOCKET
FRAME 8X-X9-X10-X11-X12	PLUG AND SOCKET
Y1	BRAKE
Y2	ELECTOVALVE WATER

FRONT

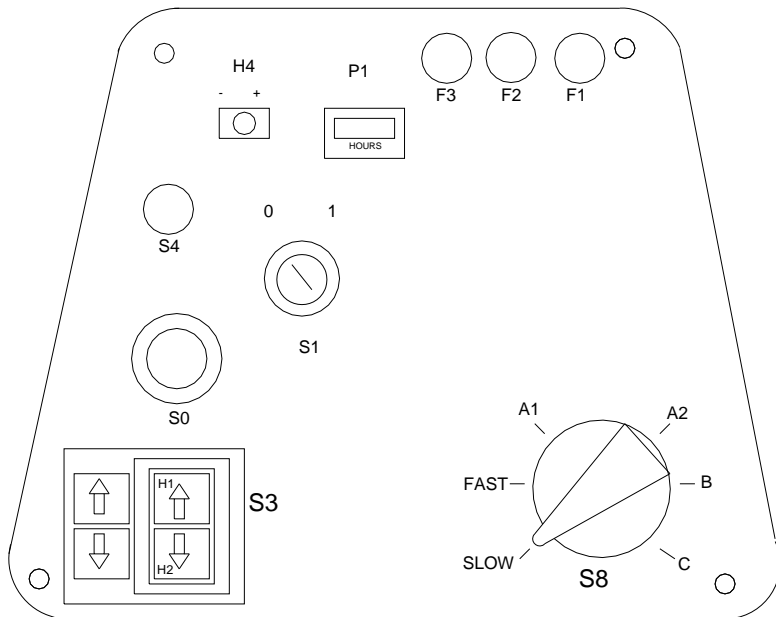

BACK

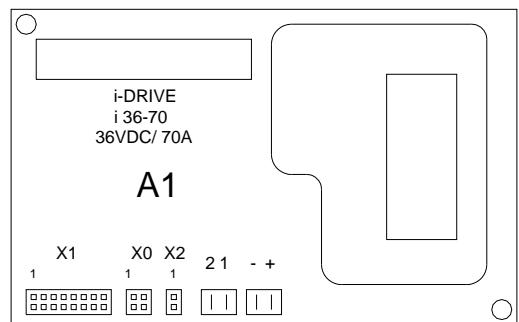
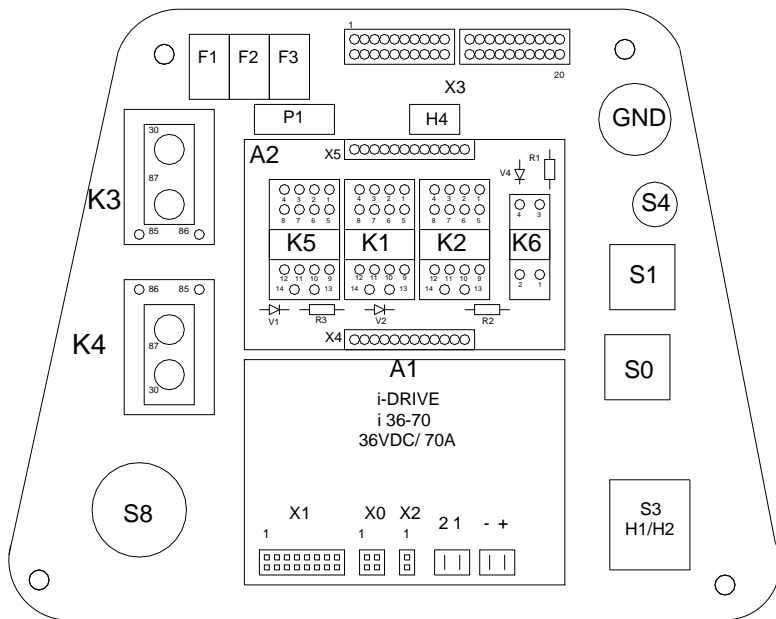

REF	DESCRIPTION
F1	CIRCUIT BREAKER-BRUSH
F2	CIRCUIT BREAKER-VACUUM MOTOR
F3	CIRCUIT BREAKER-DRIVE CONTROL
G1-G3	BATTERY 12V/70Ah
H1	SIGNAL LAMPS REVERSE DIRECTION
H2	SIGNAL LAMPS DIRECTION FORWARD
H3	HORN
H4	LED-BATT.
K1	RELAYS-REVERSE DIRECTION
K2	RELAYS DIRECTION FORWARD
K3	RELAYS BRUSH MOTOR
K4	RELAYS VACUUM MOTOR
K5	REALYS ACTUATOR
K6	RELAYS MAIN
M1	BRUSH MOTOR
M3	TRACTION MOTOR
M4	LINEAR ACTUATOR MOTOR BRUSH/SQUEEGEE
S0	EMERGENCY SWITCH
S1	KEYSWITCH
S2	MICROSWITCH-PLATFORM
S3	BUTTON REVERSE FORWARD
S4	HORN BUTTON
S5	MICROSWITCH-COVER
S6	MIRCOSWITCH-VACUUM
S7	MICROSWITCH-BRUSH
S8	PROGRAM SWITCH
S9	MICROSWITCH-MID
S10	MIRCROSWITCH-LOWER
S11	CHARGER
S-UP-SDOWN	MICROSWITCH
P1	HOURS METER
V1-V2-V3-V4-V5-V6-V7-V8-V9	DIODE
V-UP & V-DOWN	DIODE-MOTOR M4
X3	TERMINAL BLOCK
FRAME X1-X2-X3-X4-X5-X6-X7	PLUG AND SOCKET
FRAME 8X-X9-X10-X11-X12	PLUG AND SOCKET
Y1	BRAKE
Y2	ELECTOVALVE WATER

Wiring-Control Panel -Prior to Serial No. *(5)

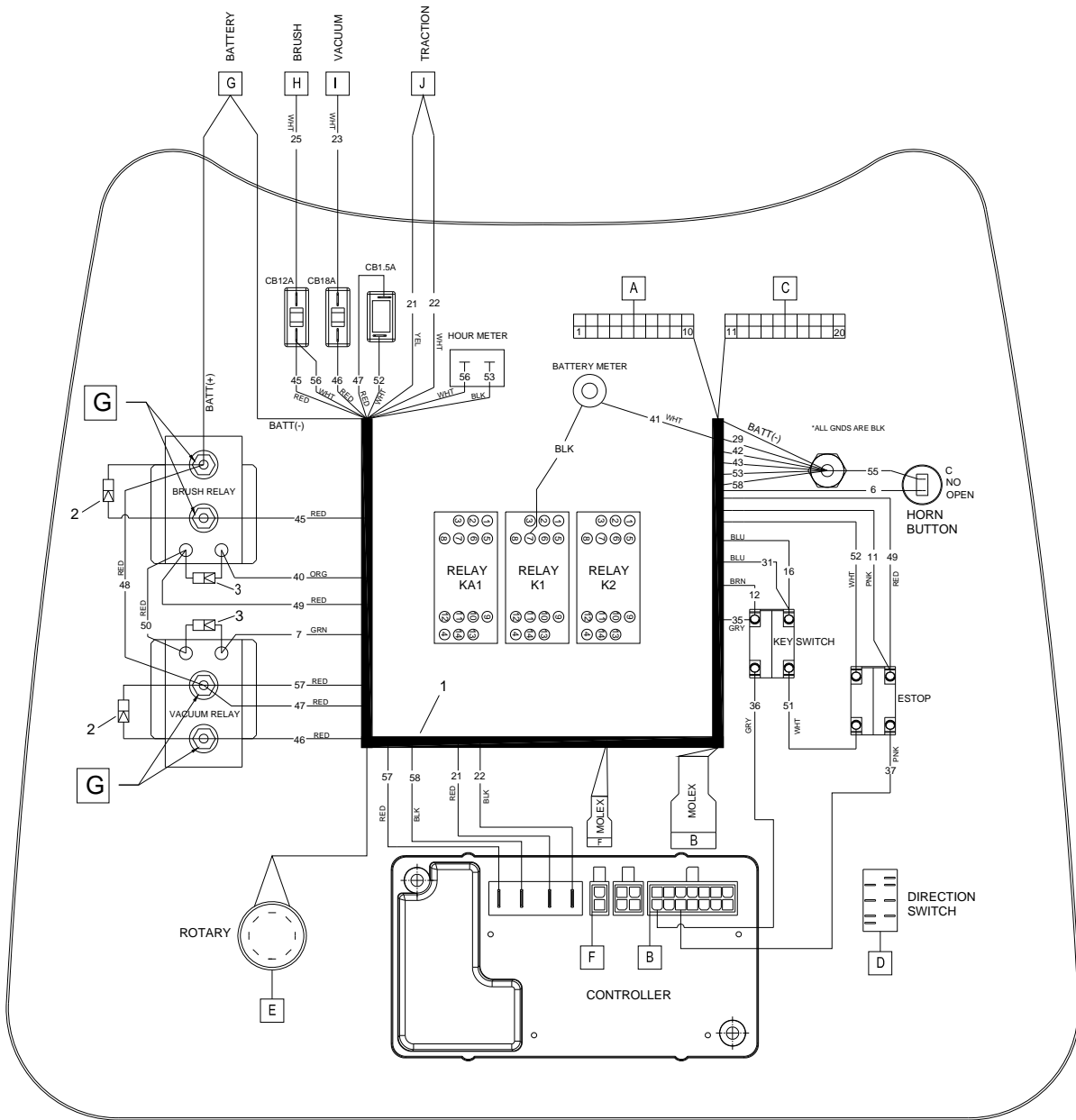

- RELAY JUMPERS**
 PIN 5 K1-PIN 7 K1
 PIN 6 K1-PIN 6 K2
 PIN 8 K1-PIN 4 K2
 PIN 9 K1-PIN 1 K2
 PIN 4 K1-PIN 8 K2
 PIN 10 K1-PIN 10 K2
 PIN 12 K1-PIN 12 K2
 PIN 13 K1-PIN 13 K2
 PIN 14 K1-PIN 9 K2
 PIN 11 K2-PIN 14 K2
- RELAY JUMPERS**
 PIN 2 KA1-PIN 7 KA1
 PIN 3 KA1-PIN 6 KA1
 PIN 2 KA1-PIN 5 KA1
- RESISTOR 2700HM 5W**
 PIN 9 KA1-PIN 13 KA1
 PIN 13 K2-PIN 17 TB

CONNECTOR A

1-BRN	MID SWITCH S1
2-BLU	LOWER SWITCH S2
3-WHT	ACTUATOR
4-YEL	ACTUATOR
5-WHT	HORN
6-BLK	HORN
7-GRN	VAC SWITCH
8-ORG	VAC SWITCH
9-VIO	BSH SWITCH
10-BLK	BSH SWITCH

CONNECTOR B

1	4	3	2	1
4	1	2	3	4

4 PIN 1

PIN 1 - 38-WHT
PIN 2 - 18-YEL
PIN 3 - 8-ORG
PIN 4 - 32-GRY
PIN 5 - 37-PNK
PIN 6 - 34-WHT
PIN 7 - 36-GRY
PIN 8 - 20-ORG
PIN 10 - 41-YEL
PIN 11 - 40-ORG
PIN 12 - 39-VIO
PIN 13 - 33-BLK
PIN 14 - 9-VIO

CONNECTOR C

11-BLK	CHR/INT SWITCH
12-WHT	CHR/INT SWITCH
13-RED	POWER ACT SWITCHES
14-BLK	BRAKE SOL
15-RED	BRAKE SOL
16-BLU	PLATFORM
17-GRN	PLATFORM
18-YEL	POT
19-BRN	POT-WIPER
20-ORG	POT

CONNECTOR D

1	2	3	4	5	6	7	8	9
---	---	---	---	---	---	---	---	---

S1 - PIN 9 K1 / 22-WHT
S2 - OPEN
S3 - S4 / 27-BLK
S4 - PIN 5 K1 / 26-BLU
S5 - PIN 7 K2 / 25-VIO
S6 - PIN 14 K2 / 24-GRN
S8 - PIN 4 K1 / 21-YEL
S9 - PIN 4 K2 / 23-ORG

CONNECTOR F

2	1
---	---

PIN 2 - BRAKE NEGATIVE
 PIN 1 - BRAKE POSITIVE

CONNECTOR E

ROTARY JUMPERS

C1-1 TO C1-2
C1-2 TO C2-3
C2-3 TO C2-4
C2-4 TO C2-6
C2-1 TO C2-2
C2-2 TO C1-3
C1-3 TO C1-4
C1-4 TO C1-6
C3-2 TO C3-3
C3-3 TO C3-5

G TORQUE 45-55 IN-LBS

REF	PART NO.	PRV NO.	QTY	DESCRIPTION	SERIAL NO. FROM	NOTES
1	86326190	-	1	HARNESS, MAIN PANEL		
2	86261210	29204	2	DIODE ASM, 76008 X 76008		
3	86003410	29215	2	DIODE ASM, 76075 X 76075		

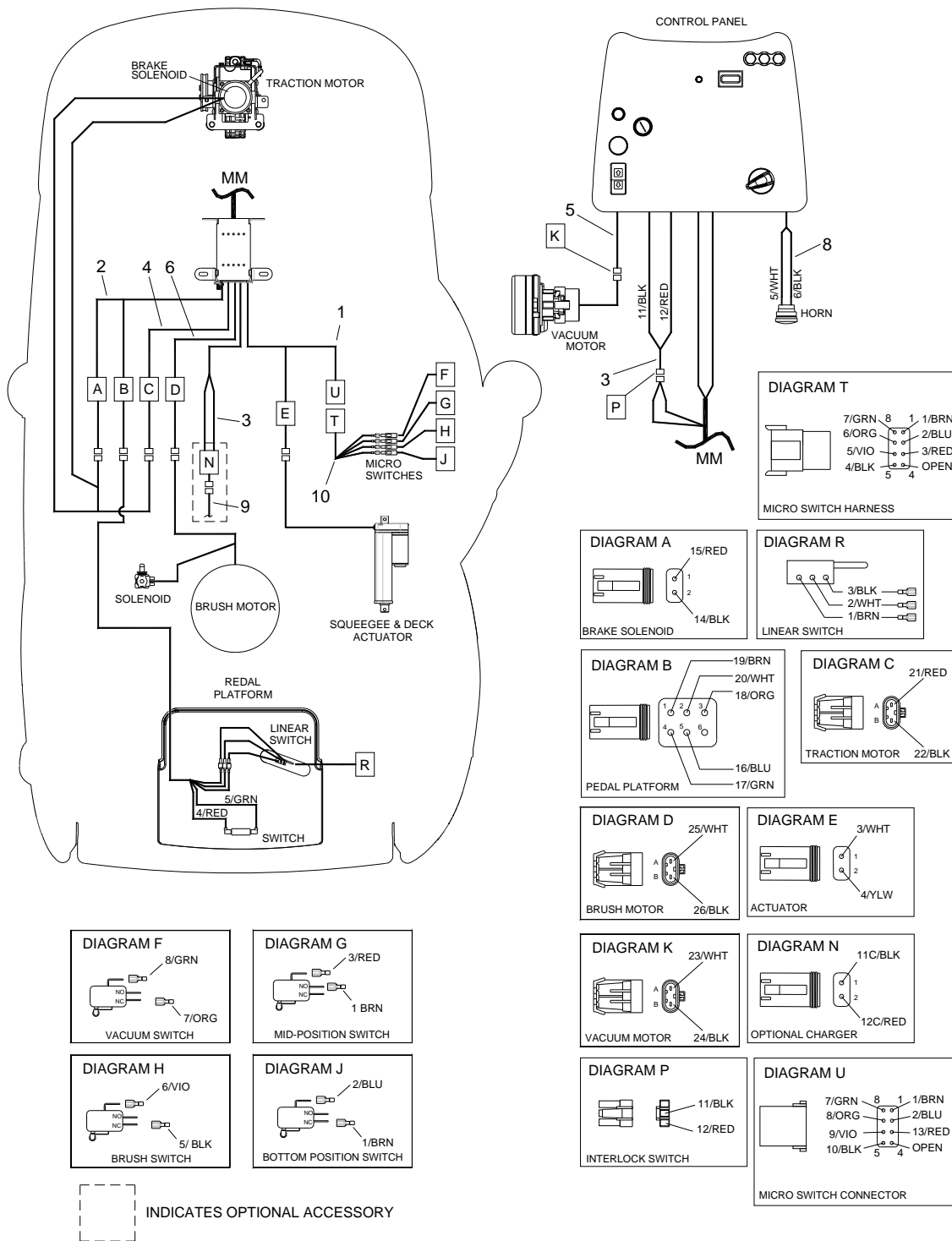

REF	PART NO.	PRV NO.	QTY	DESCRIPTION	SERIAL NO. FROM	NOTES
1	86333100	-	1	HARNESS, CS20 MAIN ACTUATOR		
2	86333110	-	1	HARNESS, CS20 MAIN POT AND BRAKE		
3	86333120	-	1	HARNESS, CS20 MAIN CHARGER		
4	86333130	-	1	HARNESS, CS20 MAIN TRACTION		
5	86333140	-	1	HARNESS, CS20 MAIN VACUUM		
6	86333150	-	1	HARNESS, CS20 MAIN BRUSH		
7	86333160	-	1	HARNESS, CS20 MAIN POWER		
8	86333170	-	1	HARNESS, CS20 MAIN HORN		
9	86333180	-	1	JUMPER, CHARGER INHIBIT		
10	86333400	-	1	HARNESS, CS20 MICRO SWITCH		

Wiring-Diagram -Prior to Serial No. *(5)

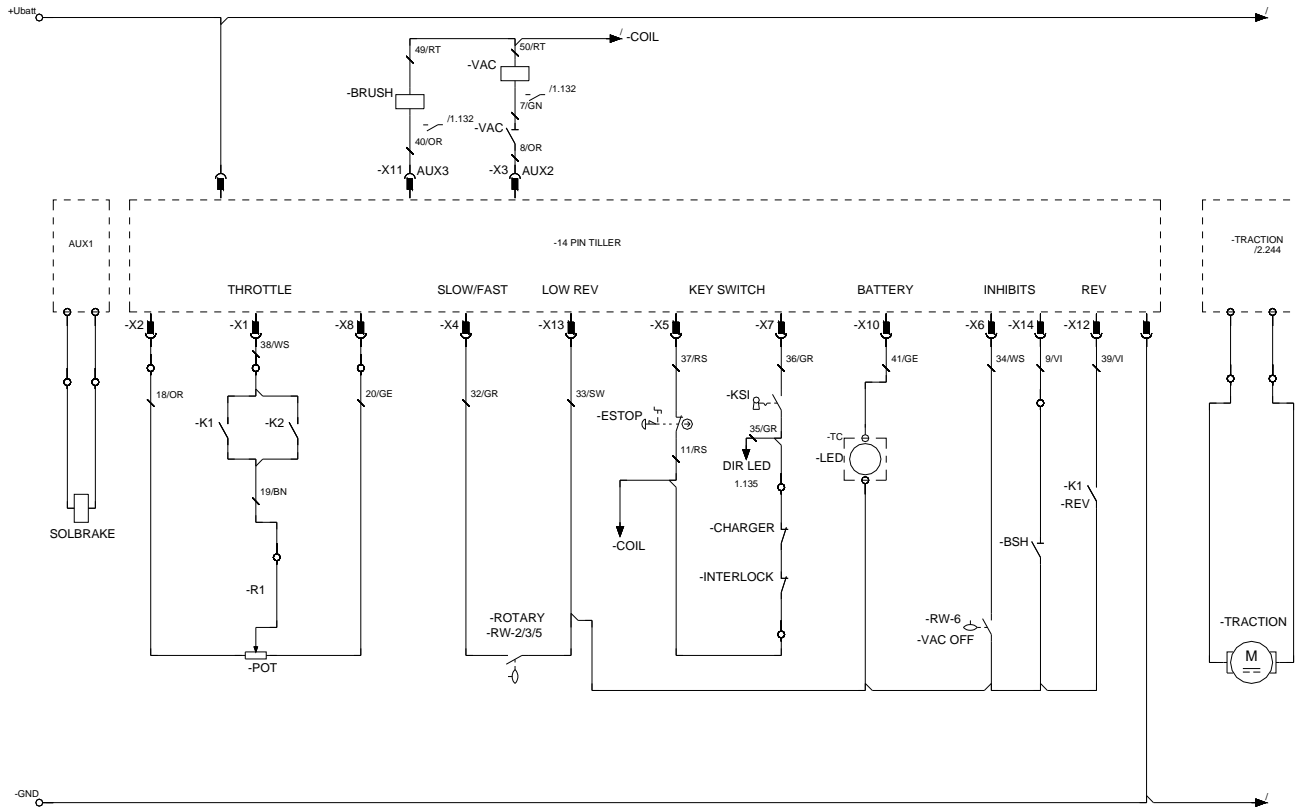

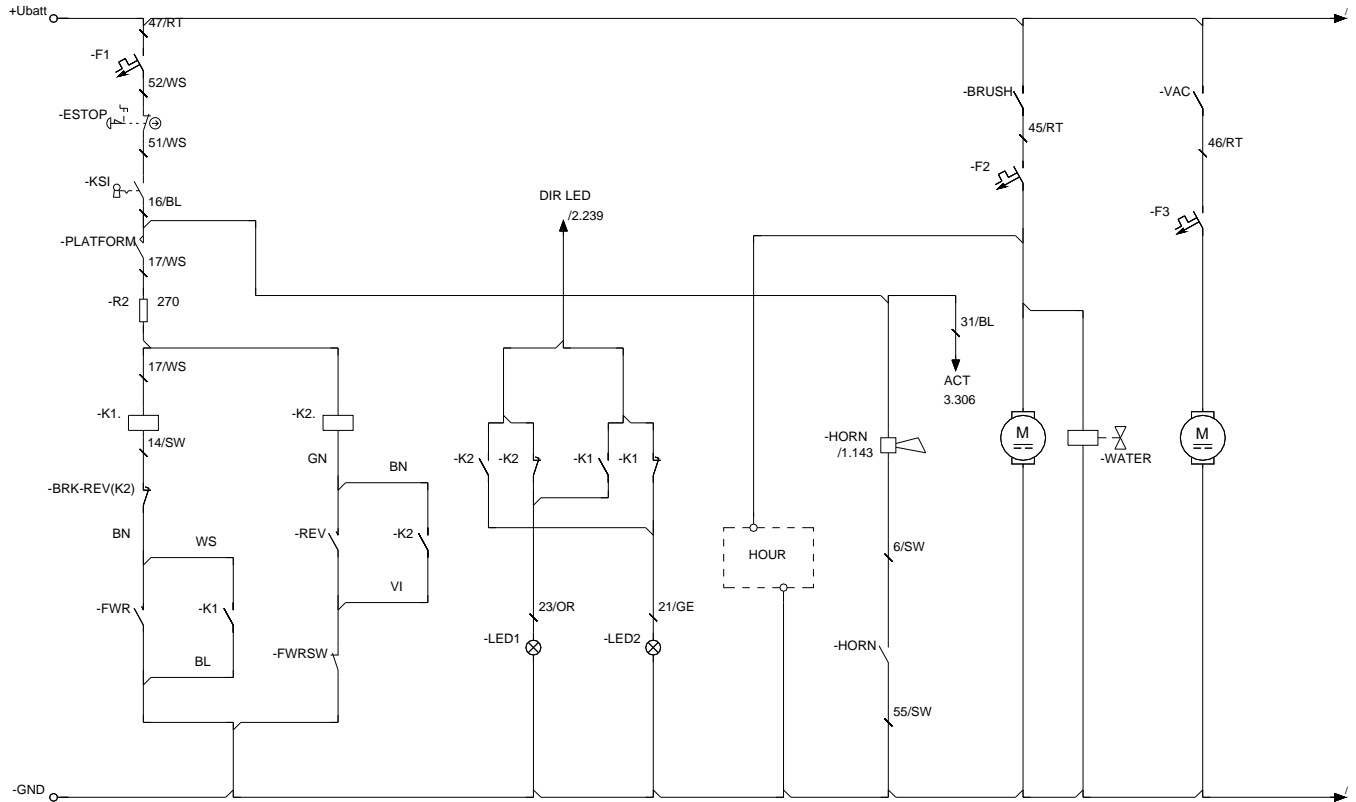

Wiring-Diagram -Prior to Serial No. *(5)

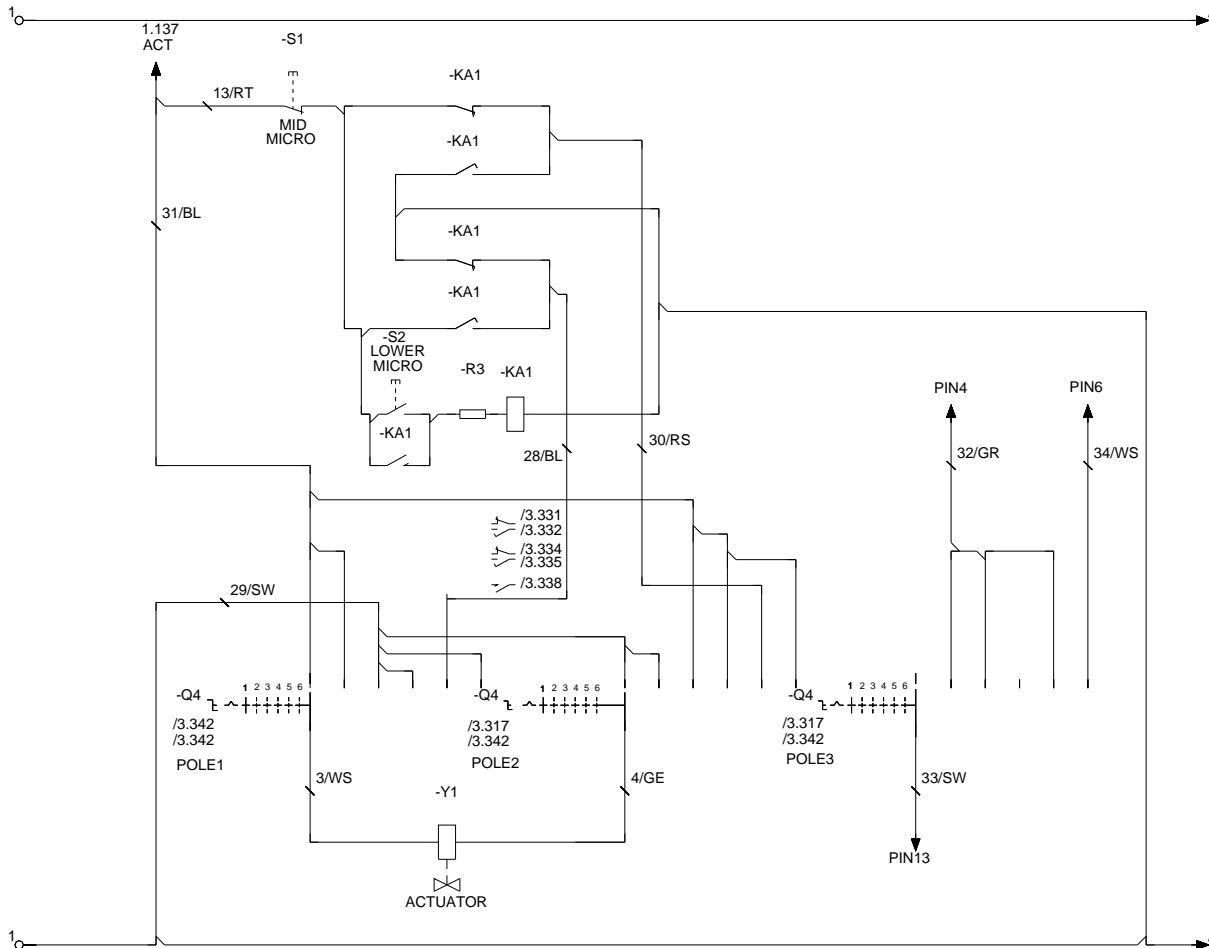

PART NO.	PRV NO.	DESCRIPTION	SERIAL NO. FROM	NOTES
86230140	14622	BREAKER, 1.5A CIRCUIT		
86328180	-	BREAKER, 12A, 250VAC, 32VDC		
86316160	-	BREAKER, 18A, 250VAC, 32VDC		
86002010	14942	BOOT, 3/8 CIRCUIT BREAKER		
86332510	-	BOOT, SEAL PUSH BUTTON 11MM		
86313950	-	SWITCH, SPDT 3 POSN MOM, ARROW		
86007170	72159	SWITCH, KEY 2 POSITION		
86314150	-	KNOB, SELECTOR		
98408880	-	KIT, CS20 ROTARY SWITCH		
86302360	-	DRAIN HOSE		
86199840	090-12A	FLOAT SCREEN CAGE ASSY (SLIP)		
86331980	-	BRUSH SET, 8.633-197.0 SCRUB MTR		
86135310	140686	BRUSH SET, 24/36V VAC, WINDSOR		
86007970	73864	STRAINER, 3/8 IN. NPT 60 MESH		
86312920	-	GASKET, VAC MOTOR		
86326200	-	GASKET, VACUUM INTAKE		
86327850	-	GASKET, REC TANK 68"		
86327840	-	GASKET, VAC MOUNT 27"		
86327830	-	GASKET,.188X.31X41.0		
86317980	-	GASKET, DOME		
86326070	-	BLADE, SQUEEGEE, REAR, DURO 40		
86326060	-	BLADE, SQUEEGEE, FRONT, DURO 40		
86219690	48080	KNOB, 1.5 OD X 5/16-18		

Serial Numbers

REF. NO	MODEL: SERIAL #
1	CS20: 10061250000400, CSC20: 10061330000379
2	CS20: 10061250000432, CSC20: 10061330000436
3	CS20: 10061250000436, CSC20: 10061330000445
4	CS20: 10061250000481, CSC20: 10061330000504
5	CS20: 10061250000617, CSC20: 10061330000632