

Eagle Power



FASTRACTS SC4 4 Gallon Extractor

OPERATION AND PARTS MANUAL

WHEN THE MACHINE IS DELIVERED

Check the carton carefully for signs of rough handling. Remove the machine from the carton. If the machine is damaged, notify the carrier immediately and request an inspection. Be sure to keep the carton, packing inserts, packing lists and carrier's receipt until the inspector has verified your claim.

Eagle Power's liability ceases when the shipment is picked up by the carrier but our customer service staff will be glad to furnish any information needed in connection with the claim and will expedite repair of the machine.

Obtain a return authorization number from the factory before returning the machine to us for repair or service.

BEFORE OPERATING THE MACHINE

Read the manual carefully and completely before attempting to operate the unit. This manual has important information for the use and safe operation of the machine. Keep this manual handy at all times. This machine will ensure years of satisfactory service if operated and maintained according to recommendations in the manual. If additional information is needed, please contact your local distributor or write to:

Eagle Power Products
1174 Northland Drive
Mendota Heights, MN 55120
(651) 686-5399

All information and specifications printed in the manual and parts list are current at the time of printing; however, because of Eagle Power's policy of continual product improvement, we reserve the right to make changes at any time without notice.

This machine is shipped with antifreeze in the solution line system to protect the pump and valves from freezing during transport and storage. Before you use the unit, rinse the solution line system with clean water (See Preparing The Machine).

WARRANTY

To protect your investment, promptly fill in the required information on the warranty card that comes with the unit and mail it back to Eagle Power.

WARNING

To reduce the risk of fire, electric shock, or injury:

- Do not leave the machine when plugged in. Unplug from the outlet when not in use and before servicing.
- Use indoors only.
- Do not allow to be used as a toy. Close attention is necessary when used by or near children.

WARNING

- The machine was designed for use on carpet, hard floors and upholstery extraction application as per instructions and recommendations written in this manual. Any deviation from its proper use or purpose and the consequential damage that may occur is the sole responsibility of the end user.
- Do not use with damaged cord or plug. If machine is not working as it should, or has been dropped, damaged, left outdoors, or dropped into water, return it to an authorized service center.
- Do not pull or carry by cord, use cord as a handle, close a door on cord, or pull cord around sharp edges or corners. Do not run machine over cord. Keep cord away from heated surfaces.
- Do not unplug by pulling on cord. To unplug, grasp the plug, not the cord.
- Do not handle plug or appliance with wet hands.
- Make sure the machine is plugged into an electrical outlet with the same voltage and frequency rating as shown on the nameplate of the machine. Do not attempt to plug a 115 volt machine into a 230 volt outlet.
- Do not immerse or use this machine in standing water. Such use can cause electric shock.
- Do not use to pick up flammable or combustible liquids such as gasoline or use in areas where they may be present.
- Do not expose machine to freezing temperatures.
- To avoid electric shock, do not expose the unit to rain - store it indoors only.
- Connect to a properly grounded outlet only. See "Grounding Instructions."
- Turn off all controls before unplugging.
- Do not use without filters in place.
- Do not put any object into openings. Do not use with any opening blocked; keep free of dust, lint, hair and anything that may reduce air flow.
- Do not pick up anything that is burning or smoking, such as cigarettes, matches or hot ashes.
- Do not use machine for dry vacuuming. This machine is not outfitted with a fine dust filter and it will damage the vacuum motor(s).
- Do not turn on the vacuum-pump switch when the solution tank is empty.
- Use defoamer at all times to prevent damage to the vacuum motor.
- Do not use water in excess of 140 F (62 C).

WARNING

- Use only commercially available carpet cleaners and defoamer intended for use with extraction machines of this type. Do not use dyes, bleaches, ammonia, or other additives. The use of powdered cleaning solution if not diluted properly may result in damage to the pump.
- All servicing of Eagle Power equipment should be performed only by Eagle Power authorized service centers.
- Keep hair, loose clothing, fingers and all parts of body away from openings and moving parts.
- Use extra care when cleaning on stairs.
- Do not use replacement parts other than those specified in the parts list. Proper maintenance of the machine could be affected if substitutions are made.
- Follow maintenance schedule strictly.
- FAILURE TO COMPLY WITH THE WARNING INSTRUCTIONS WILL VOID THE WARRANTY.

GROUNDING INSTRUCTIONS

To protect the operator from electric shock, Eagle Power equipped the machine with an approved three conductor cord and grounding plug. This plug is to be used only with the proper grounding type receptacle.

The machine has a plug like the one shown in figure (A). An adapter is available for connecting three prong type plugs to two prong receptacles (see figure B). The green colored rigid lug extending from the adapter must be connected to a permanent ground such as a properly grounded outlet box. Do not break off or pull out the grounding prong on the plug because it protects the operator from electric shock.

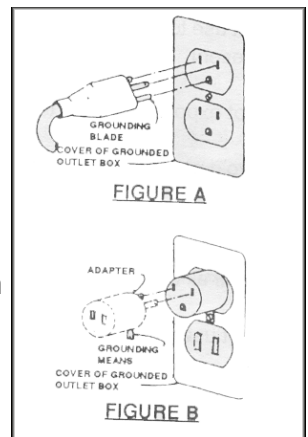

CLEANING TIPS

- Check the condition of the area to be cleaned. Look for loose carpet, heavily soiled area, stains or spots and worn areas. Bring these to the attention of the person in charge before performing the cleaning job. Make sure all edges of the carpet are securely tacked in place and all seams are sewn (or glued) tight. This is your protection against shrinkage.
- Locate an inconspicuous spot on the area to be cleaned. Test carpet for colorfastness before proceeding. Pour the concentrated cleaning solution on the spot, cover with a white towel and place a heavy object on top to absorb the cleaning solution. Wait approximately 10 minutes for any reaction to take place. Remove weight. If there is no color transfer, it should be safe to clean. Apply this procedure if different color-texture carpet is seen in adjacent rooms or areas to be cleaned.
- Remove the furniture from the area to be cleaned. Large pieces can be moved to opposite end of the room from where you start cleaning and replaced when it is completed. After cleaning carpet, place a small square of aluminum foil under the furniture legs to prevent moisture from

- Clean the area with an upright vacuum. **DO NOT USE THIS MACHINE AS A DRY VACUUM!** Heavily soiled carpet or areas of concentrated foot traffic should be treated with recommended prespotting or pre-spray chemicals. If a spotter is used, follow label directions exactly. Do not allow any spotter or pre-spray to dry on the carpet as it may damage the carpet permanently.
- Identify the type of carpet fiber to be cleaned. Most commercial carpet fibers in use are acrylic or nylon based. Best results in cleaning would be obtained if hot water is used to clean these type of fibers. On the other hand, hot water would shrink natural fiber carpeting, like wool and cotton in particular. Exercise caution when cleaning natural fibers by using cool water, testing for colorfastness and applying the least amount of cleaning solution possible.
- Plan your cleaning route. Start cleaning at the farthest point away from where you plugged the machine and work back towards the outlet so that the cord will not get in the way.

TO CLEAN CARPET

1. Prepare the Machine

Make sure “switch” is in the “off” position and all hoses are connected. Using only approved cleaning solution, mix according to the bottle instructions using the “bucket.” To reduce foaming pour 2 ounces of defoamer into the recovery bladder. Place bucket onto machine and close lid.

2. To Clean

Turn switch to carpet position. Turn pump switch “on.” While pushing “activate” switch pull machine as you step backwards. Release the “Activate” switch 6 inches before ending a stroke. Repeat cleaning stroke with 3" overlaps. Continue cleaning until cleaning solution is consumed. Empty and rinse bucket, repeat steps 1 and 2.

3. Check Bucket Lid

If excessive foam appears in lid add 2 ounces of defoamer or empty and rinse bucket, repeat steps 1 and 2.

4. Clean Machine Before Returning

Clean “Lid Filter Screens” and rinse out bucket. Wipe all surfaces including bottom of machine. Remove carpet lint and strings from brush and vacuum nozzle.

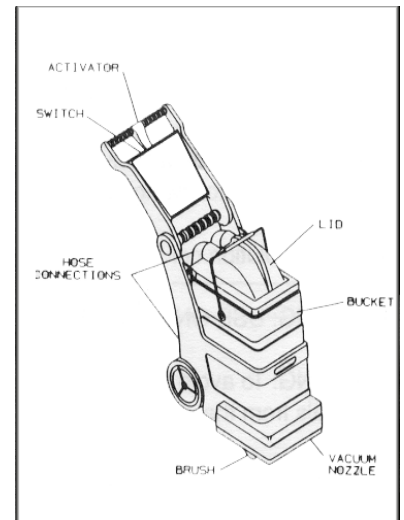

TO CLEAN UPHOLSTERY

Cleaning upholstery with success requires a good knowledge of the type of fabric to be worked on. Look for cleaning instruction label sewn on the underside of the furniture for the recommended method of cleaning the fabric. If it calls for dry cleaning, do not attempt to clean with the wet extraction method. Otherwise, damage to the fabric could occur. Extraction works on most synthetic fabrics.

Before proceeding, test fabric for colorfastness. Pour a small amount of cleaning solution on the fabric in an inconspicuous spot.

Rub the area with a white terry towel. If no color comes off the towel, the fabric should be safe to clean. If color transfers, do not continue.

1. Prepare the Machine

Complete step 1 under Carpet Cleaning Instructions using approved Upholstery Cleaning Solution. Disconnect vacuum hose with black hose cuff from lid and disconnect solution hose from back of machine. Replace them with the upholstery hoses.

2. To Clean

Turn switch to upholstery position. If the machine is an all floor model turn the “solution control valve” located on the side of the machine to “carpet.” Turn pump switch “on.” Depress upholstery tool trigger while pulling tool across upholstery surface with overlapping strokes. To speed drying go over the upholstery without depressing trigger. Continue cleaning until cleaning solution is consumed. Empty and rinse bucket, repeat Step 1 and 2.

3. Check Bucket Lid

See Step 3 under “To Clean Carpet.”

4. Clean Machine Before Returning See step 4 under To Clean Carpet.

DAILY MAINTENANCE

The Fastracts SC4™ is engineered and built to require minimum maintenance. But like any machine, it does require some care to keep it in optimum working condition. Careful attention to these maintenance instructions will give you maximum operating performance and life expectancy of the machine.

CAUTION: Disconnect power cord from the outlet before doing any clean up or maintenance on the machine.

1. Keep the machine clean, inside and out including the lid, bucket, brush and brush chamber.
2. Pour a gallon of clean hot water in the smaller opening of the bucket. Turn the pump on and flush the entire system through the spray nozzles for about a minute to prevent alkaline build-up.
3. Keep filters clean.
4. Quick connect coupler - spray with silicone lubricant to keep coupler from sticking.
5. Valve, upholstery tool - If the plunger on the valve sticks, spray with silicone lubricant.

TROUBLE SHOOTING

PROBLEM	POSSIBLE CAUSE
<i>ELECTRICAL SYSTEM</i>	
No electrical power.	<ol style="list-style-type: none"> 1. Defective power cord. 2. House or building circuit breaker tripped.
Switch is turned on. Power is intermittent to all motor(s)	<ol style="list-style-type: none"> 1. Faulty electrical cable. 2. Defective Switches 3. Loose terminal or terminal connections.
<i>VACUUM SYSTEM</i>	
No Vacuum	<ol style="list-style-type: none"> 1. Vacuum lid is not sealed against tank. 2. Loose vacuum hose, vacuum connection.
Low Vacuum	<ol style="list-style-type: none"> 1. Accumulated dirt on lid screen. 2. Worn out vacuum lid gasket. 3. Lint & dirt build-up on vacuum nozzle. 4. Defective vacuum hose. 5. Loose connection in the vacuum motor(s)
<i>SOLUTION SYSTEM</i>	
Pump motor is on, no spray through spray tip.	<ol style="list-style-type: none"> 1. Small opening side of bucket is empty. 2. Clogged spray tip. 3. Clogged filter screen on end of dome hose. 4. Plugged female quick disconnect coupler. 5. Punctured pump diaphragm. 6. Defective pump check valve. 7. Crack in pump housing. 8. Debris in check valve.
Uneven or weak spray from tip.	<ol style="list-style-type: none"> 1. Clogged or dirty spray tip. 2. Accumulated dirt on filter screen of dome hose. 3. Accumulation of debris inside pump and plumbing. 4. Worn pump bearing (excessive noise) 5. Punctured pump diaphragm. 6. Defective rectifier or motor. 7. Worn nozzles.
<i>BRUSH SYSTEM</i>	
Motor runs, brush won't spin	<ol style="list-style-type: none"> 1. Defective belt. 2. Brush jammed.
Brush motor fails to turn on after circuit breaker has been reset.	<ol style="list-style-type: none"> 1. Brush jammed. 2. Blown breaker. 3. Defective motor. 4. Defective switch. 5. Loose wiring connection.

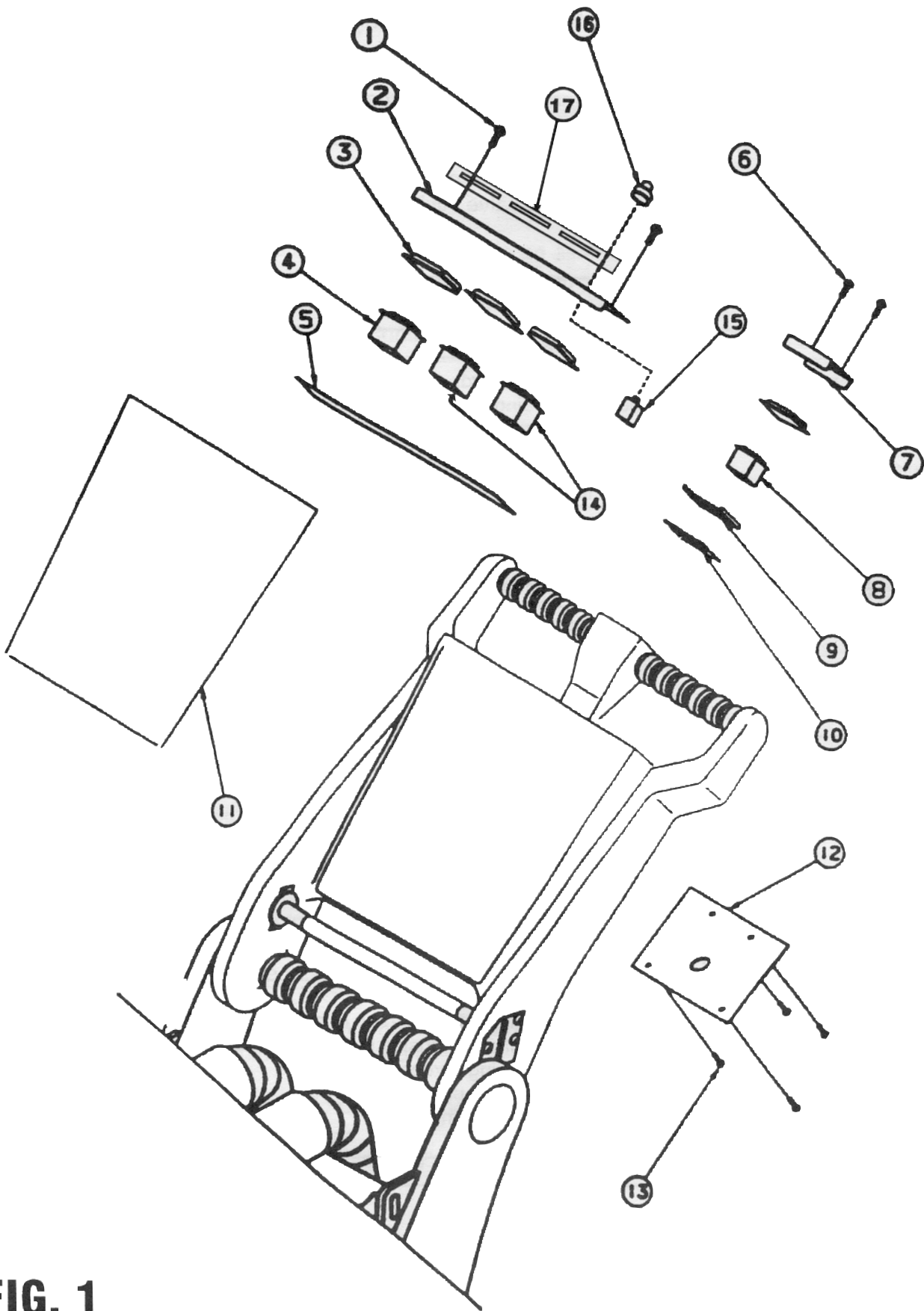

FIG. 1

EAGLE POWER PARTS LIST

ITEM #	PART #	DESCRIPTION	QTY	FIG.
1	C00311	8-32 X 3/8 ROUNDHEAD MACHINE BLACK PHILLIPS SS	2	1
2	D10483	PLATE, MNTNG, SWITCHES, 115V, GREY	1	1
2A	D10713A	ASSY, SWITCHPLATE W/SILKSCREEN LABEL (3 SWITCHES)	1	1
2B	D10998A	ASSY, SWITCHPLATE W/SILKSCREEN LABEL (1 SWITCH)	1	1
3	B00214-2	COVER, SWITCH, ROCKER	2/3	1
4	B00188	SWITCH, ROCKER, DPDT BLACK	1	1
5	E10698	GASKET, SWITCHPLATE, EVA, ADHESIVE BACKED, 3 GALLON UNIT	1	1
6	C10739	SCREW, 6-32 X 5/8, PHIL. PH. BLACK OXIDE	2	1
7	D10481	PLATE, MNTNG, MOMENTARY SWITCH, WHITE EPOXY FINISH	1	1
7A	D10481-1	PLATE, MNTNG, MOMENTARY SWITCH, GREY EPOXY FINISH	1	1
8	B10513	SWITCH, PUSHBUTTON, 250V DP N/O 12 AMP	1	1
9	D10590-1	PLATE, MOMENTARY, MOMEN, EPOXY GREY	1	1
10	E10705	GASKET, MOMENTARY	1	1
11	H10518-5	LABEL, INSTRUCTION	1	1
12	D10496	PLATE, COVER, MNTG, POWER CORD, BLACK	1	1
13	C00311	8-32 X 3/8 ROUNDHEAD MACHINE BLACK PHILLIPS SS	4	1
14	B02211-1	SWITCH, ROCKER, LIT GREEN, 115 / 230V, 20A	1/2	1
15	B10554	CIRCUIT BREAKER, 1.2 AMP, 250 VAC, RESETTABLE	1	1
16	B02193	CIRCUIT BREAKER SEAL	1	1
17	H10509	LABEL, SWITCH PLATE, (2 SWITCHES)	1	1
Not Shown	B10509	HOUR METER	1	1

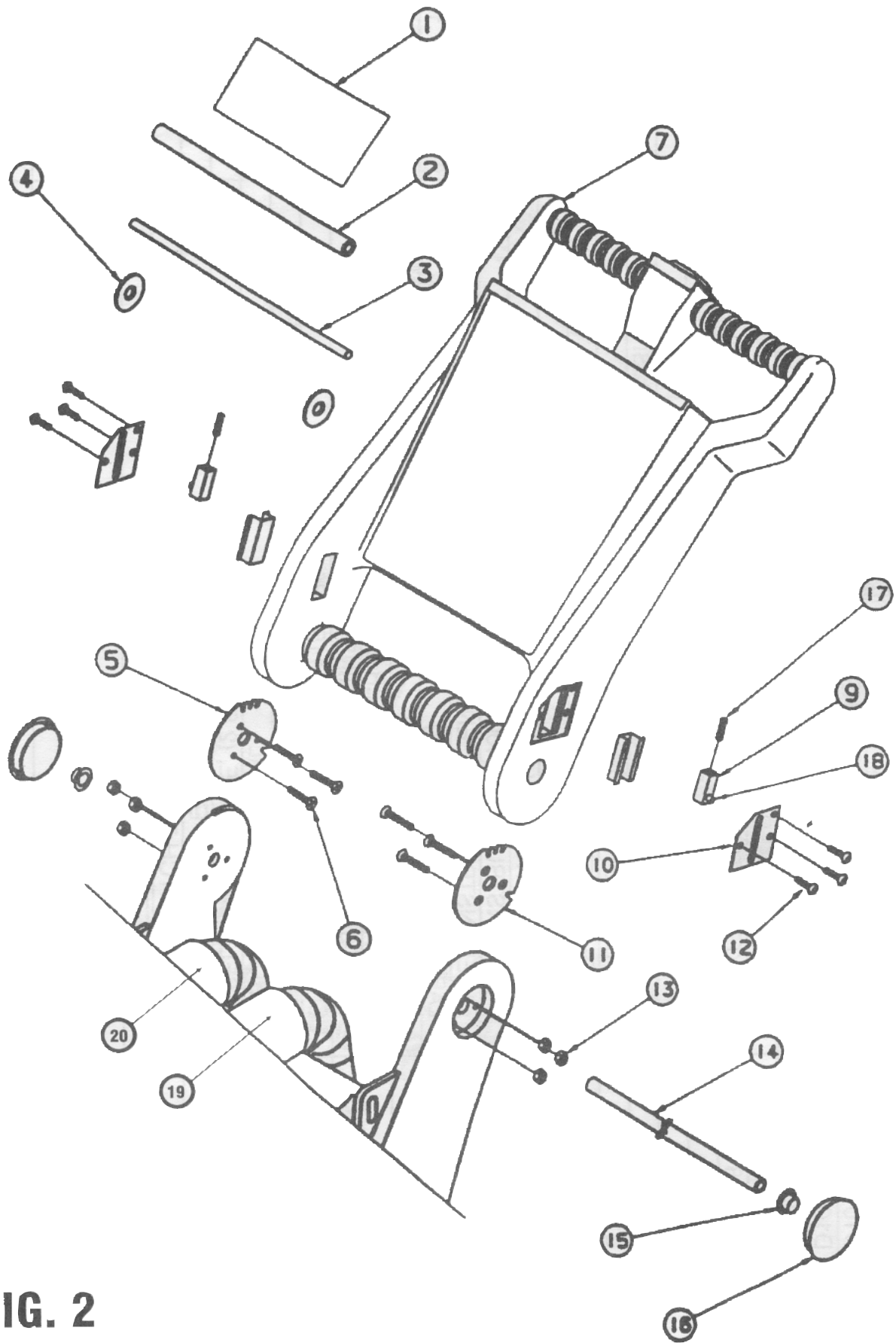

FIG. 2

EAGLE POWER PARTS LIST

ITEM #	PART #	DESCRIPTION	QTY.	FIG.
1	H10777	LABEL, HANDLE ADJUST, BAIL HANDLE	1	2
1A	H10777-1	LABEL, HANDLE ADJUST, MULTILINGUAL	1	2
2	F10691	TUBE, PULL LOCK, 1/4 X 6.75 PVC, BLACK	1	2
3	D10479	ROD, PULL LOCK, PLATED, .025 X 7.750, ZINC PLATED	1	2
4	C10730	WASHER, NYLON, 1.25" OD, .281" ID, .063 THICK	2	2
5	D10485	DISK, LOCKING, HANDLE, RT, COUNTERSUNK AND ZINC PLATED	1	2
6	C90010	SCREW, 8-32 X 1" PHILLIPS, PLATED ZINC	6	2
7	F10540-6	HANDLE, GREY	1	2
8	D10690	BRACKET, GUIDE LOCK,.050 ALUMINUM	2	2
9	F10689	SLIDE LOCK, NYLON	2	2
10	D10487	PLATE, COVER, LOCKING MECHANISM, BLACK ANODIZED	2	2
11	D10486	DISK, LOCKING, HANDLE LFT, COUNTERSUNK AND ZINC PLATED	1	2
12	000311	8-32 X 3/8 ROUNDHEAD MACHINE BLACK PHILLIPS SS	6	2
13	C02320	8-32 NYLON LOCKNUT SS	6	2
14	D10508	TUBE, HANDLE, 10.562 X.50 X.049 WALL, + - 1/16" ON LENGTH	1	2
15	C02305	1/2 CAP NUT PUSH ON	2	2
16	K010142	HOLE PLUG, 2", BLACK	2	2
17	D10494	SPRING, LOCKING MECHANISM	2	2
18	C10692	DOWEL PIN, SLIDE LOCK	2	2
19	J10744	HOSE CUFF, GREY, 1 3/4	1	2
20	J10744-1	HOSE CUFF, BLACK, 1 3/4	1	2

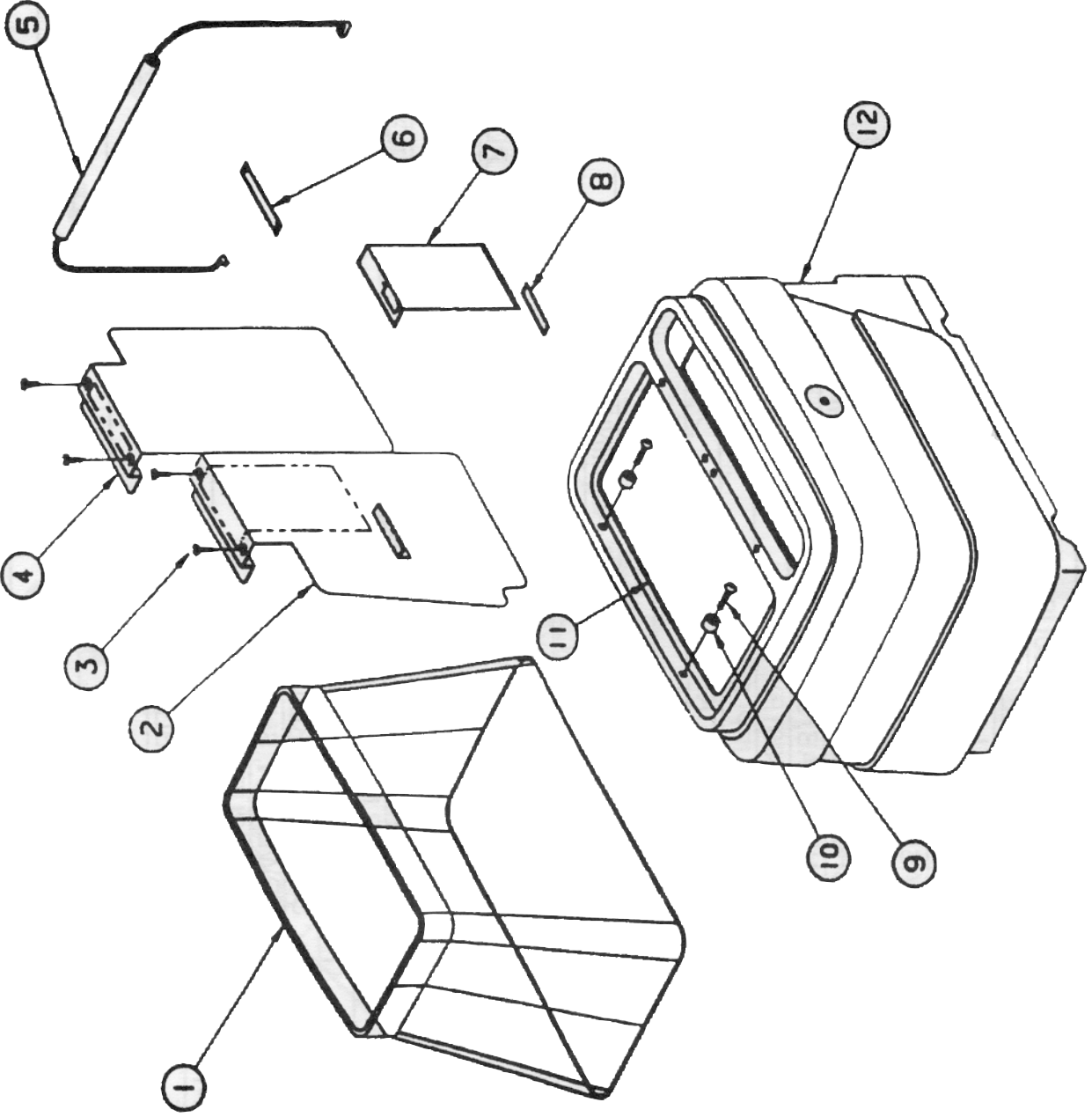

FIG. 3

EAGLE POWER PARTS LIST

ITEM #	PART #	DESCRIPTION	QTY.	FIG.
1	10490A	ASSY, BLADDER, 3 GALLON UNIT, ALL VERSIONS	1	3
2	D10760	PLATE, DIVIDER, BUCKET, FRONT, EPOXY GREY	1	3
3	C00307-12	8/32 X 1/2 FLATHEAD MACHINE PHILLIPS, STAINLESS STEEL	4	3
4	D10762	PLATE, DIVIDER, BUCKET, REAR, GREY EPOXY	1	3
5	D10452	ASSY, BAIL HANDLE1	1	3
6	H10572	LABEL, ANTI-FOAM SOLUTION	1	3
7	H10740	LABEL, CLEANING SOLUTION, DO NOT OVERFILL	1	3
8	H10571	LABEL, FILL LEVEL, TANK		3
9	C10737	SCREW 8-32 X 5/8, SS TRUSS HEAD, PHILLIPS	2	3
10	K00664	SPACER, NYLON, NATURAL 3/8 X.1 94 X 5/15	2	3
11	E10771	GASKET, BUCKET, .375 X 33 20 LB. PORON .125", W/5 MIL #300 3M, ACRYLIC ADHESIVE #9672	1	3
12	F10539	BUCKET, FAB, LINEAR, GREY	1	3

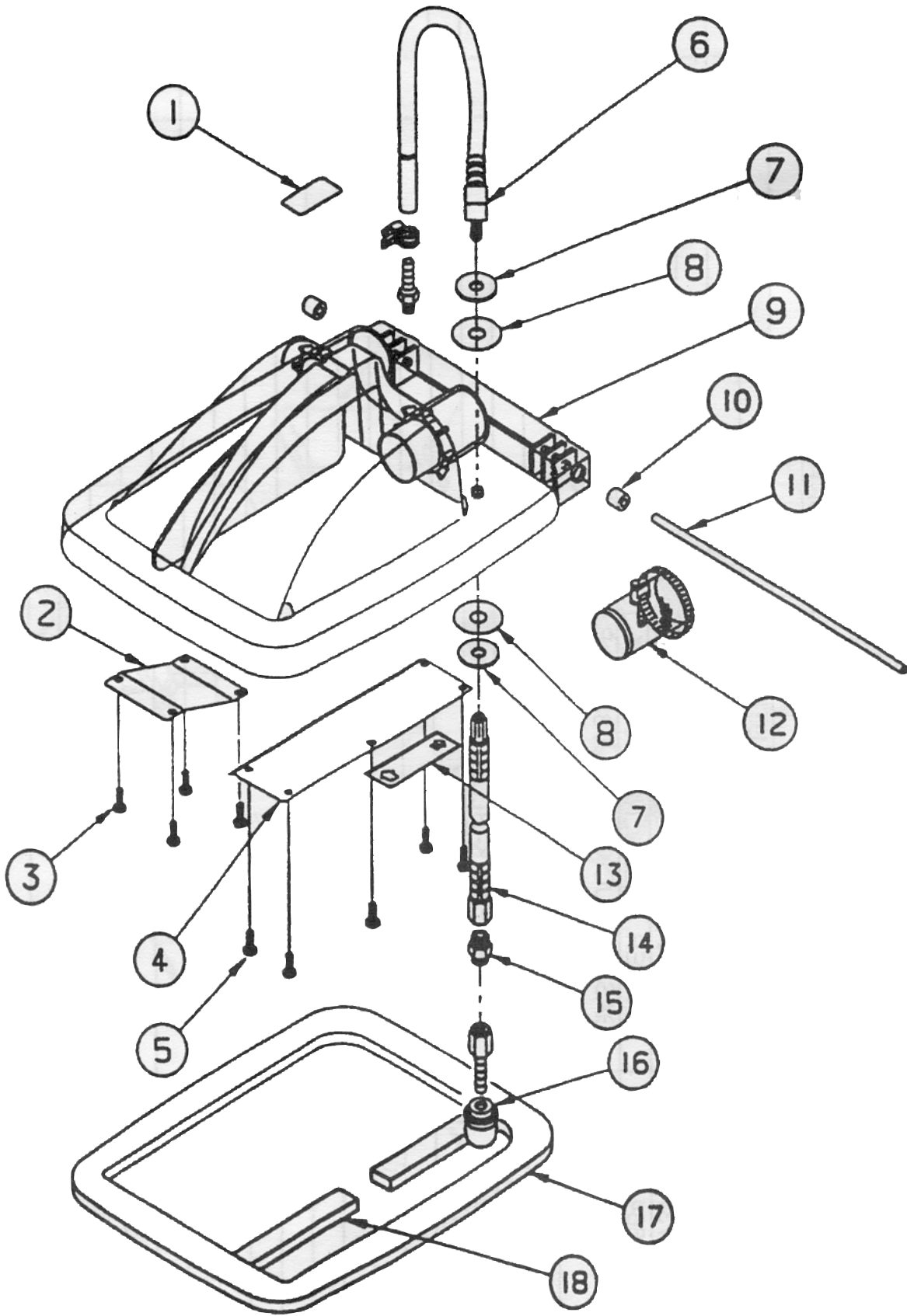

FIG. 4

EAGLE POWER PARTS LIST

ITEM #	PART #	DESCRIPTION	QTY.	FIG.
1	H10574	LABEL, PATENTS	1	4
2	D10768	PLATE, DEFLECTOR, DOME, .080 ALUMINUM	1	4
3	C00324-38	6/32 X 3/8 ROUNDHEAD MACHINE PHILLIPS, STAINLESS STEEL	7	4
4	D10761	PLATE, LID GASKET, 7.859 X 2.03 X.080 5052-H32 ALUMINUM	1	4
5	C02238-38	6/32 X 3/8, SCREW, S/S, FLATHEAD, MACHINE SCREW	2	4
6	10780A	ASSY, HOSE, PUMP TO DOME	1	4
7	C10503	WASHER, FLAT, 1" X.048" X.437 ID, STNLS	2	4
8	E10504	GASLET, RUBBER, 1" X.032 X.437 ID, 35 SHORE, PURE GUM	2	4
9	F10454	DOME, INJECTION MOLDED	1	4
10	E10732	TUBE, LATEX, 1/4" ID, 1/8" WALL, 1/2' LENGTH, DOME	2	4
11	D10524	SHAFT, DOME HINGE, .250 X 10.50, 6061 T6 ALUMINUM	1	4
12	D10767	FILTER, AIR FLOW, 1-1/2 X 2-1/2", STAINLESS STEEL #30MESH, 70% OPEN 9.5 WIRE DIA.	1	4
13	H10565	LABEL, KEEP FILTER SCREEN CLEAN, DOME	1	4
14	10543A	ASSY, HOSE W/FILTER, CHK VALVE,	1	4
15	G10731	CHECK VAVLE	1	4
16	D10478	FILTER SCREEN, BUCKET 50 X 50 MESH .008 304 STAINLESS WIRE, 36% OPEN	1	4
17	E10533	GASKET, DOME, PORON 4701-12-20250-1604, W/IF 2013 P.S.A. ONE SIDE	1	4

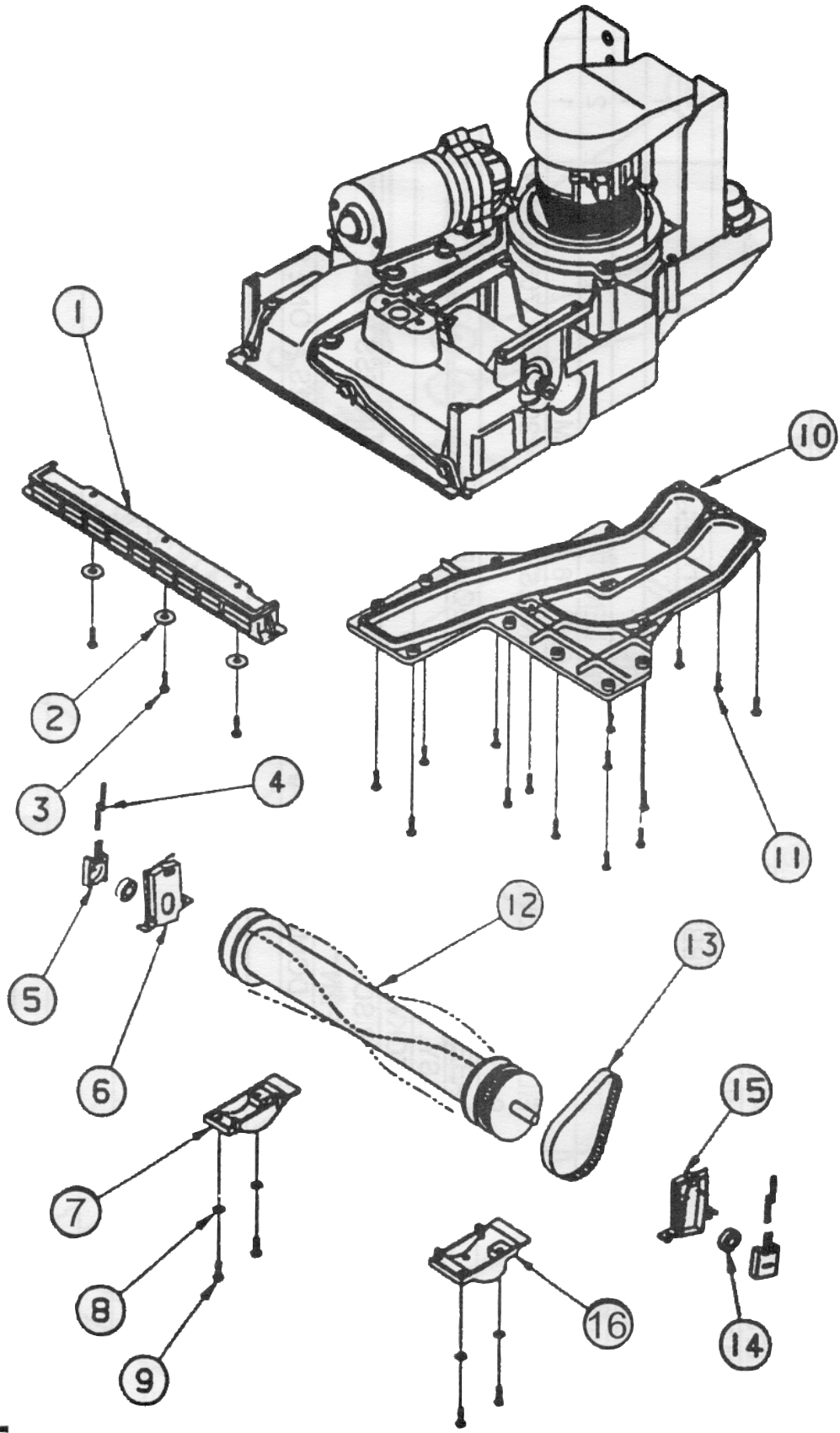

FIG. 5

EAGLE POWER PARTS LIST

ITEM #	PART #	DESCRIPTION	QTY.	FIG.
1	F10474	SHOE, VACUUM, INJECTION MOLDED	1	5
2	C03251	#8 SAE WASHER SS	3	5
3	C00310-34	8/32 X 3/4 ROUNDHEAD MACHINE PHILLIPS	3	5
4	D10426	SPRING, BRUSH, 1.25 x 1.80 X .022, 5.2 LBS./IN ZINC PLATED MATERIAL CERT REQUIRED ON EA SHIPMENT	4	5
5	F10410-1	SLIDE BLOCK, BRUSH BEARING, 3 GALLON UNIT	2	5
6	F10413	BRUSH RETAINER, LEFT, NON-BELT SIDE	1	5
7	F10423-1	BRUSH RETAINER COVER, LEFT, NON-BELT SIDE	1	5
8	C10736	WASHER, CUSHIONING, #8 X.312 OD X.150 ID, BRUSH ASSY	4	5
9	C10737	SCREW, 8-32 X 5/8, SS TRUSS HEAD, PHILLIPS	4	5
10	F10430	COVER, BOTTOM, INJECTION MOLDED	1	5
11	C11020	SCREW, 8-16 X 1", PLASTITE PHILLIPS PAN HEAD	15	5
12	10420-3A	ASSY, BRUSH, 4 ROW, .12 BRISTLE, WITH PULLEY	1	5
13	L10448	BELT, 3 GALLON, 7MMX300MM WITH 3MM PITCH, NEOPRENE, FIBERGLASS TENSION MEMBERS	1	5
14	10425	BEARING, BRUSH, 3 GALLON	2	5
15	F10422	BRUSH RETAINER, RIGHT, BELT SIDE	1	5
16	F10416-1	BRUSH RETAINER COVER, RIGHT, BELT SIDE	1	5
17	E03429-1	BOTTOM COVER GASKET	4	5
18	C03251	WASHER		

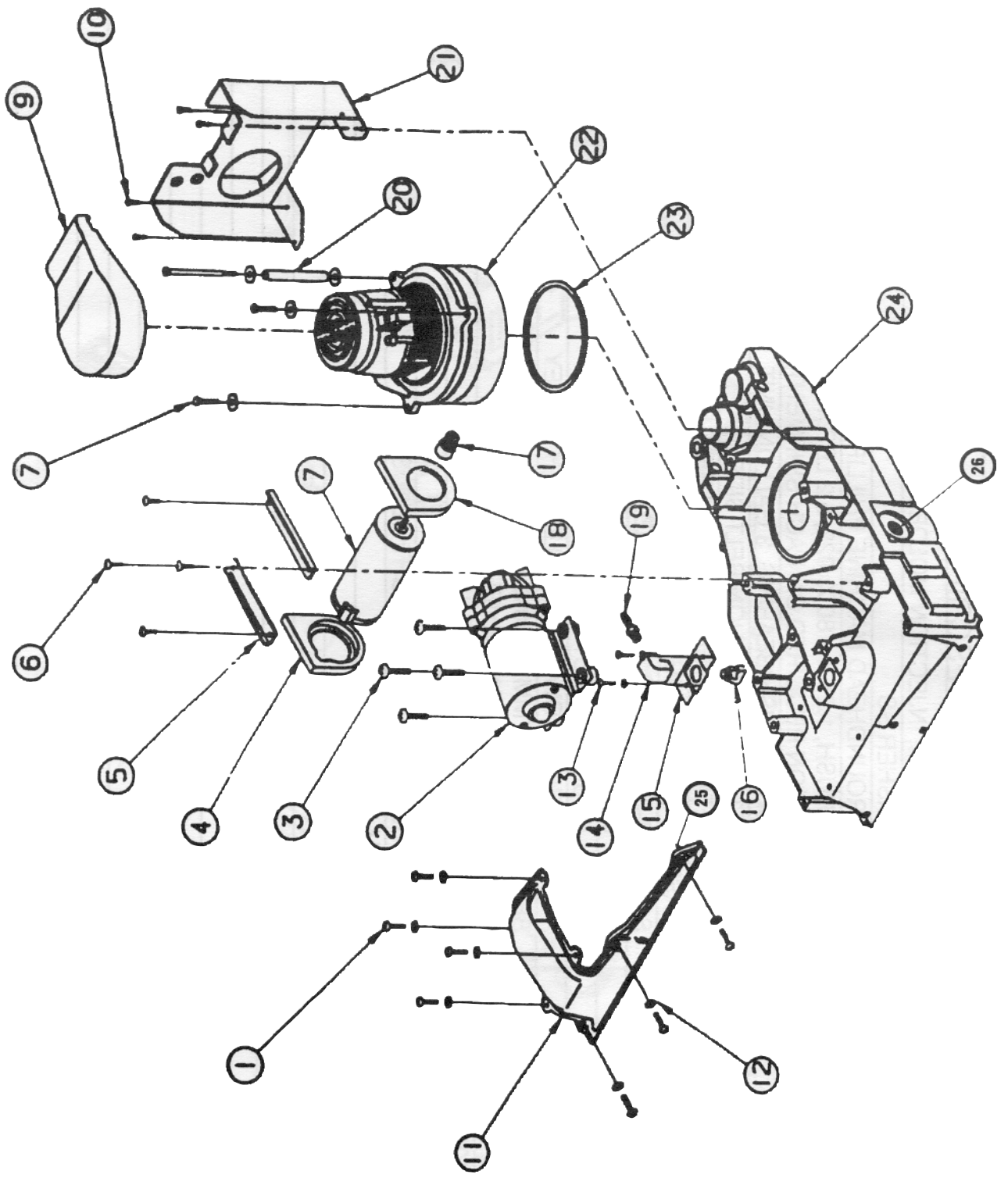

FIG. 6

EAGLE POWER PARTS LIST

ITEM #	PART #	DESCRIPTION	QTY.	FIG.
1	C10737	SCREW, 8-32 X 5/8, SS TRUSS HEAD, PHILLIPS	7	6
2	10763A	PUMP, 115V, SHURFLO, 1.4 GPM, W/BYPASS ASSY	1	6
3	C02308	1/4-20 x 1 ROUND HEAD PHILLIPS MACHINE SS	4	6
4	E10446	MOTOR MOUNT, REAR, FLOJET MOTOR, SANTOPRENE, 3 GALLON UNIT	1	6
5	D10447	CLAMP, BRUSH MOTOR	2	6
6	C10737	SCREW, 8-32 X 5/8, SS TRUSS HEAD, PHILLIPS	4	6
7	G10442	MOTOR, BRUSH, 115 VAC, 60H FLOJET	1	6
8	10672A	ASSY, BOLT 1-1/4"	2	6
9	F10542	INTERCOOLER, BLACK	1	6
10	C10500	SCREW, 8-16 X 1', PLASTITE, PHILLIPS PAN HEAD	4	6
11	F10429	COVER, SUCTION, INJECTION MOLDED	1	6
12	C03251	BACKUP WASHER, 3/16 ID,.490 OD, ALUMINUM, .060 THICK	7	6
13	C00310-12	SCREW, 8-32 X 1/2, PHILLIPS PAN HEAD	2	6
14	A00073	90° ELBOW, 1 /8 FP X 1 /8 FP, BRASS	1	6
15	D10506	BRACKET, SPRAY NOZZLE, BLACK ANODIZED	1	6
16	A00089-6	SPRAY TIP, 1/8" X 11006	1	6
17	D10437	PULLEY, 16 TOOTH DIECAST ZAMAK 3	1	6
18	E10445	MOTOR MOUNT, FRONT, FLOJET MOTOR, 3 GALLON UNIT	1	6
19	A00076	BARB 1/4" TO 1 /8' MP, BRASS	1	6
20	10673A	ASSY, BOLT, 1/4 X 4"	1	6
21	D10475	BACKPLATE, BLACK	1	6
22	00520-1A	VACUUM 106", 115V 5.7, REVERSE FAN	1	6
23	E10521	GASKET, VAC MOTOR, 20 LB., PORON	1	6
24	10427-2A	CHASSIS, INJECTION MOLDED ASSY.	1	6
25	E03429	LENS GASKET	4	6
26	G10758	BALL VALVE	1	6

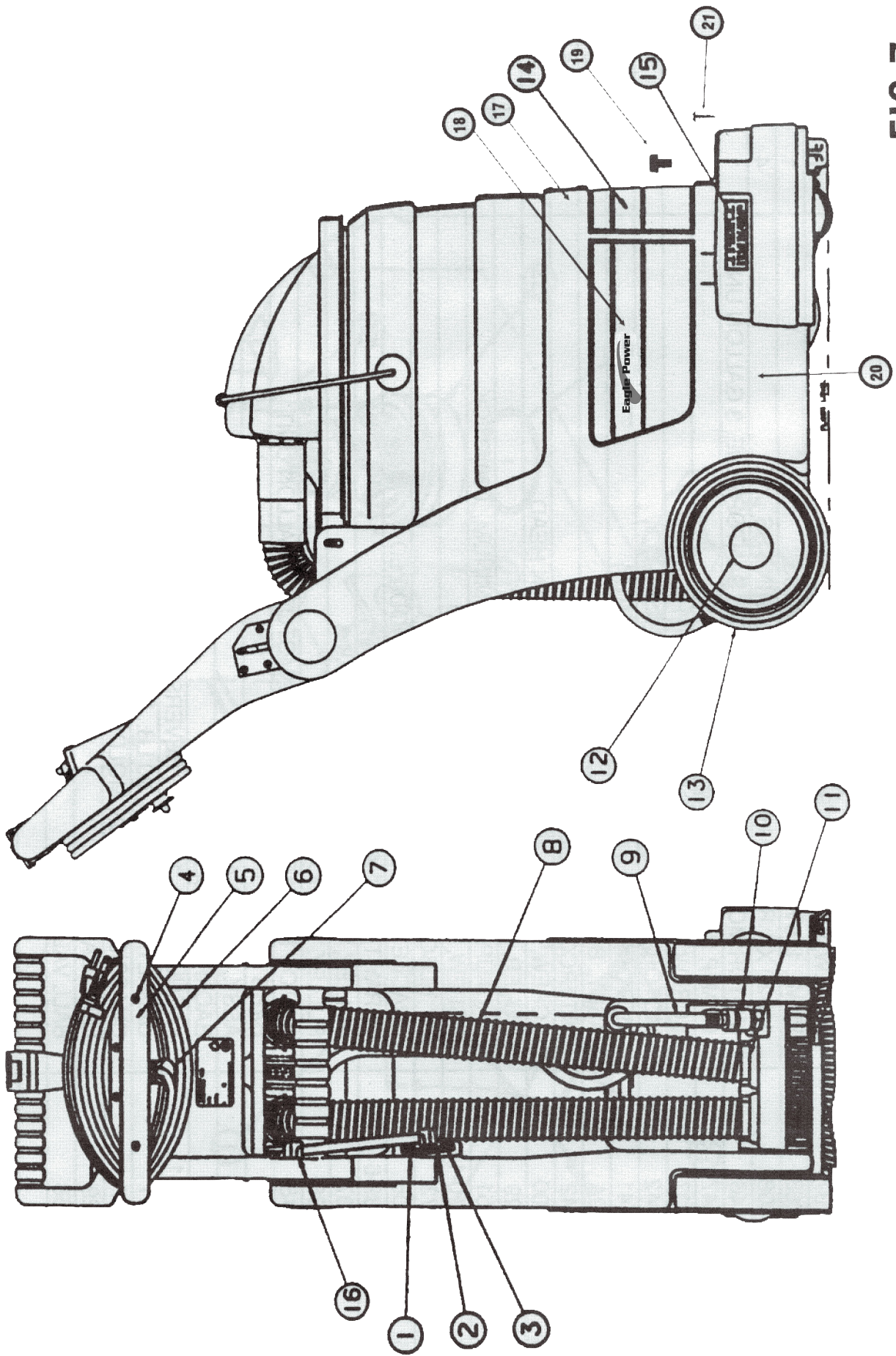

FIG. 7

EAGLE POWER PARTS LIST

ITEM #	PART #	DESCRIPTION	QTY.	FIG.
1	C90006	SCREW, 6-32 X 3/4, PHILLIPS PAN HEAD, BLACK OXIDE	4	7
2	D10618	PLATE, STRAIN RELIEF, BLACK	2	7
3	E10723	GASKET, STRAIN RELIEF	2	7
4	C00311	8-32 X 3/8 ROUNDEHEAD MACHINE, BLACK PHILLIPS SS	2	7
5	D10501	PLATE, CORD WRAP, BLACK	1	7
6	B10719	POWER CORD, 3/16 AWG, 300VAC, SJTO, 20', BLACK, W/NEMA 5-15 PLUG AND CORD CLIP	1	7
7	B02215	STRAIN RELIEF, BLACK TRUMPETED, 14-18 GA	1	7
8	J00618-1	1 1/2 WIRE SUPPORTED GRAY, WIRE REINFORCED	6	7
9	10531A	ASSY, HOSE, QUICK CNNCT	1	7
10	A00109	QUICK DISCONNECT 1/8 SOCKET X 1/8 FP BL	1	7
11	J00656	CLAMP, HOSE, 1 1/2" NYLON, REUSABLE, BLACK	2	7
12	G10458-2	CAP, WHEEL HUB, BLACK	2	7
13	G10458	WHEEL, 7 INCH, NO BEARING /375" BORE, GREY	2	7
14		LABEL, CENTER, WRAPAROUND	1	7
14A		LABEL, CENTER, WRAPAROUND,	1	7
15	H10577	LABEL, CAUTION, RISK OF ELECTRIC SHOCK, 1'X 2.875	1	7
16	B10734	STRAIN RELIEF, CORD, MAIN HARNESS	2	7
17		LABEL, MOTOR HOUSING, RIGHT	1	7
17A		LABEL, MOTOR HOUSING	1	7
18		LABEL, MOTOR HOUSING, LEFT	1	7
18A		LABEL, MOTOR HOUSING, LEFT	1	7
19	K10510	PLUG, HOLE 1 "	2	7
20	F10541-6	MOTOR HOUSING	1	7
21	C90007	SCREW, 10-32 X 5/8" PHILLIPS	2	7

3 GALLON MODEL

115 V AC, 60 HZ
WIRING DIAGRAM, NO.10550

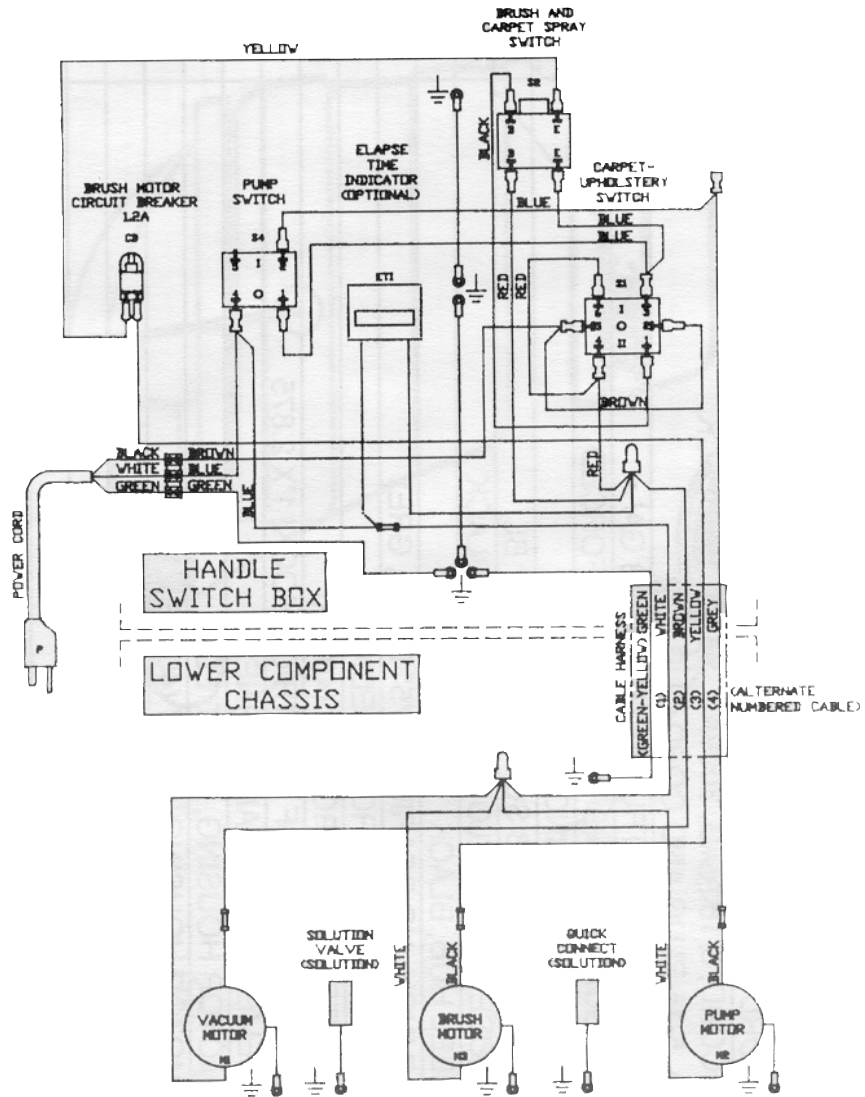

HOUR METER (OPTIONAL)
FLOJET BRUSH MOTOR
PUMP SWITCH
2 STAGE VAC. HIGH PERFORMANCE
16 AWG POWER CORD
5 WIRE, 16 AWG CABLE HARNESS
SOLUTION CONTROL VALVE (OPTIONAL)

REVISIONS		
REV	CHANGE ORDER NUMBER	DATE
#1		5/17/95
#2		9/26/96
#3		2/27/97
#4		3/27/97

UNLESS OTHERWISE SPECIFIED DIMENSIONS ARE IN INCHES TOLERANCES UNLESS OTHERWISE SPECIFIED	APPROVALS	DATE	SCALE
DESIGNER: S. SPINAKOVICH	DATE: 6/17/95	SCALE: B	
CHECKER: EDIC	DATE: 6/17/95	SCALE: B	
PART NO. 10550	REV. #4	SHEET 1 OF 1	
ENGINEERING DIVISION 1729 BAKER AVENUE LOS ANGELES, CA 90029	DIAGRAM, 115 VAC, 60 HZ 3 GAL. EDIC		

NOTES

Eagle Power

Warranty Policy

Limited Warranty

Eagle Power Products (EPP) warrants new cleaning equipment against defects in material and workmanship under normal use and service to the original purchaser as detailed below.

10 Years

Subject to the conditions stated below, EPP warrants polyethylene tanks and housings to be free from defects in materials and workmanship for a period of ten years.

3 Years

Subject to the conditions stated below, EPP warrants all automatic scrubber components to be free from defects in materials and workmanship for a 3-year period. Parts replaced or repaired are warranted for the remainder of the original warranty period.

1 Year

Subject to the conditions stated below, EPP warrants all other cleaning equipment components to be free from defects in materials and workmanship for a 1-year period. Parts replaced or repaired are warranted for the remainder of the original warranty period. Batteries are prorated for one year.

EPP will furnish and charge for replacement parts, including transportation, to the original owner through an EPP authorized service center. If the part is returned within 30 days and is found defective, the owner will be credited for the cost of the replacement part including shipping and handling.

Labor charges are covered for one year from the date of purchase if provided by an authorized EPP service center. Travel is covered for 90 days for battery operated equipment only.

Wear items exempt from warranty include belts, carbon brushes, power cords, wheels, pad drivers, clutch plates, brushes, pads, handle grips, filters, screens, throttle cables, and squeegees.

This warranty shall not apply to failures caused by misuse or abuse, improper maintenance as stated in the operation manuals, use of unauthorized repair parts, repairs by other than an EPP authorized service center, and damage in transit.

EPP disclaims and denies any liability for any direct, indirect, special incidental or consequential damage which may be suffered as a result of sale, delivery, servicing, use, loss of any product, downtime, labor, freight, or other charges not expressly included herein.

Date Purchased: _____

Model Number: _____

Serial Number: _____

Please be sure to record this information. This information will be necessary for future warranty claims.



1174 Northland Drive Mendota Heights, MN 55120
651.686.5399 Fax 651.686.5695
www.eaglepower.com

Eagle Power Products Sales and Service Provided by: