

# Service Manual



## For the **SCV2832E, SCV2426, SCV280000 & ES2832 Automatic Scrubbers**

For:  
Training  
Troubleshooting  
Adjustments



# Contents



1	Cautions -----	Page 4
2	Maintenance Intervals -----	Page 5
	2.1 Customer Maintenance -----	Page 6
	2.2 Maintenance I after every 125 hours of operation-----	Page 7
	2.3 Maintenance II after every 250 hours of operation-----	Page 8
	2.4 Maintenance S after every 500 hours of operation, minimum once per year-----	Page 9
3	Service Mode -----	Page 10
	3.1 Service Mode SC280000 -----	Page 11
4	Brush Pressure Settings-----	Page 13
	4.1 ES2832 and CP2832 -----	Page 14
5	Error Codes -----	Page 16
6	5.1 Table of Error Codes (LCD)-----	Page 17

# Contents



5.4 Error Codes (LED) -----	Page 21
6 Side Squeegee Adjustment (cylindrical) -----	Page 25
6.1 Side Squeegee Adjustment (disk)-----	Page 26
7 Rear Squeegee Adjustment -----	Page 27
8 Replacing the Brush Actuator On SC2832 Models-----	Page 30
9 Trouble Shooting the Code 8 Error -----	Page 33
10 Testing the Throttle Potentiometer-----	Page 36
11 Identifying the Cause of Trio Controllers -----	Page 38
12 Notes-----	Page 39

# 1. Cautions

- **Always disconnect the A.C. Cord from the outlet and and D.C. Cord from the battery pack before servicing the machine. Except for making voltage and current measurements.**
- **Before replacing or disconnecting any electrical componets, disconnect the battery pack from the machine first. Failure to do so could cause a short circuit.**
- **After any repair work test the machine for proper operation.**
- **When servicing the machine always observe the general safety and accident prevention guidlines.**
- **Do not attempt to power up the controllers with battery chargers. Permanent damage will occur to the controller. 36 volt chargers usually have an output in excess of 48 volts.**
- **Use only Minuteman approved battery chargers.**
- **Do not apply power directly to the motors without first disconnecting them from the controller circuit.**

## 2. Maintenance Intervals

### •**Maintenance Intervals:**

In a modular structure, the Minuteman System Maintenance determines the specific technical procedures to be performed and sets the time interval between the two maintenance cycles.

For each of the maintenance cycle, the replaceable parts are determined as well. Further details described in the specific chapters.

### •**Minuteman System Maintenance K:**

To be performed by the customer (in daily or weekly intervals) according to the maintenance and care instructions as specified in the operating instructions.

The operator must be professionally instructed after delivery of the machine by selling dealer.

### •**Minuteman System Maintenance I:** (after every 125 hours of operation)

To be performed an authorized Minuteman Service Center in accordance with the machine-specific system maintenance.

### •**Minuteman System Maintenance II:** (after every 250 hours of operation)

To be performed an authorized Minuteman Service Center in accordance with the machine-specific system maintenance.

•**Minuteman System Maintenance S:** (after every 500 hours of operation, safety check) To be performed by an authorized Minuteman Service Center in accordance with the machine-specific system maintenance.

## 2.1 Minuteman System Maintenance K



To Be Performed By Customer	Interval	
	Daily	Weekly
Perform the Minuteman System Maintenance K	o	
Fill the clean water tank and mix the proper amount and type of cleaning solution.	o	
Charge the batteries.	o	
Check the brush head. Clean, if needed with a damp cloth. Do not get water inside of the motors.	o	
Check the squeegee, clean if needed.	o	
Check the lid gasket on the recovery tank	o	
Empty and flush the recovery tank with clean water.	o	
Clean the filter inside of the recovery tank. If missing replace.	o	
Check the water levels all the batteries. Add distilled water, if needed. Do not over fill.	o	
Check the brushes and pads for wear. Replace if needed.		o
Check the squeegee hose for clogs, damage and wear. Replace if needed.		o
Check the squeegee rubbers for wear and cuts. Flip the rubber blades over or replace.		o
Check the solution filter. Clean if needed.		o
Flush the clean water tank and system with warm water.		o
Test all the functions of the machine.		o

## 2.2 Minuteman System Maintenance I



To Be Performed By An Authorized Service Center	Interval
	Every 125 hours of operation
Perform the Minuteman System Maintenance I	0
Check the battery charger. Make sure it is functioning correctly.	0
Check the recovery lid gasket. Replace if needed.	0
Lubricate the brush lift linkages with grease. Use a small brush.	0
Check for loose hardware, tighten if needed.	0
Check the tire pressure on pneumatic wheels at 65 psi, if equipped.	0
Lubricate the squeegee linkages with grease. Use a small brush.	0
Inspect the entire machine for damage, wear and proper operation.	0

## 2.3 Minuteman System Maintenance II



To Be Performed By An Authorized Service Center	Interval
	Every 250 hours of operation
Perform the Minuteman System Maintenance II	0
Inspect the caster wheels for wear and damage. Repair, if needed.	0
Inspect the carbon brushes for wear in the transaxle. Replace, if needed.	0
Inspect the recovery drain hose for wear or damage. Replace, if needed.	0
Inspect the brush bumper rollers for wear or damage. Replace, if needed.	0
Inspect the carbon brushes in the brush motors for wear. Blow out with compressed air.	0
Inspect the recovery hose for damage or wear. Replace, if needed.	0
Inspect the squeegee assembly for proper adjustment. Repair, if needed.	0
Test the machine for proper operation.	0



## 2.4 Minuteman System Maintenance S



To Be Performed By An Authorized Service Center	Interval
	Every 500 hours of operation
Perform the Minuteman System Maintenance check	0
Replace the carbon brushes in the transaxle.	0
Replace the carbon brushes in the brush motors.	0
Test the machine for proper operation.	0

# 3. Service Mode

The Service mode switch can be used to lower the brush deck. Press and hold the switch in the down position and the deck will lower. Once it is in service mode, the deck can be raised and lowered by pressing the top or lower part of the rocker switch. To return the machine back to normal operation: Turn the key switch off and back on. The machine will reset.

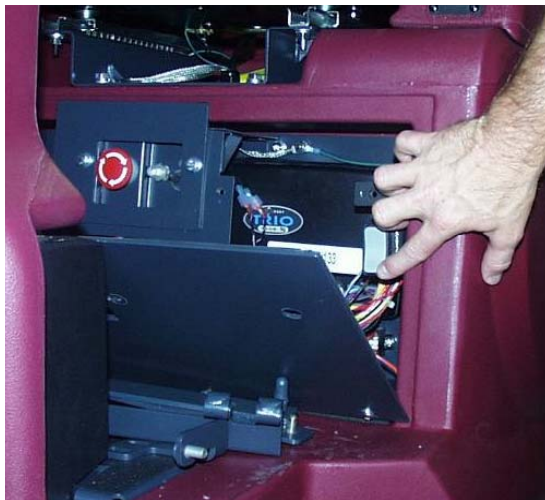

The switch located below the seat behind the panel on the SCVs. (Not equipped on the SC280000 models)

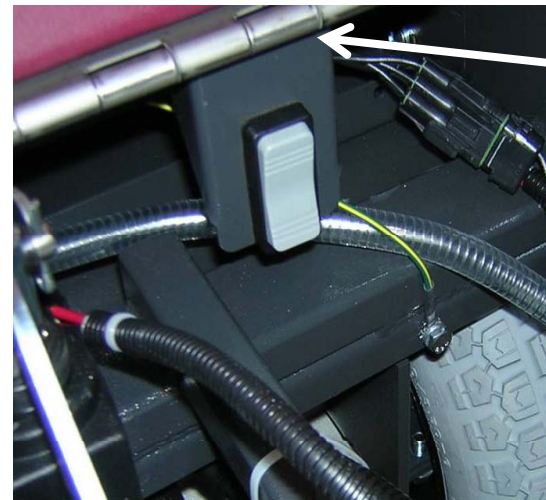

The switch is located below the recovery tank on the ES2832 and CP2832 models.

## 3.1 Service Mode SC280000

Push and hold the brush pressure down button for 15-20 seconds.

Once it is in service mode, You can raise and lower the deck by pressing the brush pressure up and down arrows.

To return the machine back to normal operation: Turn the key switch off and back on. The machine will reset.



## 3.2 Service Mode SCV2426

The Service Mode Switch on the SCV2426 is located next to the step on the front of the machine on the operator's left side.

Once it is in service mode, the deck can be raised and lowered by pressing the upper or lower part of the rocker switch.

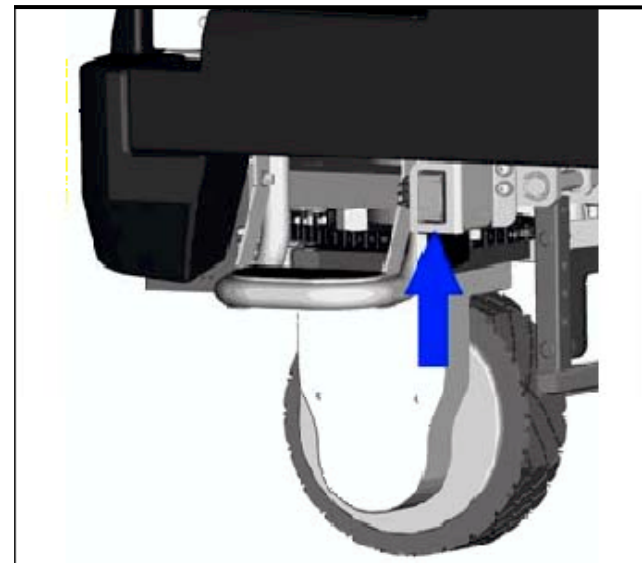

To return the machine back to normal operation: Turn the key switch off and back on. The machine will reset.

# 4. Brush Pressure Settings

The brush pressure range can be changed when changing the type of deck on the SC2832E, SC2426P, CP2832 and ES2832 models.

Connect the orange/violet wire into the terminal block with red/black wire group for cylindrical decks and unplug it for the disk decks.

The terminal block is located below the Trio controller on the SCVs and below the control panel on the ES

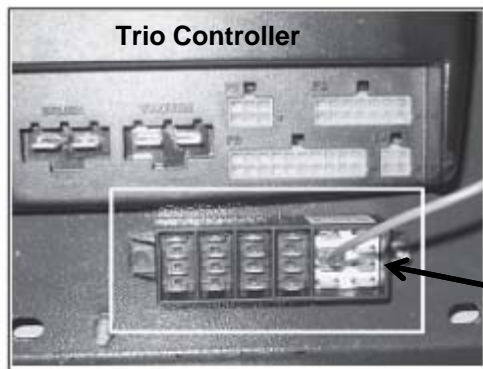

SCV 2832E Shown

## Trio Pressure Settings

### 748174 SCV2832E

Setting	Disk Pressure	Amps	Orange/violet Wire
1	Light Disk	30	Not connected
2	Double Both	40	Not connected
3	Heavy Disk	50	Not connected
4	Light Cylindrical	23	Connected
5	Heavy Cylindrical	30	Connected

### 748206 SCV2426

Setting	Disk Light Pressure	Amps	Orange/violet Wire
1	Light Disk	23	Not connected
2	Double Both	28	Not connected
3	Heavy Disk	28	Not connected
4	Light Cylindrical	23	Connected
5	Heavy Cylindrical	26	Connected

### 747010 ES2832

Setting	Disk Light Pressure	Amps	Orange/violet Wire
1	Light Disk	30	Not connected
2	Double Both	40	Not connected
3	Heavy Disk	40	Not connected
4	Light Cylindrical	17	Connected
5	Heavy Cylindrical	25	Connected

## 4.1 ES2832, CP2832, and Phoenix 34

It is now available to change the brush pressure settings in the field, when changing brush decks on current production models of the Easy Scrub 28 and 32. No other modifications will be required.

Changing the brush pressure settings will only be required, when changing the cylindrical over to the disk deck or disk over to the cylindrical decks. Changing the size only (Example: Changing the 28 disk to 32 disk) will not require changing the settings.

The orange/violet wire from the controller has been added to change settings.

Connecting the orange/violet wire to the terminal block puts it in the low-pressure mode for cylindrical decks.

Disconnecting the orange/violet from the terminal block puts the brush pressure in the high-pressure mode for disk decks.

### Instructions:

1. Remove the switch panel, by removing the four screws.
2. Locate the terminal block. See Photograph.

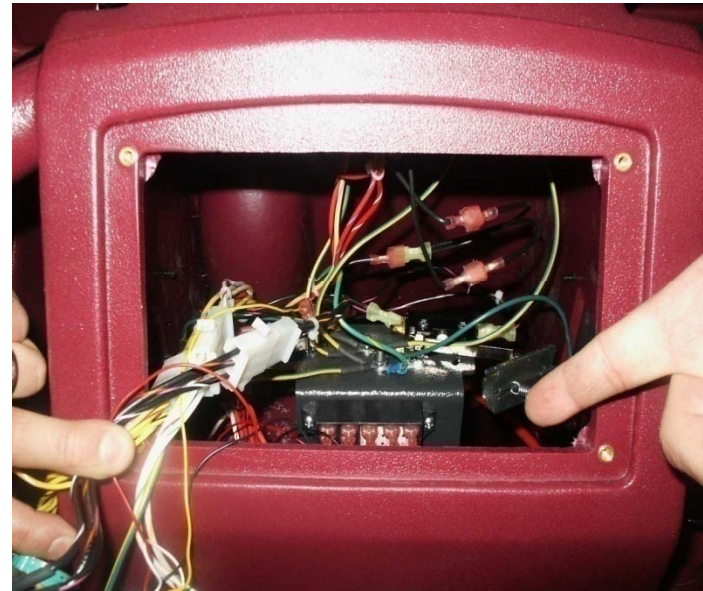

## 4.2 ES2832,CP2832, and Phoenix 34



Locate the Red/Black wire group

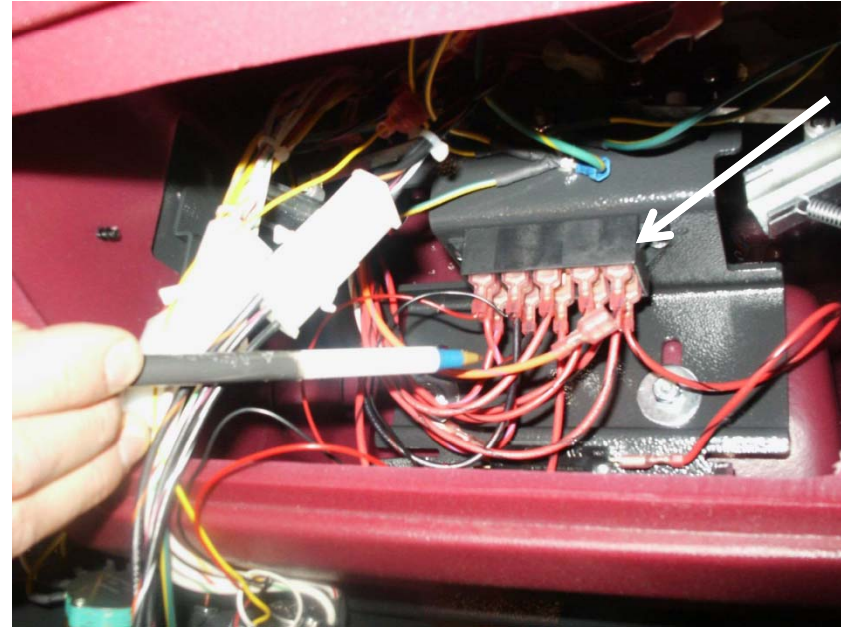

Locate the Orange/Violet wire

# 5. Error Codes

The model SC280000 Rider scrubber uses a LCD display mounted above the steering wheel which indicates the error code when they occur. The will be displayed as a four digit code with a picture of a wrench next it. The top three are the hour meters for Total Time, Brush Motors and Drive Motor.



The SC2832E, SC2426P, ES2862 and CP2832 models uses a 10 light LED display to indicate the battery condition a error codes. The battery condition will be displayed with 1 to 10 LEDS. 10 LEDS would be a fully charged battery one LED batteries are discharged.

When a error occurs 1 to 10 LEDS will flash indicating a specific error has occurred. There are two aspects of the error codes.

- A. How many LEDS are flashing
- B. How many times it is flashing ( referred to as sequence)

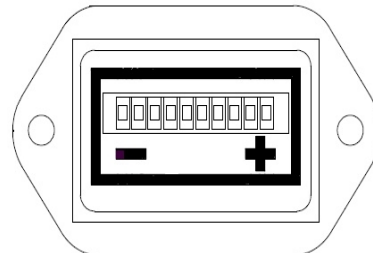



# 6. Table of Error Codes



Code	Information or Fault Description	Comments and Corrective Action
0810	TILLER FAULT-1	For all Throttle Potentiometer Circuit Diagnostic Codes:
0811	TILLER MAX WIPER DIFFERENCE ERROR	1- Check throttle wiring for shorts or opens. Repair or replace as necessary.
0812	TILLER MAX PULL DOWN DIFFERENCE ERROR	2- If Diagnostic Code is not cleared, then replace throttle.
0813	TILLER MAX PULL SAFE DIFFERENCE ERROR	" " " "
0814	TILLER REFERENCE ERROR	Throttle displaced during start up. Check throttle springs (Riders) or drive switches (ES or CPs)
0815	TILLER LO REFERENCE ERROR	1- Check throttle wiring for shorts or opens. Repair or replace as necessary.
0816	TILLER HI REFERENCE ISO ERROR	2- If Diagnostic Code is not cleared, then replace throttle.
0817	TILLER LO REFERENCE ISO ERROR	" " " "
0818	TILLER ERROR BOTH HAVE READINGS	" " " "
1310	EXCESSIVE CURRENT TRIP	Current draw of all output devices connected to TRIO+ exceeded 250 amp maximum limit.
1311	SOFT AUX1 OVERCURRENT OCCURRED	Brush Actuator on Aux-1 exceeded 21 amp max. current limit. Check wiring or replace device.
1312	SOFT AUX2 OVERCURRENT OCCURRED	Squeegee Actuator on Aux-2 exceeded 21 amp max. current limit. Check wiring or replace device.
1313	SOFT AUX3 OVERCURRENT OCCURRED	Water Pump on Aux-3 exceeded 7 amp max. current limit. Check wiring or replace device.
1314	SOFT AUX4 OVERCURRENT OCCURRED	Water Solenoid on Aux-4 exceeded 7 amp max. current limit. Check wiring or replace device.
1318	SOLUTION TANK EMPTY	Solution Tank Empty signal from float switch
131C	SOFT ALARM OVERCURRENT OCCURRED	Alarm circuit exceeded 2 amp max. current limit. Check wiring or replace device.
1321	AUX1 OVERCURRENT 2 OCCURRED	Device connected to Aux-1 exceeded 12 amps for > .1 sec Check Brush Actuator.
1322	AUX2 OVERCURRENT 2 OCCURRED	Device connected to Aux 2 exceeded 12 amps for > .1 sec. Check wiring or replace device.
1411	ERROR AUX 1 POSITIVE SHORTED_LOW	Check Brush Actuator Motor and wiring. Repair or replace as necessary.
1412	ERROR AUX 1 NEGATIVE SHORTED_LOW	Check Brush Actuator Motor and wiring. Repair or replace as necessary.
1413	ERROR AUX 2 POSITIVE SHORTED_LOW	Check Squeegee actuator and wiring. Repair or replace as necessary.
1414	ERROR AUX 2 NEGATIVE SHORTED_LOW	Check Squeegee actuator and wiring. Repair or replace as necessary.
1500	BRAKE FAULT OPEN CIRCUIT	Check Electric Brake circuit for a faulty connection.
1501	BRAKE FAULT 2	Check Electric Brake circuit for a faulty connection.
1507	BRAKE OVER CURRENT ERROR	Check Brake circuit wiring and brake. Repair or replace as necessary.
1600	HIGH BATTERY ERROR	Battery is overcharged or damaged. Replace battery.
1D02	FRONT END SPEC CHANGE TRIP	Drive parameters have been reprogrammed. Cycle power with key switch.
1E03	INHIBIT ACTIVATED	Solution Tank Empty - Check float switch
1E04	INHIBIT ACTIVATED2	Recovery Tank Full - Check float switch
1E06	INHIBIT INPUT OUT OF RANGE	Invalid Inhibit signal. Check wiring and device. Repair or replace as necessary.

## 6. Table of Error Codes

2C00	LOW BATTERY ERROR	Battery Charge to low. Recharge battery.
2C01	LOW BATTERY ERROR2	Battery Charge to low. Recharge battery.
2C02	SOFT BATTERY LOCKOUT OCCURRED	Battery Charge to low. Recharge battery.
2C03	SOFT BATTERY LOCKOUT 2 OCCURRED	Battery Charge to low. Recharge battery.
2F01	TILLER DISPLACED ERROR	Throttle displaced on Power-up. Release throttle and then re-engage throttle.
3A00	BAD SETTINGS	Illegal program parameter settings.
7000	STARTUP WITH PUSH SELECTED	Freewheel Input signal detected at startup. Disconnect Freewheel input.
7001	PUSH ACTIVATED IN DRIVE MODE	Freewheel Input signal activated while driving. Disconnect Freewheel input.
7500	TILLER COMMS TIMEOUT	Problem with LCD Module or wiring. Repair or replace as necessary.
7600	SOFT BRUSH MOTOR DISCONNECTED ERROR	Check Brush Motor wiring and connectors
7601	SOFT BRUSH CURRENT FOLDBACK	Too much Brush Pressure/Current. Check for jammed Brushes or Deck or Brush motor short.
7602	SOFT BRUSH CURRENT FOLDBACK2	Too much Brush Pressure/Current. Check for jammed Brushes or Deck or Brush motor short.
7603	SOFT BRUSH CURRENT FOLDBACK3	Too much Brush Pressure/Current. Check for jammed Brushes or Deck or Brush motor short.
7604	SOFT BRUSH INHIBIT	Brush Inhibit signal is active.
7605	BRUSH STARTUP OVERCURRENT DETECTION	Possible Brush motor problem or shorted brush circuit wiring.
7700	SOFT VACUUM MOTOR DISCONNECTED ERROR	Check Vacuum Motor wiring and connectors
7701	SOFT VACUUM CURRENT FOLDBACK	Too much Vac motor current. Check for shorted Vac motor or wiring.
7702	SOFT VACUUM CURRENT FOLDBACK2	Too much Vac motor current. Check for shorted Vac motor or wiring.
7703	SOFT VACUUM CURRENT FOLDBACK3	Too much Vac motor current. Check for shorted Vac motor or wiring.
7800	TRACTION MOTOR FAULT-1	Check Traction Motor wiring and connectors
7801	TRACTION MOTOR OVER CURRENT ERROR	Too much Traction motor current. Check for shorted Traction motor or wiring.
7802	TRACTION MOTOR IN FOLDBACK STATE	Traction Motor was overloaded for too long, Control limiting current to protect motor.
7803	MOTOR LINE VOLTAGES INSTABILITY TIMEOUT	Possible Traction Motor or loose wiring problem.
7804	TRACTION MOTOR IN DRIVE BOOST	Traction Motor under heavy load or Current Limit / Fold back parameters set too low.
7880	TRACTION SPEED INPUT OUT OF RANGE	Check Throttle Potentiometer and wiring.
7900	EMERGENCY STOP ERROR	Emergency Stop function activated.
7901	SOFT BELLY BUTTON ACTIVATED	Safety Bar switch is activated. (ES and CP models only)
8000	SERVICE MODE	Service Timer limits have been reached.
9000	BRUSHES NOT FITTED	Check Brush Deck to make sure Brushes are fitted properly.

# 6. Table of Error Codes



0003		For All of these Diagnostic Codes:
0100		1- Turn Off Key switch and disconnect batteries.
0204		2- Wait 1 minute.
0705		3- Reconnect Batteries and turn on key switch.
0706		4- If Diagnostic Code is not cleared, then replace TRIO+ / TRIO+HD control.
0A01		
0B02		<b>IMPORTANT!</b>
0B0B		TRIO+ / TRIO+HD can be damaged internally by shorting Batt+ to any of it's Inputs or Outputs.
		Check Wiring Harness for shorts before installing a replacement Control.
1704		If replacement control fails, then replace Wiring Harness before installing any more Controls.
1705		
1706		
1800		
1802		
1B20		
1B21		
2102		
2103		
2D01		
3100	Shorted Circuit	Check For Shorts on the Brush and Drive Motor Circuits. Also Water inside of motors.
3101		
3102		
3103		
3104		
3105		
3200		
3201		
3210		
3211		

# 6. Table of Error Codes



3212		<b>For All of these Diagnostic Codes:</b>
3213		1- Turn Off Key switch and disconnect batteries.
3214		2- Wait 1 minute.
		3- Reconnect Batteries and turn On Key switch.
3601		4- If Diagnostic Code is not cleared, then replace TRIO+ / TRIO+HD control.
3602		
3603		
3608		
3609		<b>IMPORTANT!</b>
360A		TRIO+ / TRIO+HD can be damaged internally by shorting Batt+ to any of it's Inputs or Outputs.
360B		Check Wiring Harness for shorts before installing a replacement Control.
360C		If replacement control fails, then replace Wiring Harness before installing any more Controls.
360D		
360E		
7501		

# 5.1 Table Error Codes (LED)



Single flash Low Batteries- Charge the batteries



Single flash Traction drive motor disconnected



Single flash - Brush motor disconnected



Single flash - Brush actuator overload

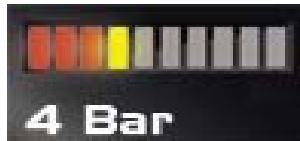

Two flash – Squeegee actuator overload

## 5.1 Table Error Codes (LED)



Single flash – Vacuum motor disconnected



Single flash- Off Isle Wand Activated



Single flash- Potentiometer fault



Single flash- Control fault check all connections to controller- see "Trouble Shooting the Code 8 Error"

## 5.1 Table Error Codes (LED)



Single Flash- Solution tank empty- Riders only



Two flash-Not used



Three flash-Water solenoid fault



Four flash-Water pump fault



Five flash-Electric brake circuit fault- Check all connection to the brake.

# 5.1 Table Error Codes (LED)



Single flash- High battery voltage- Check all connections

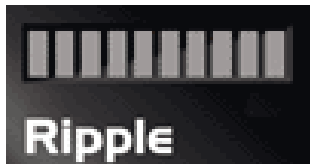

Ripple-Throttle activated during start up.



## 6. Side Squeegee Adjustment

SCV2426 & SCV2832E Only

The side squeeeges on the cylindrical decks can be adjusted by loosening the two black knobs and moving the squeegee assemble up or down.

The brush assembly may be accessed by removing the yellow knob C. The squeegee assembly is hinged at D.

Remove the three wing nuts that mount the brush idler bearing assembly E and remove the brush roll.

Repeat the process on both sides of the machines

Cylindrical Decks

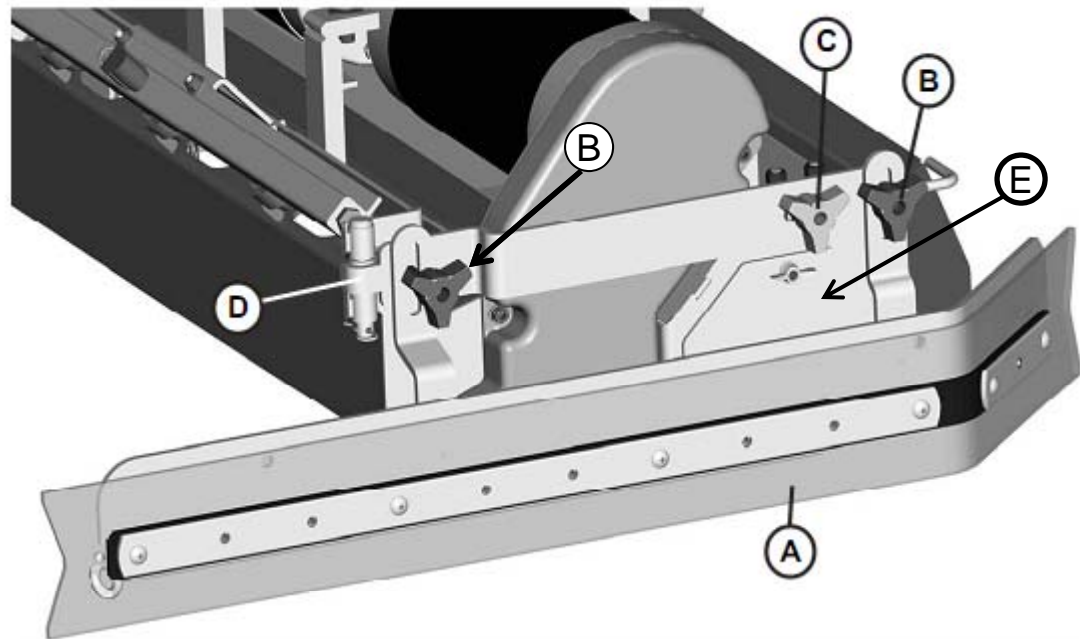

- A-Side Squeegee
- B-Black Adjustment Knob
- C-Yellow Brush Access Knob
- D-Side Squeegee Hinge
- E-Bush Access Plate

# 6.1 Side Squeegee Adjustment

SCV2426 & SCV2832E Only

The side squeegee assemblies can be adjusted by loosening the two wing nuts and moving the assembly up or down.

Repeat the process on both sides, if needed.

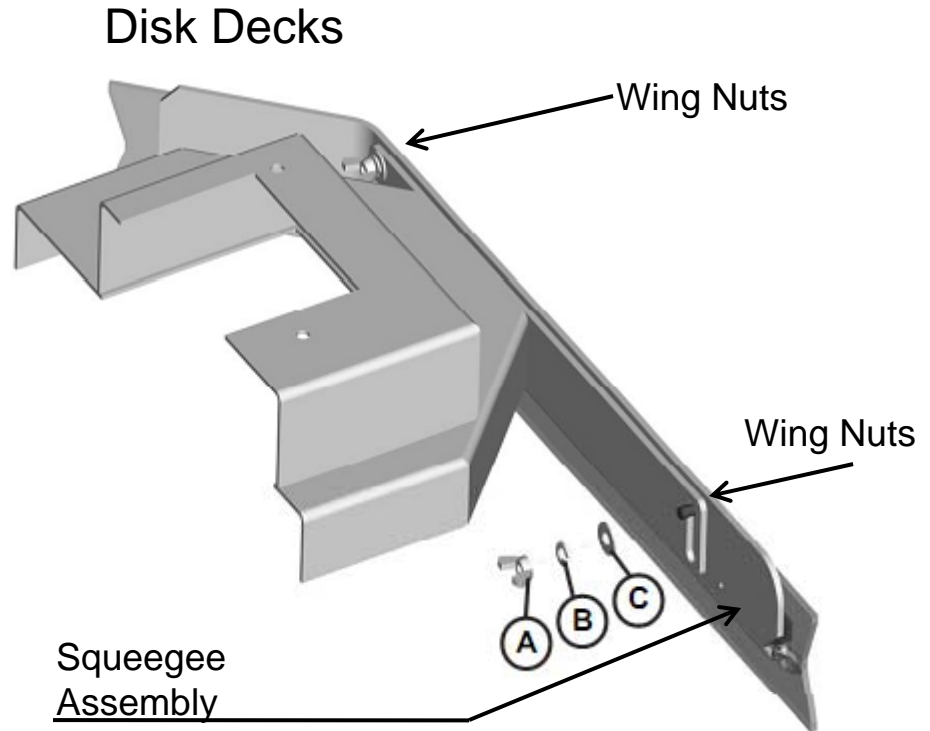

A	Wing Nut for Squeegee Adjustment (2)
B	Helical Lock Washer for Squeegee Adjustment (2)
C	Flat Washer for Squeegee Adjustment (2)

## 7. Squeegee Adjustment

Later Models Only

- The pitch of the squeegee can be adjusted by turning the knob. Loosen the wing nuts before adjusting. Tighten the wing nuts to lock into position.

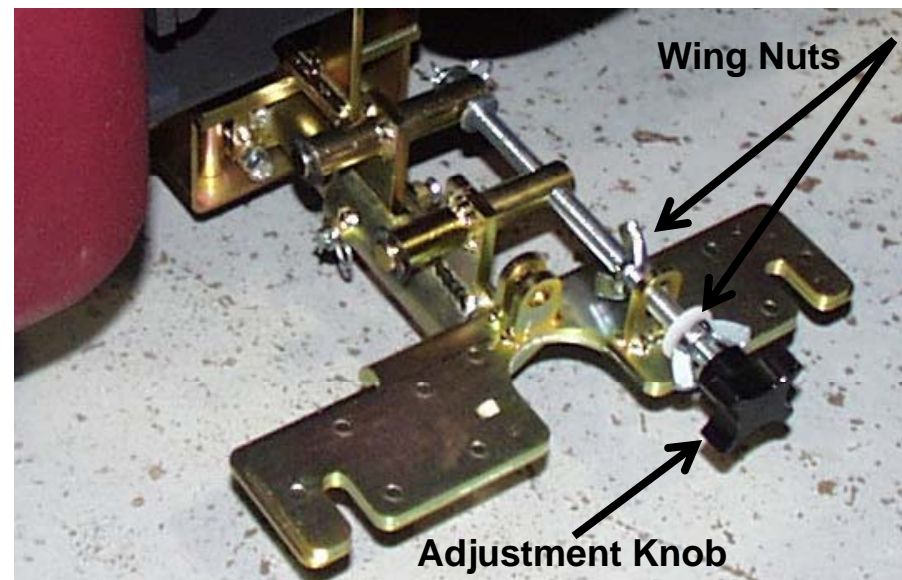

# 7. Rear Squeegee Adjustment

Later Models Only

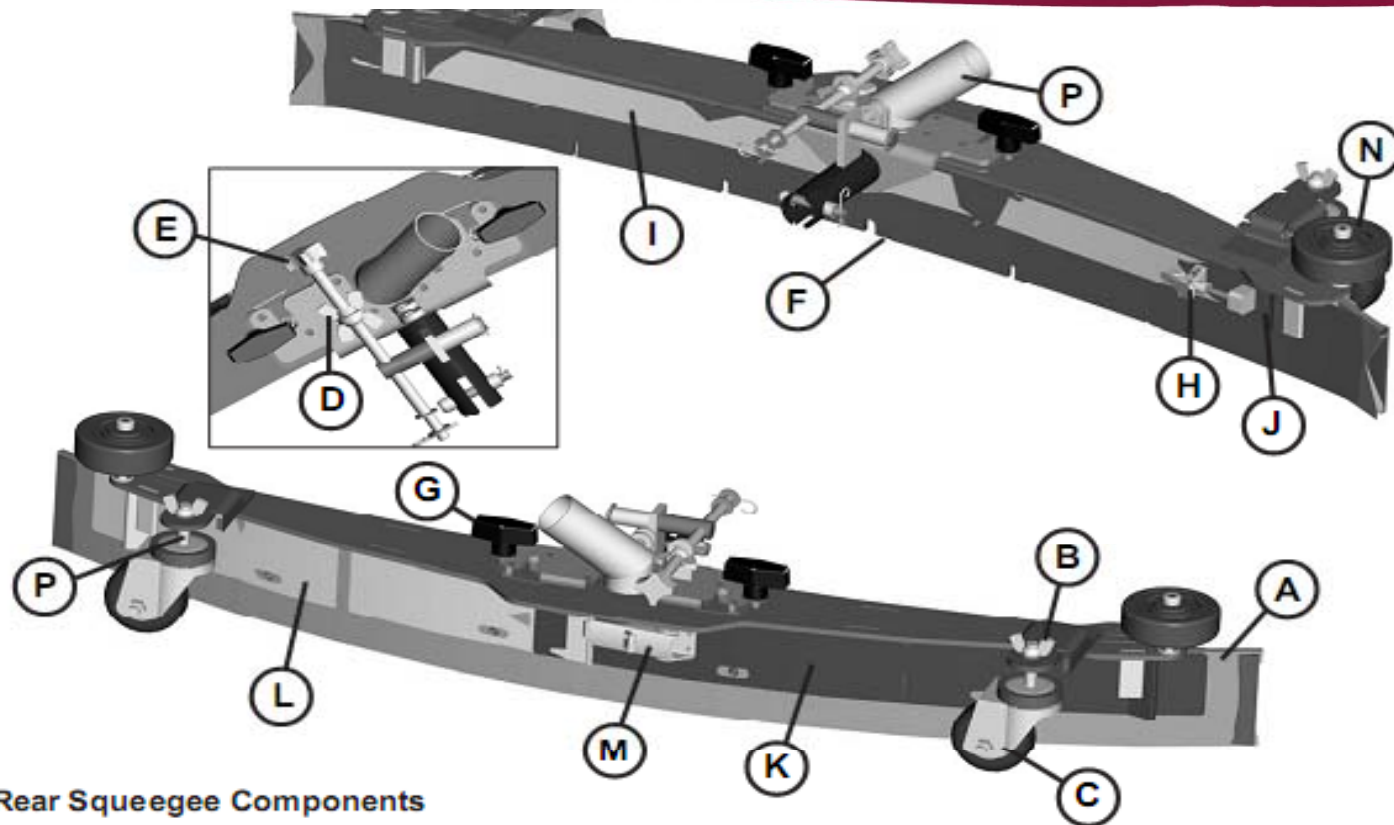

Rear Squeegee Components

A	Rear squeegee blade	I	Front strap (long)
B	Wing jam nut (2)	J	Front strap (short)
C	Swivel Caster (2)	K	Rear strap (latch side)
D	Wing Jam Nut	L	Rear strap (catch side)
E	Turnbuckle Adjustment Knob	M	Latch
F	Front squeegee blade	N	Guide wheels (2)
G	Wing bolt (2)	O	Recovery hose intake
H	Toggle clamp	P	Treaded Stem

## 7. Rear Squeegee Adjustment

### Later Models Only

1. Ensure that the scrubber is on a relatively flat surface. Turn on the key switch and select the **Vacuum only** mode. This lowers the squeegee to the floor and turns the vacuum motor on.
2. Move the scrubber one or two feet forward slowly while someone behind the machine checks the rear squeegee blade (item **A**) for uniform deflection to the floor.
3. If uneven deflection or lay is evident, minor adjustments may be necessary to avoid streaking and uneven wear on the blade.
4. To correct this, loosen the wing jam nut (item **B**) in order to adjust the caster height. If the squeegee blade is deflecting too much, the casters (item **C**) need to be lowered to control the down pressure. Lower the caster by turning the exposed threaded stem (item **P**) on the caster clockwise. Make the adjustment a few turns at a time. **Repeat step 2.**
5. If the blades are not deflecting enough, raise the caster by turning the stem counter-clockwise to adjust the caster height to allow more down pressure on the squeegee. **Repeat step 2.**
6. Make sure there is even deflection on the entire length of the rear blade. Adjust the casters and retighten the wing jam nuts to lock the caster setting in place.
7. Pitch adjustment is necessary if the outer ends on the squeegee blade do not contact the floor and there is too much deflection in the middle area or if the outer ends are over deflected and there is no contact in the middle.
8. To adjust the pitch, Repeat step 2.
9. Loosen the two wing jam nuts (item **D**) that lock the pitch angle. Turning the knob (item **E**) clockwise or counter-clockwise controls the forward and backward pitch of the squeegee. Having the rear blades deflected uniformly along its entire length is the desired set-up.
10. Repeat step 2 until desired set-up is achieved.
11. In certain applications where a non-slotted front wiper blade (item **F**) is needed, detach the rear squeegee assembly by loosening the two wing bolts (item **G**). Unlock the toggle clamp (item **H**) on the front squeegee to release the front long strap (item **I**) and slide the front short strap (item **J**). Flip the blade over to the non-slotted side. Reattach the straps and lock the clamp back in place.
12. You can also easily replace the rear blade by unlatching the latch (item **M**) and removing the two rear straps (items **K & L**) by sliding them off the assembly. You can then flip the blade over in order to use a new edge for better wiping action.

## 8. Replacing the Brush Actuator on the SCV 28 or 32

All Versions Of SCV2832E and SC280000



### Replacing the Brush Actuator on the SCV 28 or 32

1. Lower the brush deck, so it gently rests on the floor.
2. Remove the side squeegees.
3. Remove the four bolts that mount the deck to the lift linkage.
4. Unplug the electrical connector and the Quick Connector for the solution from the deck.
5. Slide the deck out from under the machine.
6. Unplug the electrical connector to the actuator motor.
7. Remove the two pins that mount the actuator on each end.
8. Remove the actuator from the machine.
9. Mount the new actuator. Do not connect the electrical connector on the actuator at this point.
10. Connect the battery pack.
11. Turn the machine on.
12. Put the machine in Service Mode. Hold one of the brush pressure buttons on the touch pad for over 20 seconds and release on the model SC280000. The SC28/32E's service mode switch is located in the controller compartment under the seat, on the operators left side. Push the rocker switch in the down position for 20 seconds.
13. Connect the actuator electrical connector into the harness.
14. Use the up and down buttons on the touch pad to adjust the brush linkage height, so that you can slide the brush deck into position. Do not raise it all the way up, until it is set correctly.
15. Lower the linkage down, using the touch pad or rocker switch, so that it gently rests on the mounting brackets.

## 8. Replacing the Brush Actuator on the SCV 28 or 32



All Versions Of SCV2832E and SC280000

16. Slide the brush deck into position, install the four mounting bolts and tighten. Connect the brush motor connector and solution quick connector.
17. Locate the black rubber removable plug on the right side of the actuator and remove.
18. For models with cylindrical decks only. Remove the plastic side deck cover on the operators left side. This is a gray plastic piece screwed to the side of the solution tank above the deck area.
19. Use the brush pressure up button to raise it up a little at a time. The clearance between the top belt cover and the under side of the tank should be between 1/4 to 3/8 inch, when the deck stops rising up. Do not allow it to rise any higher or it might over load the actuator. If it continues to rise higher, adjustment will be required.
20. For Disk machines only, the actuator should be set so that you can slide the brushes under the deck and not bottom out under the machine.
21. Adjust the actuator adjustment screw to change setting see drawing. Turn the screw no more than 1/8 of a turn at a time. The adjustment screw closest to the shaft controls how high it rises. The screw furthest from movable controls maximum down pressure. Look at the rubber plug to determine which way to turn the screw.
22. Lower the brush deck and return it back up for the new settings to change.
23. Adjust the down setting so that the actuator cannot lift the drive motor off the floor. Set it so it only lifts some pressure off the drive wheel.
24. Once the correct setting is made replace the rubber plug into the side of the actuator motor.
25. Replace side plastic cover.
26. Turn the key switch off and back on.
27. Test the machine.

# 8.1 Actuator Adjustment

## Actuator Adjustments

### SCV 28/32 Actuator Adjustment

7/32" Hex

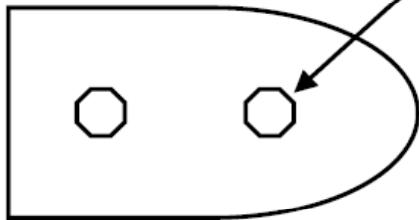

Turning this screw counterclockwise  
increases the lifting height of the deck.  
(Raises it higher up)

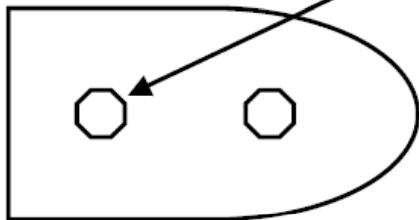

Turning this screw counterclockwise  
decreases the lowering height of the deck.  
(Does not go down as far)



## 8.2 Entering Service Mode with a Stuck Actuator

### To enter service mode with a stuck actuator:

- With the machine off, unplug the **P2 connector**.
- Turn it on and press and hold the service switch up to 30 seconds.
- Plug the **P2 connector** back in. ( Leave machine on)
- Press the service mode switch to raise and lower the brush deck.

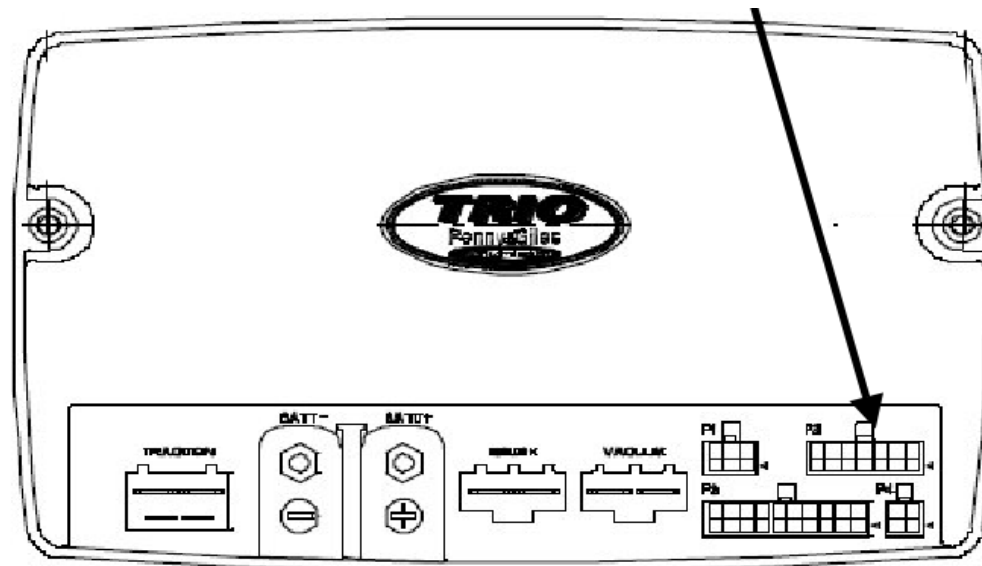

## 9. Trouble Shooting the Code 8 Error

### **ES2832, CP2832, SCV2426 and SC2832E Models Only)**

1. Check for loose or burnt connections on the controller, batteries, cables and the circuit breaker. Make the sure the circuit breaker is not damaged.
2. Measure the total battery voltage at the batteries and at the battery connections on the controller. They should be exactly the same. A 1/10 of a volt or more difference would indicate a problem in the connections.
3. Check to see, if the operator has recently washed the machine down and got water inside of the brush motor or in the controller area.
4. On the ES2832 and CP2832 only disconnect the plug on the Service Mode Switch. This is accessible by tilting the solution tank forward. Power the machine up with it disconnected. If error code is cleared replace the switch.
5. Check for a disconnected or an open circuit or faulty potentiometer on the throttle or speed circuit. Controller may not be detecting it in the circuit. Do a continuity test. See “Testing the potentiometer” section.

## 9. Trouble Shooting the Code 8 Error



6. Disconnect one motor connector from the Trio controller at a time and disconnect the batteries for 1 minute and restart the machine. If the code 8 disappears and is replaced by a different code, the circuit disconnected should be considered suspect. For example the brush was disconnected. The code 8 is replaced by code 3. Code 3 indicates the brush motor is disconnected. Check for a loose or broken connection at the brush deck. Check to see if water has gotten inside the brush motor. Check for a shorted motor.
7. Static electricity. Check both the ground chains; there is one on the brush deck and one on the rear of the machine. They should be contacting the floor. The one on the deck should touch the floor when the deck is down. They also should have continuity between the end of the chain and the frame of the machine. Repair or clean if needed if needed.
8. If everything checks OK, replace the Trio Controller.

**Note controllers can be damaged by loose connections on inputs and outputs, static electricity and water on electrical components such as on or in the controller and motors.**

# 10. Testing the Throttle Potentiometer

1. The throttle potentiometer resistance can be measured with an ohmmeter.
2. Unplug the throttle potentiometer at the connector next to it.
3. *Analog type meters are recommended for this test.*
4. Measure the resistance across the red and white wire on the potentiometer assembly. It should measure approximately 5K (5 thousand ohms).
5. Measure across the black and white wires on the potentiometer, the resistance should be zero ohms with pedal on the riders in the neutral position or speed knob on the ES2832 and CP2832 in the full counterclockwise position. When the pedal or knob is moved to the full throttle position, it should be a smooth resistance change without dropping out. It should measure approximately 5K (5 thousand ohms) in the full position.
6. Measuring across the black and the red wire the resistance should be approximately 5K (5 thousand), when in the neutral position. When the pedal is at full throttle or the knob is full speed position, the resistance should drop to zero.
7. If adjustment is needed, loosen the nut and screw on the throttle arm. Adjust the potentiometer shaft with a flat tip screw driver, until it is set according to the information above (on the riders only).

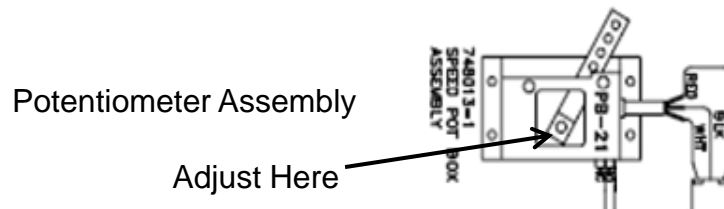

# 10. Testing the Throttle Potentiometer



8. If they do not find a problem here, have them retest at the connector at the Trio controller.
9. Reconnect the plug at the throttle potentiometer.
10. Unplug the P3 connector (The large white connector) on the controller under the seat on the riders and behind the two rear panels on the ES2832s and CP2832s.
11. Locate the black/orange and the black/pink wire.
12. Measuring across the black/orange and black/pink wires the resistance should be zero ohms in the neutral position. It should 5k in the full throttle position.
13. Measure across the black/pink and the black/white wires. The resistance should be 5K (5 thousand) in the neutral position. When the pedal is at full throttle the resistance should drop to zero.
14. If your reading is different with this test check all the connections between the controller and the throttle control, including the seat switch.

**Note: when moving the throttle to the full position, the resistance should be smooth, without dropping out for both tests. If the resistance does not go to 5K during the test, the arm and the potentiometer may need to be adjusted to achieve it.**

# 11. Identifying the Cause of Trio Failures



1. Check for loose or burnt connections on the controller, batteries, cables and the circuit breaker. Make the sure the circuit breaker is not damaged (burnt or cracked).
2. Test the chassis drive motor harness for broken wires (riders only). Disconnect the plug labeled Traction on the Trio controller. Connect a digital multi-meter to the plug on the two large wires. Set the meter for Ohms (resistance). The resistance should be .3 to .4 ohms. Turn the steering wheel in both directions until it stops several times. Monitor the meter while turning. The resistance should not change or vary while turning. Any variation even .1 ohm would be indicate a broken wire, which could cause spikes and surges, that could damage the Trio controller.
3. Measure the total battery voltage at the batteries and at the battery connections on the controller. They should be exactly the same. A 1/10 of a volt or more difference would indicate a problem in the connections.

# 12. Notes

