

Eagle Power™

Products Group

SK20

AUTOMATIC

SCRUBBER



ENTER 

PARTS MANUAL



Click on icon to return to this page.

← Back 1 page

SK 20 AUTOMATIC SCRUBBER CODE: PF02240NTG-4 aa SN from 01B600

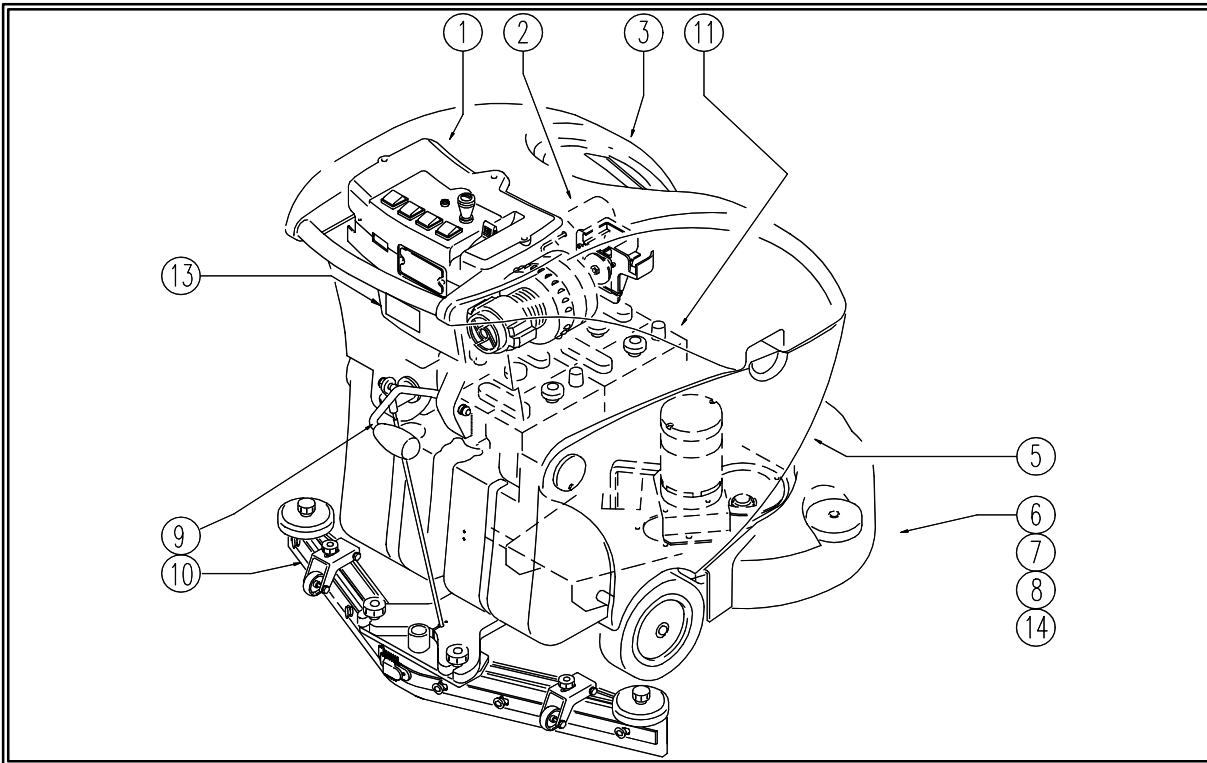

REF.	CODE	DESCRIPTION	QTY
1	PL1011	CONTROL PANEL	
2	PL1001	SUCTION UNIT	
3	PL1012	TANK	
5	PL1004	TANK	
6	PL1005	BRUSH AXLE	
7	PL1014	MOTOR	
8	PL1015	WHEELS	
9	PL1008	SQUEEGEE LIFT AND SUPPORT	
10	PL1010	SQUEEGEE	
11	PL1016	BATTERY	
13	PL1043N	EXTERNAL PARTS	
14	PL1278	BRUSHES	
	PL1074N	PACKING	
	WD27190	ELEC. WIRING DIAGRAM	
	WD27190-1	ELEC. SCHEMATIC DIAGRAM	



← Back 1 page

SK 20 AUTOMATIC SCRUBBER CODE: pl1011 ae SN from 01B600

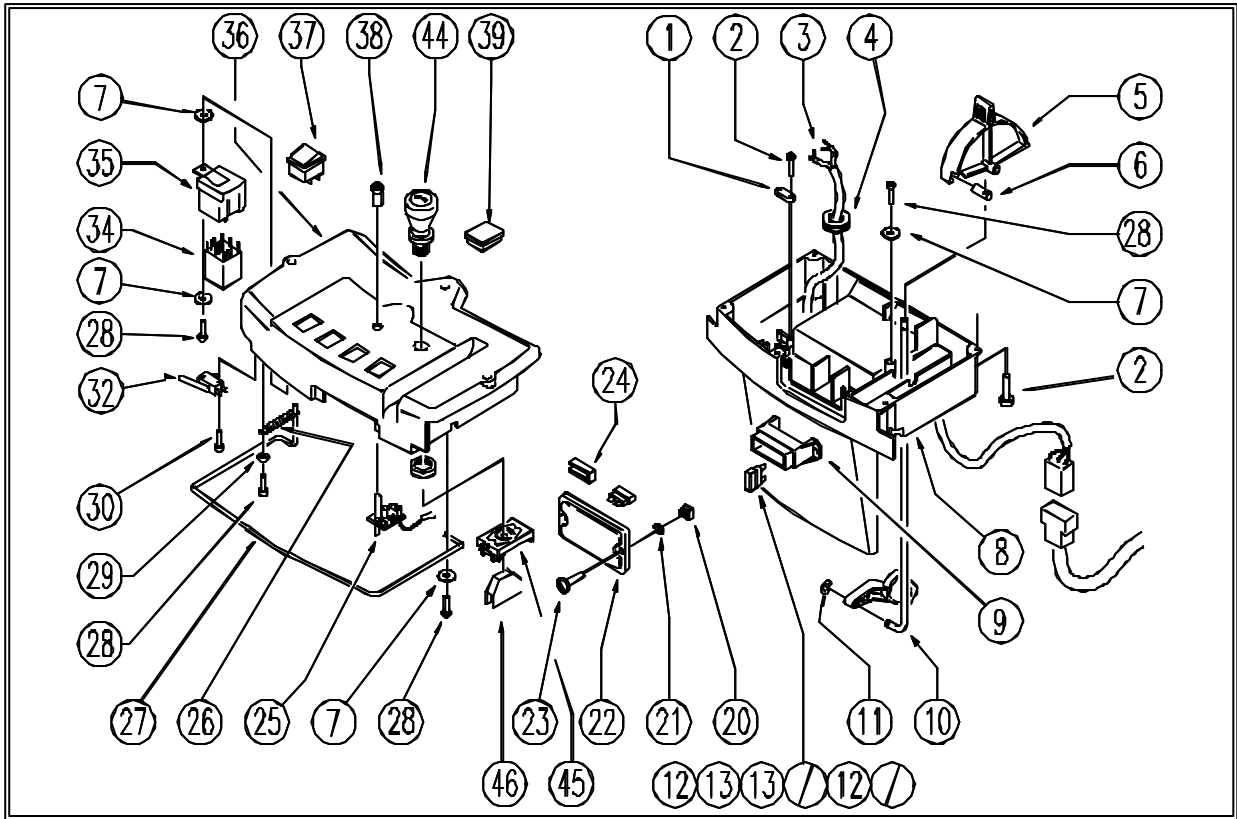

SK 20 AUTOMATIC SCRUBBER CODE: pl1011 ae SN from 01B600

REF.	CODE	DESCRIPTION	QTY
	GR23632-4	PREASSEMBLED CTRL PANEL	1
1	SL09908	CABLE CLAMPING STAPLE	1
2	SL04187	SCREW	6
3	SL23632-1	WIRING	1
4	SL23695	FAIRLEAD	1
5	SL17490-1	LEVER	1
6	SL09808	ARTICULATION	1
7	SL06014	WASHER	4
8	SL17489-1	CONTROL PANEL	1
9	SL23894	FUSE CARRIER	1
10	SL09805	ROD	1
11	SL11113	SEEGER	1
12	SL23144	FUSE	4
13	SL23148	FUSE	4
20	SL05077	NUT	2
21	SL03116	GASKET	4
22	SL17149-1	LID	1
23	SL04377	SCREW	2

Next page →



← Back 1 page

SK 20 AUTOMATIC SCRUBBER CODE: pl1011 ae SN from 01B600			
REF.	CODE	DESCRIPTION	QTY
24	SL23209	FUSE TWEEZERS	1
25	SL23031	BOARD / CARD	1
26	SL13116	SPRING	1
27	SL09795	LEVER	1
28	SL04327	SCREW	4
29	SL06019	WASHER	1
30	SL04214	SCREW	2
32	SL23109	MICROSWITCH	1
34	SL23719	RELAIS	1
35	SL23722	RELAIS SUPPORT	1
36	SL17488-1	CONTROL PANEL	1
37	SL23183	SWITCH	2
38	SL23031-1	REFLEX REFLECTOR	1
39	SL23570	SWITCH COVER	2
44	SL23954	EMERGENCY SWITCH	1
45	SL23955	CONTACT CARRIER	1
46	SL23956	CONNECTION	2



← Back 1 page

SK 20 AUTOMATIC SCRUBBER CODE: pl1001 ae SN from 01B600

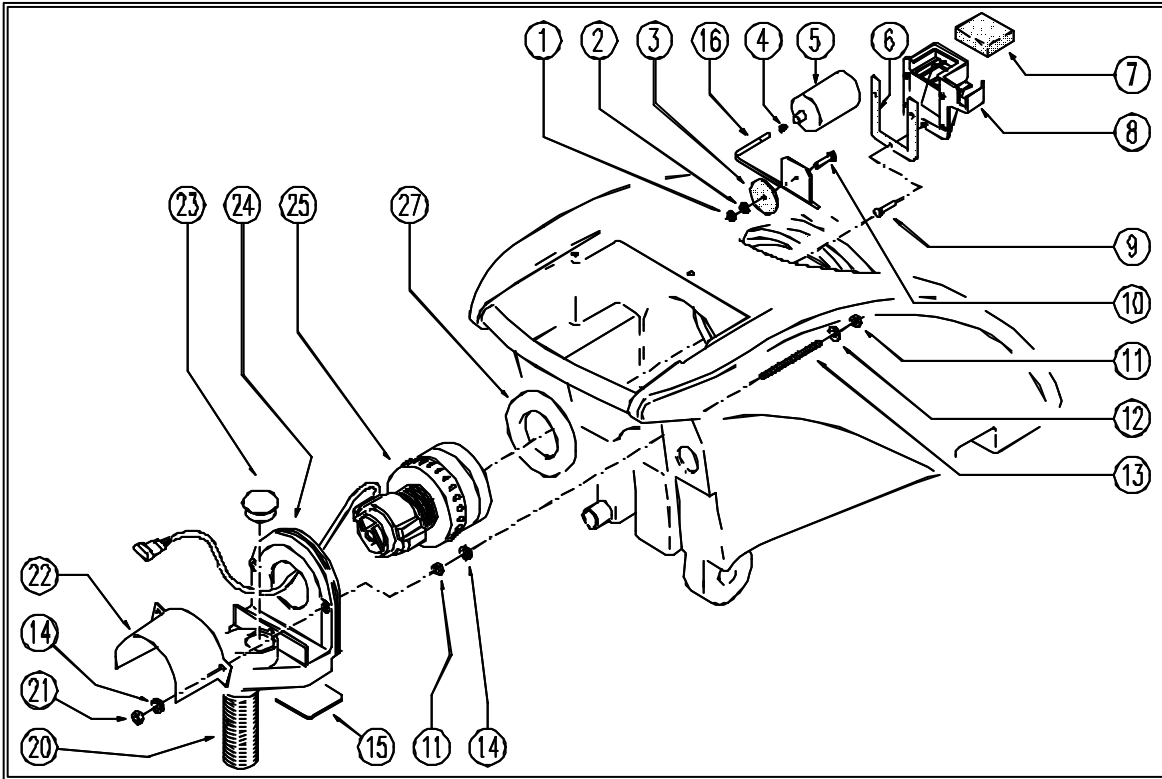

REF.	CODE	DESCRIPTION	QTY
1	SL05087	NUT	1
2	SL06038	WASHER	1
3	SL03346	GASKET	1
4	SL04388	INSERT	1
5	SL18393	FLOAT	1
6	SL03429	GASKET	1
7	SL03345	FILTER	1
8	SL17492-1	SUPPORT	1
9	SL04095	SCREW	3
10	SL04310	SCREW	1
11	SL05017	NUT	4
12	SL06071	WASHER	2
13	SL04276	SCREW	2
14	SL06022	WASHER	4
15	SL17554	BULKHEAD	1
16	SL09827	ROD	1
20	SL19248	PIPE	1
21	SL05041	NUT	2
22	SL03514	SUCTION CONVEYOR	1
23	SL14240	CAP	1
24	SL03297	CAP / SHELL	1
25	SL02303-J	EXHAUSTER / ASPIRATOR	1
27	SL03033	GASKET	1



← Back 1 page

SK 20 AUTOMATIC SCRUBBER CODE: pl1012 ah SN from 01K187

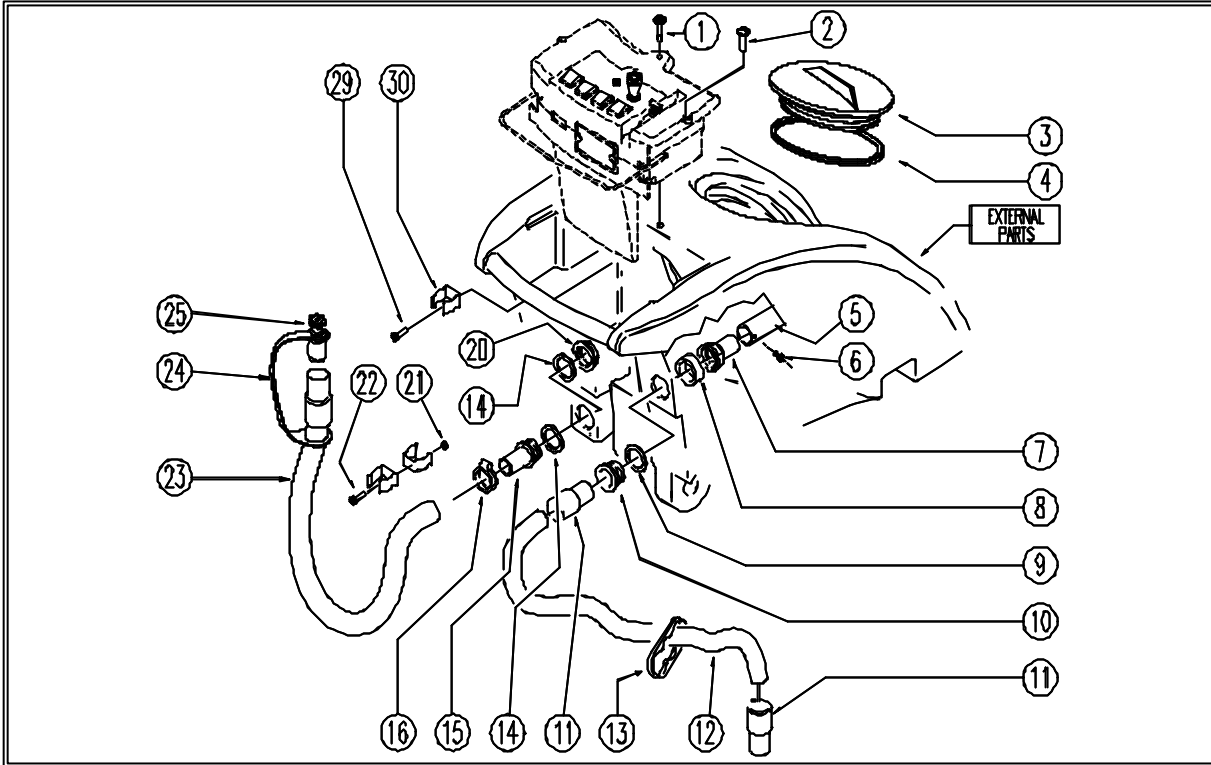

REF.	CODE	DESCRIPTION	QTY
1	SL14162	KLIP	1
2	SL04377	SCREW	2
3	SL17468	COVER	1
4	SL03487	GASKET	1
5	SL07420	HOSE	1
6	SL04325	SCREW	1
7	SL18349	CONNECTOR	1
8	SL07546	SPACER	1
9	SL03416	GASKET	1
10	SL18355	SUCTION OPENING	1
11	SL14003	SLEEVE	2
12	SL19021	HOSE	1
13	SL03437	PLAQUE	1
14	SL03441	GASKET	2
15	SL18350	CONNECTOR	1
16	SL14063	CLAMP	1
20	SL05075	NUT	1
21	SL05044	NUT	2
22	SL04032	SCREW	2
23	SL19113-5	HOSE	1
24	SL03577	CLAMP	1
25	SL18395	KNOB	1
29	SL04371	SCREW	2
30	SL13118	DUCT LOCK	3



← Back 1 page

SK 20 AUTOMATIC SCRUBBER CODE: pl1004 ah SN from 01K430

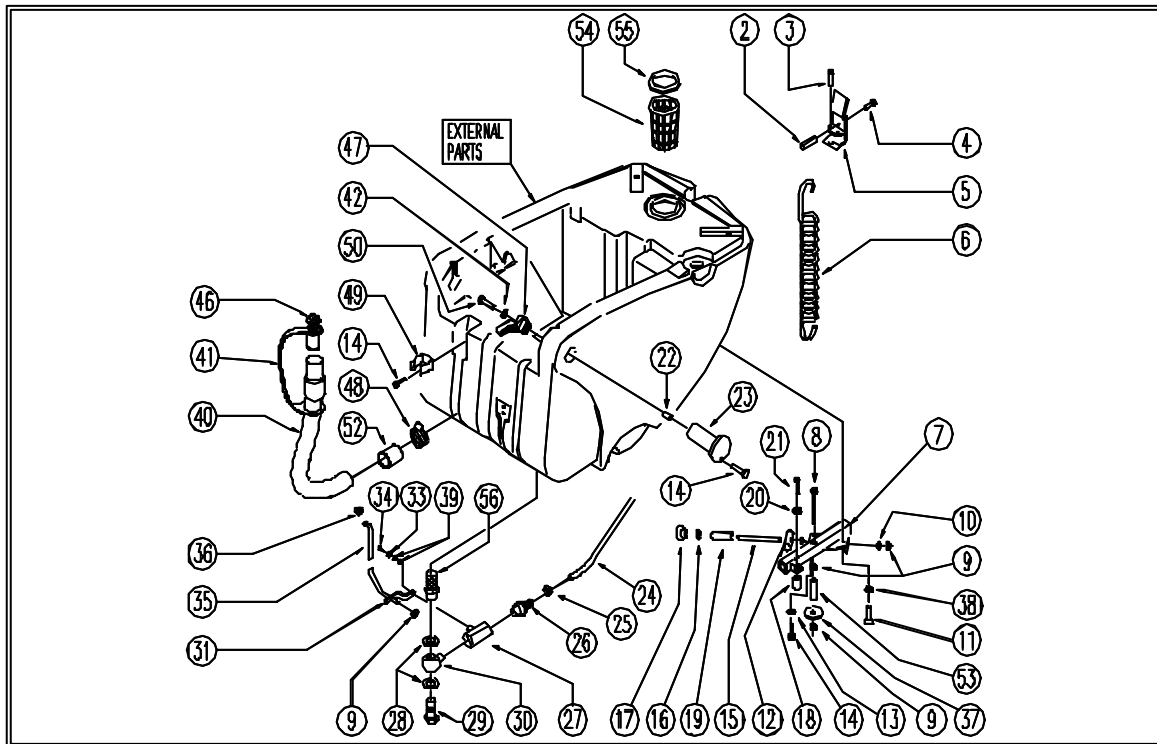

SK 20 AUTOMATIC SCRUBBER CODE: pl1004 ah SN from 01K430

REF.	CODE	DESCRIPTION	QTY
2	SL07425	SPACER	1
3	SL04222	SCREW	2
4	SL04278	SCREW	1
5	SL09829-4	HOOK	1
6	SL13102	SPRING	1
7	SL07368	SUPPORT	1
8	SL04140	SCREW	1
9	SL05041	NUT	3
10	SL06022	WASHER	2
11	SL04368	SCREW	1
12	SL07367	REGULATOR	1
13	SL06038	WASHER	1
14	SL04371	SCREW	5
15	SL04251	SHAFT	1
16	SL05048	NUT	1
17	SL20002	KNOB	1
18	SL07512	SPACER	1
19	SL07494	SPACER	1
20	SL06003	WASHER	1
21	SL04143	SCREW	1
22	SL04171	INSERT	2
23	SL17493-1	PIN	2

Next page →



← Back 1 page

SK 20 AUTOMATIC SCRUBBER CODE: pl1004 ah SN from 01K430			
REF.	CODE	DESCRIPTION	QTY
24	SL19326	HOSE	1
25	SL14109	CLAMP	1
26	SL18399	UNION / CONNECTOR	1
27	SL18407	TAP	1
28	SL03536	WASHER	2
29	SL18257-L	SCREW	1
30	SL18256	ARTICULATION	1
31	SL39171	LEVER	1
33	SL06031	WASHER	1
34	SL04341	SCREW	1
35	SL39091	ROD	1
36	SL11113	SEEGER	1
37	SL06069	WASHER	1
38	SL06032	WASHER	1
39	SL06041	WASHER	2
40	SL19113-1	HOSE	1
41	SL03577	CLAMP	1
42	SL06015	WASHER	3
46	SL18395	KNOB	1
47	SL17491-1	LEVER	1
48	SL14063	CLAMP	1
49	SL13118	DUCT LOCK	1
50	SL04135	SCREW	2
52	SL03546	SLEEVE	1
53	SL19330	HOSE	1
54	SL03526	FILTER	1
55	SL03543	GASKET	1
56	SL18405	FILTER	1



← Back 1 page

SK 20 AUTOMATIC SCRUBBER CODE: pl1005 af SN from 00C50

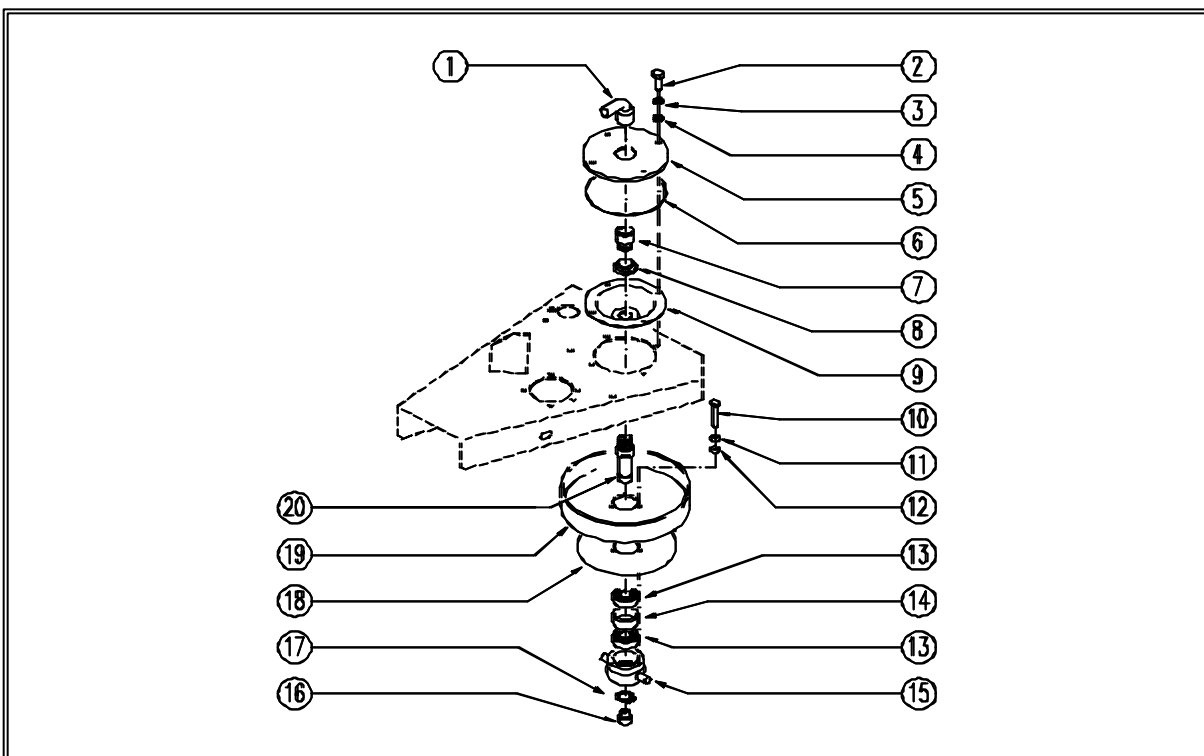

REF.	CODE	DESCRIPTION	QTY
1	SL18232	BEND	1
2	SL04134	SCREW	4
3	SL06057	WASHER	4
4	SL06041	WASHER	4
5	SL09944	COVER	1
6	SL03462	GASKET	1
7	SL18194	EXTENSION	1
8	SL05049	NUT	1
9	SL15023	FLANGE	1
10	SL04135	SCREW	3
11	SL06023	WASHER	3
12	SL06022	WASHER	3
13	SL12025	BEARING	2
14	SL07161	SPACER	1
15	SL01023	CONVEYOR, DRIVER	1
16	SL07492	CAP	1
17	SL11096	SEEGER	1
18	SL03511	DISC	1
19	SL10047	PULLEY	1
20	SL07303	PIN	1



SK 20 AUTOMATIC SCRUBBER CODE: pl1014 ai SN from 01J848

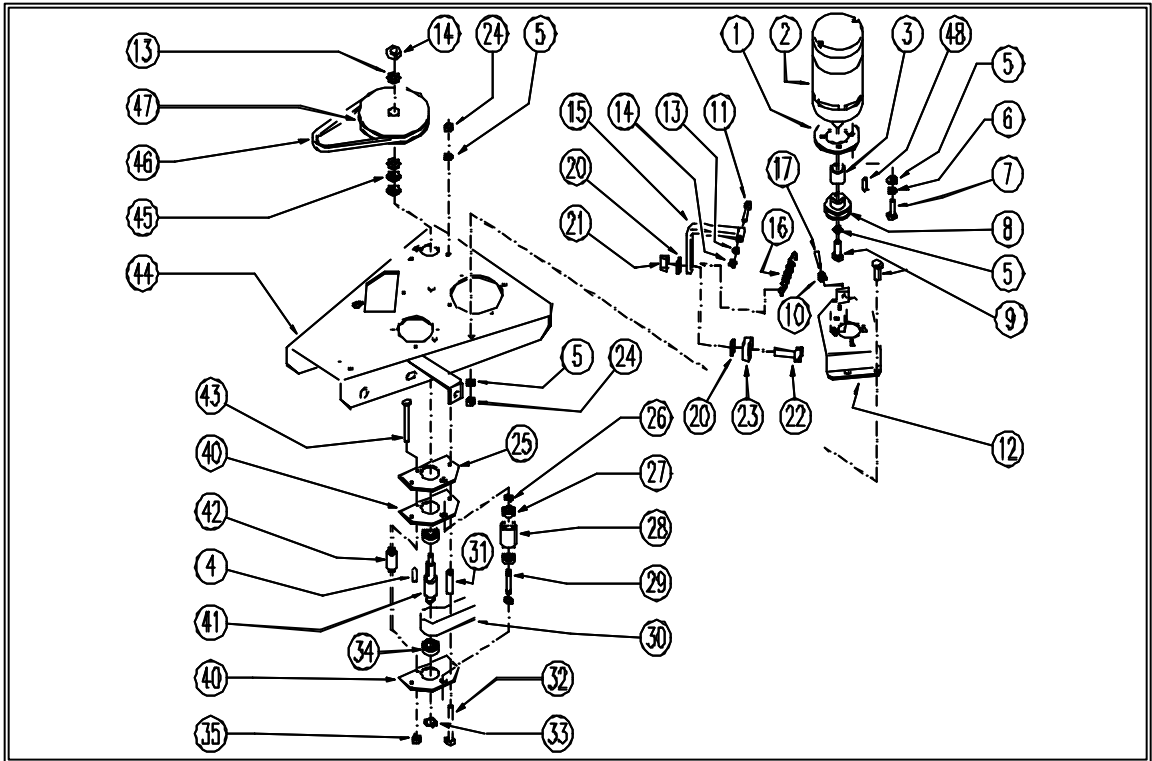

SK 20 AUTOMATIC SCRUBBER CODE: pl1014 ai SN from 01J848

REF.	CODE	DESCRIPTION	QTY
1	SL09648	FLANGE	1
2	GR02099	MOTOR	1
3	SL07418	SPACER	1
4	SL11010	TANG / TONGUE	1
5	SL06022	WASHER	10
6	SL06023	WASHER	4
7	SL04002	SCREW	2
8	SL10049	PULLEY	1
9	SL04135	SCREW	4
10	SL05004	NUT	1
11	SL04164	SCREW	1
12	SL39089	SUPPORT	1
13	SL06087	WASHER	2
14	SL05039	NUT	2
15	SL39088	ARM	1
16	SL13018	SPRING	1
17	SL11132	SCREW	1
20	SL06005	WASHER	2
21	SL05013	NUT	1
22	SL04005	SCREW	1
23	SL08046	WHEEL	1
24	SL05041	NUT	5
25	SL03438	GASKET	1
26	SL11095	SEEGER	2
27	SL12003	BEARING	2
28	SL10045	PULLEY	1



← Back 1 page

SK 20 AUTOMATIC SCRUBBER CODE: pl1014 ai SN from 01J848			
REF.	CODE	DESCRIPTION	QTY
29	SL11041	PIN / PLUG	1
30	SL16039	BELT	1
31	SL07143	SPACER	2
32	SL04058	SCREW	2
33	SL11100	SEEGER	1
34	SL12029	BEARING	2
35	SL05017	NUT	1
40	SL09592	PLAQUE	2
41	SL07190	SHAFT	1
42	SL07191	SPACER	1
43	SL04061	SCREW	1
44	SL39093	HEAD	1
45	SL06058	WASHER	3
46	SL16040	BELT	1
47	SL10048	PULLEY	1
48	SL11026	TANG / TONGUE	1



← Back 1 page

SK 20 AUTOMATIC SCRUBBER CODE: pl1015 ah SN from 011237

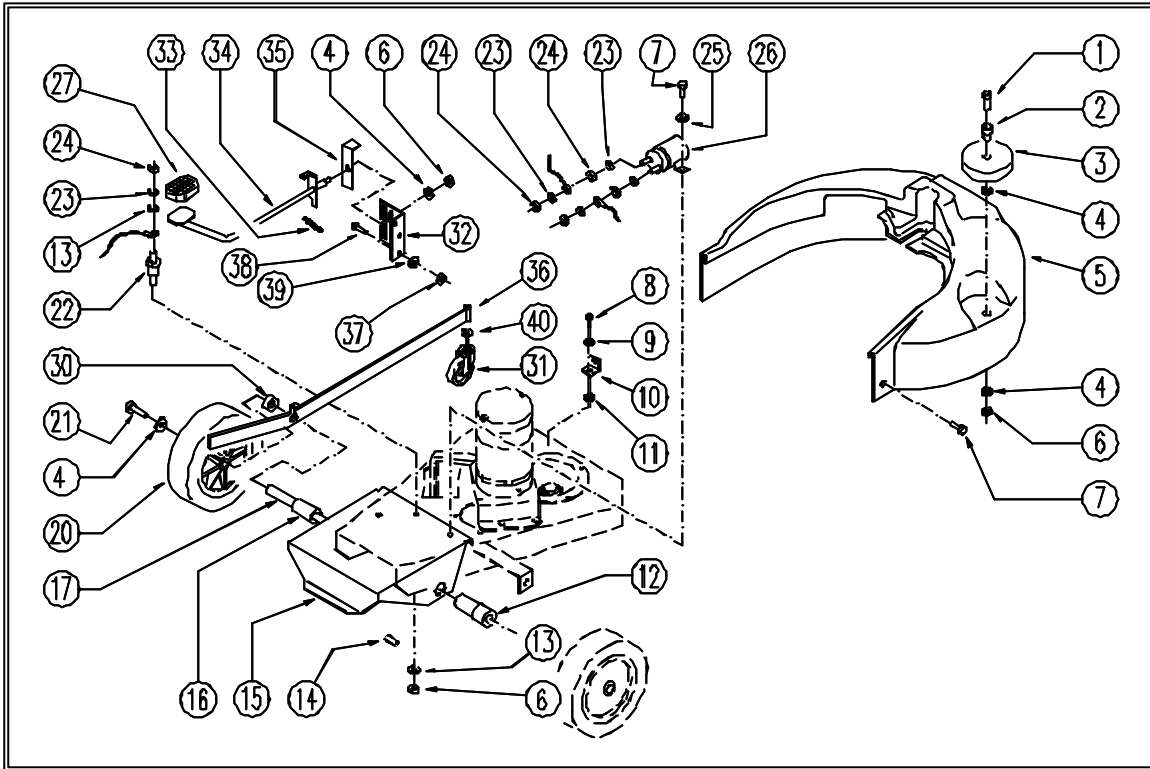

SK 20 AUTOMATIC SCRUBBER CODE: pl1015 ah SN from 011237

REF.	CODE	DESCRIPTION	QTY
1	SL04264	SCREW	2
2	SL07390	SPACER	1
3	SL08040	SMALL WHEEL	1
4	SL06025	WASHER	5
5	SL17562-1	BRUSH COVER	1
6	SL05039	NUT	3
7	SL04079	SCREW	4
8	SL04184	SCREW	2
9	SL06001	WASHER	1
10	SL09892	SMALL SQUARE	1
11	SL07150	BUSHING / BUSH	1
12	SL07379	BUSHING	1
13	SL06087	WASHER	2
14	SL11026	TANG	1
15	SL09895	BRACKET	1
16	SL07500	BUSHING	1
17	SL07505	SHAFT	1
20	SL08047	WHEEL	2
21	SL04077	SCREW	2
22	SL23103	SUPPORT	1
23	SL06002	WASHER	5

Next page →



← Back 1 page

SK 20 AUTOMATIC SCRUBBER CODE: pl1015 ah SN from 01I237

REF.	CODE	DESCRIPTION	QTY
24	SL05004	NUT	5
25	SL06019	WASHER	2
26	SL23001	REMOTE CONTROL SWITCH	1
27	SL20009	RUBBER SHIM	1
30	SL07498	SPACER	1
31	SL08029	SMALL WHEEL	1
32	SL39157	BRACKET	1
33	SL13095	SPRING	1
34	SL39156	ROD	1
35	SL39019	LEVER	1
36	SL39158	LEVER	1
37	SL05058	NUT	2
38	SL04135	SCREW	1
39	SL06022	WASHER	2
40	SL06005	WASHER	2



← Back 1 page

SK 20 AUTOMATIC SCRUBBER CODE: pl1008 ae SN from 01B600

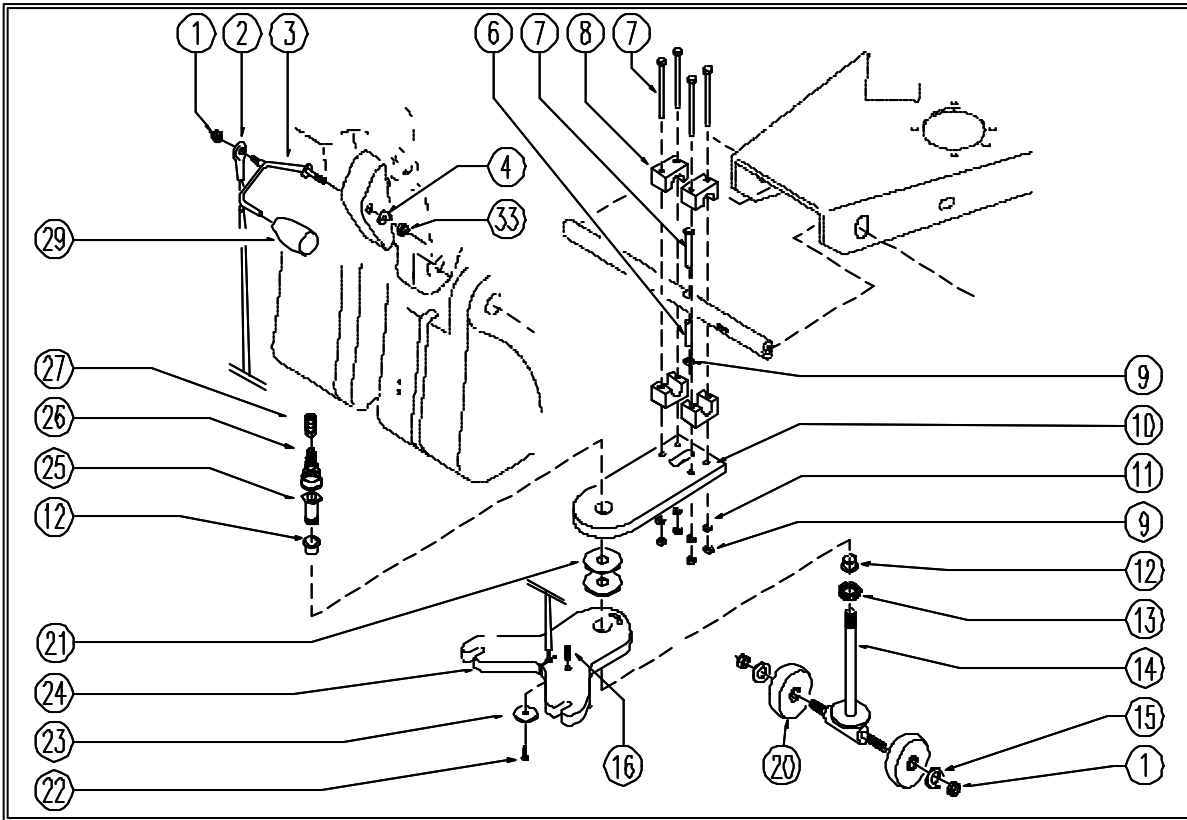

SK 20 AUTOMATIC SCRUBBER CODE: pl1008 ae SN from 01B600

REF.	CODE	DESCRIPTION	QTY
1	SL05039	NUT	3
2	SL14344	CABLE	1
3	SL39036	LEVER	1
4	SL06050	WASHER	2
6	SL07165	SPACER	1
7	SL04378	SCREW	5
8	SL12068	COLLAR	4
9	SL05058	NUT	5
10	SL39032	SUPPORT	1
11	SL06004	WASHER	4
12	SL12035	BEARING	2
13	SL05086	NUT	1
14	SL07507	PIN	1
15	SL06041	WASHER	2
16	SL11126	GRAIN	1
20	SL08043	WHEEL / SMALL WHEEL	2
21	SL06106	WASHER	2
22	SL04319	SCREW	1
23	SL06084	WASHER	1
24	SL39031	PLATE	1

Next page →



← Back 1 page

SK 20 AUTOMATIC SCRUBBER CODE: pl1008 ae SN from 01B600			
REF.	CODE	DESCRIPTION	QTY
25	SL07509	PIN	1
26	SL13126	SPRING	1
27	SL07508	NUT	1
29	SL20007	HANDGRIP	1
33	SL05032	NUT	1



← Back 1 page

SK 20 AUTOMATIC SCRUBBER CODE: pl1010 ae SN from 01J899

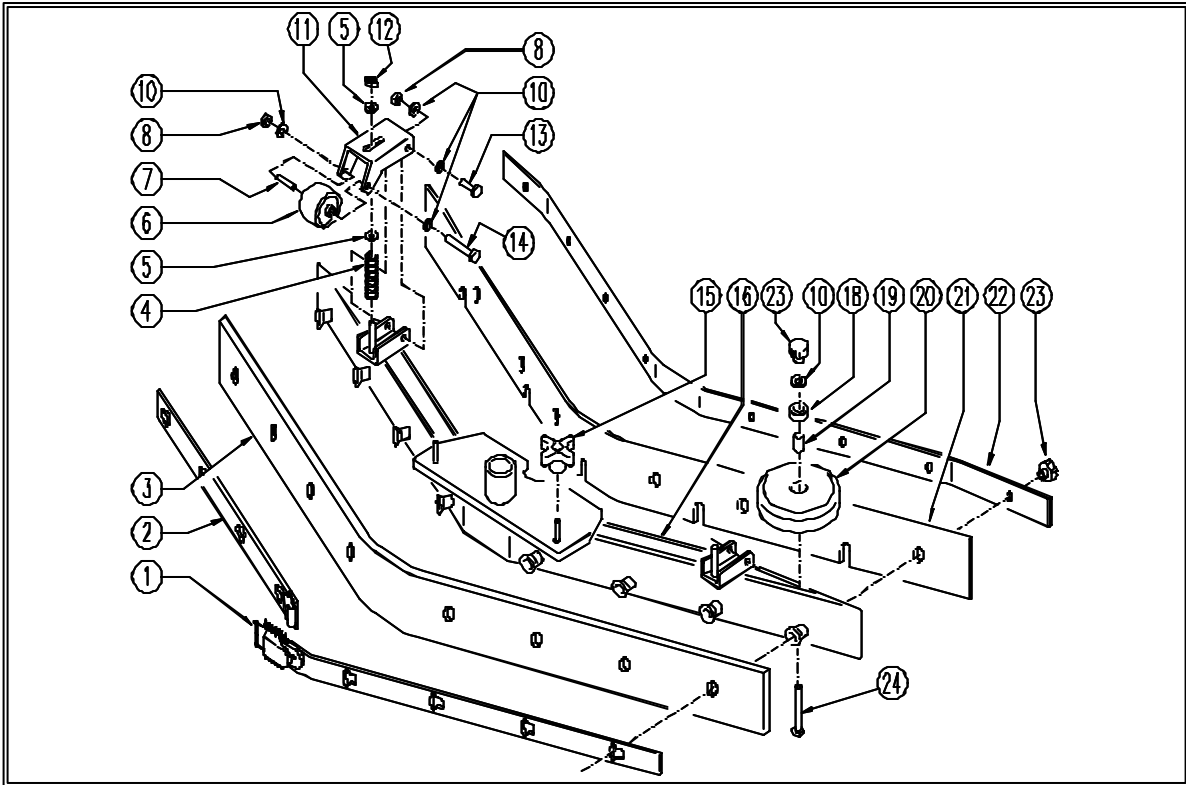

SK 20 AUTOMATIC SCRUBBER CODE: pl1010 ae SN from 01J899

REF	CODE	DESCRIPTION	QTY
	GR39027	SQUEEGEE UNIT	
1	SL39029	BLADE HOLDER	1
2	SL39030	BLADE HOLDER	1
3	SL03518	BLADE	1
4	SL13103	SPRING	2
5	SL06041	WASHER	4
6	SL08058	WHEEL	2
7	SL07526	SPACER	2
8	SL05058	NUT	6
10	SL06022	WASHER	14
11	SL39033	SUPPORT	2
12	SL05039	NUT	2
13	SL04135	SCREW	4
14	SL04061	SCREW	2
15	SL20061	HANDLE	2
16	SL39136	BODY	1
18	SL17608	BUSHING/BUSH	2
19	SL07065	SPACER	2
20	SL08040	WHEEL	2

Next page →



← Back 1 page

SK 20 AUTOMATIC SCRUBBER CODE: pl1010 ae SN from 01J899			
REF	CODE	DESCRIPTION	QTY
21	SL03517	BLADE	1
22	SL39028	BLADE HOLDER	1
23	SL20058	HANDLE	10
24	SL04058	SCREW	2



← Back 1 page

SK 20 AUTOMATIC SCRUBBER CODE: pl1016 ae SN from 01B600

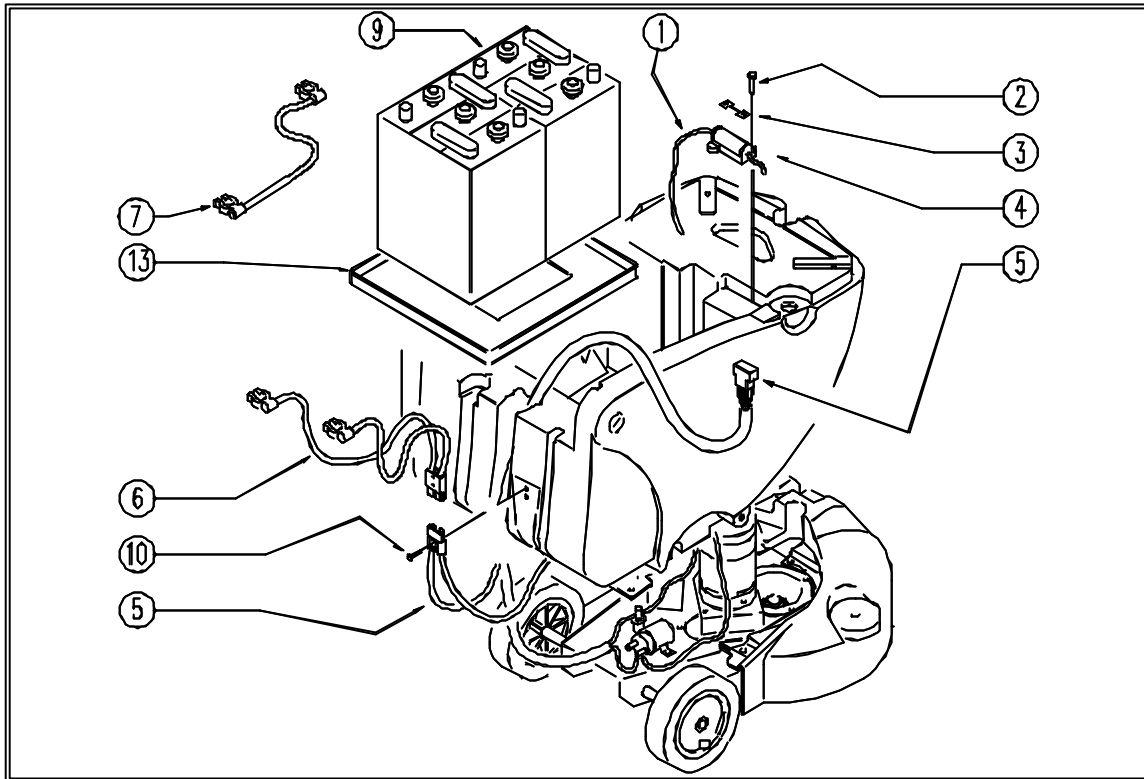

SK 20 AUTOMATIC SCRUBBER CODE: pl1016 ae SN from 01B600

REF.	CODE	DESCRIPTION	QTY
1	SL23630	WIRING	1
2	SL04303	SCREW	2
3	SL23696	FUSE	1
4	SL23697	FUSE CARRIER	1
5	SL23629	WIRING	1
6	SL23628	WIRING	1
7	SL23838	JUMPER	1
9	AL03122	BATTERY	2
10	SL04016	SCREW	2
13	SL17162-1	PLATE	1



← Back 1 page

SK 20 AUTOMATIC SCRUBBER CODE: pl1043N ad SN from 02A000

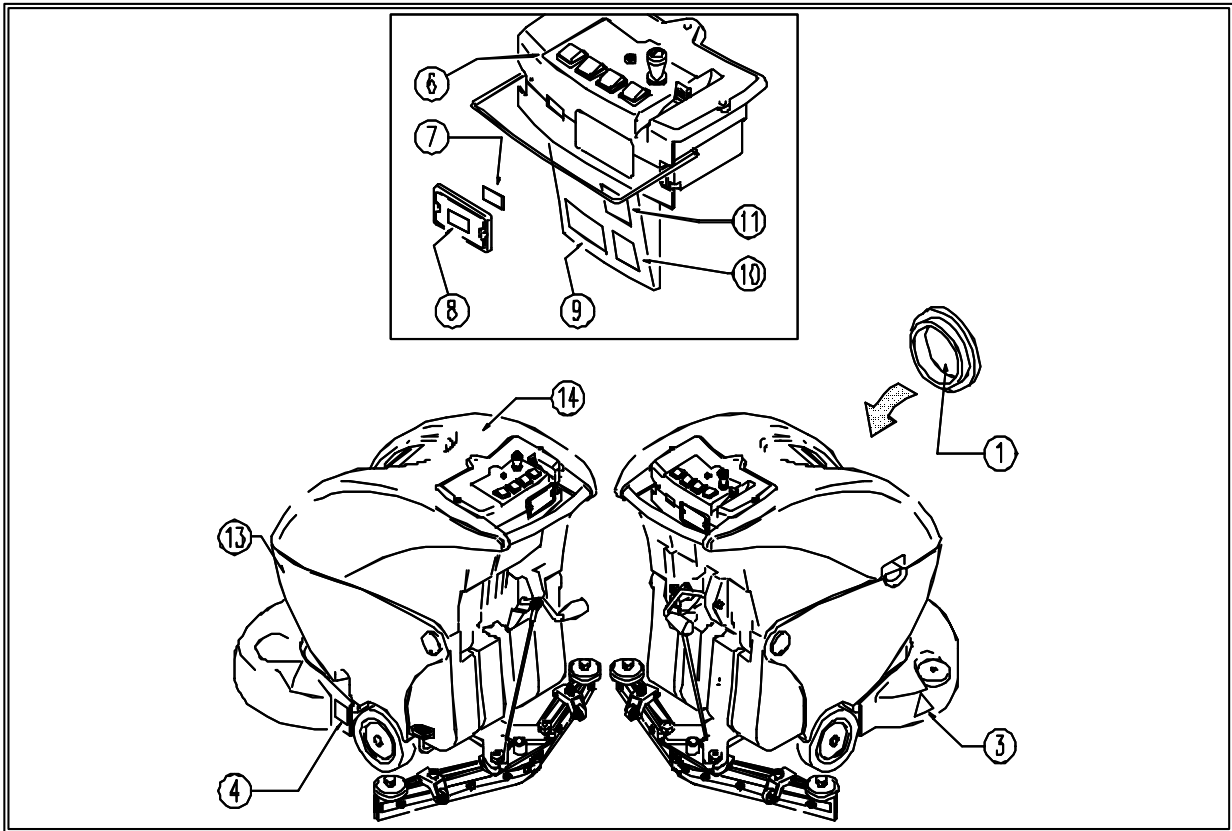

SK 20 AUTOMATIC SCRUBBER CODE: pl1043N ad SN from 02A000

REF.	CODE	DESCRIPTION	QTY
1	SL25056	LABEL	1
3	SL25472	LABEL	1
4	SL25743	LABEL	1
6	SL25960	LABEL	1
7	SL25928	LABEL	1
8	SL25187	LABEL	1
9	SL25002	LABEL	1
10	SL25177	LABEL	1
11	SL25053	LABEL	1
13	SL17594	BLACK TANK	1
13	SL17594GR	GREY TANK	1
13	SL17594IC	BLUE TANK	1
14	SL17595AS	GREY TANK	1
14	SL17595BC	RED TANK	1
14	SL17595IC	BLUE TANK	1



← Back 1 page

SK 20 AUTOMATIC SCRUBBER CODE: p11278 ab SN from 99C100

POLYPROPYLENE- NYLON - NYLON
NYLON - NYLON

①

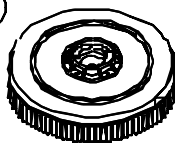

POLYSHING - POLIERBURSTERN
SORGHO - FIBRA - BASSINA

②

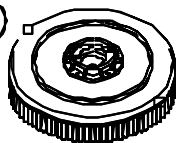

TYNEX - TYNEX - TYNEX
TYNEX - TYNEX

③

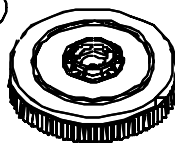

④

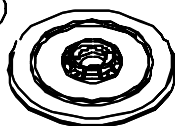

BLACK - SCHWARZ - NOIR
PAD - NERO

⑤

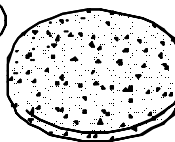

GREEN - GRUEN- VERT
VERDE - VERDE

⑥

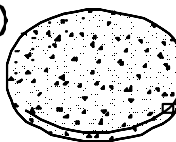

YELLOW - GELB - JEUNE
AMARILLO - GIALLO

⑦

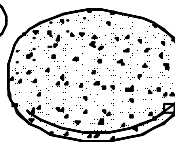

SK 20 AUTOMATIC SCRUBBER CODE: p11278 ab SN from 99C100

REF.	CODE	DESCRIPTION	QTY
1	AL02251	POLYPROPYLENE BRUSH	
2	AL02253	POLYSHING BRUSH	
3	AL02252	TYNEX BRUSHES	
4	AL02217-2	PAD DRIVER	
5	00020028	STRIPPING PAD(BLACK)	
6	00020029	STRIPPING PAD(GREEN)	
7	00020030	STRIPPING PAD(YELLOW)	



← Back 1 page

SK 20 AUTOMATIC SCRUBBER CODE: pl1074N ac SN from 01B600

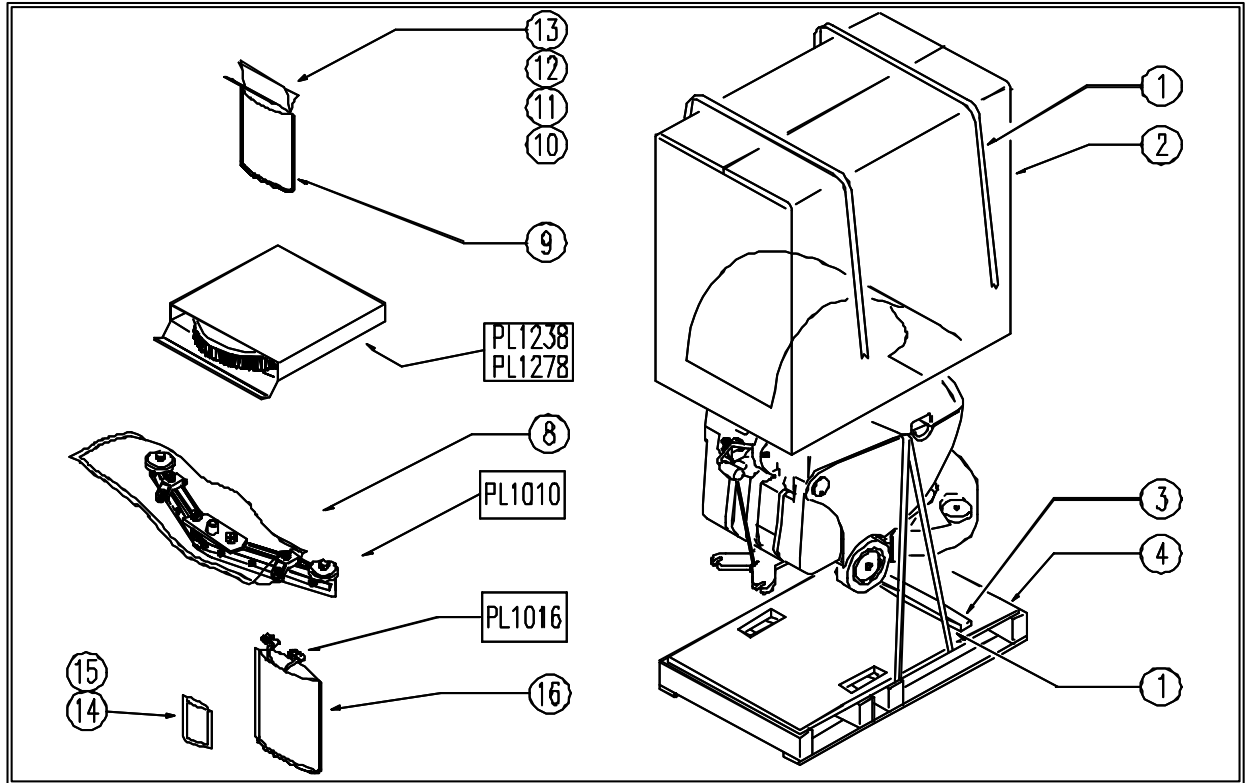

SK 20 AUTOMATIC SCRUBBER CODE: pl1074N ac SN from 01B600

REF.	CODE	DESCRIPTION	QTY
1	MP14300	STRAP	/
2	SL26133	CARDBOARD	1
3	SL26011	REINFORCEMENT	1
4	SL26132	PALLET	1
8	MP14302	ENVELOPE	1
9	SL26029	ENVELOPE	1
10	SL25303N	SHEET	1
11	SL25401-3	WARRANTY COUPON	1
12	SL25401-8	EC CERTIFICATION	1
13	SL25952N-4	MANUAL	1
14	SL26029	ENVELOPE	1
15	SL23010K	CONNECTOR	1
16	SL26017	ENVELOPE	1



SK 20 AUTOMATIC SCRUBBER CODE: wd27190 ac SN from 01B600

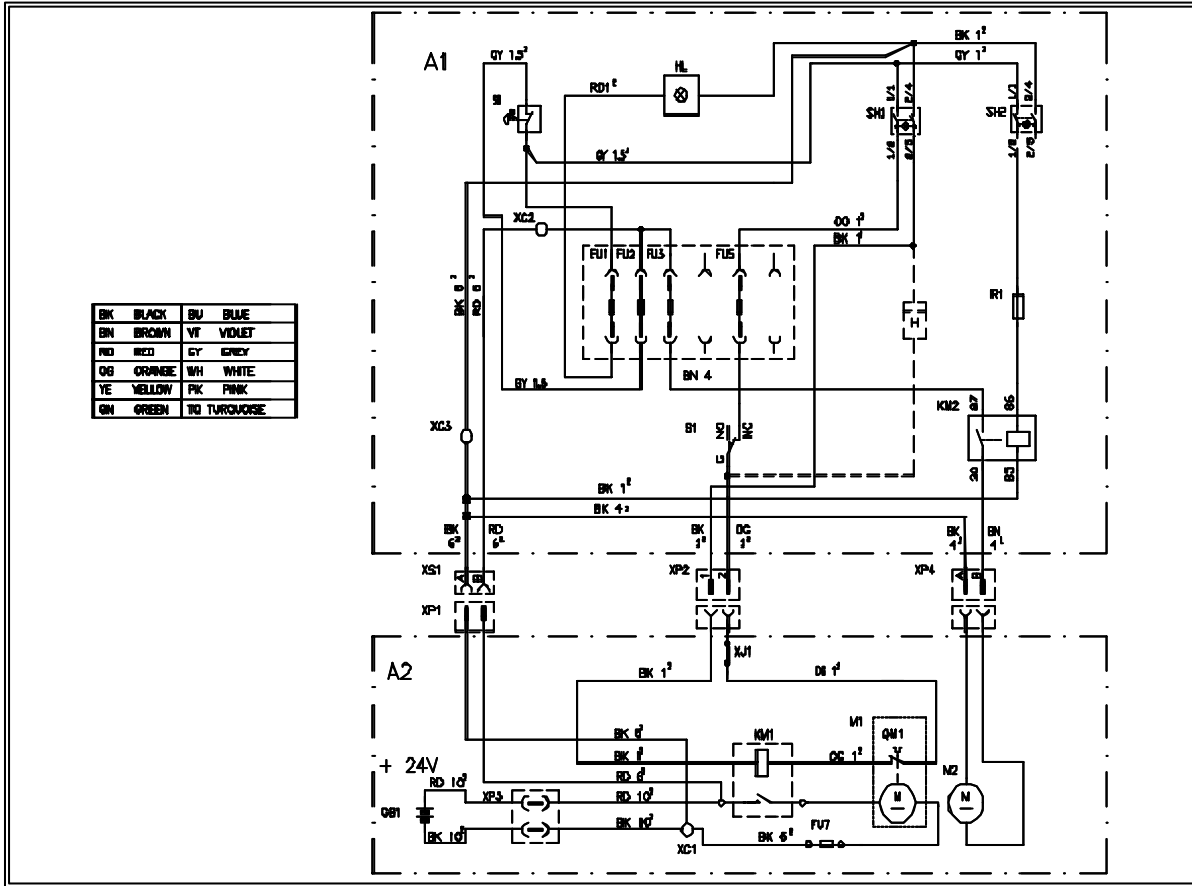

BK	BLACK	BU	BLUE
BN	BROWN	VI	VIOLET
RD	RED	GY	GREY
OG	ORANGE	WH	WHITE
YE	YELLOW	PK	PINK
GN	GREEN	TD	TURNOVERSE

SK 20 AUTOMATIC SCRUBBER CODE: wd27190 ac SN from 01B600

REF.	CODE	DESCRIPTION	QTY
FU1	SL23144	FUSE	
FU2	SL23148	FUSE	
FU3	SL23148	FUSE	
FU5	SL23144	FUSE	
FU7	SL23696	FUSE	
HL	SL23031	INDICATOR	
KM1	SL23001	REMOTE CONTROL SWITCH	
KM2	SL23719	RELAY	
M1	SL02099	BRUSH MOTOR	
M2	SL02303-J	SUCTION MOTOR	
QM1		GUARD	
R1	SL23734	RESISTANCE	
S1	SL23109	MICROSWITCH	
SB	SL23954	EMERGENCY BUTTON	
SH1	SL23183	SWITCH	
SH2	SL23183	SWITCH	
XC1	SL23103	INSULATOR	
XC2	SL23428	CLAMP	



← Back 1 page

SK 20 AUTOMATIC SCRUBBER CODE: wd27190 ac SN from 01B600			
REF.	CODE	DESCRIPTION	QTY
XC3	SL23414	CLAMP	
XP1	SL23562	CONNECTOR	
XP2	SL23550	CONNECTOR	
XP3	SL23010K	CONNECTOR	
XP4	SL23562	CONNECTOR	
XS1	SL23564	CONNECTOR	
XS2	SL23551	CONNECTOR	
XS4	SL23564	CONNECTOR	
XJ1	SL23247	ELECTRIC CONNECTION	
H	AL03313	HOUR METER (OPTIONAL)	
A1		CONTROL PANEL	
A2		BODY WIRING DIAGRAM	



SK 20 AUTOMATIC SCRUBBER CODE: wd27190-1 ac SN from 01B600

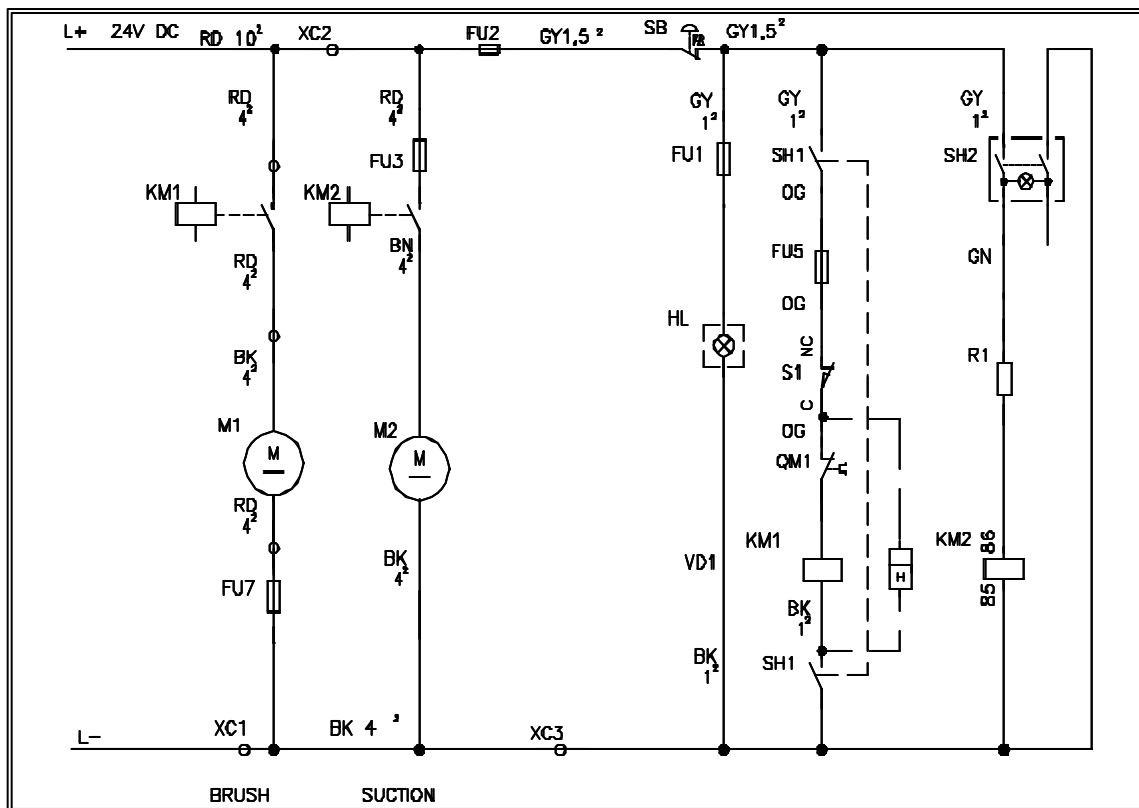

SK 20 AUTOMATIC SCRUBBER CODE: wd27190-1 ac SN from 01B600

REF.	CODE	DESCRIPTION	QTY
FU1	SL23144	FUSE	
FU2	SL23148	FUSE	
FU3	SL23148	FUSE	
FU5	SL23144	FUSE	
FU7	SL23696	FUSE	
GB1		BATTERY	
HL	SL23031	INDICATOR	
KM1	SL23001	REMOTE CONTROL SWITCH	
KM2	SL23719	RELAIS	
M1	SL02099	BRUSH MOTOR	
M2	SL2303-J	SUCTION MOTOR	
QM1		GUARD	
R1	SL23734	RESISTANCE	
S1	SL23109	MICROSWITCH	
SB	SL23954	EMERGENCY BUTTON	
SH1	SL23183	SWITCH	
SH2	SL23183	SWITCH	
XC1	SL23103	INSULATOR	
XC2	SL23414	CLAMP	
XC3	SL23428	CLAMP	
H	AL03313	HOUR METER (OPTIONAL)	



Eagle Power™ Products Group

Warranty Policy

Limited Warranty

Eagle Power Products (EPP) warrants new cleaning equipment against defects in material and workmanship under normal use and service to the original purchaser as detailed below.

10 Years

Subject to the conditions stated below, EPP warrants polyethylene tanks and housings to be free from defects in materials and workmanship for a period of ten years.

3 Years

Subject to the conditions stated below, EPP warrants all automatic scrubber components to be free from defects in materials and workmanship for a 3-year period. Parts replaced or repaired are warranted for the remainder of the original warranty period.

1 Year

Subject to the conditions stated below, EPP warrants all other cleaning equipment components to be free from defects in materials and workmanship for a 1-year period. Parts replaced or repaired are warranted for the remainder of the original warranty period. Batteries are prorated for one year.

EPP will furnish and charge for replacement parts, including transportation, to the original owner through an EPP authorized service center. If the part is returned within 30 days and is found defective, the owner will be credited for the cost of the replacement part including shipping and handling.

Labor charges are covered for one year from the date of purchase if provided by an authorized EPP service center. Travel is covered for 90 days for battery operated equipment only.

Wear items exempt from warranty include belts, carbon brushes, power cords, wheels, pad drivers, clutch plates, brushes, pads, handle grips, filters, screens, throttle cables, and squeegees.

This warranty shall not apply to failures caused by misuse or abuse, improper maintenance as stated in the operation manuals, use of unauthorized repair parts, repairs by other than an EPP authorized service center, and damage in transit.

EPP disclaims and denies any liability for any direct, indirect, special incidental or consequential damage which may be suffered as a result of sale, delivery, servicing, use, loss of any product, downtime, labor, freight, or other charges not expressly included herein.

Date Purchased: _____

Serial Number: _____

Serial Number: _____

Please be sure to record this information. This information will be necessary for future warranty claims.



1174 Northland Drive Mendota Heights, MN 55120
651.686.5399 Fax 651.686.5695
www.eaglepower.com

Eagle Power Products Sales and Service Provided by: