

ScrubMaster 26B

Parts List

The contents of this manual are based on the latest product information available at the time of publication. Pacific Steamex reserves the right to make changes or improvements to its machines without notice.

For new books write to:

Pacific Steamex, Inc.
2259 S. Sheridan
Muskegon, MI 49442-6252

FOR YOUR CONVENIENCE, RECORD THE FOLLOWING INFORMATION:

MODEL _____

SERIAL NUMBER _____

PART NUMBER _____

DATE PURCHASED _____

BRUSH BASE ASSEMBLY

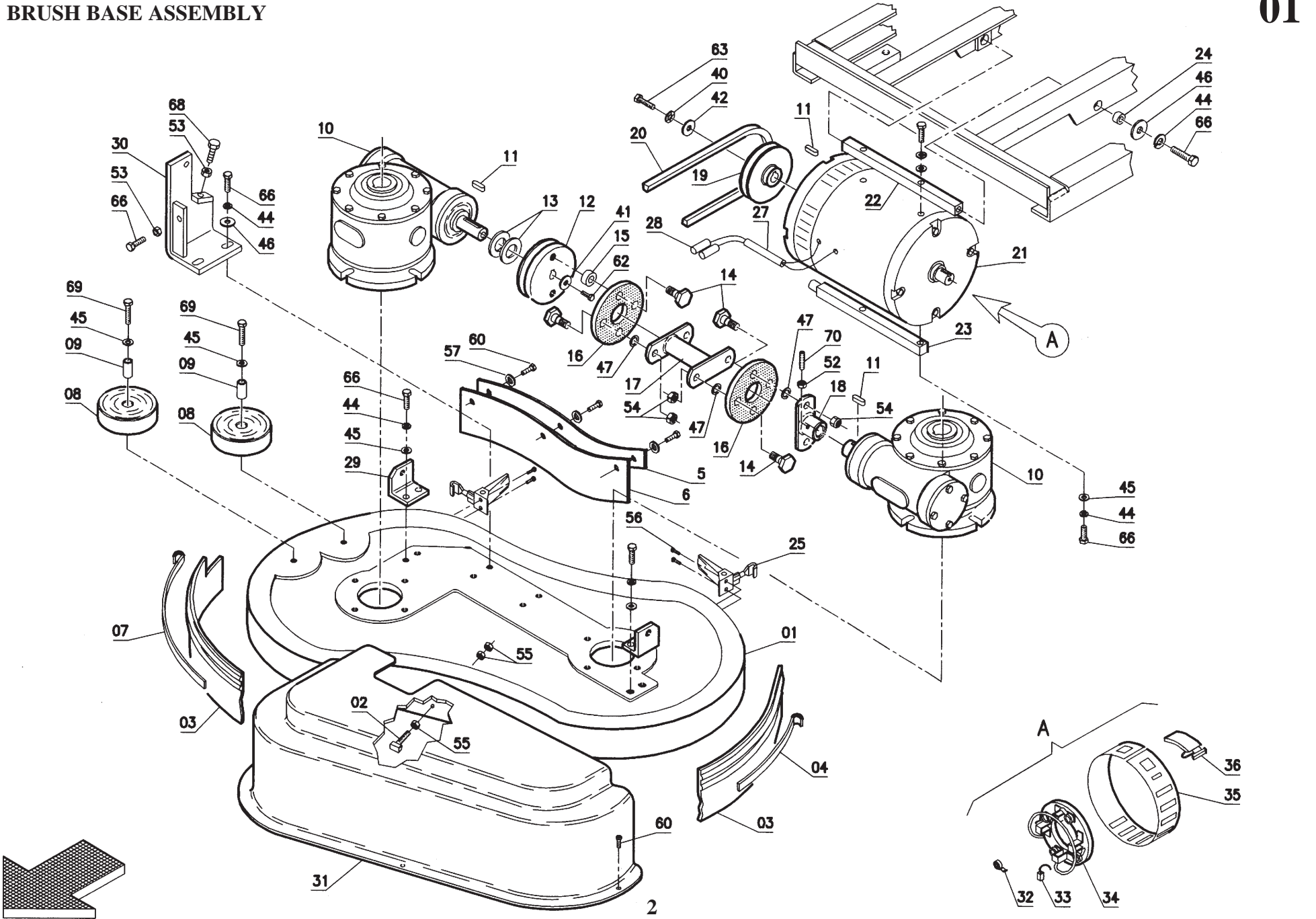

26B - DRAWING 01

Item	Part Number	Description	Qty.
1	69807020	Brushes Base	1
2	40301120	Special Screw	1
3	67607040	Splash Guard	1
4	40701180	Blade	1
5	40701200	Blade	1
6	67607050	Splash Guard	1
7	40701070	Blade	1
8	67020030	Wheel	2
9	69102110	Bushing	2
10	68600010	Reduction Gear Assembly	2
11	70405052	Key	3
12	69410040	Pulley	1
13	69006050	Spacer	2
14	40701140	Stud Bolt	8
15	69006010	Spacer	2
16	40701110	Flexible Coupling	2
17	40701120	Shaft	1
18	40701130	Reduction Gear Hub	1
19	69410210	Motor Pulley	2
20	70110002	Belt	1
21	68230900	Motor	1
22	40704030	Motor Support	1
23	40704020	Support	1
24	69102050	Bushing	2
25	74400002	Hook, Assembly	1
27	67404070	Sheath	1
28	67404210	Pipe	2
29	40701010	Support	2

Item	Part Number	Description	Qty.
30	40703250	Support	1
31	40746170	Base Cover	1
32	72901001	Spring	4
33	71710181	Brush	4
34	72901015	Ring	1
35	73501103	Clamp	1
36	73501106	Hook	1
40	71306001	Lock Washer	
41	71106005	Washer: 6x18	
42	71106007	Washer: 6x24	
44	71108009	Lock Washer: 8x3	
45	71108003	Washer: 8x17	
46	71108007	Washer: 9x24	
47	71110002	Washer: 10x21	
52	71020601	Nut: M6	
53	71010801	Nut: M8	
54	71021002	Lock Nut: M10	
55	71010502	Nut: M5	
56	70910412	Screw	
57	71105002	Washer	
60	70940502	Screw	
62	70910607	Screw	
63	70910609	Screw	
66	70910808	Screw	
68	70910810	Screw	
69	70910812	Screw	
70	70960602	Dowel	

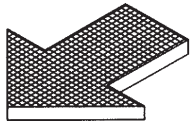
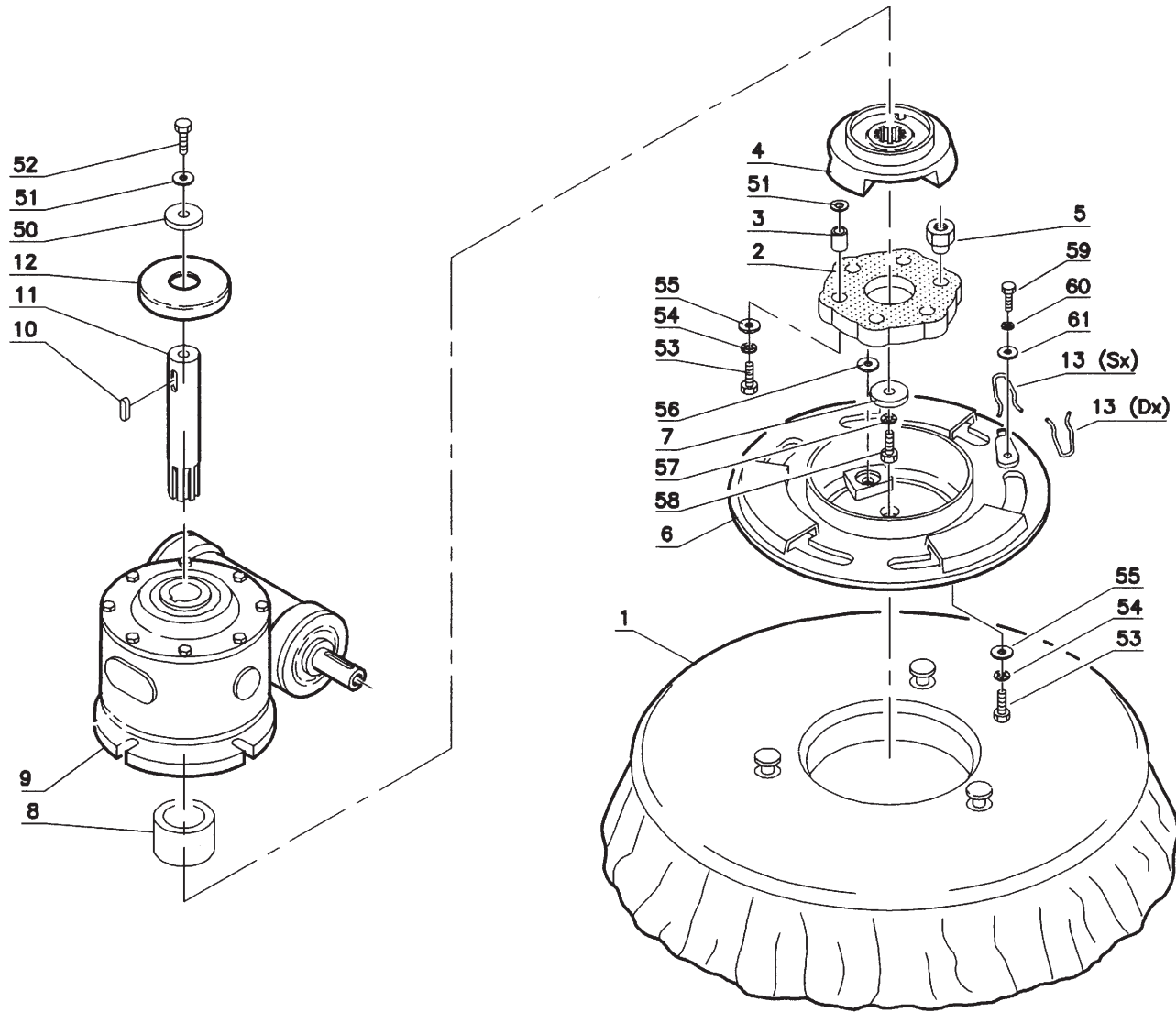

26B - DRAWING 02

Item	Part Number	Description	Qty.
1	880970	Brush	2
2	40301070	Flexible Coupling	2
3	69009040	Spacer	6
4	41201040	Flange	2
5	69109040	Bushing	6
6	41201050	Brush Plate	2
7	40205080	Special Washer	2
8	69006060	Spacer	2
9	68600010	Reduction Gear Assembly	2
10	70408071	Key	2
11	40701160	Shaft	2
12	40301160	Cap	2
13	69230010	Spring	2
50	71108007	Washer	
51	71108009	Lock Washer	
52	70910804	Screw	
53	70910810	Screw	
54	71308001	Lock Washer	
55	71108007	Washer	
56	71308004	Washer	
57	71108009	Lock Washer	
58	70930801	Screw	
59	70910602	Screw	
60	71306001	Lock Washer	
61	71106007	Washer	

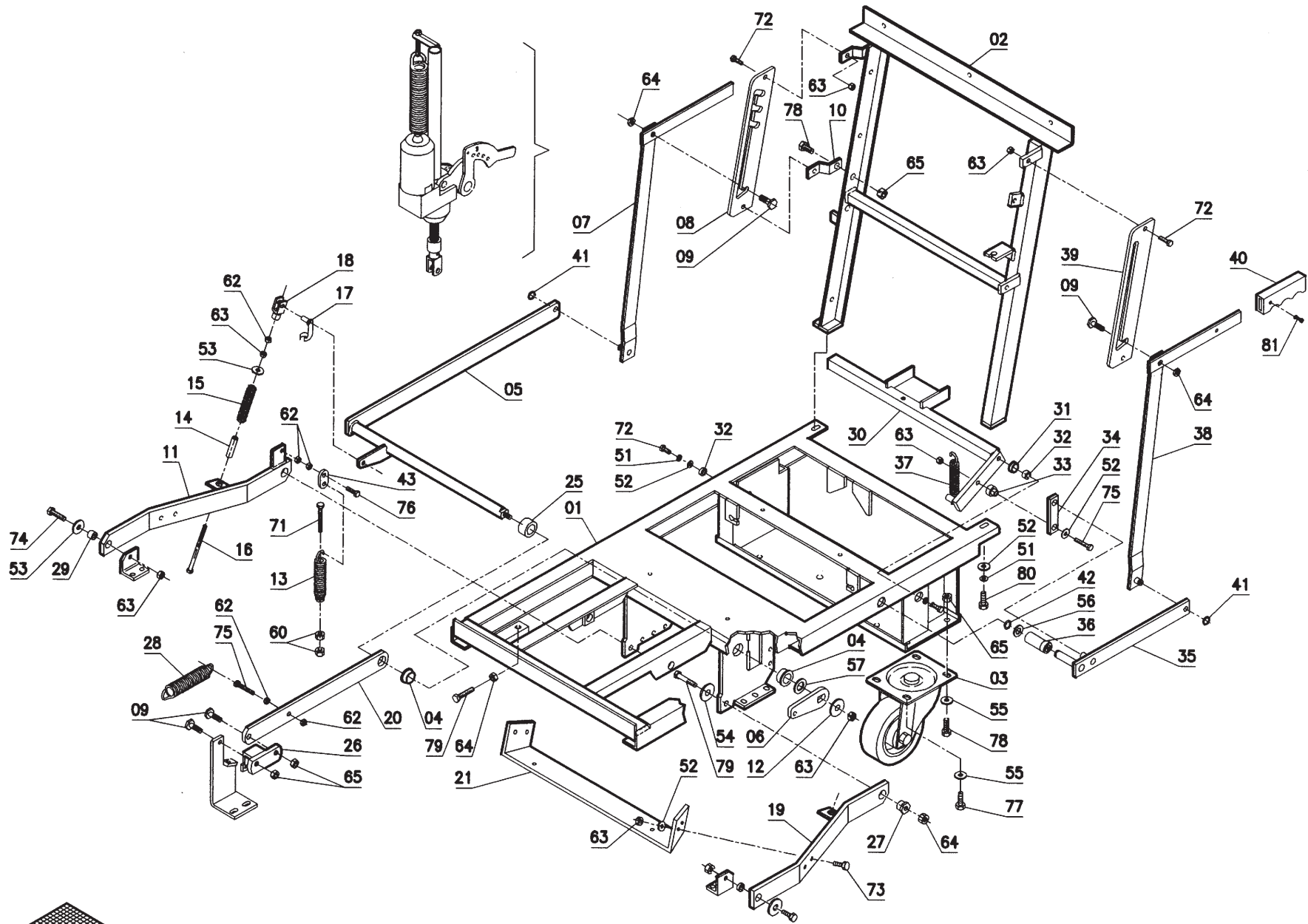

26B - DRAWING 03

Item	Part Number	Description	Qty.
1	69907100	Frame	1
2	69907200	Rear Frame	1
3	67050060	Castor Wheel	2
4	69102040	Bushing	2
5	40703220	Shaft	1
6	40303300	Lever	1
7	40303260	Lever	1
8	40303270	Toothed Blade	1
9	40312270	Pin	4
10	40703260	Plaque	1
11	40703230	Right Arm	1
12	40205080	Special Washer	1
13	69220190	Spring	1
14	40303040	Pipe	2
15	69210200	Spring	2
16	40303030	Special Screw	2
17	74620001	Pin	2
18	74610001	Fork	2
19	40703240	Left Arm	1
20	40703370	Arm	1
21	40703270	Bar	1
25	69002030	Spacer	1
26	40703380	Joint	1
27	69106010	Bushing	2
28	69220150	Spring	1
29	69102070	Bushing	2
30	40712020	Shaft	1
31	69102270	Bushing	1
32	69102050	Bushing	2
33	69102260	Bushing	1
34	40312280	Rod	1
35	40312240	Lever	1

Item	Part Number	Description	Qty.
36	69102250	Bushing	1
37	69220160	Spring	1
38	40312250	Lever	1
39	40312260	Toothed Blade	1
40	74100007	Knob	2
41	70230008	Seeger Ring	2
42	70230006	Seeger Ring	1
43	40703030	Coupling	1
51	71108009	Lock Washer	
52	71108003	Washer: 8x17	
53	71108007	Washer: 9x24	
54	71110007	Lock Washer: 10x2, 5	
55	71110002	Washer: 10x21	
56	71114002	Washer: 15x28	
57	71121001	Washer: 21x37	
60	71010601	Nut: M6	
62	71010801	Nut: M8	
63	71020801	Lock Nut: M8	
64	71011002	Nut: M10	
65	71021002	Lock Nut: M10	
71	70910623	Screw: M6x60	
72	70910806	Screw: M8x22	
73	70910808	Screw	
74	70910810	Screw: M8x30	
75	70910812	Screw: M8x35	
76	70910815	Screw: M8x45	
77	70911001	Screw: M10x12	
78	70911004	Screw: M10x22	
79	70911025	Screw: M10x55	
80	70910804	Screw: M8x20	
81	70940502	Screw: M5x10	

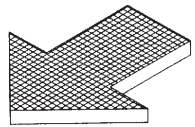
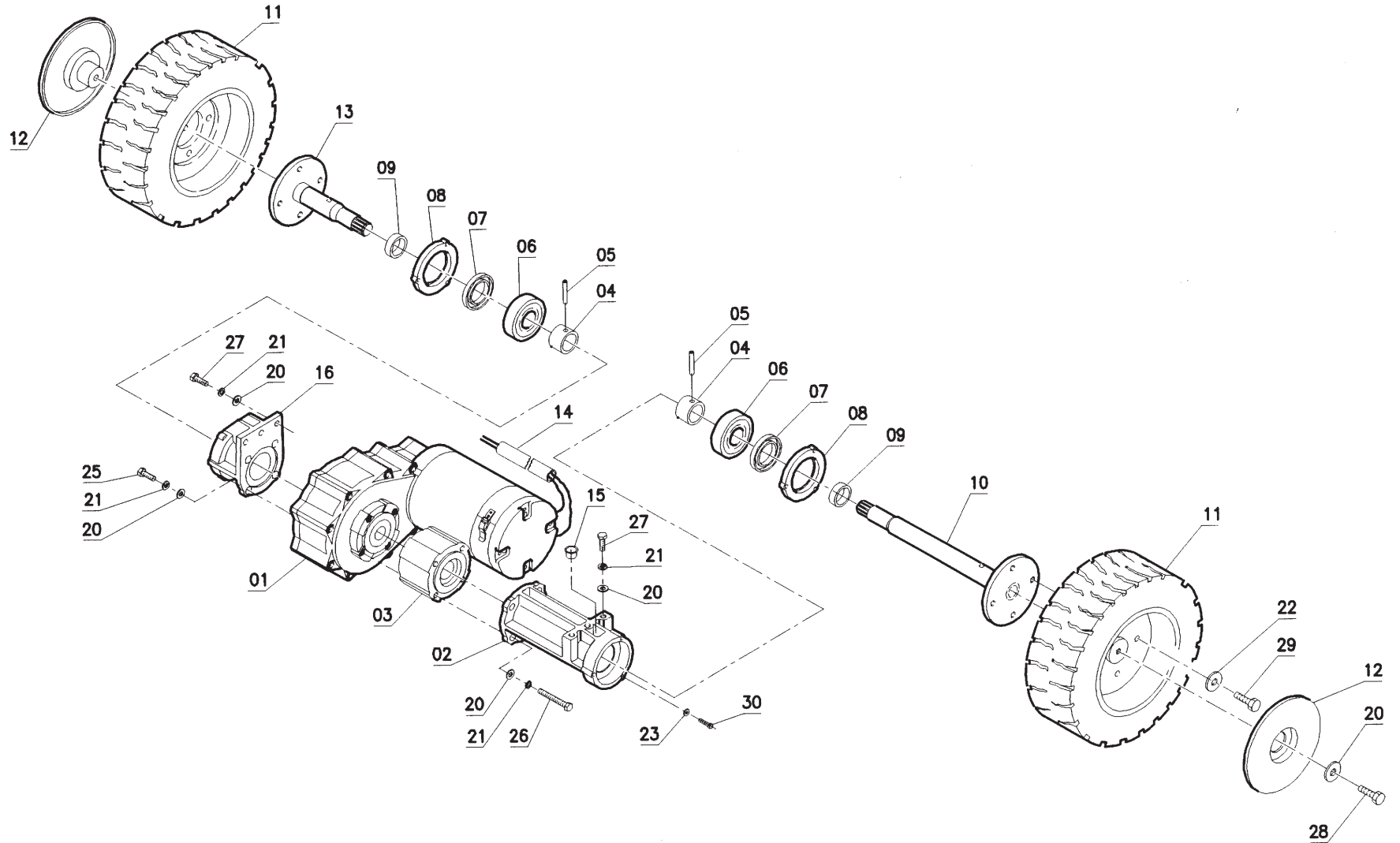

26B - DRAWING 04

Item	Part Number	Description	Qty.
1	68200320	Geared Motor	1
2	40730030	Support	1
3	73501201	Spacer	1
4	69006040	Spacer	2
5	71406003	Spring Pin	2
6	70512503	Bearing	2
7	70732521	Oil Seal	2
8	40730040	Cover	2
9	69006030	Spacer	2
10	68907030	Left Axle Shaft	1
11	67030550	Rubber Wheel	2
12	41617020	Wheel Cover	2
13	68907020	Right Axle Shaft	1
14	67404160	Sheath	1
15	72913015	Cap	4
16	40730020	Support	1
20	71108003	Washer: 8x17	
21	71108009	Lock Washer: 8x3	
22	71110002	Washer: 10x21	
23	71305001	Lock Washer	
25	70910808	Screw: M8x25	
26	70910827	Screw: M8x50	
27	70910806	Screw: M8x22	
28	70910803	Screw: M8x16	
29	70911004	Screw: M10x22	
30	70910503	Screw: M5x16	

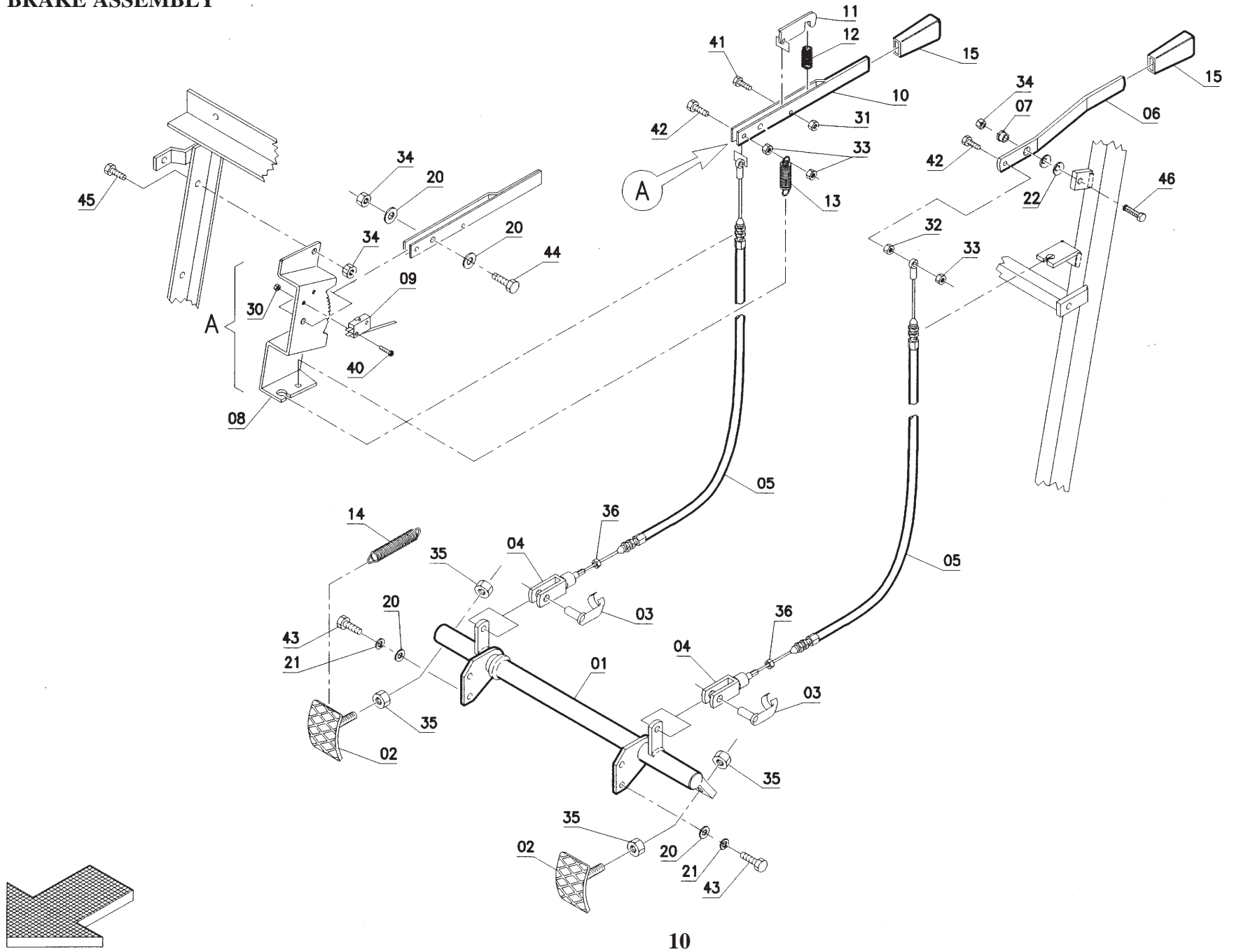

26B - DRAWING 05

Item	Part Number	Description	Qty.
1	40718050	Shaft	1
2	41618040	Pad	2
3	74620006	Pin	2
4	74610005	Fork	2
5	74803042	Brake Cable	2
6	40318090	Lever	1
7	69111010	Bushing	1
8	40318080	Support	1
9	72105009	Microswitch	1
10	40318100	Lever	1
11	40318110	Lever	1
12	69210540	Spring	1
13	69220440	Spring	1
14	69220150	Spring	1
15	74100005	Knob	2
20	71108003	Washer: 8x17	
21	71108009	Lock Washer: 8x3	
22	71120003	Washer: 12x25	
30	71020301	Lock Nut: M3	
31	71020401	Lock Nut: M4	
32	71010601	Nut: M6	
33	71020601	Lock Nut: M6	
34	71020801	Lock Nut: M8	
35	71011202	Nut: M12	
36	71010801	Nut: M8	
40	70940303	Screw: M3x20	
41	70910407	Screw: M4x16	
42	70910613	Screw: M6x25	
43	70910804	Screw: M8x20	
44	70910806	Screw: M8X22	
45	70910808	Screw: M8x25	
46	70910810	Screw: M8x30	

SQUEEGEE FRAME ASSEMBLY

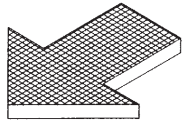
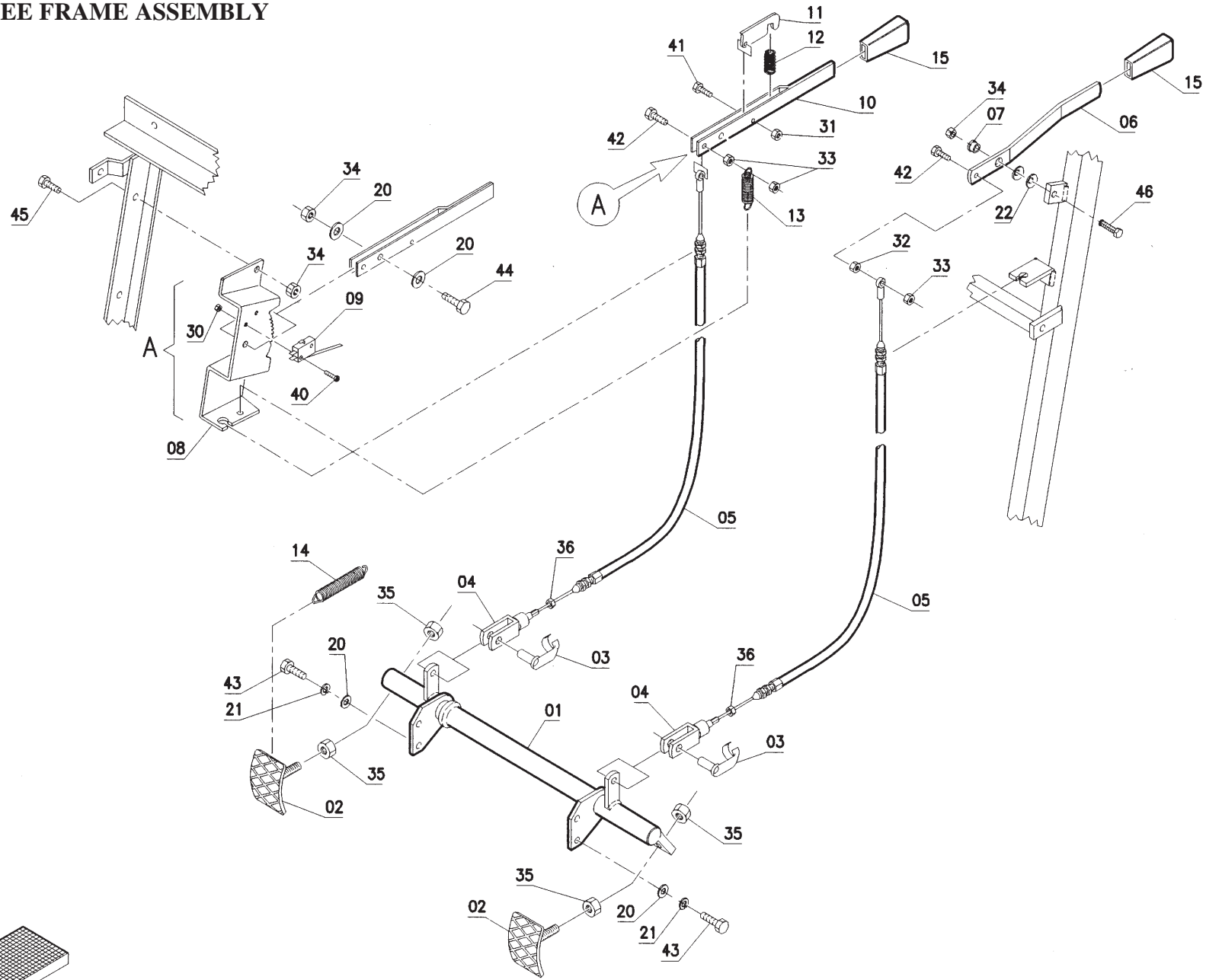

26B - DRAWING 06

Item	Part Number	Description	Qty.
1	40712060	Support	1
2	40712050	Joint	1
3	41203180	Pin	1
4	71600002	Clip	2
5	40712040	Arm	1
6	40712070	Support	2
7	69104070	Bushing	2
8	67010060	Wheel	2
9	69210590	Spring	2
10	74008010	Knob	2
12	40312190	Handwheel	1
13	40312180	Adjuster	1
14	69210040	Spring	1
15	40312100	Push Button	1
16	71502002	Split Pin	1
17	40312300	Adjuster	1
18	74400017	Split Pin	1
19	67404250	Sheath	1
20	40312310	Chain	1
21	70510801	Bearing	1
22	40312230	Arm	1
23	40312290	Roller	1
24	70220008	Seeger Ring	2
30	71108003	Washer: 8x17	
31	71110002	Washer: 10x21	
32	71108007	Washer: 9x24	
33	71121001	Washer: 21x37	
34	71116004	Washer: 17x30	
35	71308001	Lock Washer	
40	71020801	Lock Nut: M8	
41	71021002	Lock Nut: M16	
42	71011002	Nut: M10	
43	71010801	Nut: M8	
51	70911024	Screw: M10x60	
52	70910802	Screw: M8x14	
53	70910804	Screw: M8x20	
54	70910808	Screw: M8x25	
55	70910826	Screw: M8x50	

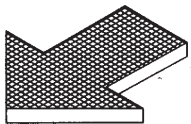
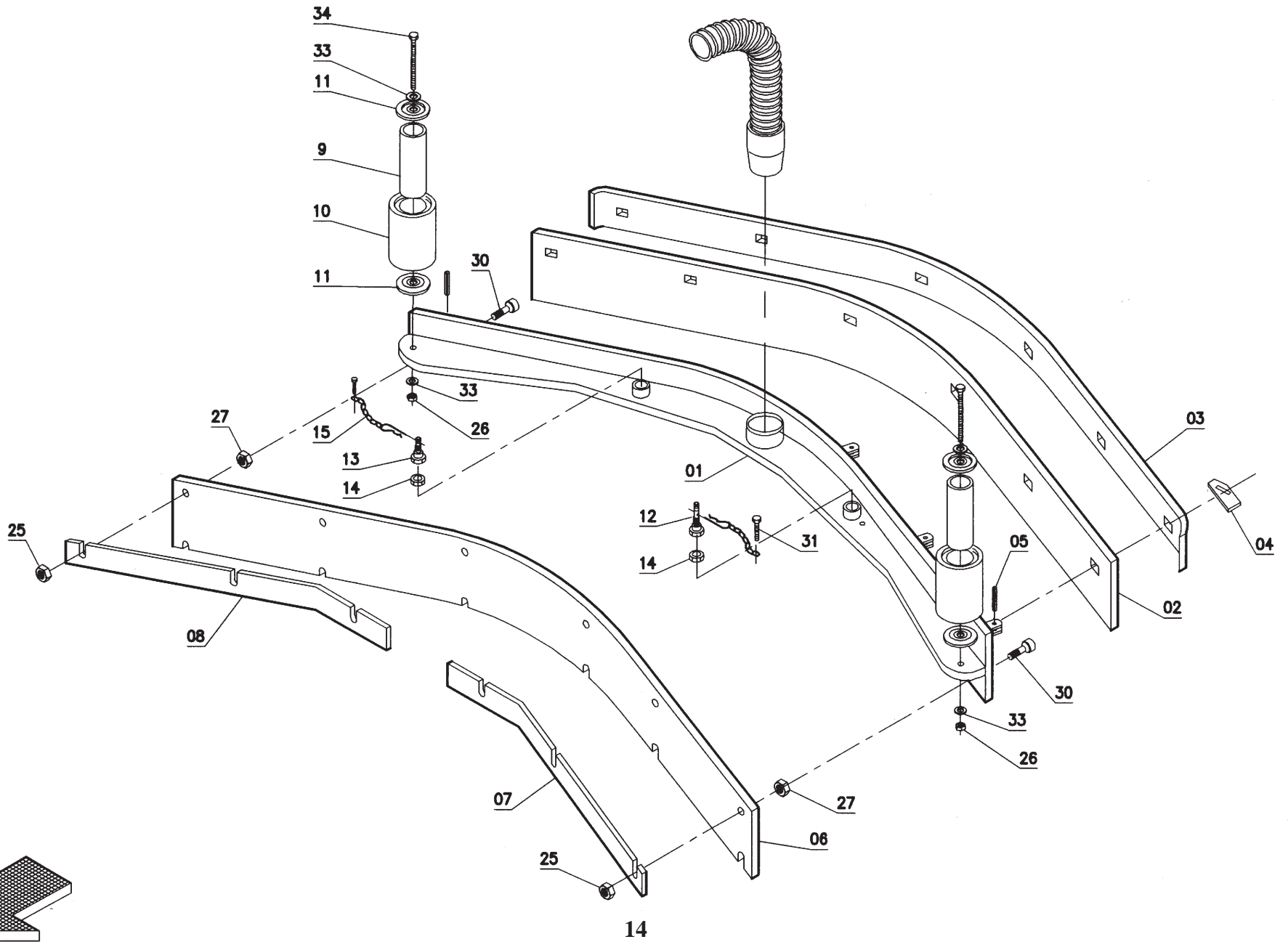

26B - DRAWING 07

Item	Part Number	Description	Qty.
1	69607060	Squeegee Body	1
2	67707130	Central Rubber 33 Shore	1
2	67707140	Central Rubber 40 Shore	1
3	68807060	Blade	1
4	41811060	Plate	6
5	71405002	Spring Pin	6
6	67707120	Front Rubber	1
7	68807070	Left Blade	1
8	68807050	Right Blade	1
9	40411010	Pin	2
10	67020080	Wheel	2
11	40711020	Pin	4
12	40311030	Stud Bolt	1
13	40711010	Stud Bolt	1
14	40311020	Special Nut	2
15	40711030	Chain with Pin	2
25	71020602	Lock Nut:	
26	71020603	Lock Nut	
27	71010607	Nut	
30	70980608	Screw: M6x25	
31	70940502	Screw: M5x10	
33	71110002	Washer	
34	70911030	Screw	
	A9607003	Squeegee Assembly	

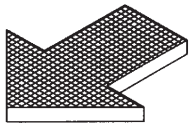
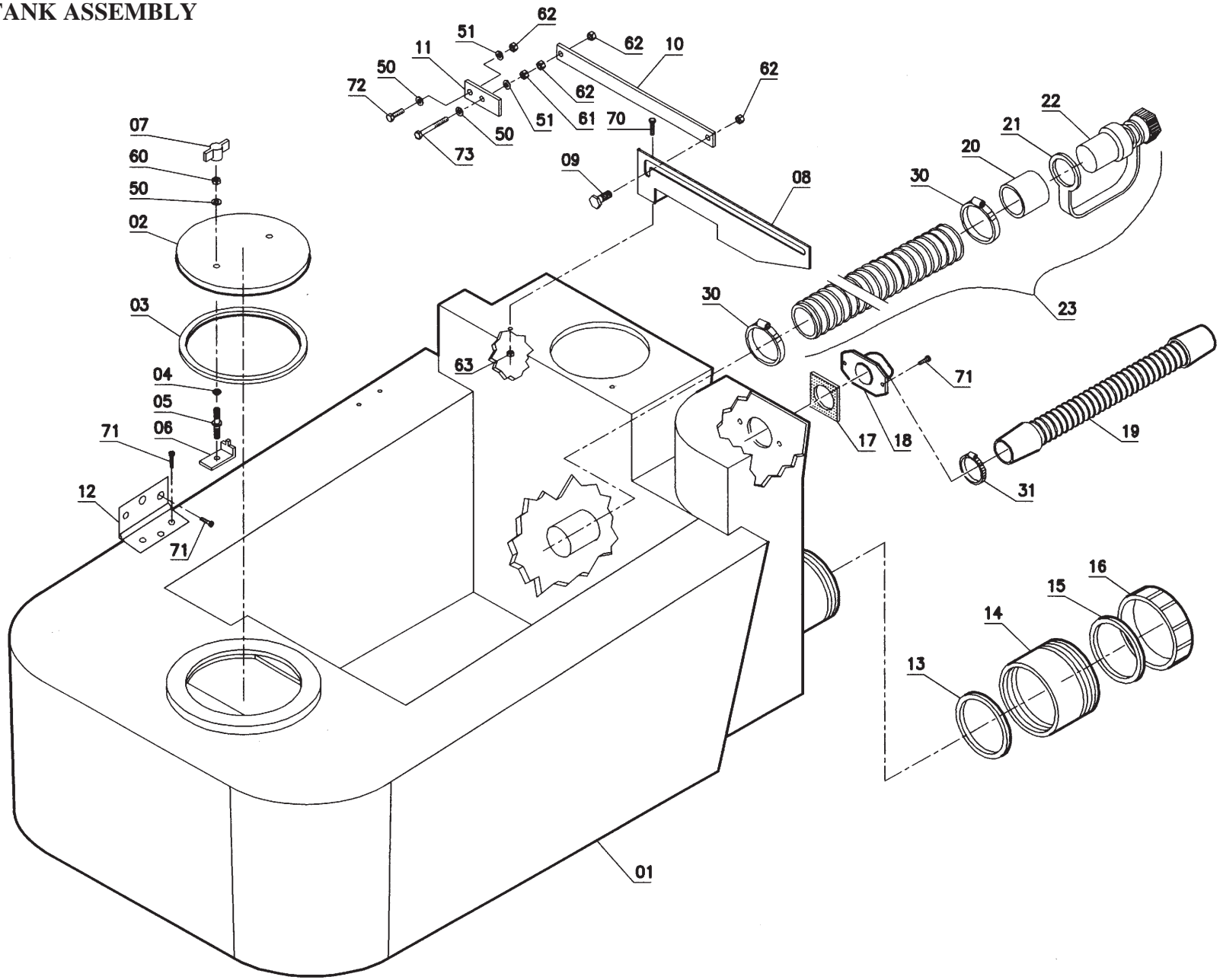

26B - DRAWING 08

Item	Part Number	Description	Qty.
1	69707030	Recovery Tank	1
2	40736130	Cover	1
3	67406080	Gasket	1
4	70800022	O-Ring	2
5	40736140	Stud Bolt	2
6	40736150	Holdfast	2
7	74008011	Wing Nut	2
8	40736080	Support	1
9	40736100	Stud Bolt	1
10	40736090	Prop	1
11	40736110	Plaque	1
12	40346280	Hinge	2
13	67406090	Gasket	1
14	40336250	Extension Tube	1
15	67400990	Gasket	1
16	40336170	Cover	1
17	67400090	Gasket	1
18	40741010	Coupling	1

Item	Part Number	Description	Qty.
19	67512560	Suction Hose	1
20	67300080	Pipe	1
21	40741020	Clamp	1
22	41036060	Cover	1
23	67523020	Hose Assembly	1
30	74220059	Clamp	2
31	74210003	Clamp	1
50	71108005	Washer: 8x17	
51	71108003	Washer: 8x 17	
60	71010804	Nut: M8	
61	71010801	Nut: M8	
62	71020801	Lock Nut: M8	
63	71020602	Nut: M6	
70	70910614	Screw: M6x25	
71	70945001	Screw: 5, 2x20	
72	70910809	Screw: M8x25	
73	70910818	Screw: M8x60	

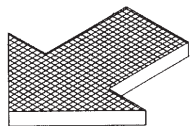
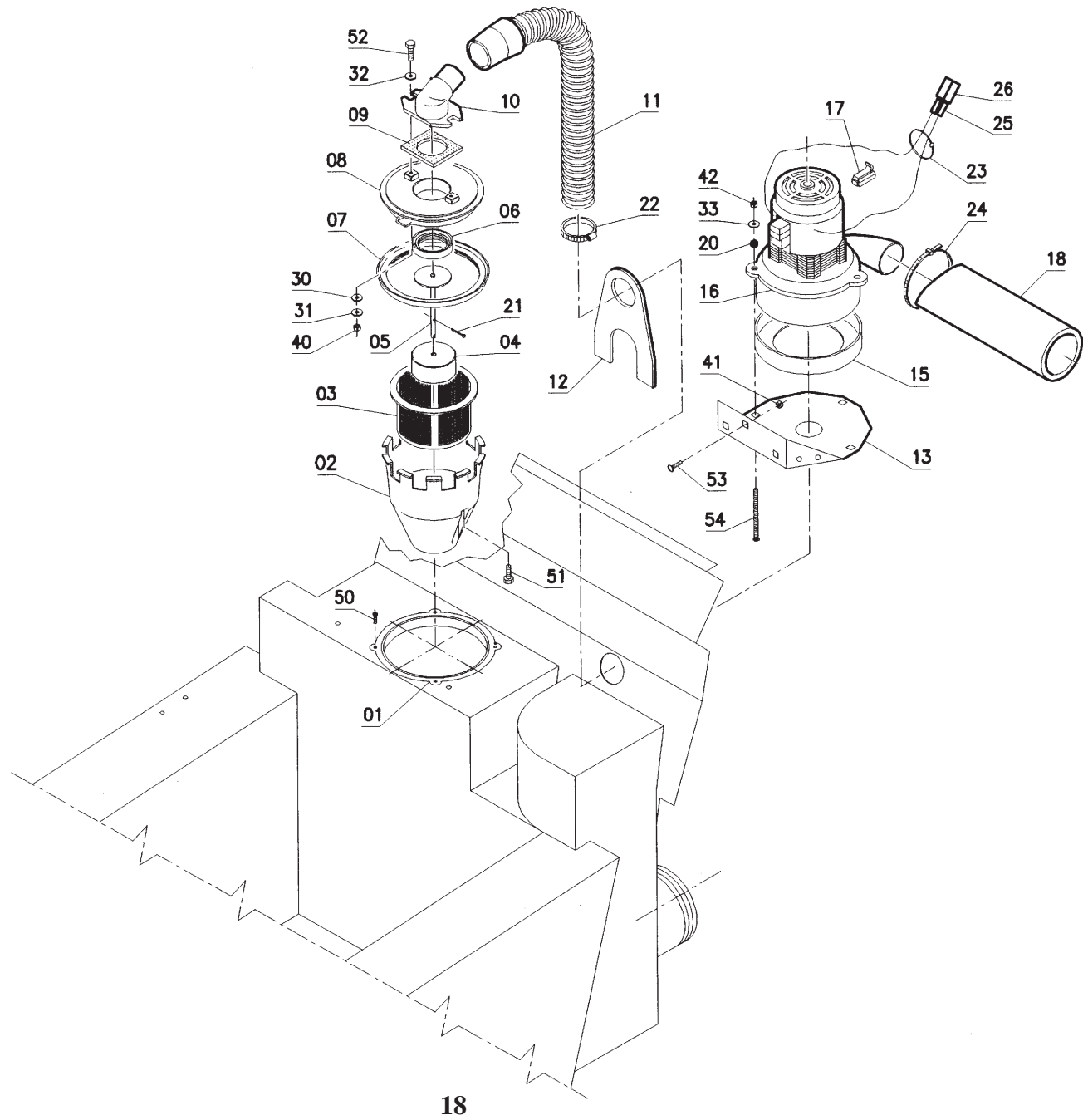

26B - DRAWING 09

Item	Part Number	Description	Qty.
1	42036030	Ring	1
*2	42036040	Protection	1
*3	66500010	Filter	1
*4	42041040	Float	1
*5	40336220	Rod	1
*6	67400110	Gasket	1
*7	67400510	Gasket	1
8	42041050	Cover	1
9	67400090	Gasket	1
10	40336110	Coupling	1
11	67512560	Suction Hose	1
12	40341050	Protection	1
13	40716300	Support	1
15	67401010	Shroud	1
16	68130330	Suction Motor	1
17	71707111	Carbon Brush Motor	2
18	67532100	Deadening Hose	1
20	72910002	Fairlead	3
*21	71502002	Split Pin	2
23	74210001	Clamp	2
24	74210003	Clamp	1
25	72700004	Contact	2
26	72700003	Connector	2
30	71104004	Washer: 4x12	
31	71104002	Washer: 4x9	
32	71105005	Washer: 5x20	
33	71106005	Washer: 6x18	
40	71010402	Nut: M4	
41	71020501	Lock Nut: M5	
42	71020601	Lock Nut: M6	
50	70943502	Screw: 3, 5x13	
*51	70943907	Screw: 3, 9x13	
52	70910404	Screw: M4x25	
53	70900501	Screw: M5x16	
54	70900603	Screw: M6x100	
*	A6503001	Filter Assembly	

SOLUTION TANK ASSEMBLY

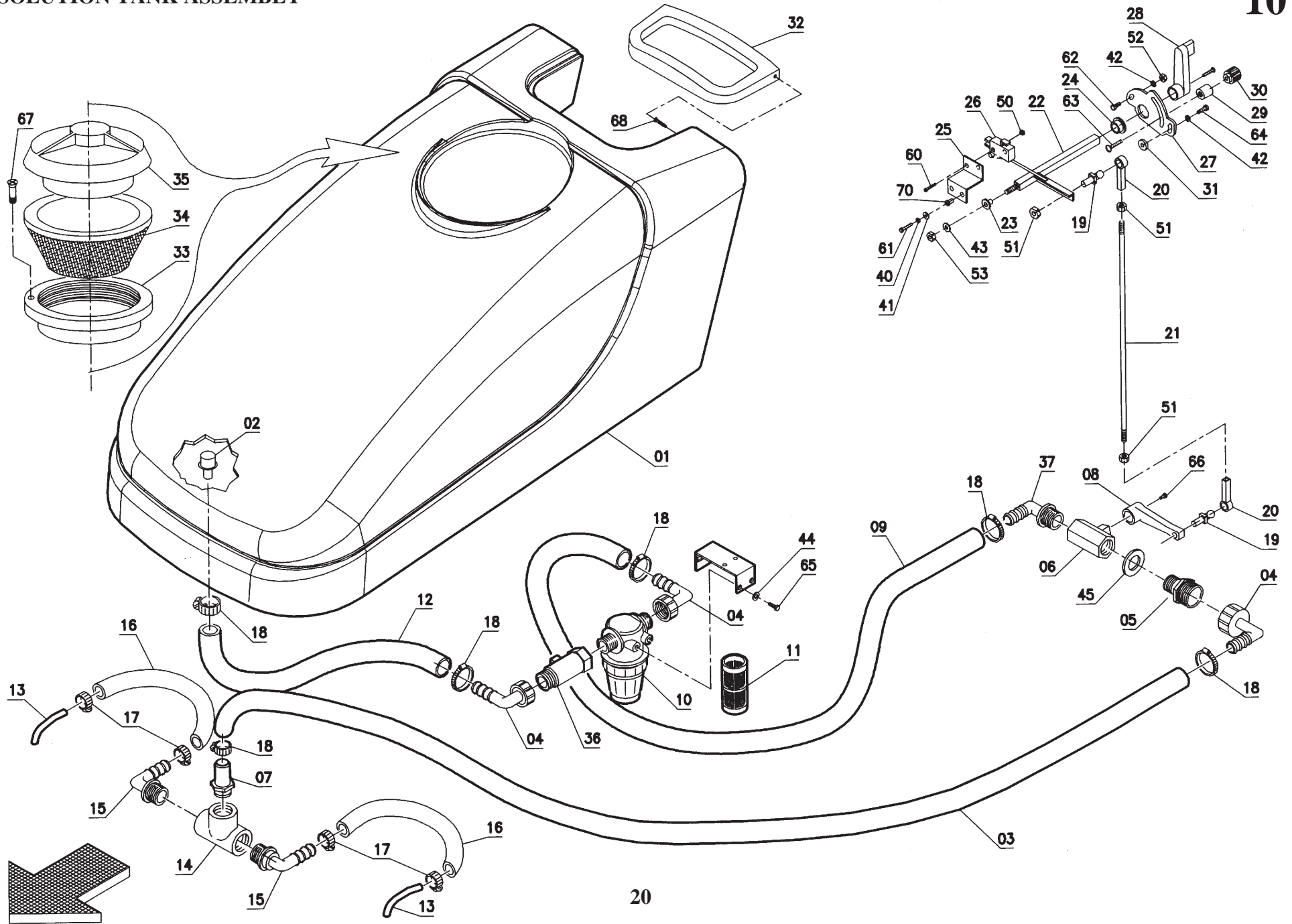

26B - DRAWING 10

Item	Part Number	Description	Qty.
1	69707040	Solution Tank	1
2	74540024	Connector	1
3	67523140	Hose	1
4	74520011	Connector	3
5	74560009	Nipple	1
6	74510001	Cock	1
7	40337040	Connector	1
8	40237030	Cock Lever	1
9	67523080	Hose	1
10	66500120	Filter	1
11	66500150	Filter Cartridge	1
12	67522380	Hose	1
13	40701170	Pipe	2
14	74530001	Fitting	1
15	74520015	Fitting	2
16	67522630	Hose	2
17	74220056	Clamp	4
18	74220061	Clamp	4
19	74400013	Pin	2
20	74400007	Adjustable Head	2
21	40337050	Rod	1
22	40337060	Cock Lever	1
23	69101060	Bushing	1
24	69102280	Bushing	1
25	40716350	Support	1
26	72105009	Microswitch	1
27	40736160	Adjuster	1
28	40736180	Cock Lever	1

Item	Part Number	Description	Qty.
29	40736170	Spacer	1
30	74005001	Knob	1
31	40504010	Special Washer	1
32	40746110	Door	1
33	41036040	Ring with Gasket	1
34	66500180	Filter	1
35	41036030	Cover	1
36	74510008	Cock	1
40	71304001	Lock Washer	
41	71104003	Washer: 4x12	
42	71105002	Washer: 5x11	
43	71106001	Washer: 6x12	
44	71108003	Washer: 8x17	
45	71121001	Washer: 21z37	
50	71020301	Lock Nut: M3	
51	71010501	Nut: M5	
52	71030501	Nut Brass: M5	
53	71020601	Lock Nut: M6	
60	70940303	Screw: M3x20	
61	70910401	Screw: M4x12	
62	70910501	Screw: M5x8	
63	70900502	Screw: M5x25	
64	70910505	Screw: M5x20	
65	70910803	Screw: M8x16	
66	70920411	Screw: 3/16x1/4"	
67	70943904	Screw: 3, 9x19	
68	70943903	Screw: 3, 9x16	
70	74806002	Insert: M4	2

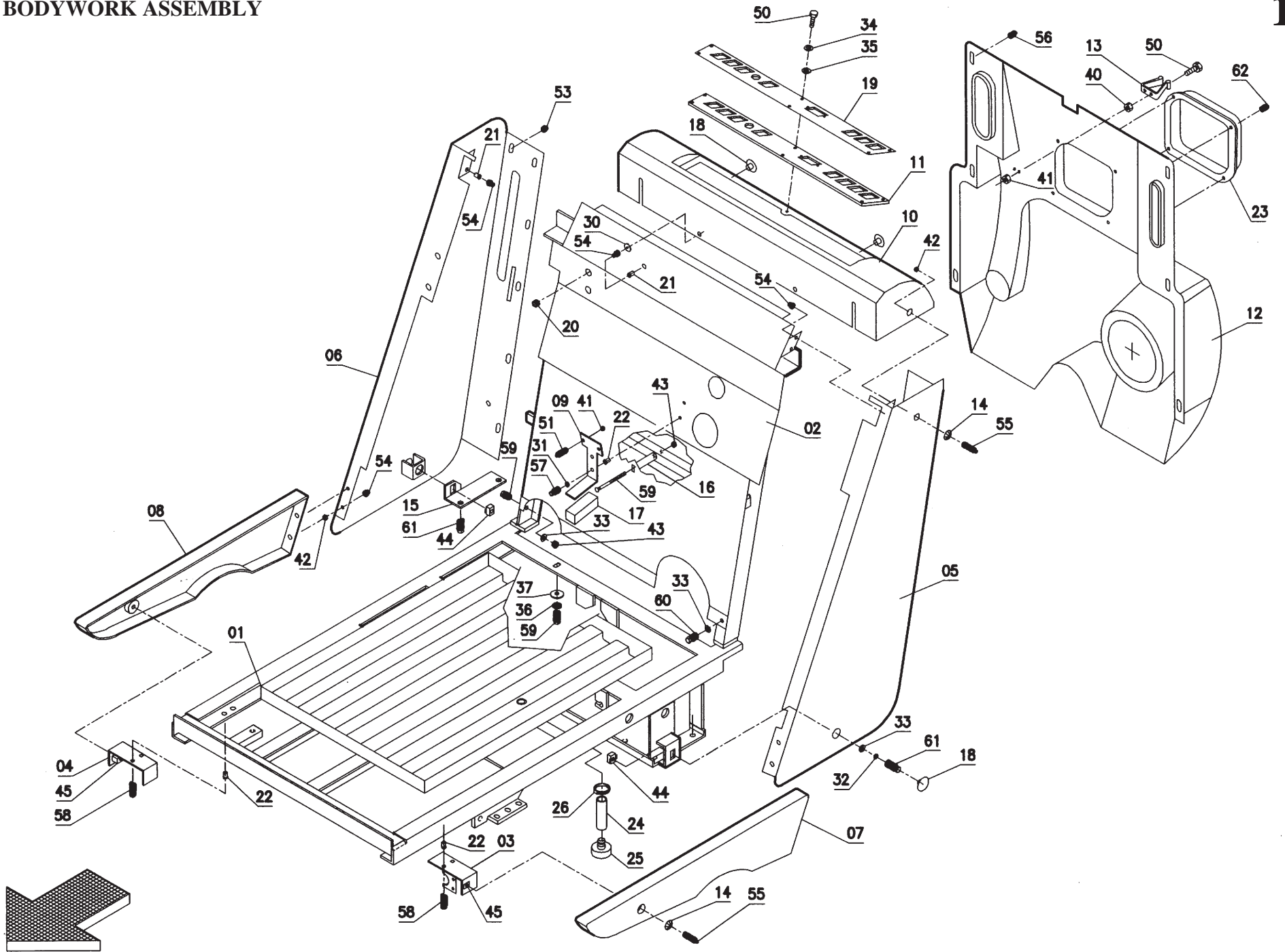

26B - DRAWING 11

Item	Part Number	Description	Qty.
1	40716390	Panel	1
2	40716290	Plate	1
3	40737020	Left Support	1
4	40716320	Right Support	1
5	40746080	Panel Left	1
6	40746090	Panel Right	1
7	40746140	Cover Left	1
8	40746130	Cover Right	1
9	40316270	Support	1
10	40746100	Instrument Board	1
11	40746160	Plate	1
12	40746120	Rear Cover	1
13	69230120	Hook	1
14	40247030	Washer: 5x20	4
15	40716380	Support	1
16	40303040	Spacer	1
17	67400710	Gasket	1
18	72913003	Cap	3
19	66401298	Decal	1
20	72910002	Fairlead	2
21	74806012	Insert: M5	
22	74806010	Insert: M6	
23	40346290	Cover	1
24	67522240	Pipe	1
25	41336110	Cover	1
26	74220061	Clamp	1

Item	Part Number	Description	Qty.
30	71105005	Washer: 5x20	
31	71106001	Washer: 6x12	
32	71308001	Lock Washer	
33	71108003	Washer: 8x17	
34	71104001	Washer: 4x9	
35	71104006	Washer	
36	71108009	Lock Washer	
37	71108007	Washer	
40	71010401	Nut: M4	
41	71020401	Lock Nut: M4	
42	71020501	Lock Nut: M5	
43	71020801	Lock Nut: M8	
44	71050801	Nut: M8	
45	71050503	Nut: M5	
50	70920405	Screw: M4x16	
51	70910409	Screw: M4x30	
53	70940502	Screw: M5x10	
54	70910502	Screw: M5x12	
55	70950503	Screw: M5x16	
56	70940503	Screw: M5x20	
57	70910607	Screw: M6x16	
58	70980608	Screw: M6x20	
59	70910804	Screw: M8x20	
60	70910806	Screw: M8x22	
61	70910806	Screw: M8x22	
62	70940401	Screw: M4x20	

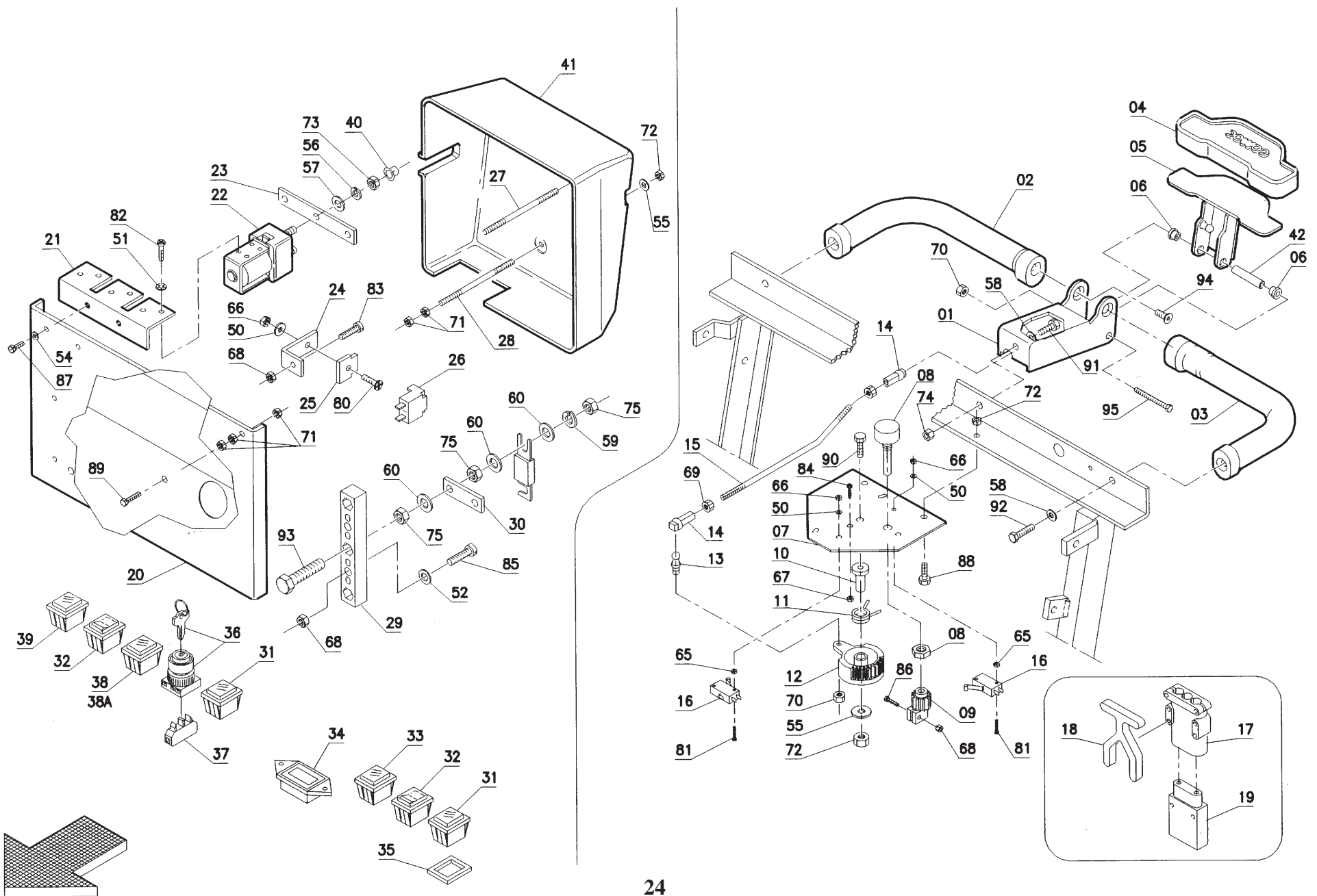

26B - DRAWING 12

Item	Part Number	Description	Qty.
1	41628060	Support	1
2	69516030	Handle Bar Right	1
3	69516040	Handle Bar Left	1
4	41628050	Cover	1
5	41628040	Lever	1
6	69115080	Bushing	2
7	40328110	Control Base	1
8	72108001	Potentiometer	1
9	41628020	Pinion	1
10	69115070	Bushing	1
11	69230440	Spring	1
12	41628010	Cam Wheel	1
13	74400013	Pin	1
14	74400007	Adjustable Head	2
15	40328100	Tie Rod	1
16	72105001	Microswitch	2
17	72700014	Connector Male	1
18	72700015	Lever for Connector	1
19	72700013	Connector Female	1
20	40716310	Panel	1
21	40351070	Support	1
22	68430110	Remote Control Switch	3
23	41651020	Bridge	1
24	41251100	Support	1
25	72916001	Plaque	1
26	72400011	Fuseholder	1
27	40541020	Stud Bolt	2
28	40136010	Stud Bolt	1
29	72400007	Fuseholder	2
30	41251090	Bridge	1
31	72300111	Signal Lamp Green	2
32	72102005	Switch	2
33	72300117	Battery Warning Light	1
34	72904002	Hour Meter	1
35	67400160	Gasket	7
36	72199012	Switch with Keys	1
37	72107004	Contact	1
38	72300216	Cover	1
38A	72300116	Signal Lamp Yellow	1
39	72300115	Signal Lamp Red	1

Item	Part Number	Description	Qty.
40	72913006	Cover	6
41	40351060	Protection	1
42	41628090	Pin	1
50	71103002	Washer: 3x8	
51	71304001	Lock Washer	
52	71104002	Washer: 4x9	
54	71106001	Washer: 6x12	
55	71106005	Washer: 6x18	
56	71108009	Lock Washer	
57	71108004	Washer Brass	
58	71108003	Washer: 8x17	
59	71110007	Lock Washer	
60	71110010	Washer Brass	
65	71010302	Nut Brass: M3	
66	71020301	Lock Nut: M3	
67	71010401	Nut: M4	
68	71020401	Lock Nut: M4	
69	71010501	Nut: M5	
70	71020501	Lock Nut: M5	
71	71010601	Nut: M6	
72	71020601	Lock Nut: M6	
73	71010805	Nut Brass: M8	
74	71020801	Lock Nut: M8	
75	71011007	Nut Brass: M10	
80	70970301	Screw: M3x10	
81	70940303	Screw: M3x20	
82	70920401	Screw: M4x6	
83	70920403	Screw: M4x10	
84	70920405	Screw: M4x16	
85	70920406	Screw: M4x20	
86	70910402	Screw: M4x20	
87	70910605	Screw: M6x14	
88	70910607	Screw: M6x16	
89	70910613	Screw: M6x25	
90	70930607	Screw: M6x40	
91	70910803	Screw: M8x16	
92	70910804	Screw: M8x20	
93	70911002	Screw: M10x16	
94	70980801	Screw: M8x14	
95	70910512	Screw: M5x60	

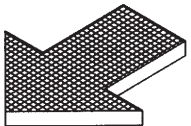
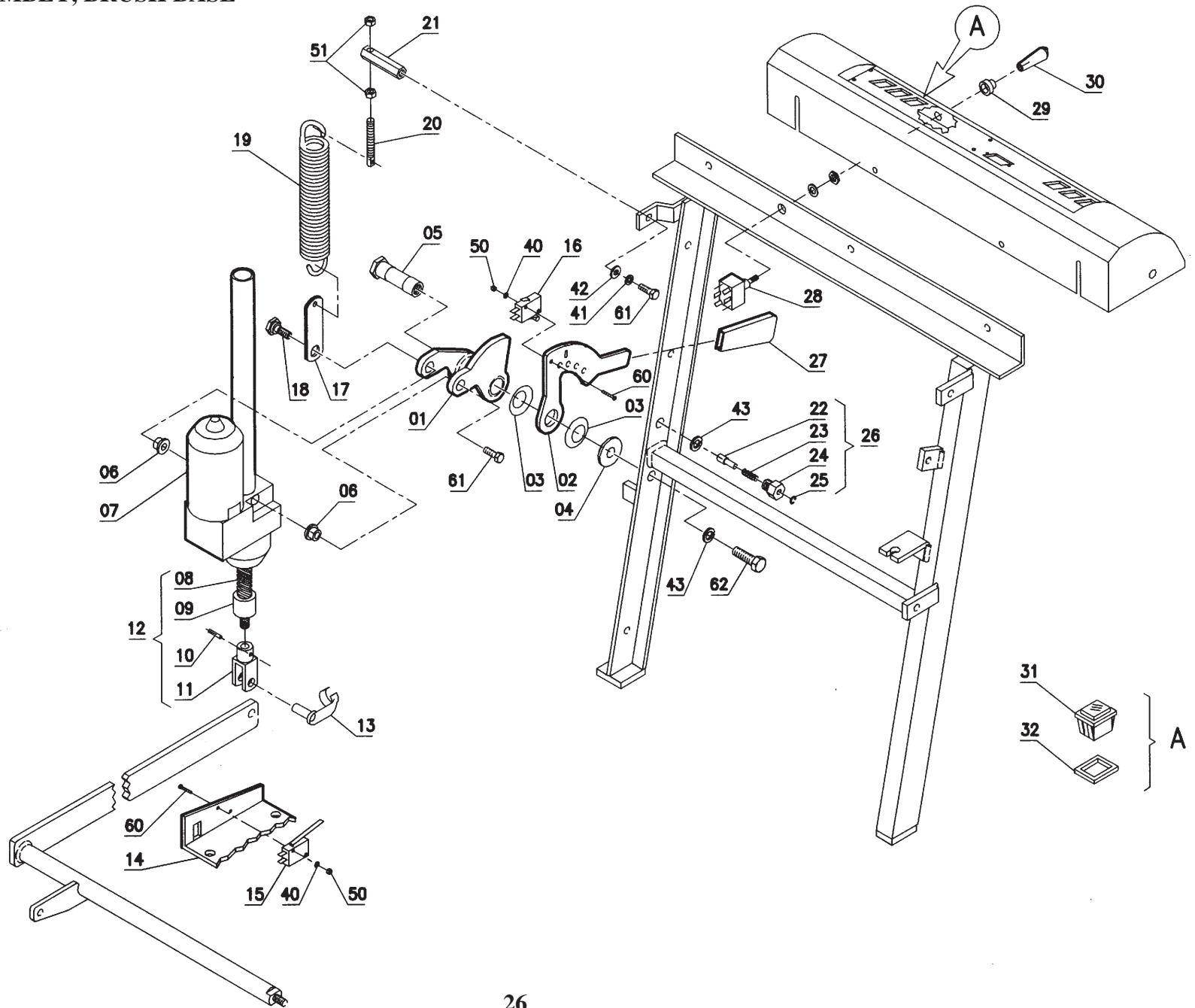

26B - DRAWING 13

Item	Part Number	Description	Qty.
1	40703290	Support	1
2	40703340	Lever	1
3	71120002	Washer	2
4	40703280	Bushing	1
5	40703310	Pin	1
6	69106020	Bushing	2
7	66200400	Actuator Assembly	1
8	66250010	Threaded Shaft	1
9	66250020	Spacer	1
10	71403001	Spring Pin	1
11	74610002	Fork	1
12	66250040	Shaft	1
13	74620002	Pin	1
14	40716340	Right Support	1
15	72105013	Microswitch	1
16	72105012	Microswitch	1
17	40303360	Tie Rod	1
18	40703300	Special Screw	1
19	69220450	Spring	1
20	40212050	Tie Rod	1

Item	Part Number	Description	Qty.
21	40703330	Stud Bolt	1
22	40703350	Pin	1
23	69210580	Spring	1
24	40703360	Bracket	1
25	70230006	Seegeer Ring	1
26	40703400	Pin Assembly	1
27	74100005	Knob	1
28	40651110	Commutator	1
29	72908005	Cap	1
30	74100050	Knob	1
40	71103001	Washer	
41	71108009	Lock Washer	
42	71108003	Washer	
43	71112006	Lock Washer	
50	71020301	Lock Nut	
51	71010801	Nut	
60	70940303	Screw	
61	70910804	Screw	
62	70911202	Screw	

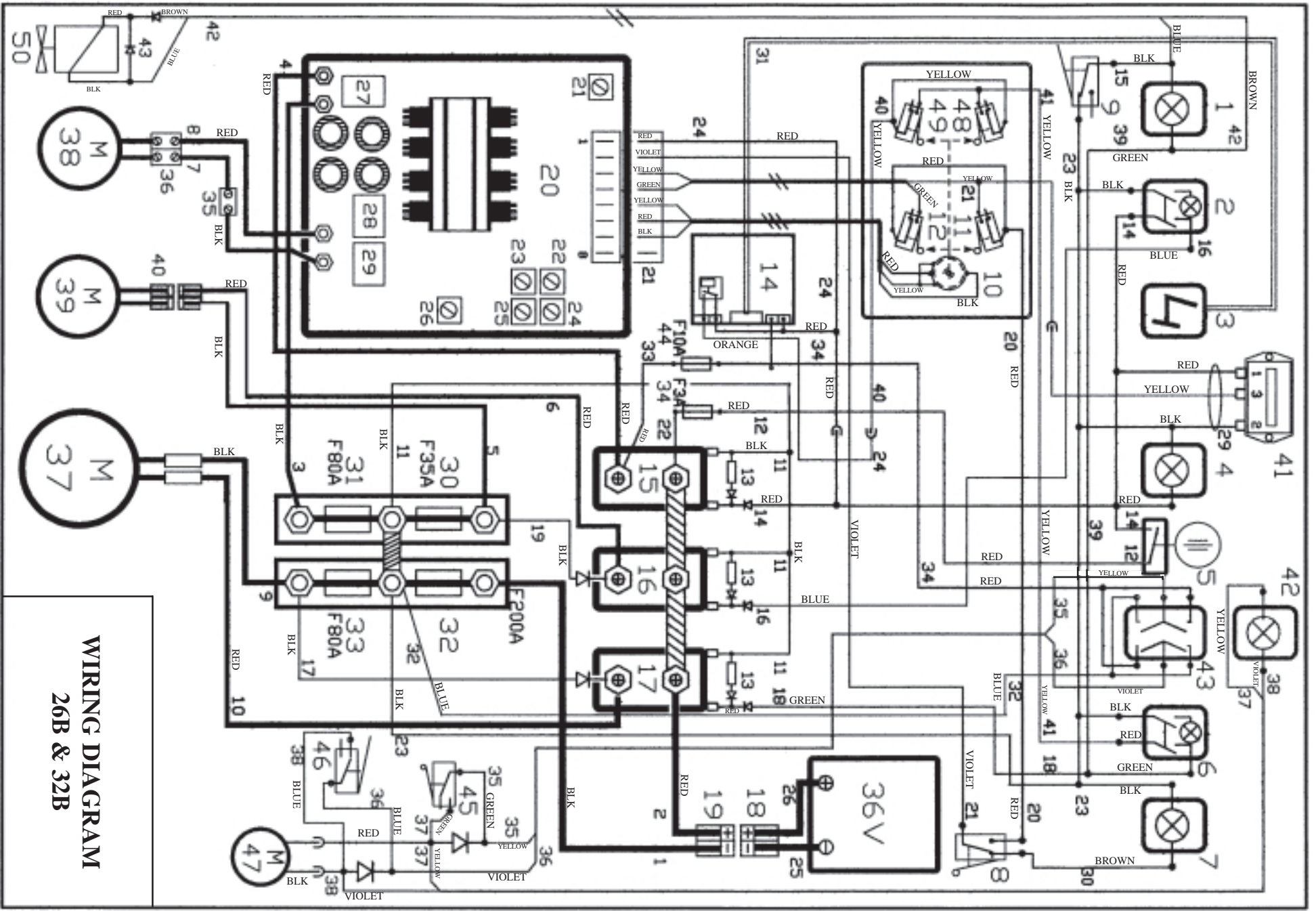

**WIRING DIAGRAM
26B & 32B**

**COMPONENTS - ELECTRICAL SYSTEM
26B & 32B**

Item	Part Number	Description	Qty.
1	72300111	Indicator Lamp Green	
2	72102005	Switch with Green Lamp	
3	72300117	Indicator Battery Control	
4	72300111	Indicator Lamp Green	
5	72107004	Contact On/Off Key	
6	72102005	Switch with Green Lamp	
7	72300115	Indicator Lamp Red	
8	72105009	Microswitch	
9	72105009	Microswitch	
10	72108001	Potentiometer Drive	
11	72105001	Microswitch	
12	72105001	Microswitch	
14	67903001	Batteries Check Card	
15	68430110	Remote Control Switch	
16	68430110	Remote Control Switch Suction Mtr	
17	68430110	Remote Control Switch Brushes Mtr	
18	72700014	Male Connector 80A	
19	72700013	Female Connector 80A	
20	67900041	Chopper Card 36V 70A MOS	
21		Trimmer Regulation Maximum Current	
22		Trimmer Regulation Minimum Volt	
23		Trimmer Regulation Acceleration	
24		Trimmer Regulation Maximum Volt	
25		Trimmer Regulation Reduction Reverse Motion	
26		Trimmer Regulation Braking	

Item	Part Number	Description	Qty.
27		Relay General	
28		Relay	
29		Relay	
30	72403502	Fuse 35A Suction Motor	
31	72408001	Fuse 80A Chopper Card	
32	72420002	Fuse 200A General Batteries	
33	72408001	Fuse 80A Brushes Motor	
34	72400301	Fuse 3A Faston	
35	67200210	Terminal 10x1 Geared Motor	
36	67200220	Terminal 10x2 Geared Motor	
37	68230900	Brushes Motor 26/32	
38	68200220	Geared Motor W/differential 36V	
39	68130330	Suction Motor	
40	72700007	Double Connector 30A Vac Motor	
41	72904002	Hourmeter Digital	
42	72300116	Indicator Lamp Yellow	
43	40651110	Control Up/Down Brushes	
44	72401001	Fuse 10A Faston	
45	72105012	Microswitch Stop Brushes Down	
46	72105013	Microswitch Stop Brushes UP	
47	66200400	Base - Actuator Brush	
48	72105001	Microswitch Consent Brush Forward Movement	
49	72105001	Microswitch Consent Brush Backward Movement	
50	68533010	Solenoid Valve 36V 3/8" 14W	

**CABLES - ELECTRICAL SYSTEM
26B & 32B**

Item	Part Number	Description	Qty.	Item	Part Number	Description	Qty.
1-2	68003020	2 Cables Red - Black		25	68003022	2 Cables Red - Black 16x800 - 25-26 with	
3	68001034	Cable Black		26		Connector	
4	68001035	Cable Red		27	68000153	Cable + - Battery W/Screw & Nut	
5-6	68001036	2 Cables Red - Black		28	68000240	Cable + - Battery W/Screw & Nut	
7-8	68001037	2 Cables Red - Black		29	68003012	Cable Hourmeter	
9-10	68003005	2 Cables Red - Black		30	68001067	Cable Brown	
11	68001052	4 Cables Black		31	68000892	Cable Display (Battery Indicator)	
12	68003006	Cable Red		32	68003013	2 Cable Blue	
13	72500016	Diode 270 IN400/with Faston		33	68003014	Cable Red	
14	68003007	4 Cables Red		34	68003015	2 Cables Red	
15	68003008	Cable Black		35	68003016	2 Cables Yellow-Green w/Diode	
16	68003009	Cable Blue		36	68003017	2 Cables Violet-Blue w/Diode	
17	68001043	Cable Black		37	68003018	3 Cables Green-Red- Yellow	
18	68003010	Cable Green		38	68003019	3 Cables Blue-Black-Violet	
19	68001045	Cable Black		39	68003026	Cable Green	
20	68001046	2 Cables Red		40	68003027	2 Cables Yellow	
21	68003021	7 Cables for Chopper Card		41	68003028	2 Cables Yellow	
22	68001066	Cable Red		42	68003029	2 Cables Brown-Blue	
23	68003011	Cable Black		43	72500008	Diode IN4007 with Faston	
24	68001049	4 Cables, Red, Red, Red, Orange					

FUNCTIONAL SCHEMATIC 26B & 32B

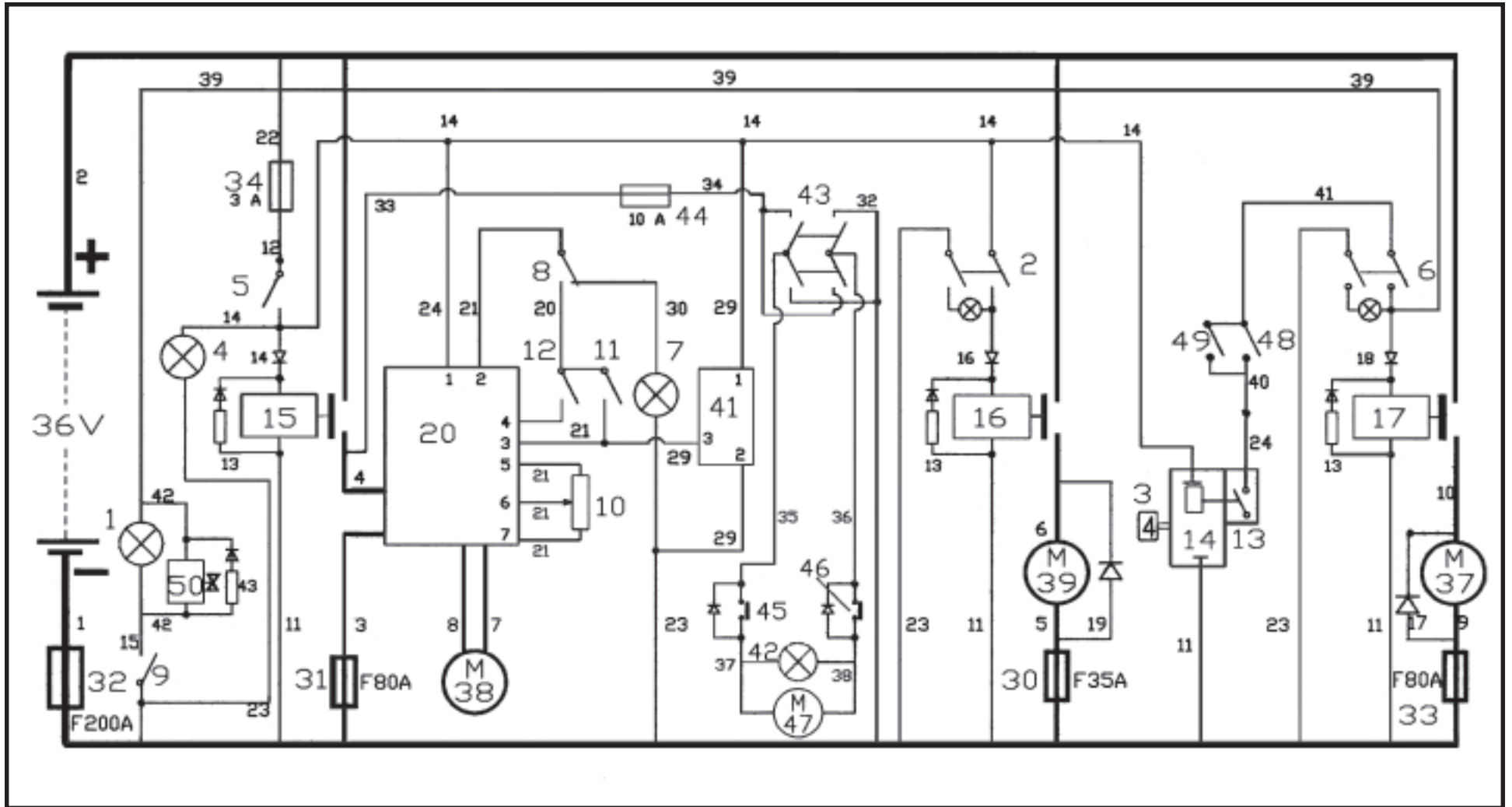

CHOPPER CARD 67900041

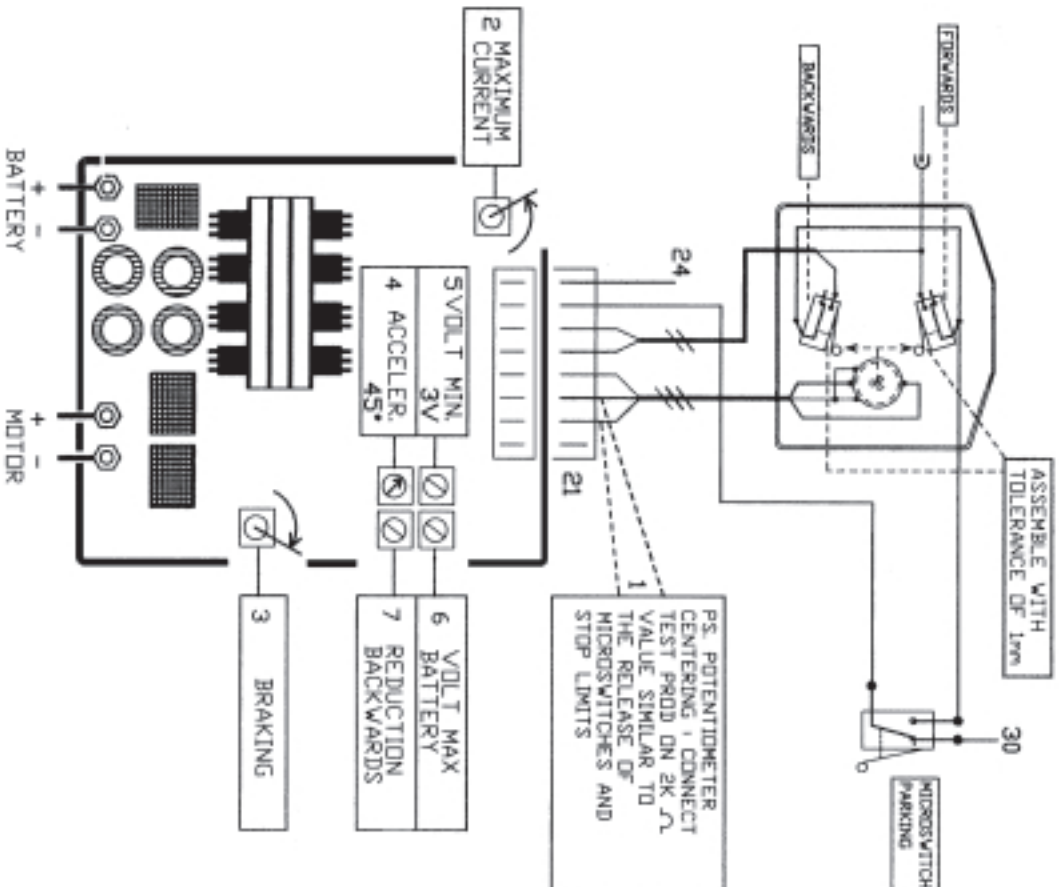

CHOPPER CARD ALARM DESCRIPTIONS

PART NUMBER 67900041

ALARMS (LED red)	
<u>NUMBER OF BLINKS</u>	<u>ALARM DESCRIPTIONS</u>
1	Electronic card has a short circuit or #15 relay on (closed) at power on or in stop position.
2	Forward microswitch is on at power on.
3	Backward switch is on at power on.
4	Potentiometer not at the central position at power on (>0.3V).
5	Broken potentiometer or wrong position (>4.7V).
6	Microswitches forward and backward are both on.
ALWAYS ON	Thermic protection within the chopper card has opened the circuit.
	<p><u>NOTES:</u></p> <p>If an alarm is present at power on, the machine will not move.</p> <p>Alarms 4, 6 and the thermic protection alarm will stop the machine if they occur while moving.</p> <p>If more than one alarm has occurred, the first alarm is indicated, while the other alarms remain stored. Upon eliminating the first alarm, the next one will be indicated.</p> <p>To reset the alarms, the potentiometer and the forward and backward microswitches must be in the central position.</p>

Refer to Chopper Card File

Refer to Chopper Card File

NOTES

SERVICE LOG

WARRANTY POLICY
PACIFIC STEAMEX INC. LIMITED WARRANTY

The **Pacific Steamex** Inc. ScrubMaster has been manufactured, tested and inspected in accordance with specific engineering requirements. This machine is **WARRANTED** to be free from defects in workmanship and materials for periods as follows from the date of purchase.

Ten (10) Years – Polyethylene Components

Five (5) Years – Main Frame

Two (2) Years – Brush Drive Motors

One (1) Year – All other components unless excluded below

This warranty extends to the original user/purchaser and only when used, operated and maintained in accordance with **Pacific Steamex** Inc. Operating and Maintenance instructions.

This warranty does not apply to certain wear parts and accessories of the machine such as electrical cords, carbon motor brushes, floor brushes, belts, hoses, tools, squeegee blades, etc., nor does it apply to damage or failure caused by improper use, abuse or neglect. Warranty credit or replacement of return parts including motors, pumps, etc., is subject to incoming inspection of those items.

To secure repair under this warranty, the following procedure should be taken:

1. The inoperative machine or warranted parts must be delivered to the authorized dealer with shipping and delivery charges prepaid. If unable to locate the Dealer, you may contact **Pacific Steamex** Inc. at the address listed herein for the location of the nearest **Pacific Steamex** Inc. repair center or agent or for other instructions pertaining to your warranty difficulty.
2. Upon compliance with the above warranty procedure, all warranted repairs will be completed at no additional charge or cost to the user.
3. Only **Pacific Steamex** Inc. or its authorized dealers and agents may make no charge warranty repairs on this product. All others do so at their own risk.

This warranty limits **Pacific Steamex** Inc. liability to the repair of the product and/or warranted parts replacement and does not include incidental or consequential damages arising from the use of a **Pacific Steamex** Inc. machine whether defective or not.

BATTERY WARRANTY

In addition to the terms above, any original equipment Pacific Steamex Battery which becomes unserviceable under normal use within a period of ninety (90) days from date of sale to the original user will be repaired or replaced with one of equal specification at our option, F.O.B. any authorized Pacific Steamex Sales or Service Branch, with no charge to user, except transportation costs. After the expiration of the above ninety (90) day period, any battery which fails under normal use will be adjusted to the original user with a new battery of equal specification on a twelve (12) month pro rata basis from the date of purchase. Adjustment will be determined using the then current list price, plus transportation costs. Warranty is rendered null and void if battery is not kept filled to the proper level with **DISTILLED WATER**.

This warranty is in lieu of all other expressed or implied warranties and is extended to the original purchaser/user.

PACIFIC STEAMEX, INC.
2259 S. SHERIDAN
MUSKEGON, MICHIGAN 49442-6252
1-800-968-1332
FAX 1-800-863-9536