



T7AMR

Rider-Scrubber

Machine Serial Number Range
(S/N 10000000-20000000)

Parts Manual

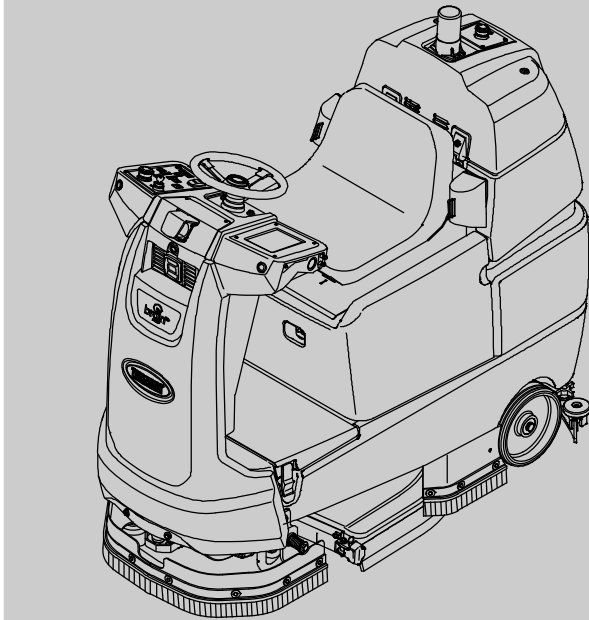
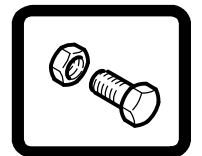

Hygenic[®] Fully Cleanable Tanks



For the latest Parts manuals and other language Operator manuals, visit:

www.tennantco.com/manuals

North America / International / Japan

www.tennantco.com

9018142
Rev. 00 (11-2018)



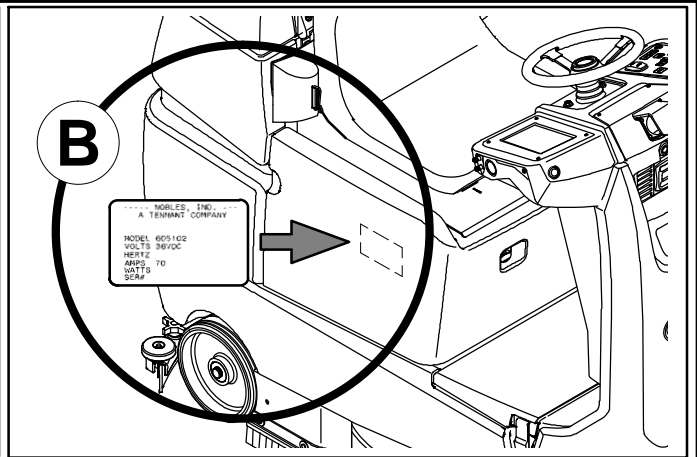
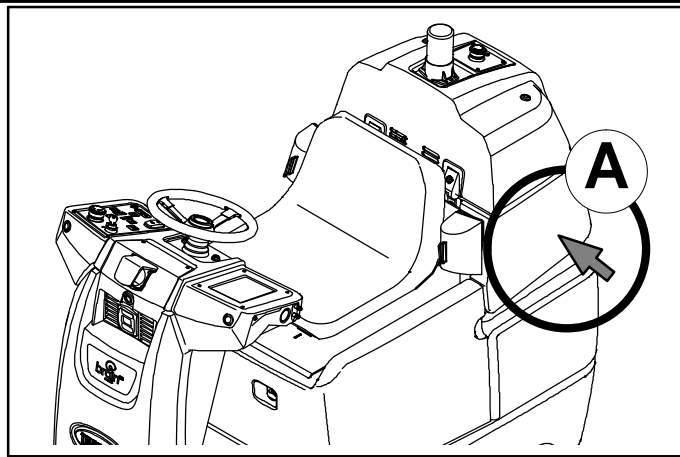

Ref	Part No.	Serial Number	Description	Qty.
1	82681	(000000—)	Bracket Wldt, Lpg Mount	1
2	63810	(000000—)	Latch Assy, Lpg Tank Mtg, W/Nut	4
3	51839	(000000—)	Nut Adjustable, Lpg Tank Mtg	2
4	49263	(000000—)	Tie, Cable	3
5	82556	(000000—001039)	Bracket, Vaporizer	1
6	54930	(000000—)	Vaporizer, LPG	1

HOW TO ORDER PARTS – See diagram above

Only use TENNANT Company supplied or equivalent parts. Parts and supplies may be ordered online, by phone, by fax or by mail.

Follow the steps below to ensure prompt delivery.

1. **(A)** Identify the machine model.
2. **(B)** Identify the machine serial number from the data label.
3. **(C)** Ensure the proper serial number is used from the parts list.
4. Identify the part number and quantity. Do not order by page or reference numbers.
5. Provide your name, company name, customer ID number, billing and shipping address, phone number and purchase order number.
6. Provide detail shipping instructions.

- (D)** ▽ – identifies an assembly
 ▲ – identifies parts included in assembly

Please fill out at time of installation for future reference.

Model No. – _____
 Serial No. – _____
 Machine Options – _____
 Sales Rep. – _____
 Sales Rep. phone no. – _____
 Customer ID Number – _____
 Installation Date – _____

Tennant Company
 PO Box 1452
 Minneapolis, MN 55440 USA
 Phone: (800) 553-8033
 www.tennantco.com

TENNANT Company Japan
 Sanka Bldg. 5F
 2-9 Minami Saiwai-cho
 Saiwai-Ku
 Kawasaki, Kanagawa 212-0016
 Tel: 044-556-1201
 Fax: 044-556-1202
 www.tennant.co.jp

Specifications and parts are subject to change without notice.

Copyright © 2018 TENNANT Company, Printed in U.S.A.

JP	<p>パーツの発注方法 ? 上記の図を参照してください TENNANT社製のパーツまたは同等品のみをお使いください。 パーツやサプライ品のご注文は、オンライン、電話、FAX、または手紙でお願いいたします。 確実にお届けできるように、以下の情報お知らせください。</p> <ol style="list-style-type: none"> 1. (A) 製品のモデル名をお知らせください。 2. (B) 製品のデータラベルに印刷されているシリアル番号をお知らせください。 3. (C) パーツリストを参照して、シリアル番号が正しいかご確認ください。 4. パーツ番号と数量をお知らせください。マニュアル/カタログのページ番号や参照番号でのご注文はご遠慮ください。 5. お客様のお名前、会社名、顧客ID番号、請求/発送先住所、電話番号、注文書番号をお知らせください。 6. 発送に関するご希望があれば、明記してください。 <hr/> <p>(D) ▽ - アセンブリを示します ▲ - アセンブリに含まれるパーツを示します</p>	<p>後日確認できるように、設置時に記入してください。</p> <p>モデルNo. - _____</p> <p>シリアルNo. - _____</p> <p>製品のオプション - _____</p> <p>販売代理店 - _____</p> <p>販売代理店の電話番号 - _____</p> <p>顧客ID番号 - _____</p> <p>設置日 - _____</p>
-----------	--	---

ES	<p>CÓMO SOLICITAR PIEZAS – Consulte el diagrama anterior.</p> <p>Utilice sólo las piezas suministradas por TENNANT Company o piezas equivalentes. Puede solicitar las piezas a través de internet, por teléfono, por fax o por correo.</p> <p>Siga los siguientes pasos para que la entrega sea rápida.</p> <ol style="list-style-type: none"> 1. (A) Indique el modelo de máquina. 2. (B) Indique el número de serie de la etiqueta de datos. 3. (C) Asegúrese de que indica el número de serie correcto de la lista de piezas. 4. Indique la cantidad y el número de la pieza. No realice el pedido indicando el número de página o el de referencia. 5. Incluya su nombre, el nombre de la empresa, el ID de cliente, las direcciones de envío y facturación, el número de teléfono y el número del pedido de compra. 6. Facilite instrucciones de envío. <hr/> <p>(D) ▽ - identifica un conjunto ▲ - identifica piezas de un conjunto</p>	<p>Rellene estos datos cuando realice la instalación para utilizarlos como referencia en el futuro.</p> <p>Nº modelo - _____</p> <p>Nº serie - _____</p> <p>Opciones de la máquina - _____</p> <p>Vendedor - _____</p> <p>Nº teléfono vendedor - _____</p> <p>Nº cliente - _____</p> <p>Fecha de instalación - _____</p>
-----------	---	---

FR	<p>COMMENT COMMANDER DES PIÈCES DÉTACHÉES – Voir le schéma ci-dessus.</p> <p>Utilisez uniquement des pièces fournies par la société TENNANT ou équivalentes. Les pièces et fournitures peuvent être commandées en ligne, par téléphone, fax, ou par courrier.</p> <p>Suivez les étapes ci-dessous pour assurer une livraison rapide.</p> <ol style="list-style-type: none"> 1. (A) Identifiez le modèle de la machine. 2. (B) Identifiez le numéro de série de la machine, à partir de l'étiquette signalétique. 3. (C) Assurez-vous que le numéro de série correct est utilisé à partir de la liste de pièces détachées. 4. Identifiez le numéro de pièce et la quantité. Ne commandez pas par page ou numéros de référence. 5. Fournissez votre nom, le nom de votre société, votre numéro d'identification de client, l'adresse de facturation et d'expédition, le numéro de téléphone et le numéro du bon de commande. 6. Fournissez des instructions d'expédition détaillées. <hr/> <p>(D) ▽ - identifie un assemblage ▲ - identifie les pièces composant l'assemblage</p>	<p>A remplir au moment de l'installation à titre de référence.</p> <p>Nº du modèle - _____</p> <p>Nº de série - _____</p> <p>Options de la machine - _____</p> <p>Agent commercial - _____</p> <p>Nº tél. de l'agent commercial - _____</p> <p>Numéro d'identification client - _____</p> <p>Date d'installation - _____</p>
-----------	---	---

GENERAL RECOMMENDED MAINTENANCE

General Recommended Maintenance Items

Ref.	Part No.	Serial Number	Description	Qty.
	390942	(10000000-) Blade, Sqge, Rear, 37.50l Linatex[700mm]	1
▽	391384	(10000000-) Squeegee Kit, 700mm, Ure	1
▲	391377	(10000000-) Blade, Sqge, Front, 35.00l Ure [700mm]	1
▲	391378	(10000000-) Blade, Sqge, Rear, 37.50l Pyu [700mm]	1
▽	391386	(10000000-) Squeegee Kit, 700mm, Gum	1
▲	390943	(10000000-) Blade, Sqge, Front, 35.00l [Linx, 700mm]	1
▲	390936	(10000000-) Blade, Sqge, Rear, 37.50l Gum [700mm]	1
	86859	(10000000-) Squeegee Assy, Side [Linatex] (Disk Head - Standard)	2
	1058731	(10000000-) Squeegee Assy, Side, Disc, Ure (Disk Head - Optional)	2
	1058729	(10000000-) Squeegee Assy, Side, Disc, Gum (Disk Head - Optional)	2
	1073476	(10000000-) Caster, Swivel, 50mmd, M10 X 30, Clr PI	2
	1013531	(10000000-) Skirt, Spray, 650mm	1
	1010560	(10000000-) Wheel, Bmpr, 80d X 25w, Non-Marking	1
	1013611	(10000000-) Seal, Cover, Recvy	1
	1020719	(10000000-) Seal, Afmkt, Bulb, Clsd Cell, Adh, 8ft	1
	1020727	(10000000-) Seal, Afmkt, Bulb, Clsd Cell, Adh, 8ft	1
	1020301	(10000000-) Seal, Afmkt, Bulb, Clsd Cell, Adh, 8ft	1
	1014026	(10000000-) Hose, Vacuum, 1.50id X 057.1l, 2cuff,Blk	1
	370114	(10000000-) Filter Kit, Vacfan	1
	1016392	(10000000-) Gasket, Fltr, Tank	1
▽	1014274	(10000000-) Hose Assy, Drain, 1.50id X 27.8l, Blk (Recovery Tank)	1
▲▽	1008639	(10000000-) Cap, Drain Assembly	1
▲▲	1019563	(10000000-) Strap, Drain Cap	1
▲▲	1008637	(10000000-) O Ring, 1.48" Id, 1.76" Od	1
▽	1014268	(10000000-) Hose Assy, Drain, 1.50id X 27.0l, Blk (Solution Tank)	1
▲▽	1008639	(10000000-) Cap, Drain Assembly	1
▲▲	1019563	(10000000-) Strap, Drain Cap	1
▲▲	1008637	(10000000-) O Ring, 1.48" Id, 1.76" Od	1
▽	1240354	(10000000-) Switch, Key	1
▲	1240918	(10000000-) Key, Switch	1
	1030592	(10000000-) Seal, Afmkt, Bulb, 90, 0.75d F/11ga 03ft	1
	1052726	(10000000-) Alarm, 9-48vdc, 95 Db(A) [Ec-H20]	1
	9013646	(10000000-) Cartridge, Ec-H2o Nanoclean Wcm, 270ml	1
	9011810	(10000000-) Module Kit, Replmt [Ec-H2o, B 02] (See Breakdowns)	1
	1216973	(10000000-) Pump Assy, Dispenser	1
	1014918	(10000000-) Wheel, 03.oD 0.88W 0.31B, W/ Bshg, Rbr	1
	1242894	(10000000-) Sign Kit, Amr [Home Location]	1

SECTION 2

Contents	Page
Fig. 1 – Replacement Brushes And Pad Drivers, 650 mm (26 in)	2-2
Fig. 2 – Main Frame and Rear Wheels Group ...	2-4
Fig. 3 – Front Guard Group	2-6
Fig. 4 – Seat Group	2-8
Fig. 5 – Steering Group	2-10
Fig. 6 – Instrument Panel Group	2-12
Fig. 7 – Front Covers Group	2-14
Fig. 8 – Front Drive Wheel Group	2-16
Fig. 9 – Brake and Accelerator Pedals Group ..	2-18
Fig. 10 – Disk Scrub Head Lift Group	2-20
Fig. 11 – Disk Scrub Head Drive Motor Group, 650 mm (26 in)	2-22
Fig. 12 – Disk Scrub Head Side Squeegee Group, Right	2-24
Fig. 13 – Disk Scrub Head Side Squeegee Group, Left	2-26
Fig. 14 – Recovery Tank Group	2-28
Fig. 15 – Recovery Tank Cover and Lights Group	2-30
Fig. 16 – Vacuum Fan Group	2-32
Fig. 17 – Solution Tank Group, Disk Scrub Head	2-34
Fig. 18 – Tanks Drain Group	2-36
Fig. 19 – Battery Group	2-38
Fig. 20 – Rear Squeegee Lift Group, Disk Scrub Head	2-40
Fig. 21 – Rear Squeegee Group, 650 mm (26 in)	2-42
Fig. 22 – Front Camera and Sensors Group	2-44
Fig. 23 – Electrical Controller Group	2-46
Fig. 24 – Electrical Group	2-48
Fig. 25 – Electrical Schematic	2-50
Fig. 26 – Wire Harnesses Group	2-55
Fig. 27 – Label Group	2-63

Fig. 1 – Replacement Brushes And Pad Drivers, 650 mm (26 in)

	Ref.	Part No.	Serial Number	Description	Qty.
▽	1	1220226	(10000000–) Brush Assy, Disk, Scb, 13.0d, Nylon	2
▲	2	9014664	(10000000–) Brush Kit, Hub Assy, Drive, Ci [Hdpe]	1
▽	1	1220223	(10000000–) Brush Assy, Disk, Scb, 13.0d, Polypropylene	2
▲	2	9014664	(10000000–) Brush Kit, Hub Assy, Drive, Ci [Hdpe]	1
▽	1	1220228	(10000000–) Brush Assy, Disk, Scb, 13.0d, Super Abrasive	2
▲	2	9014664	(10000000–) Brush Kit, Hub Assy, Drive, Ci [Hdpe]	1
▽	3	1220243	(10000000–) Driver Assy, Pad, 13.0d	2
▲	4	9014664	(10000000–) Brush Kit, Hub Assy, Drive, Ci [Hdpe]	1
▲	5	1016063	(10000000–) Disk, Driver, Pad, W/ Face, 13.0d	1
▲	6	370095	(10000000–) Device, Centering, Clip On, TI [Gf Pp]	1
▲	7	360943	(10000000–) Screw, Pan, Phl, 10–14 X 0.75, F/ Plstc	3
	8	89046	(10000000–) Pad, Stripping, 13.0d, Brown[1pick=1pad]	2
	8	89047	(10000000–) Pad, Scrubbing, 13.0d, Blu	2
	8	89048	(10000000–) Pad, Buff, 13.0d, Red [1pick=1pad]	2
	8	89049	(10000000–) Pad, Polish, 13.0d, White [1pick=1pad]	2
	8	1051024	(10000000–) Pad, Surf Prep, 13.0d [Mar, 1pick=1pad]	2

▽ Assembly

▲ Included in Assembly

Fig. 2 - Main Frame and Rear Wheels Group

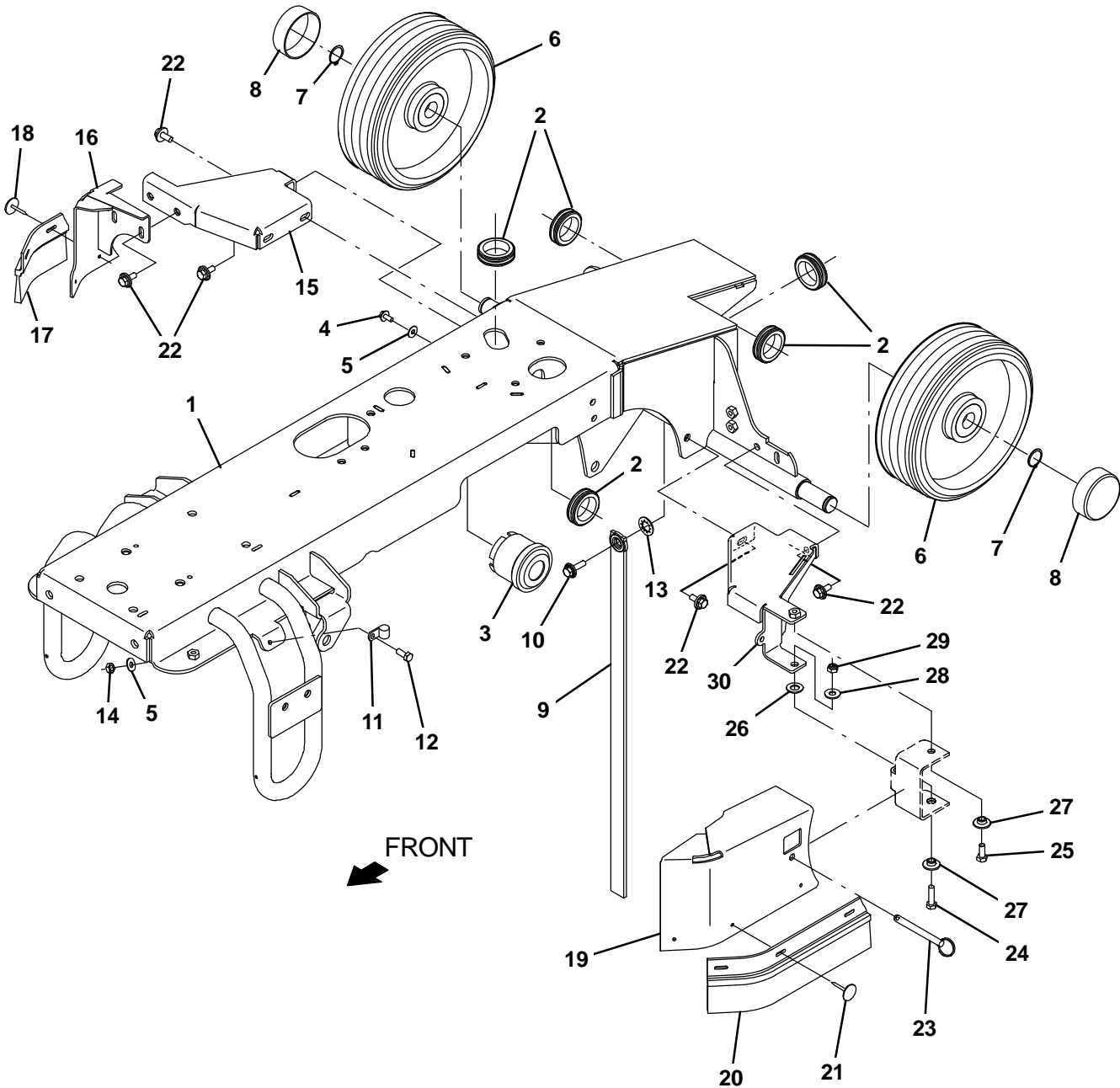

Fig. 2 – Main Frame and Rear Wheels Group

Ref.	Part No.	Serial Number	Description	Qty.
1	1240499	(10000000–) Frame Wldt, Main, Disk	1
2	10632–13	(10000000–) Grommet, Rbr, 1.50id, F/1.8h, .19 Matl	5
3	1018505	(10000000–) Horn, 12–48vdc [88.5 Decibels]	1
4	1034731	(10000000–) Screw, Hex, M6 X 1.00 X 16, Sems, Ss	1
5	01684	(10000000–) Washer, Flat, 0.27b 0.69d .05, Ss	2
6	1038560	(10000000–) Tire Assy, Solid, 250mm X 80mm, 25mmid	2
7	09005	(10000000–) Ring, Retaining, Ext, 1.00d, Basic	2
8	1016957	(10000000–) Cap, Vyl, 70mmid X 25mml	2
9	71579	(10000000–) Strap, Static, W/Grommet, .19 1.1W 25.0L	1
10	1072628	(10000000–) Screw, Hex, M8 X 1.25 X 25, Sems	1
11	26395–1	(10000000–) Clamp, Cable, Stl, 0.56d X 0.38w, 1hole	1
12	08716	(10000000–) Screw, Hex, M6 X 1.00 X 20, Ss	1
13	41141	(10000000–) Washer, lock, Int–Ext, 0.31	1
14	08712	(10000000–) Nut, Hex, Lock, M6 X 1.00, NI, Ss	1
15	1242192	(10000000–) Bracket Wldt, Guard, Rear, Rh	1
16	1241362	(10000000–) Plate, Guard, Rear, Rh	1
▽	9018619	(10000000–) Bristles Kit, Guard, Rh	1
▲	17 1239809	(10000000–) Bristles, Guard, Rear, Rh	1
▲	18 378770	(10000000–) Plug, Hole, Rnd, 0.28h 1.5l, Brb, Blk	2
19	1241370	(10000000–) Guard Wldt, Rear, Lh	1
▽	9018618	(10000000–) Bristles, Guard, Rear, Lh	1
▲	20 1239807	(10000000–) Bristles, Guard, Rear, Lh	1
▲	21 378770	(10000000–) Plug, Hole, Rnd, 0.28h 1.5l, Brb, Blk	3
22	1020341	(10000000–) Screw, Hex, M8 X 1.25 X 20, Ss, Sems	7
23	369359	(10000000–) Pin, Hitch, .375d X 3.12l, PI	1
24	09011	(10000000–) Screw, Hex, M8 X 1.25 X 30, Ss	1
25	12273	(10000000–) Screw, Hex, m8 X 1.25 X 20, NI, Ss	1
26	608562	(10000000–) Washer, Flat, 0.51b 0.94d .06, Nyl	1
27	80950	(10000000–) Bushing, Flng, 0.32b 0.50d 0.24l, Bnz	2
28	01685	(10000000–) Washer, Flat, 0.38B 0.88D .08, Ss	1
29	08713	(10000000–) Nut, Hex, Lock, M8 X 1.25, NI, Ss	1
30	1242193	(10000000–) Bracket Wldt, Guard, Rear, Lh	1

▽ Assembly

▲ Included in Assembly

Fig. 3 - Front Guard Group

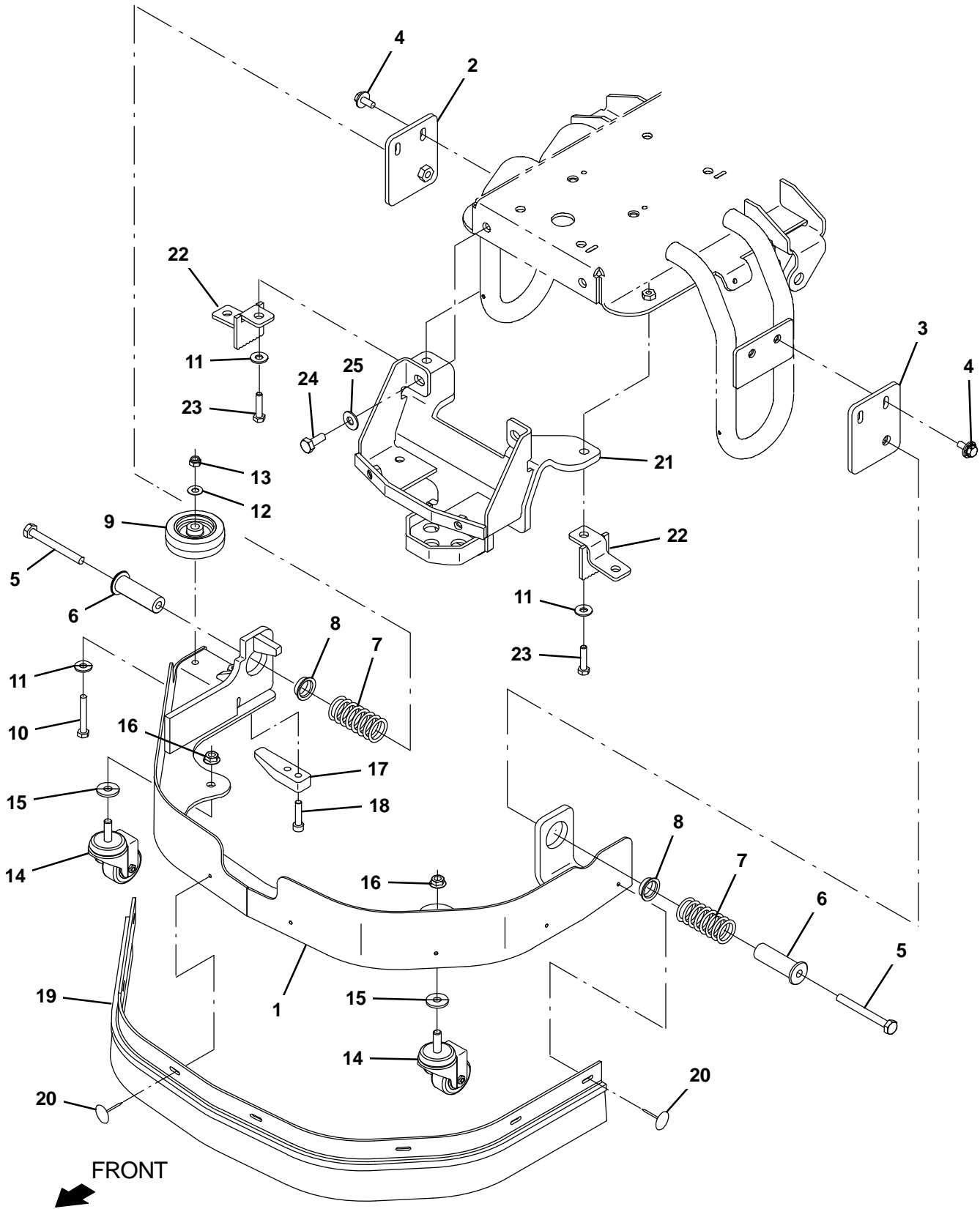

Fig. 3 – Front Guard Group

Ref.	Part No.	Serial Number	Description	Qty.
1	1241107	(10000000–) Guard Wldt, Front	1
2	1241309	(10000000–) Plate Wldt, Guard, Pivot, Rh	1
3	1241311	(10000000–) Plate Wldt, Guard, Pivot, Lh	1
4	1020341	(10000000–) Screw, Hex, M8 X 1.25 X 20, Ss, Sems	4
5	09746	(10000000–) Screw, Hex, M10 X 1.50 X 90, Ss	2
6	1241213	(10000000–) Sleeve, Flng, 0.40b 1.00/0.63d 0.63l, Ss	2
7	1241545	(10000000–) Spring, Cmpr, 1.22od .15wir 2.0l	2
8	1037827	(10000000–) Bushing, Flng, 0.87b 1.25d 0.38l	2
9	1014918	(10000000–) Wheel, 03.0d 0.88w 0.31b, W/ Bshg, Rbr	1
10	222504	(10000000–) Screw, Hex, M8 X 1.25 X 55, Ss	1
11	01685	(10000000–) Washer, Flat, 0.38b 0.88d .08, Ss	3
12	140027	(10000000–) Washer, Flat, 0.35b 0.75d .04, Ss	1
13	08713	(10000000–) Nut, Hex, Lock, M8 X 1.25, NI, Ss	1
14	1073476	(10000000–) Caster, Swivel, 50mmd, M10 X 30, Clr PI	2
15	1014563	(10000000–) Washer, Flat, 0.40b 1.12d .12, Ss	2
16	07792	(10000000–) Nut, Hex, Flng, M10 X 1.50	2
17	1242373	(10000000–) Block, Guard	1
18	41445	(10000000–) Screw, Soc, M8 X 1.25 X 35, 12.9	1
▽	9018620	(10000000–) Bristles kit, Guard, Front	1
▲	1241112	(10000000–) Bristles, Guard, Front	1
▲	378770	(10000000–) Plug, Hole, Rnd, 0.28h 1.5l, Brb, Blk	7
21	1241413	(10000000–) Guard Wldt, Sensor	1
22	1241167	(10000000–) Bracket Wldt, Tank, Solution	2
23	59658	(10000000–) Screw, Hex, M8 X 1.25 X 35, NI, Ss	2
24	09028	(10000000–) Screw, Hex, M10 X 1.50 X 25, Ss	2
25	01686	(10000000–) Washer, Flat, 0.44b 1.00d .08, Ss	2

▽ Assembly

▲ Included in Assembly

Fig. 4 - Seat Group

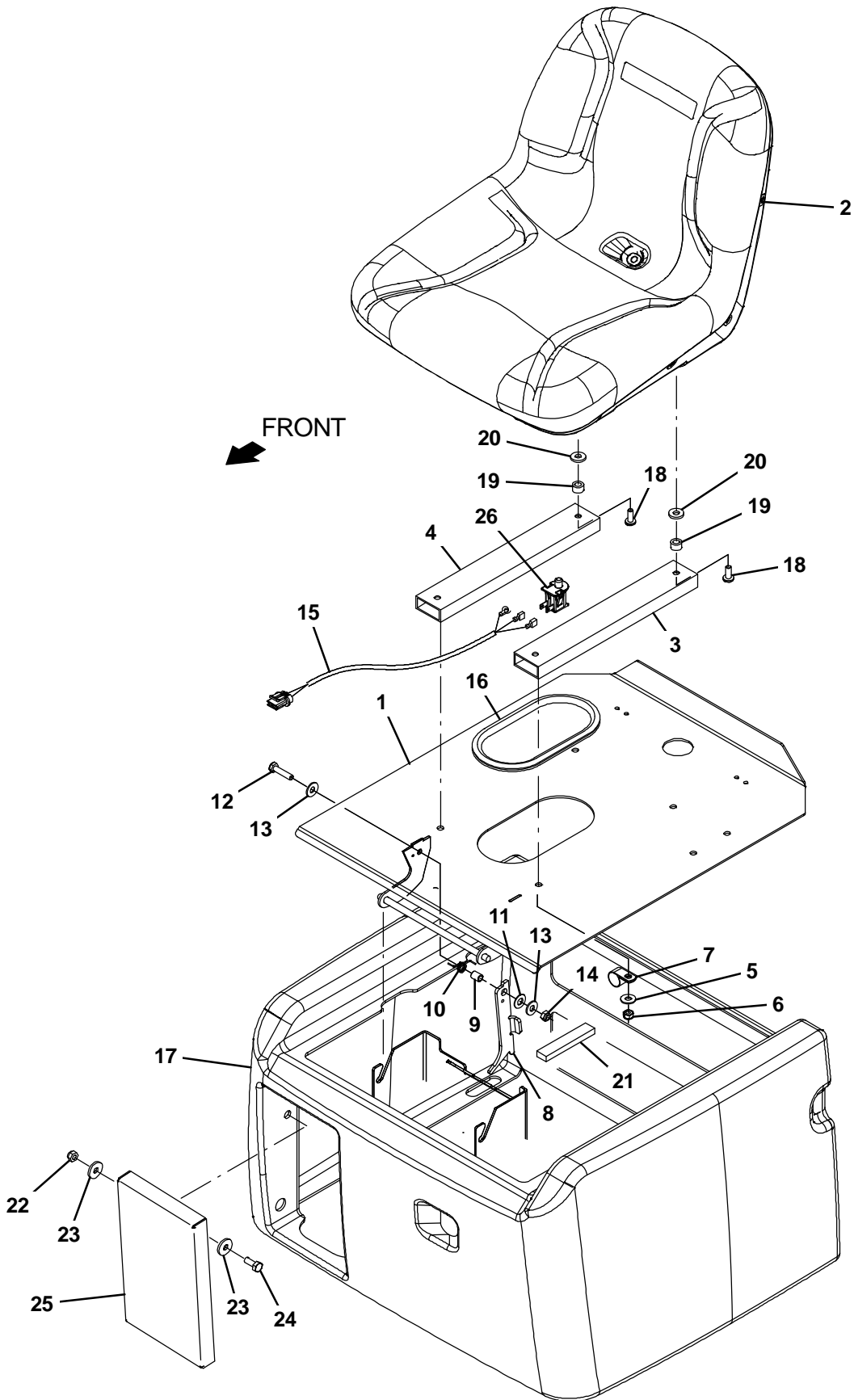

Fig. 4 – Seat Group

Ref.	Part No.	Serial Number	Description	Qty.
1	9018590	(10000000–) Plate, Seat, W/ Labels	1
1	9018591	(10000000–) Plate, Seat, W/ Labels, Tj (Japan Only)	1
2	9005082	(10000000–) Seat Kit, Std, Replmt	1
3	1017054	(10000000–) Rail, Adj, Slide, Seat, 11.5l, W/ Latch	1
4	1017053	(10000000–) Rail, Adj, Slide, Seat, 11.5l	1
5	32491	(10000000–) Washer, Flat, 0.31, Std	4
6	01760	(10000000–) Nut, Hex, Lock, .31–18, NI, Thin	4
7	46236	(10000000–) Clamp, Cable, Stl, 0.25d X 0.56w, 1hole	1
8	1241507	(10000000–) Plate, Stop, Seat	1
9	1017699	(10000000–) Sleeve, P/M, 0.32b 0.44d 0.6l [430ss]	1
10	10928	(10000000–) Spring, Tors, 0.49id .05wir 05.0coil	1
11	1018151	(10000000–) Washer, Flat, 0.44b 0.88d .06, Nyl	1
12	09023	(10000000–) Screw, Hex, M8 X 1.25 X 35, FI, Ss	1
13	01685	(10000000–) Washer, Flat, 0.38b 0.88d .08, Ss	2
14	08713	(10000000–) Nut, Hex, Lock, M8 X 1.25, NI, Ss	1
15	391951	(10000000–) Harness, Seat [T7/Ssr]	1
16	1020170	(10000000–) Molding, Afmkt, Trim, Pvc, .08 .11, 02ft	1
17	9018603	(10000000–) Cover, Box, Battery, TI, Afmkt, [T7Amr]	1
18	76956	(10000000–) Screw, Hex, .31–18 X 1.25, G5	4
19	1051052	(10000000–) Spacer, Rnd, .38b .88d .38l	4
20	69461	(10000000–) Washer, Flat, 0.38b 0.88d .12, Stl, PI	4
21	1046428	(10000000–) Seal, Afmkt, Rbr, Clsd, Adh, 02ft	1
22	08713	(10000000–) Nut, Hex, Lock, M8 X 1.25, NI, Ss	2
23	1017218	(10000000–) Washer, Flat, 0.32b 1.00d .12, Ss	4
24	09740	(10000000–) Screw, Hex, M8 X 1.25 X 20, Ss	2
25	1051138	(10000000–) Bracket, Cover, Fast Open [T7 Ec–H2o]	1
26	1048955	(10000000–) Switch, Seat, No [Delta 6440–04]	1

Fig. 5 - Steering Group

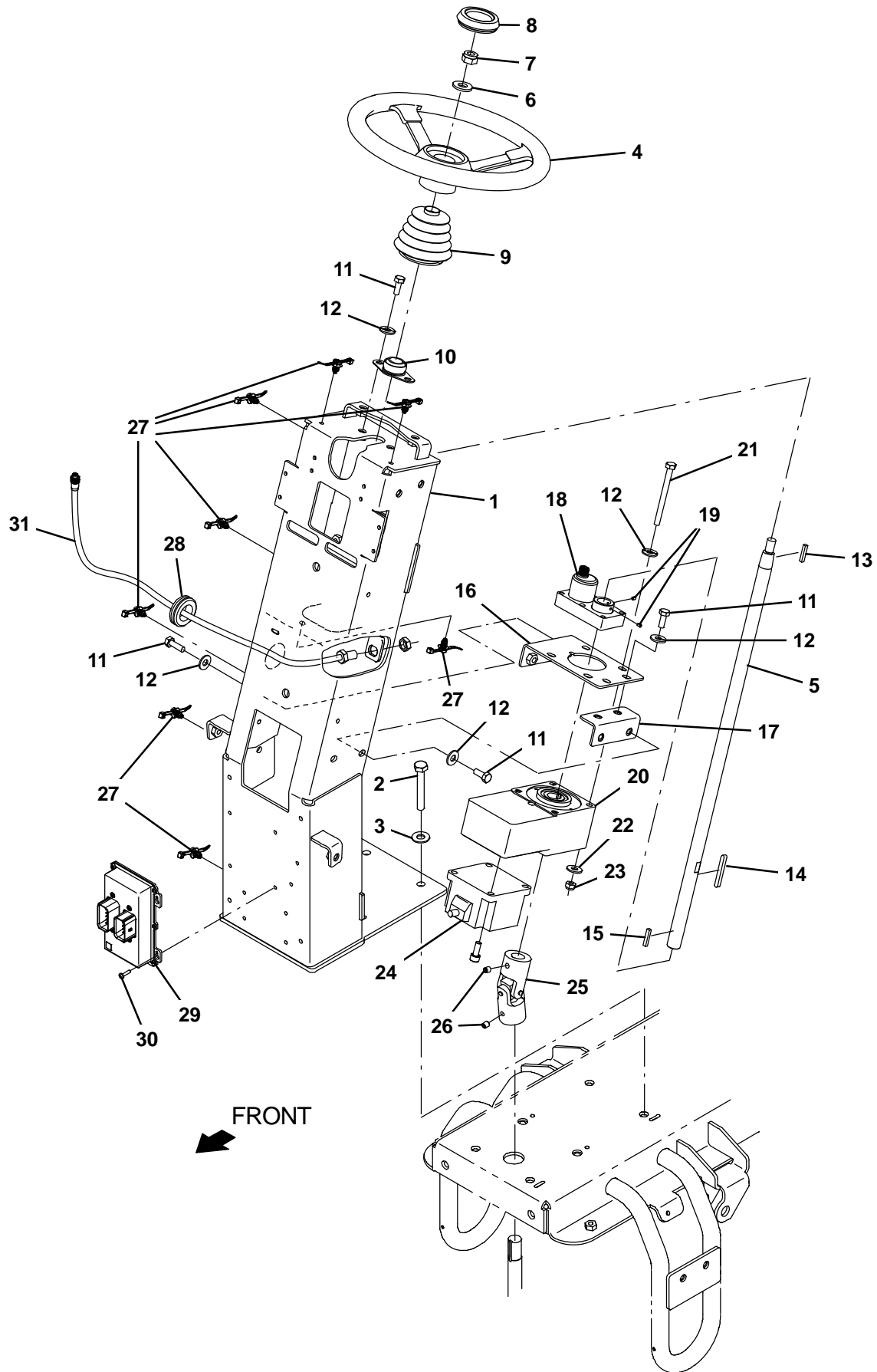

Fig. 5 – Steering Group

Ref.	Part No.	Serial Number	Description	Qty.
1	1241149	(10000000–) Column Wldt, Steering	1
2	14529	(10000000–) Screw, Hex, M10 X 1.50 X 70, Ss	4
3	01686	(10000000–) Washer, Flat, 0.44b 1.00d .08, Ss	4
4	1012002	(10000000–) Wheel, Steering, 300mm	1
5	1240109	(10000000–) Shaft, Steering	1
6	64154	(10000000–) Washer, Flat, 0.53b 1.12d .11, Stl, Pl	1
7	08711	(10000000–) Nut, Hex, Lock, M12 X 1.75, NI	1
8	1019706	(10000000–) Cap, Wheel, Steering	1
9	1012437	(10000000–) Bellows, Shaft, Steering	1
10	223065	(10000000–) Bearing, Flng, 2hole, 0.75b [Nyl]	1
11	09740	(10000000–) Screw, Hex, M8 X 1.25 X 20, Ss	8
12	01685	(10000000–) Washer, Flat, 0.38b 0.88d .08, Ss	12
13	1014328	(10000000–) Key, Sq, 05mm X 05mm, 25mml	1
14	1242289	(10000000–) Key, Sq, 06mm X 06mm, 50mml	1
15	00912	(10000000–) Key, Sq, 0.19 X 0.19, 1.00l	1
16	1241160	(10000000–) Plate Wldt, Motor, Steering	1
17	1241157	(10000000–) Plate Wldt, Motor, Steering	1
18	9018592*	(10000000–) Sensor, Position, Steering, Afmkt	1
19	1240459	(10000000–) Screw, Set, M4 X 0.70 X 6, NI	2
20	1240007	(10000000–) Gearbox, Steering, 20mmb	1
21	39281	(10000000–) Screw, Hex, M8 X 1.25 X 90, 8.8	4
22	32491	(10000000–) Washer, Flat, 0.31, Std	4
23	08713	(10000000–) Nut, Hex, Lock, M8 X 1.25, NI, Ss	4
24	1242348	(10000000–) Motor Assy, Steering, Rwk	1
25	1242308	(10000000–) Joint, U, 0.75id [Rework]	1
26	46820	(10000000–) Screw, Set, .31–18 X 0.38, NI	2
27	1210807	(10000000–) Wire, Tie [W/.25" Fir Tree Clip]	8
28	10632	(10000000–) Grommet, Rbr, 0.89id, F/1.2h, .14 Matl	1
29	9018593*	(10000000–) Amplifier, Cntrl, Motor, Afmkt	1
30	24265	(10000000–) Screw, Pan, Phl, M4 X 0.70 X 16, Ss	4
31	1242301	(10000000–) Cable, Service Amr	1

* Requires Tennant *True* service or an authorized Tennant service provider.

Fig. 6 - Instrument Panel Group

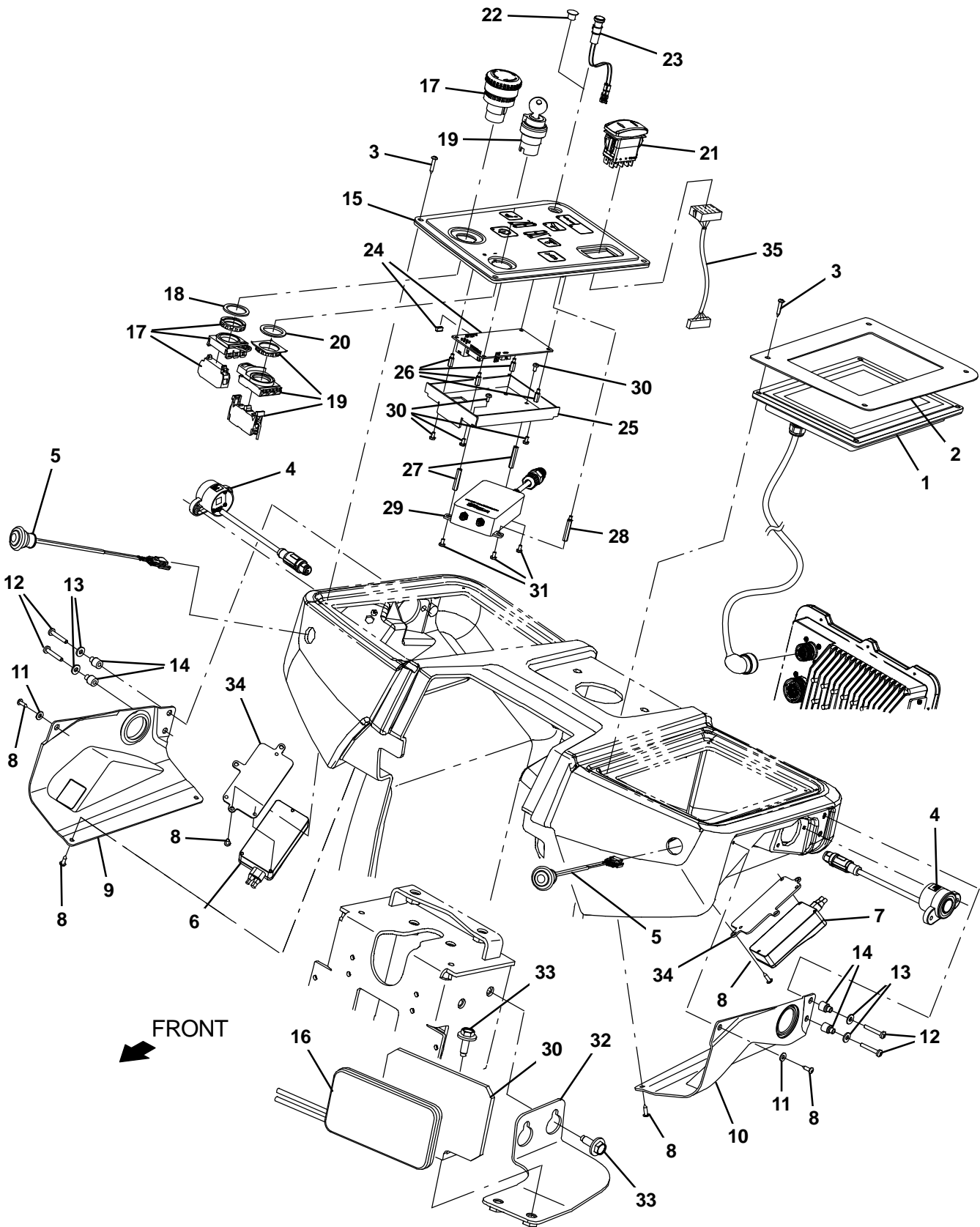

Fig. 6 – Instrument Panel Group

Ref.	Part No.	Serial Number	Description	Qty.
1	1240639	(10000000–) Monitor, Lcd, Touch	1
2	1241699	(10000000–) Plate, Bezel, Lcd	1
3	49162	(10000000–) Screw, Pan, Phl, 08–16 X 0.50, F/Plstc	8
4	9018608*	(10000000–) Camera, Amr, Afmkt [2D]	2
5	1240252	(10000000–) Light, Marker	2
6	9018594*	(10000000–) Camera, Amr, Side, Rh, Afmkt [Ifm 03X 3D]	1
7	9018595*	(10000000–) Camera, Amr, Side, Lh, Afmkt [Ifm 03X 3D]	1
8	140825	(10000000–) Screw, Pan, Phl, 06 X 0.50, Fmg/Ab, Blk	12
9	1241259	(10000000–) Bezel, Right	1
10	1241261	(10000000–) Bezel, Left	1
11	1035394	(10000000–) Washer, Flat, 0.17b 0.38d .04, Ss	2
12	04403	(10000000–) Screw, Pan, Phl, M4 X 0.70 X 25, NI, Ss	4
13	41579	(10000000–) Washer, Flat, 08, Ss	4
14	1242099	(10000000–) Sleeve, P/M, 0.17b 0.38d 0.54l	4
15	1242321	(10000000–) Panel Assy, Membrane	1
16	9018613*	(10000000–) Antenna, Amr, Afmkt	1
17	1242161	(10000000–) Switch, Safety, Shutoff	1
18	1242538	(10000000–) Ring, Lock, E–Stop	1
▽	19	1240354	(10000000–) Switch, Key	1
▲	1240918	(10000000–) Key, Switch	1
20	1241210	(10000000–) Ring, Lock, Switch	1
21	1240532	(10000000–) Switch, Rocker, Dpdt, Mom / None/ Mom	1
22	80061	(10000000–) Plug, Hole, Rnd, 0.30h 0.3l (W/O ec–H20 NanoClean)	1
23	1041822	(10000000–) Light, Led, .312d, 2 Volt [Tri–Color] (ec–H20 NanoClean)	1
▽	24	9018596*	(10000000–) Controller Kit, Membrane	1
▲	1244879	(10000000–) Shunt [Pcb, Jumper, .100" Spacing] (ec–H20 Only)	1
25	1240467	(10000000–) Cover, Circuitboard	1
26	1240633	(10000000–) Stand–Off, Hex, M3 X 0.5, M/F, 10mm	4
27	1240634	(10000000–) Stand–Off, Hex, M3 X 0.5, Fem, 25mm	2
28	1240907	(10000000–) Stand–Off, Hex, M3 X 0.5, F/M, 25mm	1
29	9018597*	(10000000–) Controller, Telem, Amr, Afmkt	1
30	1242513	(10000000–) Angle, Mtg, Antenna, 4g	1
31	06919	(10000000–) Screw, Pan, Phl, M3 X 0.50 X 6, 4.8	13
32	1242591	(10000000–) Bracket Wldt, Antenna	1
33	1037346	(10000000–) Screw, Hex, M8 X 1.25 X 25, 9.8, Sems	4
34	1241661	(10000000–) Plate, Mtg, Camera	2
35	1076463	(10000000–) Harness, Ele [T7Amr, Dir Switch]	1

* Requires Tennant *True* service or an authorized Tennant service provider.

▽ Assembly

▲ Included in Assembly

Fig. 7 - Front Covers Group

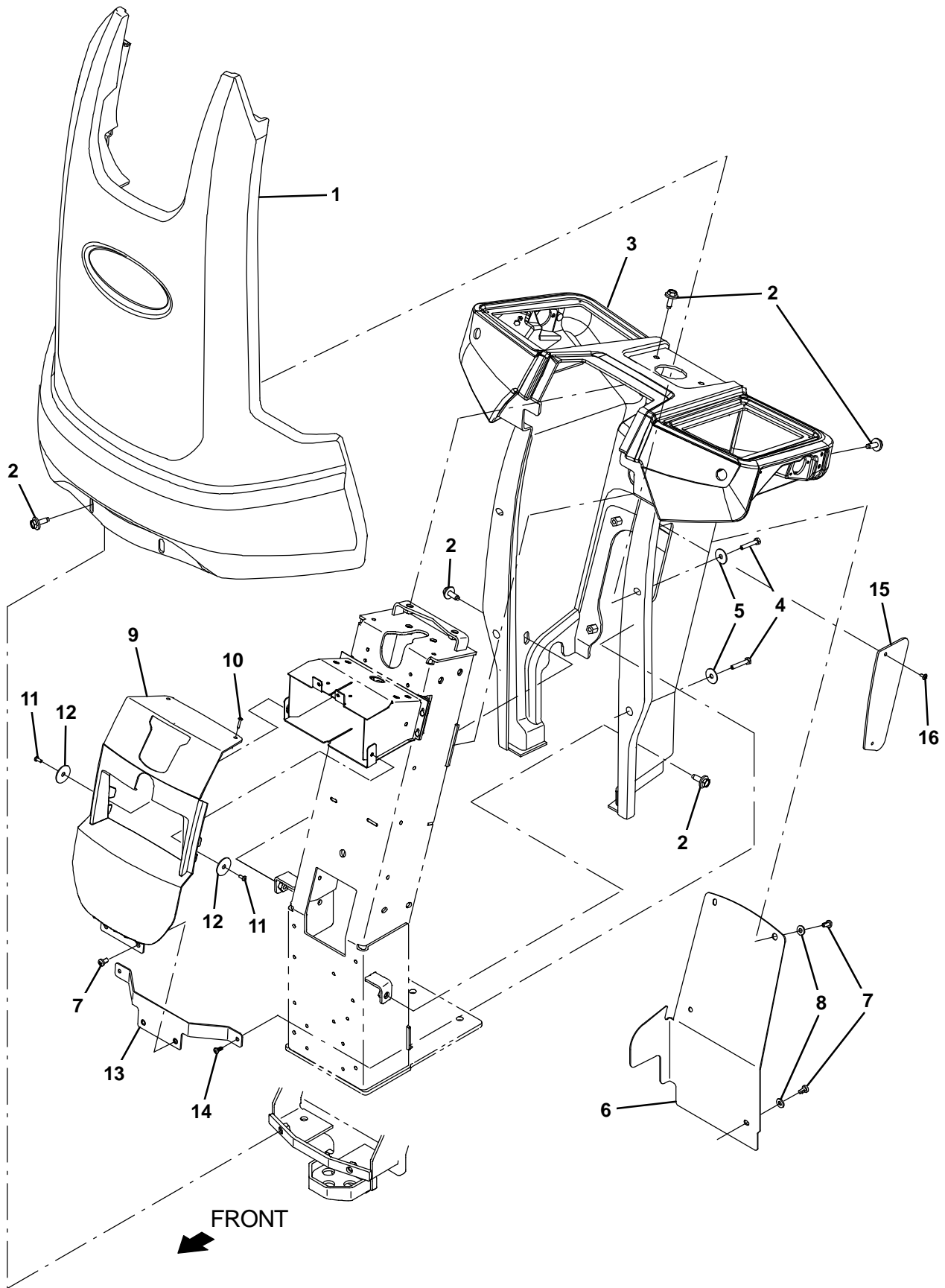

Fig. 7 – Front Covers Group

Ref.	Part No.	Serial Number	Description	Qty.
1	9018598	(10000000–) Shroud, Front, Rm–TI, Trimmed, W/Label	1
2	1037346	(10000000–) Screw, Hex, M8 X 1.25 X 25, 9.8, Sems	8
3	9018599*	(10000000–) Shroud, Instmt, Rm–TI, Trimmed, Afmkt	1
4	1242446	(10000000–) Screw, Hex, M6 X 1.00 X 35, 8.8, NI	4
5	397779	(10000000–) Washer, Flat, 0.28b 1.00d .06, Stl, Blk	4
6	1241353	(10000000–) Panel, Access, Column	1
7	1045525	(10000000–) Screw, Pan, Phl, M6 X 1.00 X 12, Blk	6
8	1069322	(10000000–) Washer, Flat, 0.25, Sae, Blk	4
9	9018600	(10000000–) Bezel, Cntr, W/Labels	1
10	1242443	(10000000–) Screw, Pan, Phl, 06 X 0.75, Fmg/Ab, Blk	2
11	49697	(10000000–) Screw, Pan, Phl, M4 X 0.70 X 10, Ss	2
12	41178	(10000000–) Washer, Flat, 0.25, Fendr	2
13	1241612	(10000000–) Bracket Wldt, Mtg, Bezel	1
14	1018155	(10000000–) Screw, Pan, Phl, M5 X 0.80 X 16, Tcut,Ss	2
15	1243967	(10000000–) Cover, Access, Controller	1
16	1014754	(10000000–) Screw, pan, Phl, M6 X 1.00 X 12, Blk	2

* Requires Tennant *True* service or an authorized Tennant service provider.

Fig. 8 - Front Drive Wheel Group

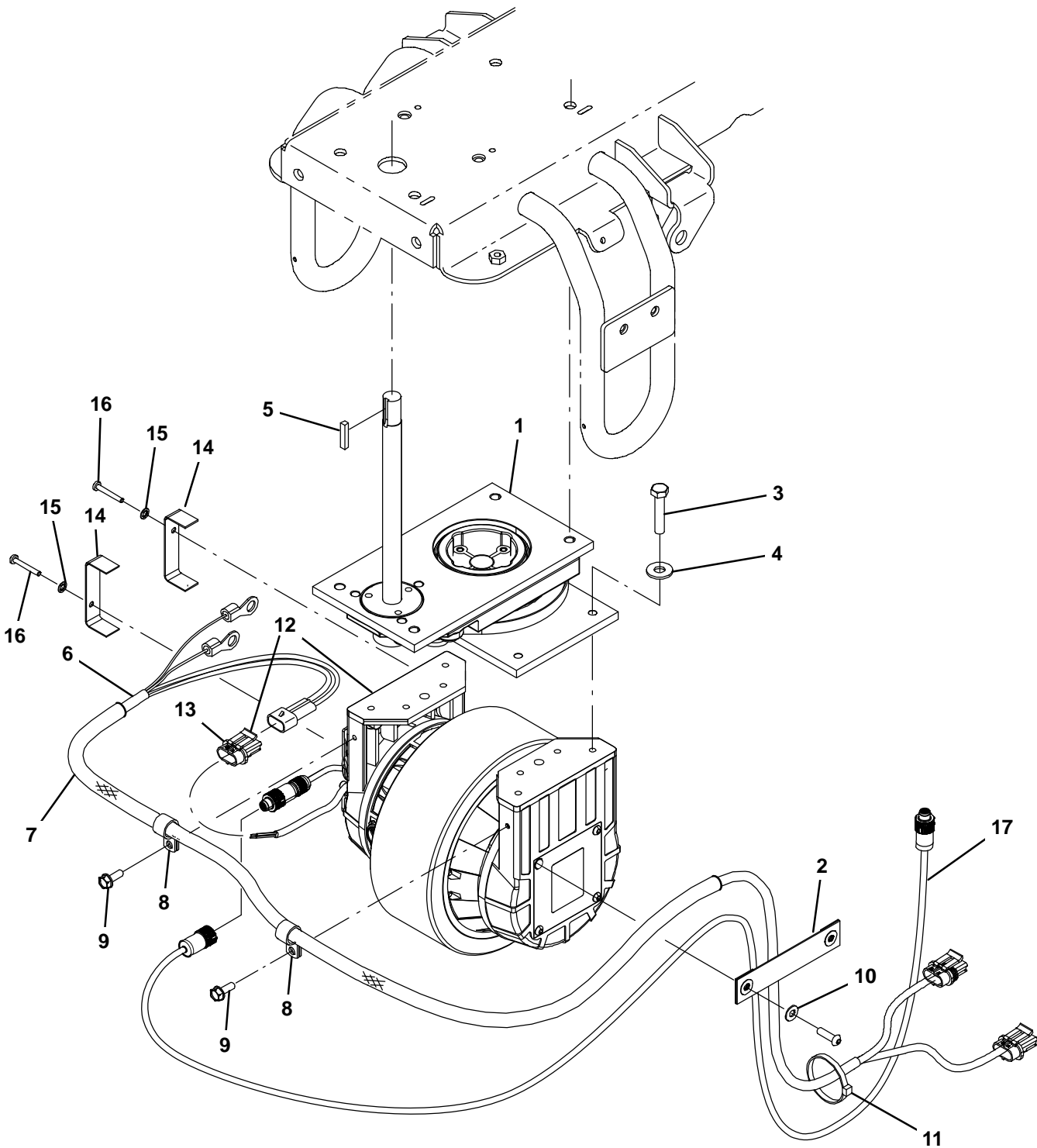

Fig. 8 – Front Drive Wheel Group

Ref.	Part No.	Serial Number	Description	Qty.	
1	1019724	(10000000–) Steer–Control Assy, Wheel Drive (See Breakdown)	1	
2	1019224	(10000000–) Strap, Nyl	1	
3	09010	(10000000–) Screw, Hex, M8 X 1.25 X 25, Ss	4	
4	01685	(10000000–) Washer, Flat, 0.31 Ss	4	
5	00912	(10000000–) Key, Sq, 0.19 X 0.19, 1.00l	1	
6	1065808	(10000000–) Harness, Motor, Brake [T7/Ssr]	1	
7	1015761	(10000000–) Sleeve, Afmkt, Nyl, 8.86ld, 03Ft	1	
8	140300	(10000000–) Clamp, Cable, Stl, 0.50d [Insulated]	2	
9	361339	(10000000–) Screw, Hex, M6 X 1.0 X 16, Fmg	2	
10	19066	(10000000–) Washer, Flat, #10	2	
11	130773	(10000000–) Tie, Cable, Nyl, 11.0l, .14w, 3.0 Max. D	4	
▽	12	9018601	(10000000–) Wheel, Drive, 250Mm, 24Vdc, W/Encd, Afmt	1
▲	13	1047186	(10000000–) Connector, Fem, 3 Recept [Mp630]	1
	14	1064972	(10000000–) Bracket, Cord	2
	15	02938	(10000000–) Washer, Lock, Int, 08, Ss	2
	16	33931	(10000000–) Screw, Pan, Phl, M4 X 0.70 X 30, Ss	2
	17	1242300	(10000000–) Cable, Sensor, Spd	2

▽ Assembly

▲ Included in Assembly

Fig. 9 – Brake and Accelerator Pedals Group

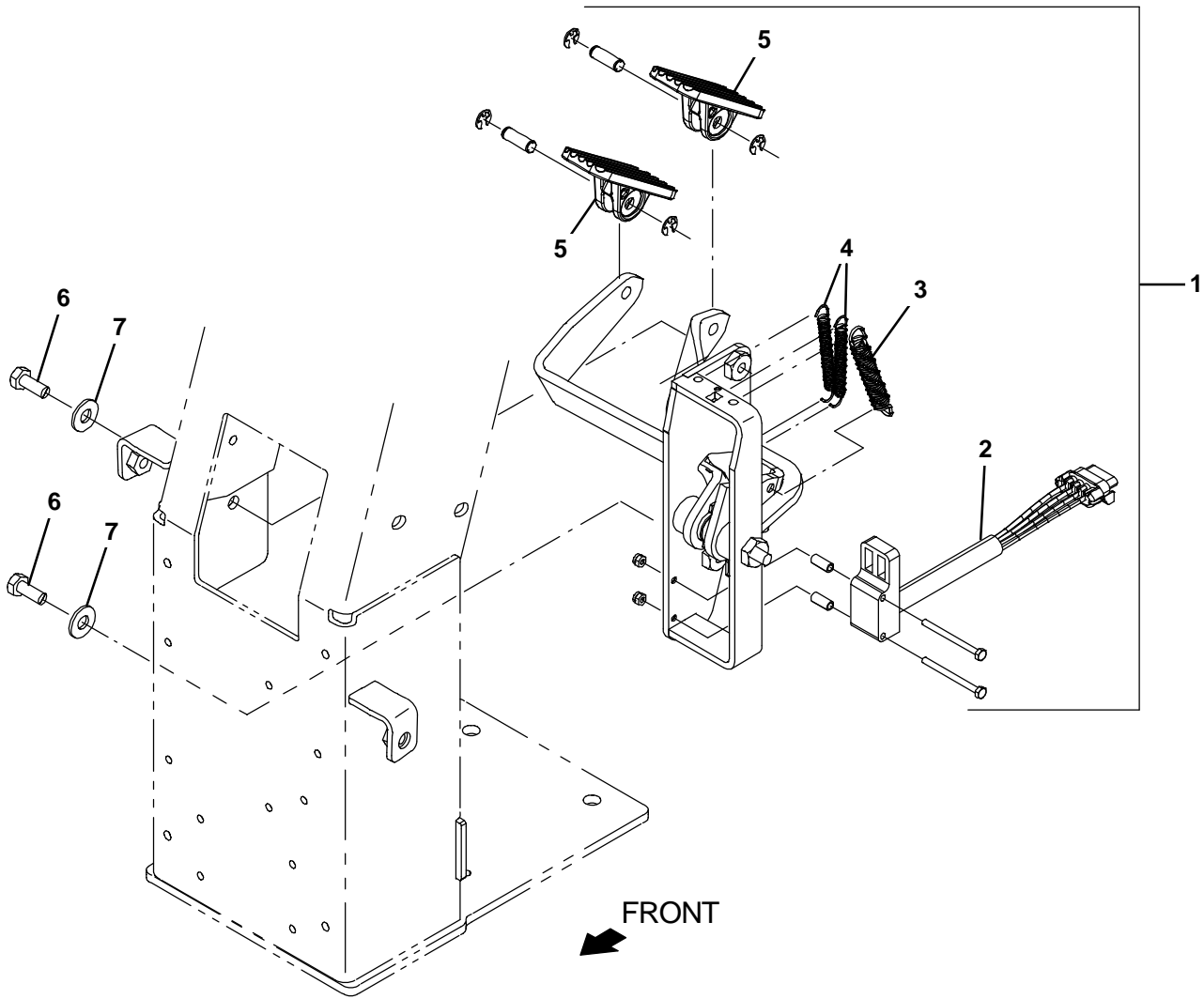

Fig. 9 – Brake and Accelerator Pedals Group

	Ref.	Part No.	Serial Number	Description	Qty.
▽	1	1072477	(10000000–) Pedal Assy, Accelerator, Brake	1
▲	2	1058687	(10000000–) Sensor, Position [Hall]	1
▲	3	1031716	(10000000–) Spring, Extn, 0.50od 0.07wir 03.0l	1
▲	4	1061049	(10000000–) Spring, Extn, 0.35od 0.05wir 02.8l	2
▲	5	1072478	(10000000–) Pedal, Foot, W/ Tread	2
	6	09740	(10000000–) Screw, Hex, M8 X 1.25 X 20, Ss	2
	7	01685	(10000000–) Washer, Flat, 0.38b 0.88d .08, Ss	2

▽ Assembly

▲ Included in Assembly

Fig. 10 - Disk Scrub Head Lift Group

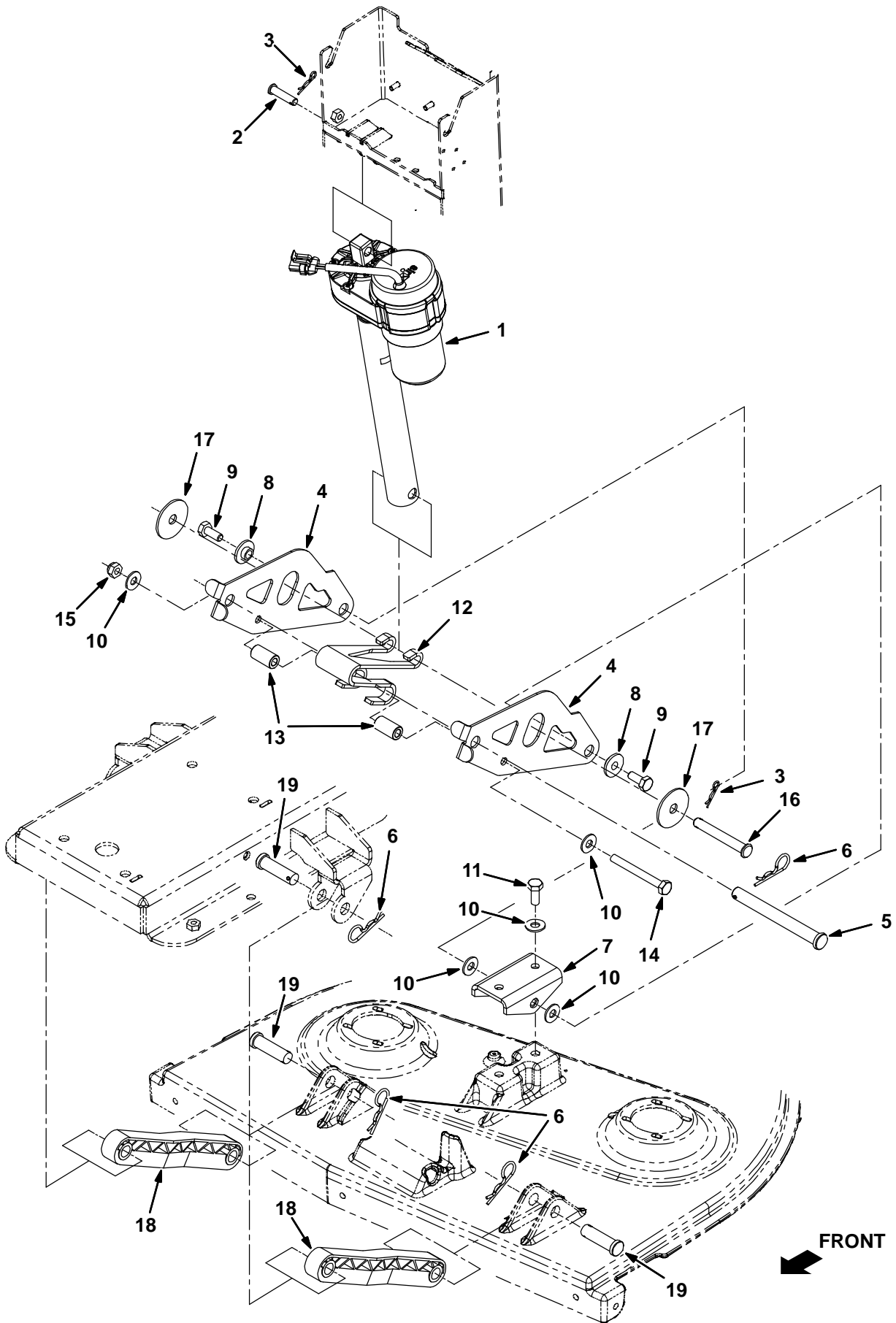

Fig. 10 – Disk Scrub Head Lift Group

Ref.	Part No.	Serial Number	Description	Qty.
1	1056622	(10000000-) Actuator, 24vdc, 04.5strk, 0600lb	1
2	1009356	(10000000-) Pin, Clevis , 10mm X 40l	1
3	86866	(10000000-) Pin, Hair Cotter, 0.38 D .072 Wir	2
4	1013278	(10000000-) Plate, Arm, Cntr, Lift, Scb Head	2
5	1010401	(10000000-) Pin, Clevis, 16d X 150l	1
6	02942	(10000000-) Pin, Hair Cotter, 0.62 D .120 Wir	5
7	1014076	(10000000-) Bracket, Lift	1
8	363087	(10000000-) Bushing, Flng, 0.44b 1.25d 0.25l	2
9	09770	(10000000-) Screw, Hex, M10 X 1.5 X 25, Ss, NI	2
10	01686	(10000000-) Washer, Flat, 0.44b 1.00 .08, Ss	6
11	09028	(10000000-) Screw, Hex, M10 X 1.5 X 25, Ss	2
12	1015413	(10000000-) Spring, Lift, Head, Scb	1
13	1013281	(10000000-) Sleeve, P/M, 18.5d 10.5b 34l 430 Ss	2
14	09746	(10000000-) Screw, Hex, M10 X 1.5 X 90, Ss	1
15	08714	(10000000-) Nut, Hex, Lock, M10 X 1.5, NI, Ss	1
16	1013356	(10000000-) Pin, Clevis, 12mm D X 90mm L	1
17	57048	(10000000-) Washer, Flat, 0.53b 2.13d .11, Stl, PI	2
18	222027	(10000000-) Arm, Lift, Head	2
19	222210	(10000000-) Pin, Clevis, 0.62 D X 2.12l	4

Fig. 11 – Disk Scrub Head Drive Motor Group, 650 mm (26 in)

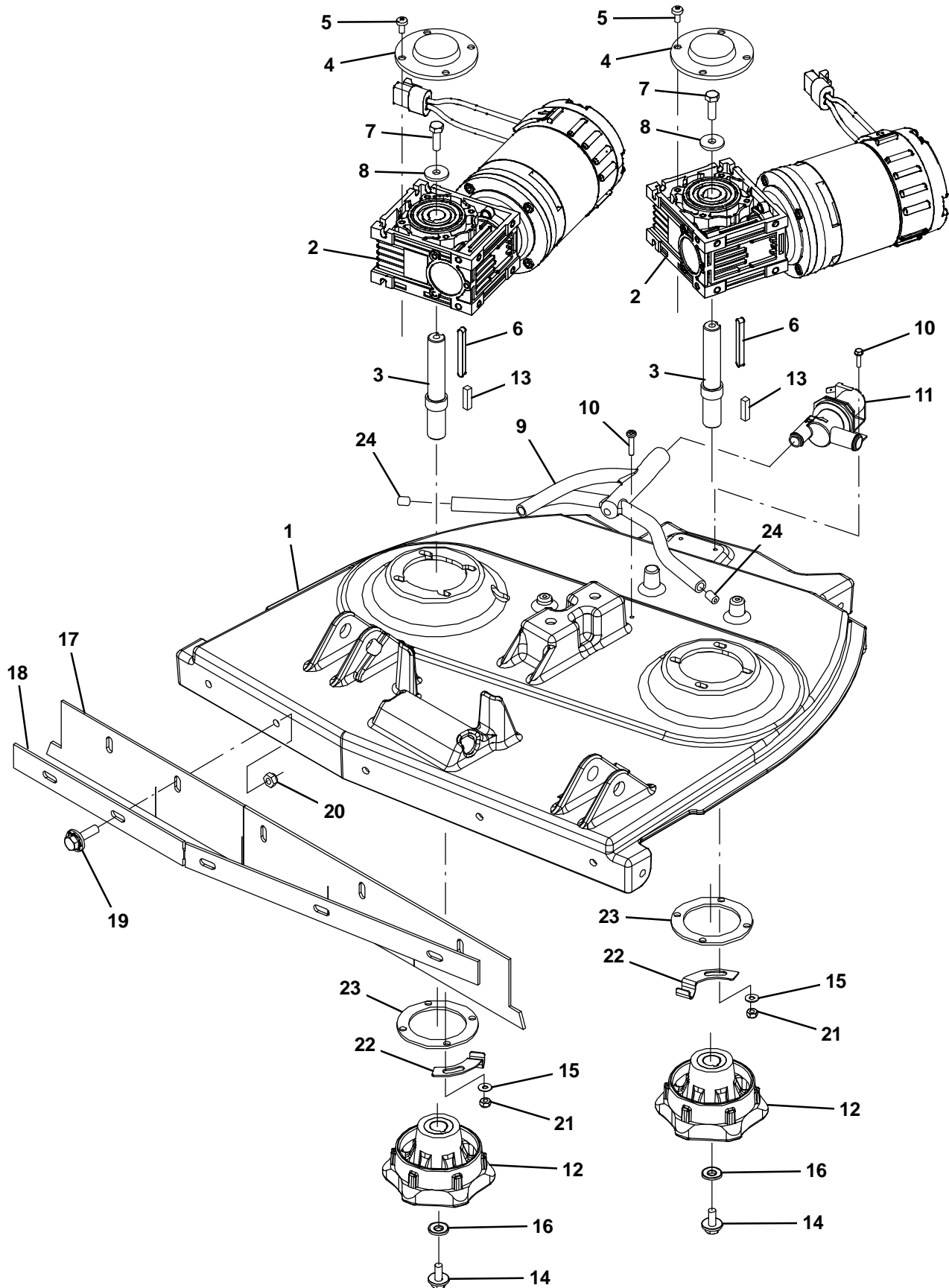

Fig. 11 – Disk Scrub Head Drive Motor Group, 650 mm (26 in)

Ref.	Part No.	Serial Number	Description	Qty.	
1	1013560	(10000000–) Head, Scb, 650mm	1	
▽	2	1210864	(10000000–) Motor, Ele, 24vdc 0260rpm	2
▲	372878	(10000000–) Brush Kit, Motor, Ele	1	
▲	372879	(10000000–) Hook, Safety	1	
▲	372880	(10000000–) Cover, Brush, Ele Motor	1	
▲	3	1212130	(10000000–) Shaft, Drive, Brush	1
▲	4	1212132	(10000000–) Cap, Motor	1
▲	5	363503	(10000000–) Screw, Pan, Phl, M6 X 1.00 X 12, Ss	4
▲	6	1212131	(10000000–) Key, Sq, 06mm X 06mm, 60mml	1
▲	7	09740	(10000000–) Screw, Hex, M8 X 1.25 X 20, Ss	1
▲	8	1017218	(10000000–) Washer, Flat, 0.32b 1.00d .12, Ss	1
	9	1014228	(10000000–) Manifold, Soltn, 650mm	1
	10	1016520	(10000000–) Screw, Hex, M4 X 0.7 16 Fmg, Ss	3
	11	1214973	(10000000–) Valve, Water, Solenoid, 24vdc, Bm10/Bm10	1
	12	1071636	(10000000–) Hub, Drive, Brush, Disk, 0.75b [6t]	2
	13	00928	(10000000–) Key, Sq, 0.25 X 0.25, 1.00l	2
	14	1020341	(10000000–) Screw, Hex, M8 X 1.25 X 20, Ss, Sems	2
	15	01684	(10000000–) Washer, Flat, 0.27b 0.69d .05, Ss (ec-H2O Model)	2
	16	1017218	(10000000–) Washer, Flat, 0.32b 1.00d .12, Ss	2
	17	1013531	(10000000–) Skirt, Spray, 650mm	1
	18	1013532	(10000000–) Retainer, Skirt, 650mm	1
	19	1072816	(10000000–) Screw, Hex, M8 X 1.25 X 30, Ss, Sems	5
	20	08713	(10000000–) Nut, Hex, Lock, M8 X 1.25, NI, Ss	5
	21	08712	(10000000–) Nut, Hex, Lock, M6 X 1.0, Ss, NI	8
	22	1052298	(10000000–) Bracket, Support, Hose [T7] (ec-H2O Model)	2
	23	1013821	(10000000–) Plate, Sppt	2
	24	1244729	(10000000–) Fitting, Plstc, Rst, .38OD/.19ld	2

▽ Assembly

▲ Included in Assembly

Fig. 12 - Disk Scrub Head Side Squeegee Group, Right

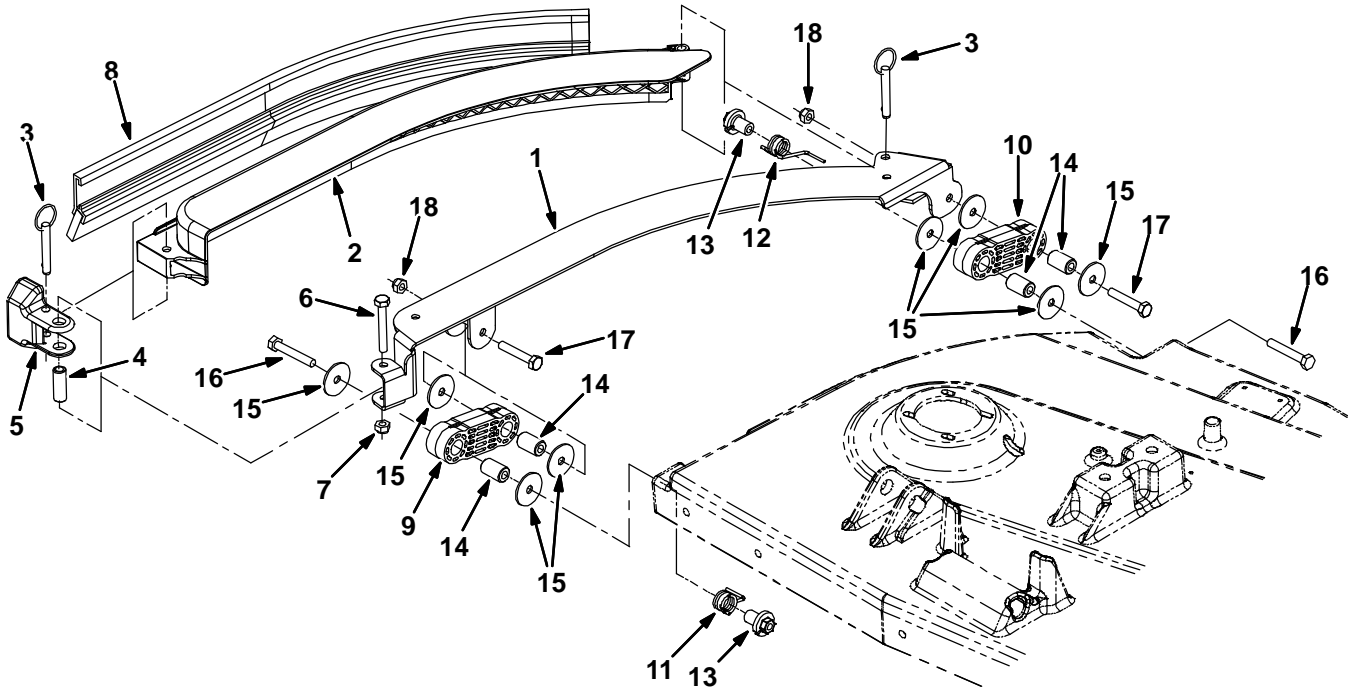

Fig. 12 – Disk Scrub Head Side Squeegee Group, Right

Ref.	Part No.	Serial Number	Description	Qty.
1	1017910	(10000000–) Support Wldt, Sqge, Rh	1
2	1017832	(10000000–) Retainer, Sqge, Rh	1
3	1015989	(10000000–) Pin, Hitch, .312d X 1.62l	2
4	1017495	(10000000–) Sleeve, P/M, 0.496d 0.318b 1.375 Ss	1
5	1017462	(10000000–) Block, Guard	1
6	222504	(10000000–) Screw, Hex, M8 X 1.25 X 55, Ss	1
7	08713	(10000000–) Nut, Hex, Lock, M8 X 1.25, NI, Ss	1
8	86859	(10000000–) Squeegee Assy, Side [Linatex] (Standard)	1
8	1058731	(10000000–) Squeegee Assy, Side, Disc, Ure (Optional)	1
8	1058729	(10000000–) Squeegee Assy, Side, Disc, Gum (Optional)	1
9	1010876	(10000000–) Link, Sqge	1
10	1017785	(10000000–) Link, Sqge	1
11	1011344	(10000000–) Spring, Tors	1
12	1011334	(10000000–) Spring, Tors	1
13	1011317	(10000000–) Retainer, Spring	2
14	1011717	(10000000–) Sleeve, P/M, 0.625d 0.318b 1.00 L 430ss	4
15	1011719	(10000000–) Washer, Flat, 0.33b 1.38d .075, Ss	8
16	49694	(10000000–) Screw, Hex, M8 X 1.25 X 50, Ss	2
17	222505	(10000000–) Screw, Hex, M8 X 1.25 X 45, Ss	2
18	08713	(10000000–) Nut, Hex, Lock, M8 X 1.25, NI, Ss	2

Fig. 13 – Disk Scrub Head Side Squeegee Group, Left

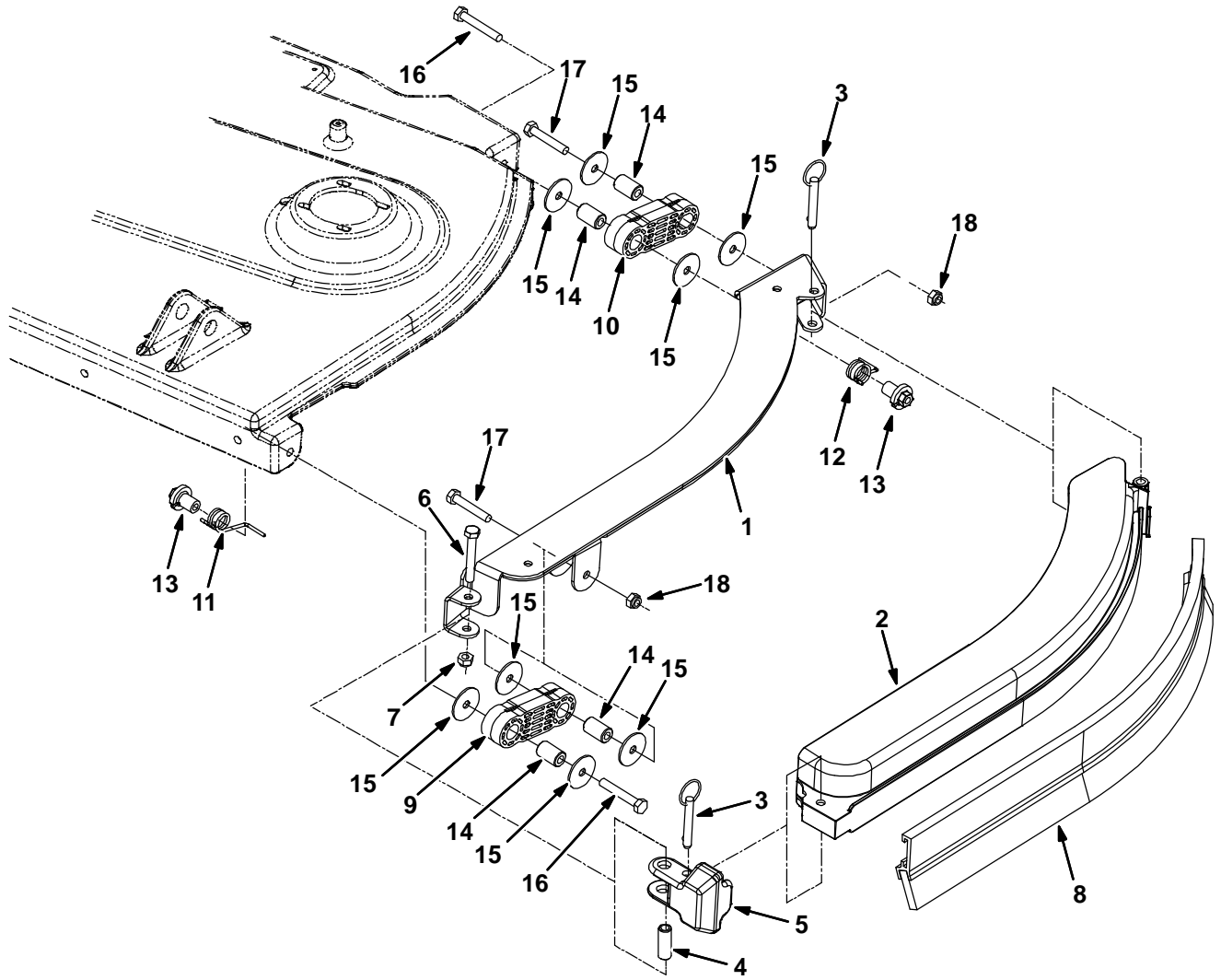

Fig. 13 – Disk Scrub Head Side Squeegee Group, Left

Ref.	Part No.	Serial Number	Description	Qty.
1	1017534	(10000000–) Support Wldt, Sqge, Lh	1
2	1017653	(10000000–) Retainer, Sqge, Lh	1
3	1015989	(10000000–) Pin, Hitch, .312d X 1.62l	2
4	1017495	(10000000–) Sleeve, P/M, 0.496d 0.318b 1.375 Ss	1
5	1017462	(10000000–) Block, Guard	1
6	222504	(10000000–) Screw, Hex, M8 X 1.25 X 55, Ss	1
7	08713	(10000000–) Nut, Hex, Lock, M8 X 1.25, NI, Ss	1
8	86859	(10000000–) Squeegee Assy, Side [Linatex] (Standard)	1
8	1058731	(10000000–) Squeegee Assy, Side, Disc, Ure (Optional)	1
8	1058729	(10000000–) Squeegee Assy, Side, Disc, Gum (Optional)	1
9	1010876	(10000000–) Link, Sqge	1
10	1017785	(10000000–) Link, Sqge	1
11	1011344	(10000000–) Spring, Tors	1
12	1011334	(10000000–) Spring, Tors	1
13	1011317	(10000000–) Retainer, Spring	2
14	1011717	(10000000–) Sleeve, P/M, 0.625d 0.318b 1.00 L 430ss	4
15	1011719	(10000000–) Washer, Flat, 0.33b 1.38d .075, Ss	8
16	49694	(10000000–) Screw, Hex, M8 X 1.25 X 50, Ss	2
17	222505	(10000000–) Screw, Hex, M8 X 1.25 X 45, Ss	2
18	08713	(10000000–) Nut, Hex, Lock, M8 X 1.25, NI, Ss	2

Fig. 14 – Recovery Tank Group

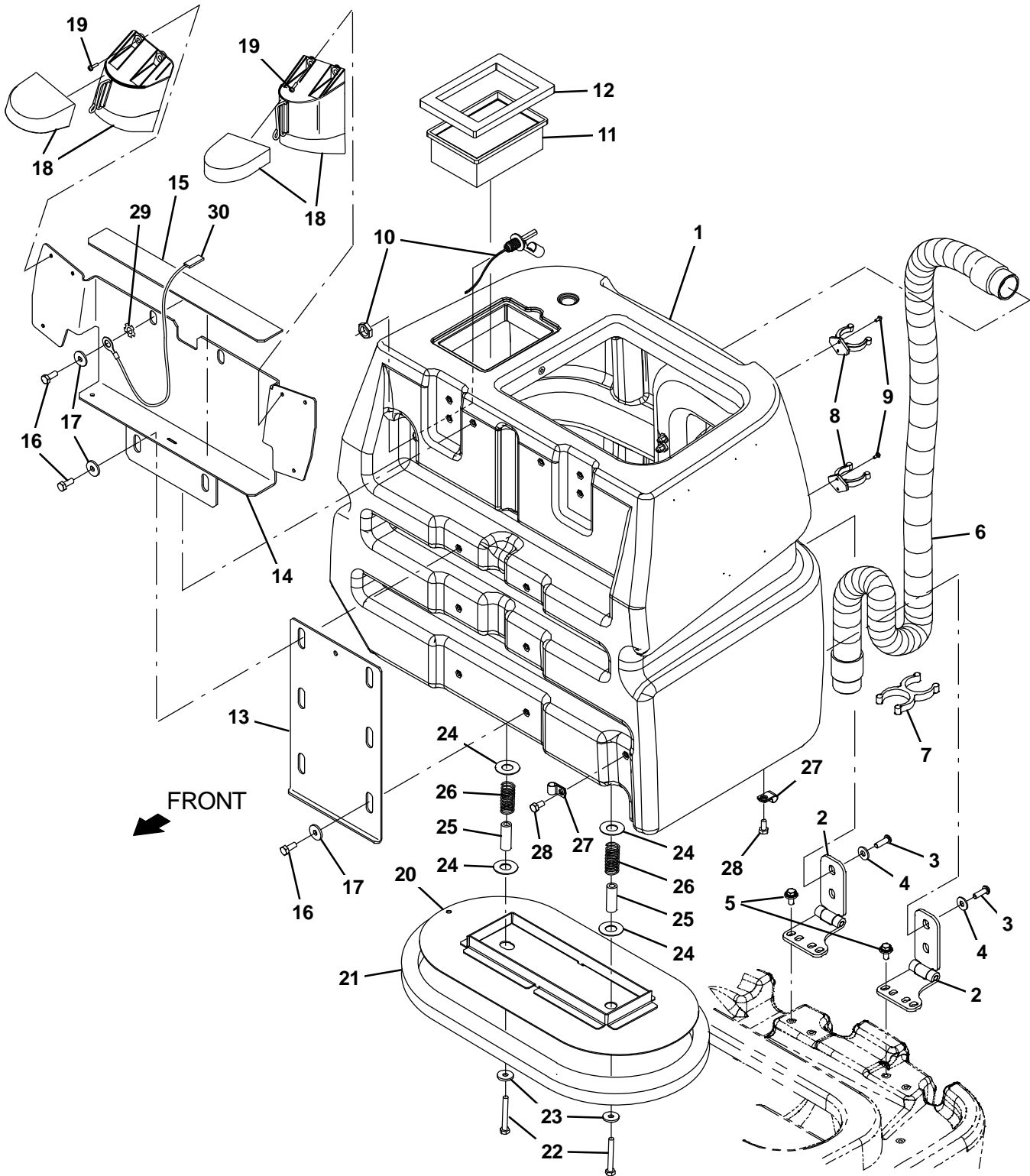

Fig. 14 – Recovery Tank Group

Ref.	Part No.	Serial Number	Description	Qty.
1	9018602	(10000000–) Tank, Recvy, Rm–Cptl, Afmkt [T7Amr]	1
2	1018304	(10000000–) Hinge, 10mm Pin, Crs, Blk [T7]	2
3	393135	(10000000–) Screw, Btn, M8 X 1.25 X 20, Blk	4
4	1016435	(10000000–) Washer, Flat, 0.38b 0.90d .08, Stl, Blk	4
5	1020341	(10000000–) Screw, Hex, M8 X 1.25 X 20, Ss, Sems	4
6	1014026	(10000000–) Hose, Vacuum, 1.50id X 057.1l, 2cuff,Blk	1
7	1014079	(10000000–) Clip, Grip, Hose, 1.50id, Dbl, Blk Pyp	1
8	1001992	(10000000–) Clip, Grip, hose, 1.75id, Blk Ny	2
9	607006	(10000000–) Screw, Trs, M4 X 0.70 X 12, Phl, Pl	4
10	385685	(10000000–) Sensor, Level, Liq, 14Vdc 01A .62–11	1
11	1037821	(10000000–) Filter, Panl, Dust, 2.3 X 04.5 X 06.4	1
12	1016392	(10000000–) Gasket, Ure, .50, 03.74w 05.31l, Adh	1
13	1017670	(10000000–) Angle, Sppt, Tank [T7]	1
14	1242239	(10000000–) Bracket Wldt, Tank, Sppt	1
15	1017705	(10000000–) Pad, Rbr, 0.12 X 1.9 X 15.3, Adh	1
16	09740	(10000000–) Screw, Hex, M8 X 1.25 X 20, Ss	8
17	1017218	(10000000–) Washer, Flat, 0.32b 1.00d .12, Ss	8
18	1242245	(10000000–) Belt, Retractable	2
19	24265	(10000000–) Screw, Pan, Phl, M4 X 0.70 X 16, Ss	6
20	1016855	(10000000–) Plate Wldt, Seal, Tank [T7/R14]	1
21	1020301	(10000000–) Seal, Afmkt, Bulb, Clsd Cell, Adh, 08ft	1
22	77270	(10000000–) Screw, Hex, M8 X 1.25 X 60, Ss	2
23	1017218	(10000000–) Washer, Flat, 0.32b 1.00d .12, Ss	2
24	605385	(10000000–) Washer, Flat, 0.69b 1.50d .05, Ss	4
25	1016871	(10000000–) Spacer, Pvc, 0.35id 0.63od 02.0l	2
26	397255	(10000000–) Spring, Cmpr, 0.90od .08wir 02.0l	2
27	82829	(10000000–) Clamp, Cable, Stl, 0.63d X 0.75w, 1hole	2
28	15675	(10000000–) Screw, Hex, M8 X 1.25 X 16, Ss	2
29	41141	(10000000–) Washer, Lock, Int–Ext, 0.31	1
30	1074344	(10000000–) Harness, Ele [Ring With .250M Tail]	1

Fig. 15 – Recovery Tank Cover and Lights Group

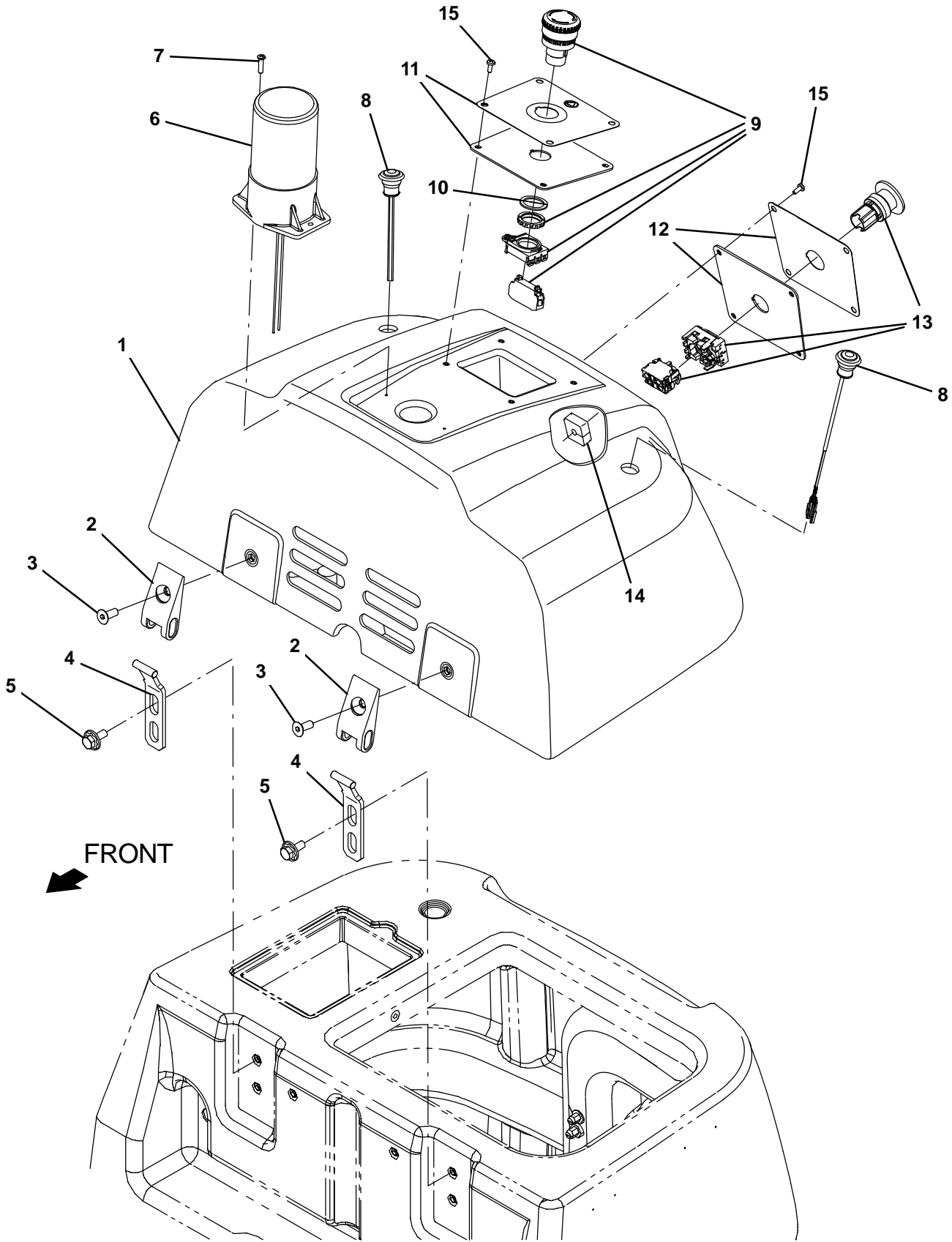

Fig. 15 – Recovery Tank Cover and Lights Group

Ref.	Part No.	Serial Number	Description	Qty.
1	1241986	(10000000–) Cover, Recvy Tank, Trimmed	1
2	1050554	(10000000–) Hinge, Leaf [T7, 5680/5700]	2
3	222463	(10000000–) Screw, Flt, Soc, M8 X 1.25 X 20, Al, Blk	2
4	1012055	(10000000–) Hinge Wldt, Cover	2
5	1020341	(10000000–) Screw, Hex, M8 X 1.25 X 20, Ss, Sems	4
6	1014564	(10000000–) Light, Strobe, 12–80vdc, 4watt	1
7	360943	(10000000–) Screw, Pan, Phl, 10–14 X 0.75, F/ Plstc	2
8	1240252	(10000000–) Light, Marker	2
9	1242161	(10000000–) Switch, Safety, Shutoff	1
10	1242538	(10000000–) Ring, Lock, E–Stop	1
11	9018623	(10000000–) Plate Kit, Label, E–Stop	1
12	9018624	(10000000–) Plate Kit, Label [Play/Pause]	1
13	1240637	(10000000–) Switch, Push, Mom, Blue	1
14	1242271	(10000000–) Seal, Foam [Play/pause]	1
15	1014754	(10000000–) Screw, Trs, M4 X 0.70 X 8, Phl, Blk	8

Fig. 16 – Vacuum Fan Group

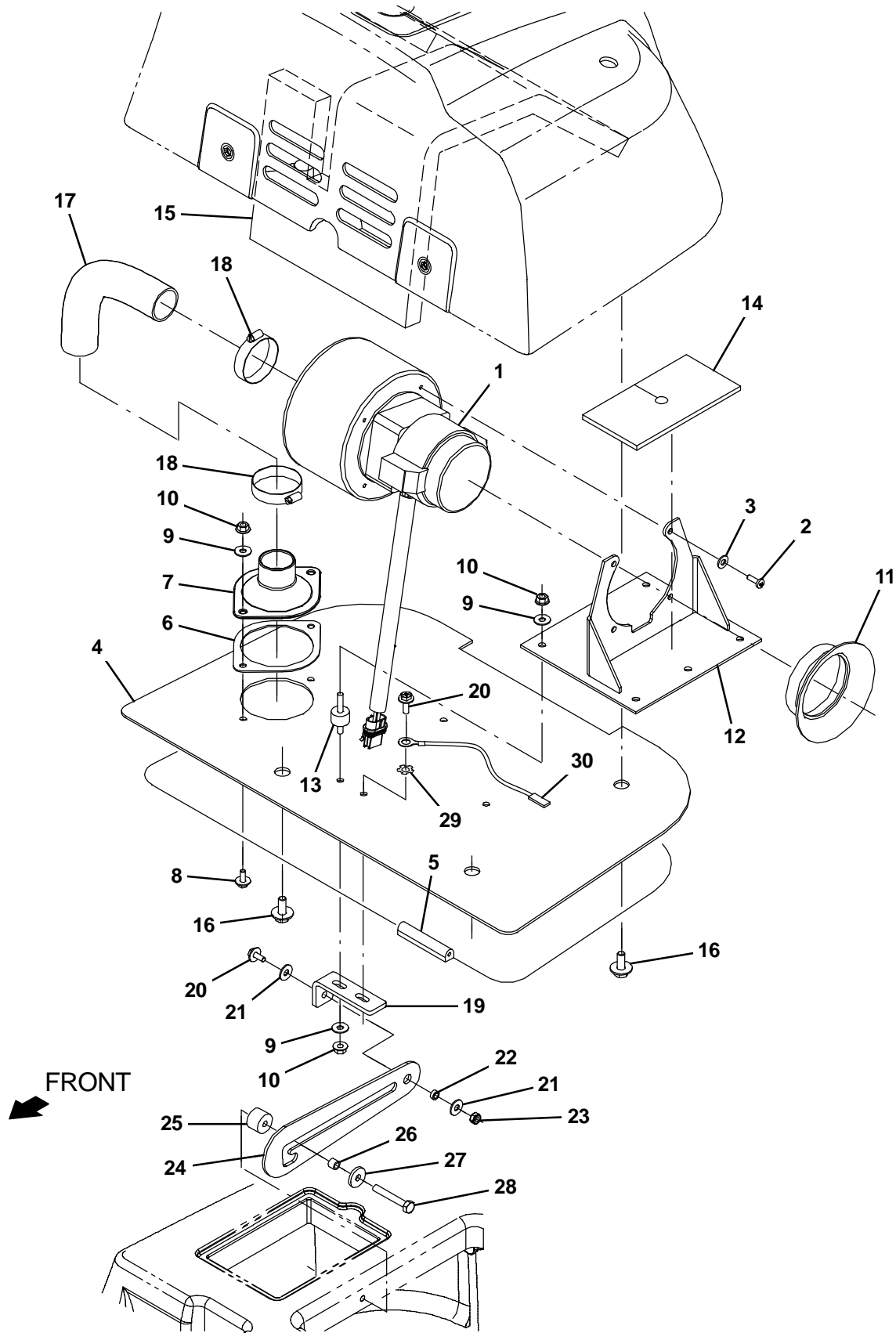

Fig. 16 – Vacuum Fan Group

Ref.	Part No.	Serial Number	Description	Qty.
1	1039763	(10000000–) Fan, Vacuum, 5.7d, 024vdc, 3 Stage [Bpp] (See Breakdown)	1
1	1021064	(10000000–) Fan, Vacuum, 5.7d, 024vdc, 3 Stage [Bpp] (Australia) (See Breakdown)	1
2	1015506	(10000000–) Screw, Pan, Phl, M5 X 16, Tcut [Plastic]	4
3	19066	(10000000–) Washer, Flat, 0.25b 0.56d .05, Pl, 10	4
4	1011127	(10000000–) Plate, Mtg, Fan [T7]	1
5	1013611	(10000000–) Seal, Bulb, Str, 0.50h .50w 062.5l, Adh	1
6	1014858	(10000000–) Gasket, Ure, .06, 2.99id, 2/3.9bc	1
7	1014711	(10000000–) Adapter, Hose	1
8	1034731	(10000000–) Screw, Hex, M6 X 1.00 X 16, Sems, Ss	2
9	01684	(10000000–) Washer, Flat, 0.27b 0.69d .05, Ss	9
10	07790	(10000000–) Nut, Hex, Flng, M6 X 1.00	9
11	1011140	(10000000–) Seal, Fan	1
12	1011103	(10000000–) Bracket Wldt, Mtg, Fan [T7]	1
13	1011093	(10000000–) Isolator, Vib, .75d, M6 Stud Both Ends	3
14	1028514	(10000000–) Insulation, Acstc, Vacfan	1
15	1242311	(10000000–) Insulation, Acstc, Hsng, Vacfan Laguna	1
16	1020341	(10000000–) Screw, Hex, M8 X 1.25 X 20, Ss, Sems	4
17	1011159	(10000000–) Hose, Vacuum, Wir, 1.50id X 008.3l, Clr	1
18	79381	(10000000–) Clamp, Hose, Wormdrive, 1.25–2.00d, .50w	2
19	1026322	(10000000–) Bracket, Mtg, Stop	1
20	1034731	(10000000–) Screw, Hex, M6 X 1.00 X 16, Sems, Ss	2
21	01684	(10000000–) Washer, Flat, 0.27b 0.69d .05, Ss	2
22	80491	(10000000–) Sleeve, P/M, 0.25b 0.38d 0.2l [430ss]	1
23	08712	(10000000–) Nut, Hex, Lock, M6 X 1.00, NI, Ss	1
24	1026270	(10000000–) Bracket, Arm, Prop [T7, R14]	1
25	578579	(10000000–) Spacer, Plstc, 0.25b 0.88d 0.63l, Nyl	1
26	140154	(10000000–) Sleeve, P/M, 0.25b 0.38d 0.3l, Pl	1
27	140053	(10000000–) Washer, Flat, 0.28b 0.88d .12, Ss	1
28	06946	(10000000–) Screw, Hex, M6 X 1.00 X 35, 8.8	1
29	41140	(10000000–) Washer, Lock, Int–Ext, 0.25	1
30	1076527	(10000000–) Harness, Ele [Jumper, M6 Ring, .250M]	1

Fig. 17 – Solution Tank Group, Disk Scrub Head

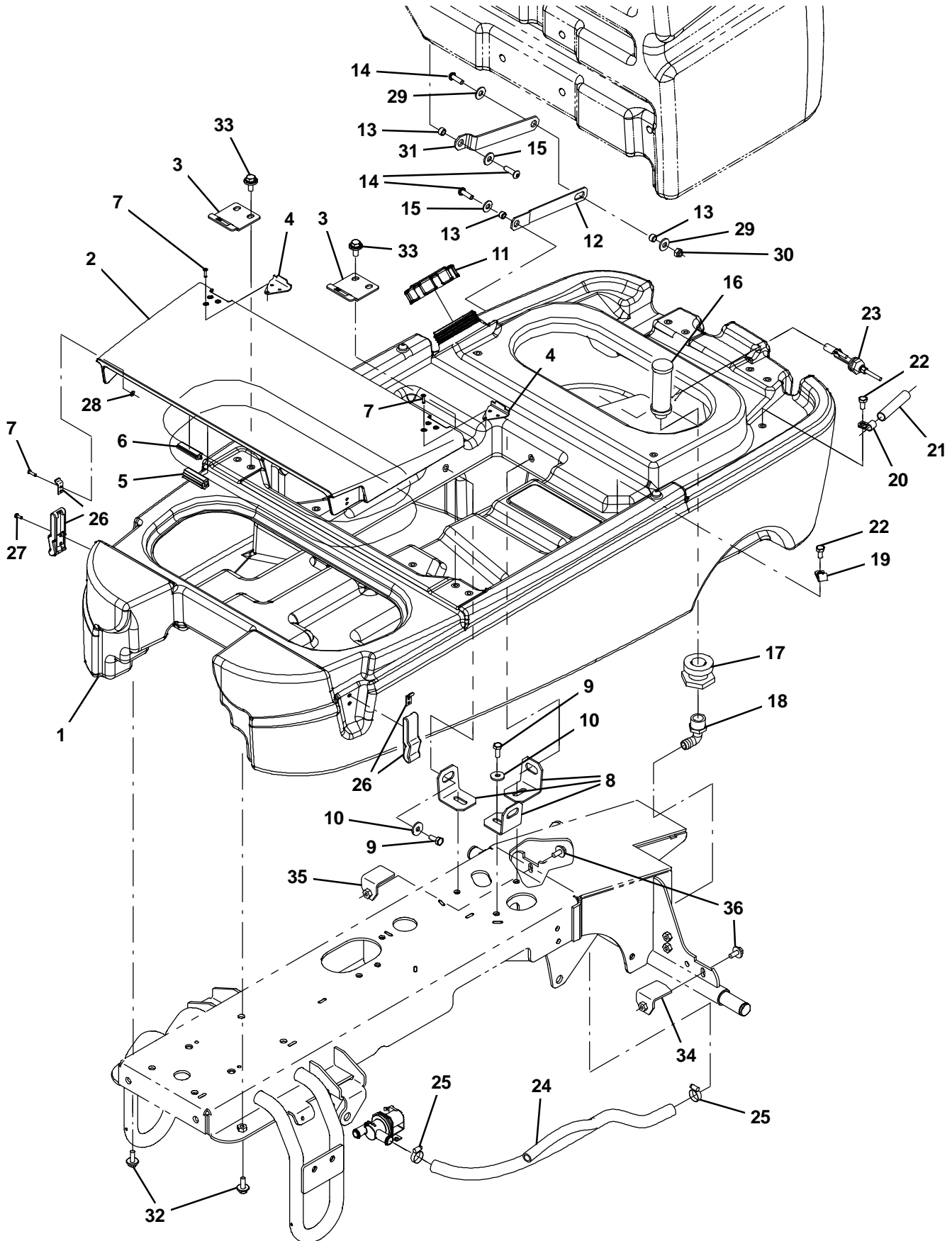

Fig. 17 – Solution Tank Group, Disk Scrub Head

Ref.	Part No.	Serial Number	Description	Qty.
1	1015405	(10000000–) Tank, Soltn, W/ Label [T7]	1
1	1036374	(10000000–) Tank, Soltn, Disk, Hg, Afmkt, Tj (Japan)	1
2	1012505	(10000000–) Cover, Tank, Soltn [T7]	1
3	1020317	(10000000–) Catch, Cover [T7]	2
4	1020292	(10000000–) Plate, Cover, Tab [T7]	2
5	1020727	(10000000–) Seal, Afmkt, Bulb, Clsd Cell, Adh, 8ft	1
6	1020719	(10000000–) Seal, Afmkt, Bulb, Clsd Cell, Adh, 8ft	1
7	1021677	(10000000–) Rivet, Blind, .156DX0.55X.38D, Ss	10
8	1014072	(10000000–) Bracket, Mtg, Tank	3
9	09740	(10000000–) Screw, Hex, M8 X 1.25 X 20, Ss	6
10	1017218	(10000000–) Washer, Flat, 0.321b 1.00d .12, Ss	6
11	1011885	(10000000–) Cap, Tank	1
12	1011852	(10000000–) Arm, Tank, Retaining	1
13	222516	(10000000–) Sleeve, P/M, 0.496d 0.318b 0.31l 430ss	5
14	1016430	(10000000–) Screw, Btn, M8 X 1.25 X 25,10.9, Blk	4
15	1016435	(10000000–) Washer, Flat, 0.52b 0.75d .06, Stl, Blk	3
16	398770	(10000000–) Strainer, Soltn, 80mesh Cyl 1.3d 3.5l	1
17	377349	(10000000–) Fitting, Plstc, Pf12/Pf12, Bh	1
18	73468	(10000000–) Fitting, Plstc, E90, Bm10/Pm12	1
19	82829	(10000000–) Clamp, Cable, Stl, 0.63d X 0.75w, 1hole	2
20	67767	(10000000–) Clamp, Cable, Stl, 0.69d X 0.62w, 1h	1
21	1019879	(10000000–) Conduit, Nylon, .50d 3.0l	1
22	15675	(10000000–) Screw, Hex, M8 X 1.25 X 16, Ss	2
23	385685	(10000000–) Sensor, Level, Liquid, 14vdc 01a .62–11	1
24	1014825	(10000000–) Hose, Mold	1
25	54333	(10000000–) Clamp, Hose, Wormdrive, 0.31–0.88d, .31w	2
26	49800	(10000000–) Latch, Draw, Soft, Rbr W/ Keeper	2
27	607006	(10000000–) Screw, Trs, M4 X 0.70 X 12, Phl, PI	4
28	1035394	(10000000–) Washer, Flat, 0.17b 0.38d .04, Ss	4
29	01685	(10000000–) Washer, Flat, 0.31 Ss	2
30	08713	(10000000–) Nut, Hex, Lock, M8 X 1.25, NI, Ss	1
31	1011853	(10000000–) Arm, Tank, Retaining	1
32	1072628	(10000000–) Screw, Hex, M8 X 1.25 X 25, Ss, Sems	2
33	1020341	(10000000–) Screw, Hex, M8 X 1.25 X 20, Ss, Sems	4
34	1075258	(10000000–) Bracket, Mount, Tank [Disk]	1
35	1075252	(10000000–) Bracket, Mount, Tank	1
36	1020341	(10000000–) Screw, hex, M8 X 1.25 X 20, Ss, Sems	2

Fig. 18 - Tanks Drain Group

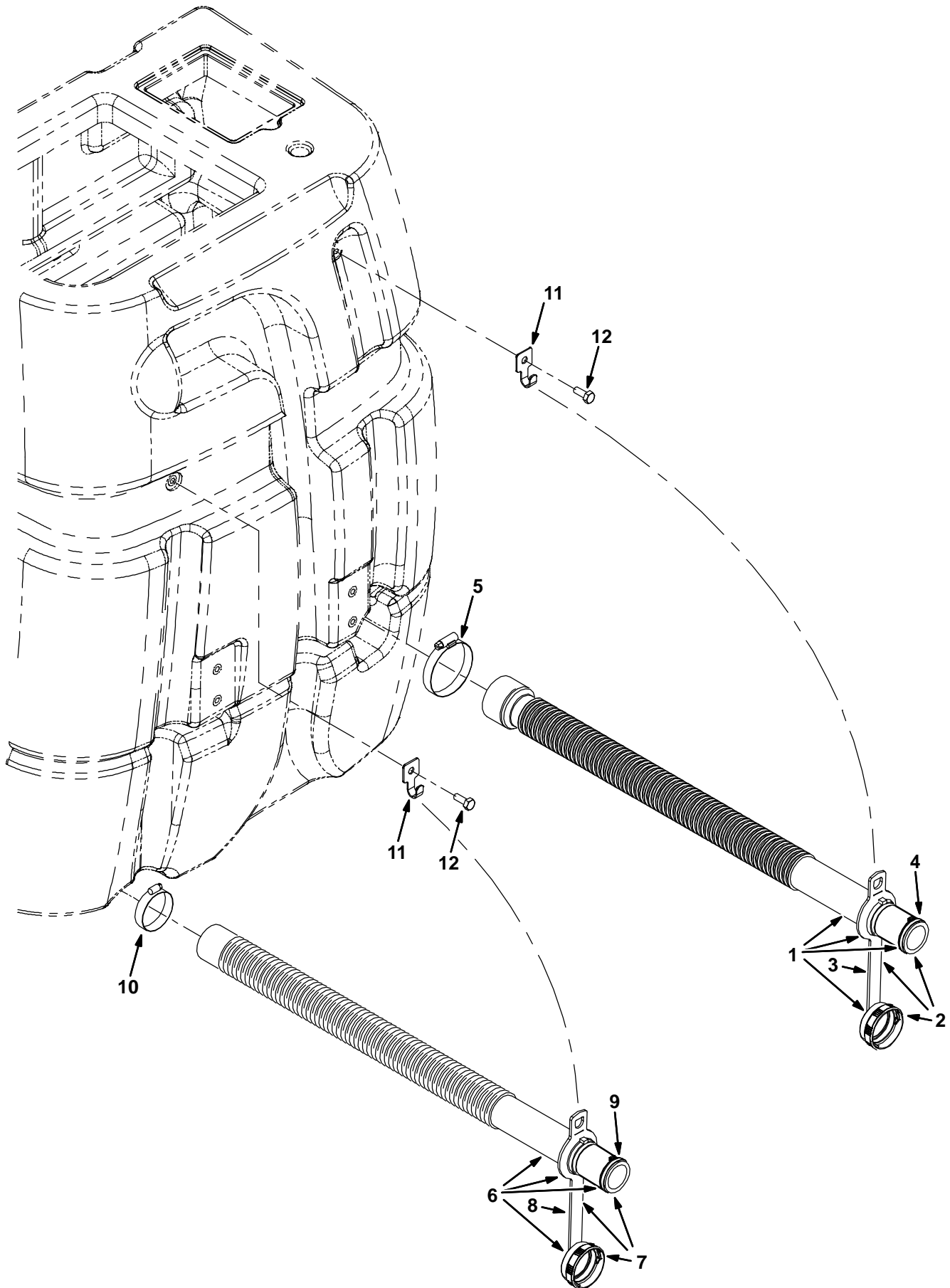

Fig. 18 – Tanks Drain Group

	Ref.	Part No.	Serial Number	Description	Qty.
▽	1	1014274	(10000000–) Hose Assy, Drain, 27.8l (Recovery Tank)	1
▲▽	2	1008639	(10000000–) Cap, Drain Assembly	1
▲▲	3	1019563	(10000000–) Strap, Drain Cap	1
▲▲	4	1008637	(10000000–) O Ring, 1.48" Id, 1.76" Od	1
	5	14432	(10000000–) Clamp, Hose, Wormdrive, 1.81–2.75d, .56w	2
▽	6	1014268	(10000000–) Hose Assy, Drain, 27.0l (Solution Tank)	1
▲▽	7	1008639	(10000000–) Cap, Drain Assembly	5
▲▲	8	1019563	(10000000–) Strap, Drain Cap	1
▲▲	9	1008637	(10000000–) O Ring, 1.48" Id, 1.76" Od	1
	10	79381	(10000000–) Clamp, Hose, Wormdrive, 1.25–2.00d, .50w	1
	11	222793	(10000000–) Clip, Hanger, Hose, .38d Hole, Ss	2
	12	09740	(10000000–) Screw, Hex, M8 X 1.25 X 20, Ss	2

▽ Assembly

▲ Included in Assembly

Fig. 19 - Battery Group

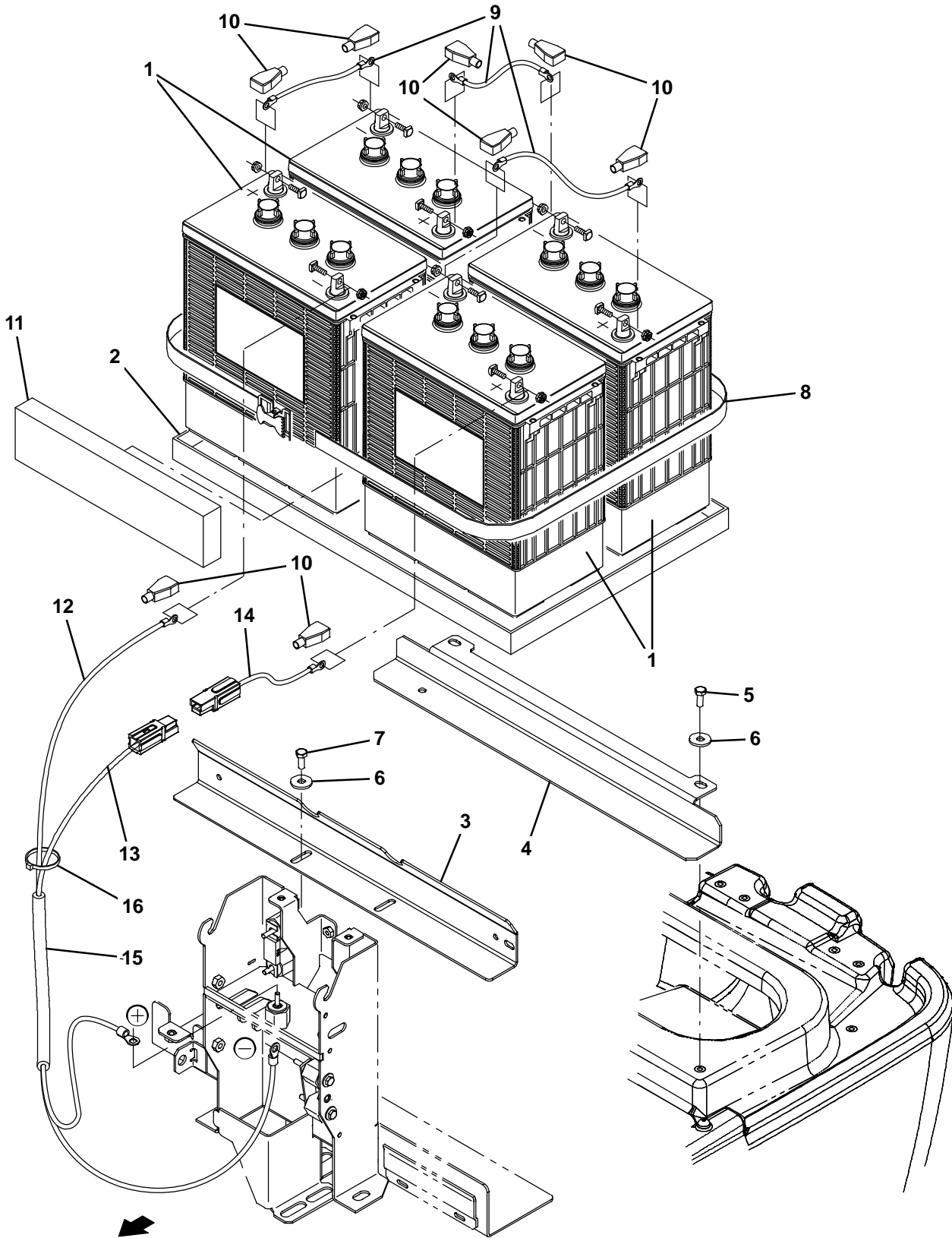

Fig. 19 – Battery Group

Ref.	Part No.	Serial Number	Description	Qty.	
1	1070587	(10000000–) Battery, Wt, 06Vdc 0360Ah, W/Cart [Tr]	4	
2	1025155	(10000000–) Tray, Battery, 605x370x25	1	
3	1042532	(10000000–) Bracket, Battery [T7, 220ah Agm]	1	
4	1010771	(10000000–) Angle, Sppt, Battery	1	
5	09740	(10000000–) Screw, Hex, M8 X 1.25 X 20, Ss	2	
6	1017218	(10000000–) Washer, Flat, 0.321b 1.00d .12, Ss	4	
7	15675	(10000000–) Screw, Hex, M8 X 1.25 X 16, Ss	2	
8	222682	(10000000–) Strap	1	
9	223356	(10000000–) Wire, 04ga 12.0l Blk .34ring /.34ring	3	
10	68872	(10000000–) Boot, Terminal, Battery, 02–01Ga, Blk	8	
11	630375	(10000000–) Spacer, Battery, Foam, 1.25 X 3.3 X 13.7	1	
12	223364	(10000000–) Cable, 04Ga 18.8L Blk .34Ring /.34Ring	1	
13	397907	(10000000–) Cable, 04Ga 30.0L Red .31Ring /[Pp120]	1	
▽	14	397908	(10000000–) Cable, 04Ga 08.0L Red .31Ring /[Pp120]	1
▲	1020446	(10000000–) Connector, Anderson, 1321 Series	1	
▲	1020447	(10000000–) Terminal, Contact, Anderson, 1319g4, 4ga	1	
15	1020105	(10000000–) Sleeve, Afmkt, Nyl, #13, 1ft	1	
16	49263	(10000000–) Tie, Cable, Nyl, 11.4l .19w 3.0 Max D	3	

▽ Assembly

▲ Included in Assembly

Fig. 20 – Rear Squeegee Lift Group, Disk Scrub Head

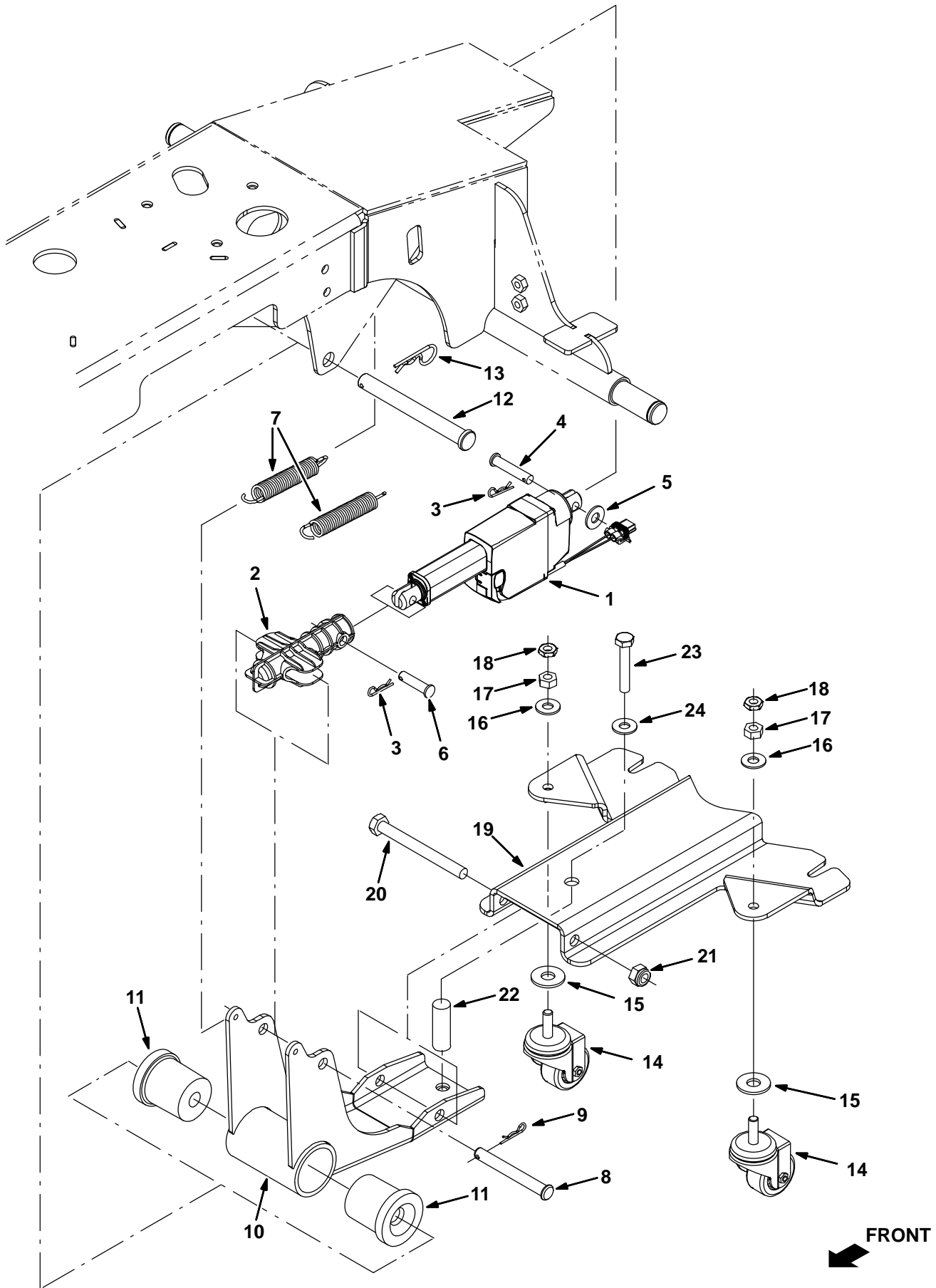

Fig. 20 – Rear Squeegee Lift Group, Disk Scrub Head

	Ref.	Part No.	Serial Number	Description	Qty.
▽	1	9010845	(10000000–) Actuator Kit, Replmt [T7/Ssr]	1
▲	2	1031028	(10000000–) Housing, Sqge, Spring, Actuator	1
	3	86866	(10000000–) Pin, Hair Cotter, 0.38 D .072 Wir	2
	4	94877	(10000000–) Pin, Clevis, 10d X 50l	1
	5	01686	(10000000–) Washer, Flat, 0.44b 1.00 .08, Ss	1
	6	1009356	(10000000–) Pin, Clevis , 10mm X 40l	1
	7	1016639	(10000000–) Spring, Extn, 0.75od X 0.11wir, 4.5l	2
	8	96184	(10000000–) Pin, Clevis, 12d X 100l, Pl	1
	9	86866	(10000000–) Pin, Cotter, Hair, 0.38d .072 Wir	1
	10	1031379	(10000000–) Arm Wldt, Sqge, Rear	1
	11	1013515	(10000000–) Bushing, Flex, Ure	2
	12	1010401	(10000000–) Pin, Clevis, 16d X 150l	1
	13	02942	(10000000–) Pin, Hair Cotter, 0.62 D .120 Wir	1
	14	1073476	(10000000–) Caster, Swivel, 50mmd, M10 X 30, Clr Pl	2
	15	41619	(10000000–) Washer, Flat, 0.56b 1.38d .11, Ss	2
	16	01686	(10000000–) Washer, Flat, 0.44b 1.00 .08, Ss	2
	17	07787	(10000000–) Nut, Hex, Std, M10 X 1.5, Ss	2
	18	32716	(10000000–) Nut, Hex, Jam, M10 X 1.5, Ss	2
	19	1018725	(10000000–) Channel, Arm, Lower Sqge	1
	20	12138	(10000000–) Screw, Hex, M12 X 1.75 X 120, 8.8	1
	21	09741	(10000000–) Nut, Hex, Lock, M12 X 1.75, NI, Ss	1
	22	1020182	(10000000–) Spring, Cmpr, 20mm D X 44mm L	1
	23	04417	(10000000–) Screw, Hex, M10 X 1.5 X 60, Ss	1
	24	01686	(10000000–) Washer, Flat, 0.44b 1.00 .08, Ss	1

▽ Assembly

▲ Included in Assembly

Fig. 21 – Rear Squeegee Group, 650 mm (26 in)

	Ref.	Part No.	Serial Number	Description	Qty.
▽		9000139	(10000000–) Squeegee Assy Kit, 650mm, Ci [T7/Ssr]	1
▲	1	1001468	(10000000–) Frame, Sqge, 700mm	1
▲	2	1012934	(10000000–) Plate Wldt, Sqge, Retainer, 700mm	1
▲	3	1054375	(10000000–) Knob, Star, 2.75d 4ear 1.1l M8x1.25,Thru	4
▲	4	390943	(10000000–) Blade, Sqge, Front, 35.00l [Linx, 700mm]	1
▲	5	390942	(10000000–) Blade, Sqge, Rear, 37.50l Linatex[700mm]	1
▲	6	1033158	(10000000–) Strap Assy, Sqge, 700mm	1
▲	7	1010560	(10000000–) Wheel, Bmpr, 80d X 25w, Non-Marking	2
▲	8	09011	(10000000–) Screw, Hex, M8 X 1.25 X 30, Ss	2
▲	9	140027	(10000000–) Washer, Flat, 0.35b 0.75d .04, Ss	2
▲	10	222460	(10000000–) Sleeve, P/M, 0.496d 0.318b 0.50l 430ss	2
▲	11	08713	(10000000–) Nut, Hex, Lock, M8 X 1.25, NI, Ss	2
▲	12	01685	(10000000–) Washer, Flat, 0.38b 0.88d .08, Ss	2
▽		391384	(10000000–) Squeegee Kit, 700mm, Ure	1
▲	13	391377	(10000000–) Blade, Sqge, Front, 35.00l Ure [700mm]	1
▲	14	391378	(10000000–) Blade, Sqge, Rear, 37.50l Pyu [700mm]	1
▽		391386	(10000000–) Squeegee Kit, 700mm, Gum	1
▲	15	390943	(10000000–) Blade, Sqge, Front, 35.00l [Linx, 700mm]	1
▲	16	390936	(10000000–) Blade, Sqge, Rear, 37.50l Gum [700mm]	1

▽ Assembly

▲ Included in Assembly

Fig. 22 -Front Camera and Sensors Group

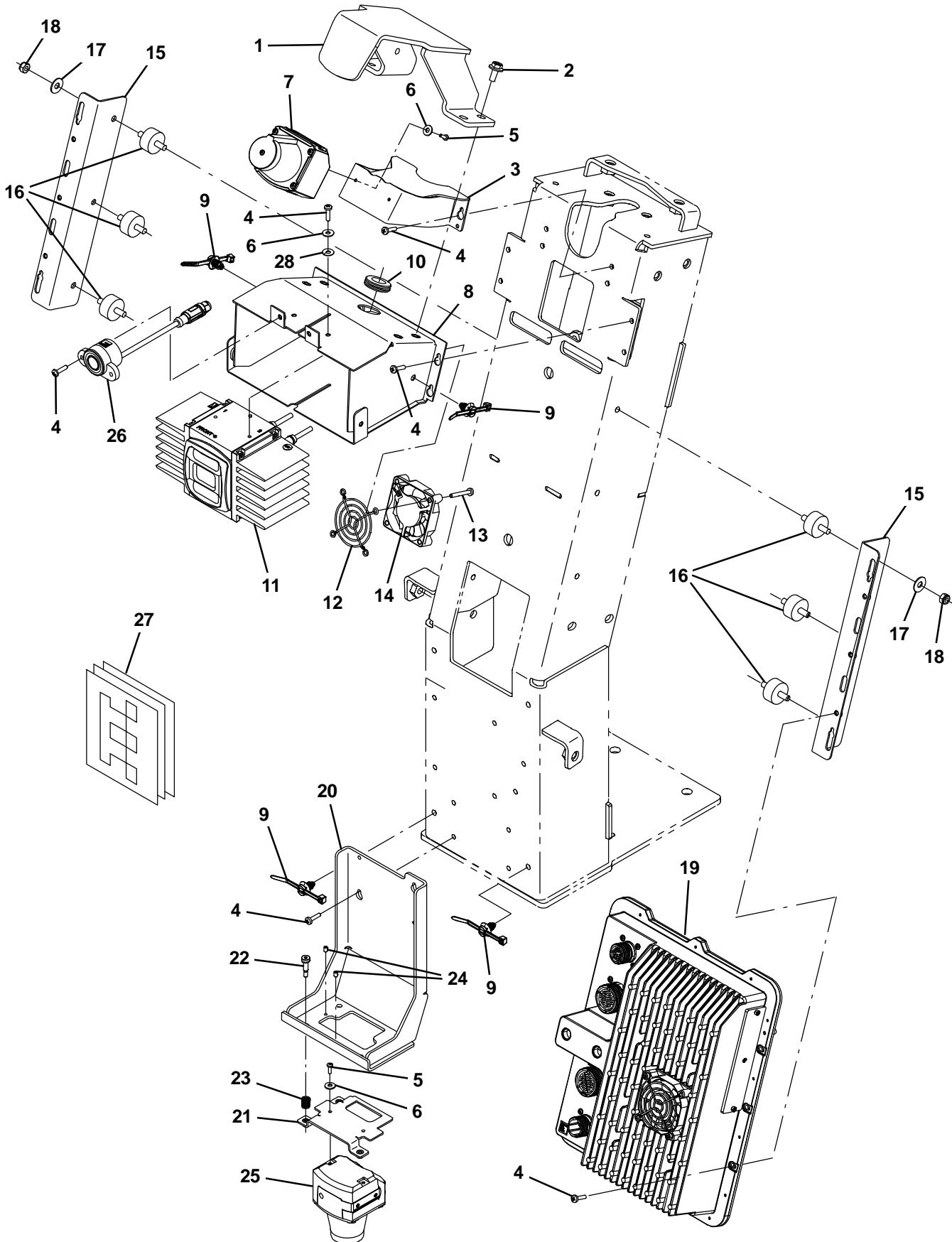

Fig. 22 – Front Camera and Sensors Group

Ref.	Part No.	Serial Number	Description	Qty.
1	1241964	(10000000–) Bracket Wldt, Hood, Sensor	1
2	1034731	(10000000–) Screw, Hex, M6 X 1.00 X 16, Sems, Ss	4
3	1241658	(10000000–) Bracket Wldt, Sensor, Upper	1
4	24265	(10000000–) Screw, Pan, Phl, M4 X 0.70 X 16, Ss	22
5	06920	(10000000–) Screw, Pan, Phl, M3 X 0.50 X 10, 4.8	4
6	19065	(10000000–) Washer, Flat, 0.19b 0.44d .05, Pl, 08	6
7	9018604*	(10000000–) Sensor, Range, Amr, Afmkt [Lidar Tim551]	1
8	1241139	(10000000–) Bracket Wldt, Camera	1
9	1210807	(10000000–) Wire, Tie [W/.25" Fir Tree Clip]	4
10	10632–4	(10000000–) Grommet, Rbr, 0.62id, F/0.9h, .06 Matl	1
11	9018605*	(10000000–) Camera Assy, Front, Afmkt [3d lfm O3d]	1
12	1240631	(10000000–) Guard, Fan	1
13	33931	(10000000–) Screw, Pan, Phl, M4 X 0.70 X 30, Ss	4
14	1240113	(10000000–) Fan, Cooling, Camera	1
15	1241565	(10000000–) Bracket Wldt, Controller	2
16	1240009	(10000000–) Isolator, Vib, 1.0d 0.5l M6/M6	6
17	01684	(10000000–) Washer, Flat, 0.27b 0.69d .05, Ss	6
18	08712	(10000000–) Nut, Hex, Lock, M6 X 1.00, NI, Ss	6
19	9018606*	(10000000–) Controller, Amr, Afmkt [Bcm]	1
20	1241419	(10000000–) Bracket, Sensor, Lower	1
21	1241407	(10000000–) Plate Assy, Lidar, Lower	1
22	1240075	(10000000–) Bolt, Shld, 05mmd X 012mm, M4 X 0.7	3
23	1240077	(10000000–) Spring, Cmpr, .36od, .04wir, 0.75l, Ss	3
24	1240459	(10000000–) Screw, Set, M4 X 0.70 X 6, NI	2
25	9018607*	(10000000–) Sensor, Range, Amr, Afmkt [Lidar Tim571]	1
26	1240062	(10000000–) Camera, Amr [2d]	1
27	1242894	(10000000–) Sign Kit, Amr [Home Location]	1
28	02938	(10000000–) Washer, Lock, Int, 08, Ss	1

* Requires Tennant *True* service or an authorized Tennant service provider.

Fig. 23 – Electrical Controller Group

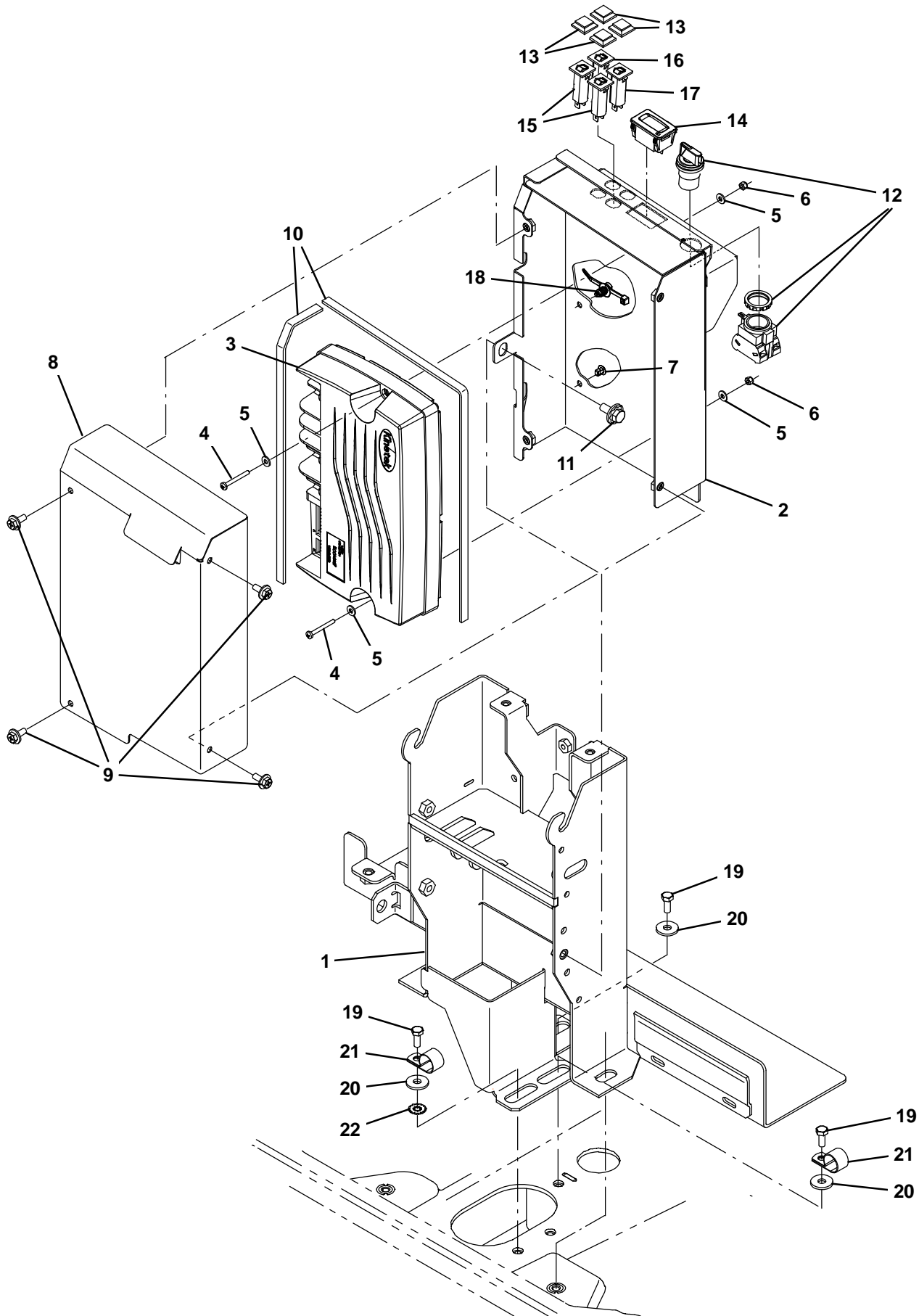

Fig. 23 – Electrical Controller Group

Ref.	Part No.	Serial Number	Description	Qty.
1	1243110	(10000000–) Support Wldt, Actuator	1
2	1242088	(10000000–) Panel Wldt, Mount, Controller	1
3	9018609*	(10000000–) Controller, Mach, Afmkt	1
4	06930	(10000000–) Screw, Pan, Phl, M4 X 0.70 X 30, 4.8	2
5	41579	(10000000–) Washer, Flat, 08, Ss	4
6	33932	(10000000–) Nut, Hex, Lock, M4 X 0.70, NI, Ss	2
7	1202868	(10000000–) Clip, Tie, 0.25d, Plstc	1
8	1242092	(10000000–) Plate, Cover, Controller	1
9	1034731	(10000000–) Screw, Hex, M6 X 1.00 X 16, Sems, Ss	4
10	1020284	(10000000–) Seal, Afmkt, Rbr, Clsd, Adh, 03ft	1
11	1020341	(10000000–) Screw, Hex, M8 X 1.25 X 20, Ss, Sems	1
12	9018622	(10000000–) Switch Kit, Rotary, No/Nc	1
13	1064191	(10000000–) Boot, Circuitbreaker	1
14	1064038	(10000000–) Gauge, Hourmeter, 05–277 Volt, Ac / Dc	1
15	1208816	(10000000–) Circuitbreaker, 04.0a, Resetable	2
16	1064187	(10000000–) Circuitbreaker, 10.0a, Resetable	1
17	1064189	(10000000–) Circuitbreaker, 20.0a, Resetable	1
18	1210807	(10000000–) Wire, Tie [W/.25" Fir Tree Clip]	1
19	09740	(10000000–) Screw, Hex, M8 X 1.25 X 20, Ss	5
20	1017218	(10000000–) Washer, Flat, 0.32b 1.00d .12, Ss	5
21	69234	(10000000–) Clamp, Cable, Stil, 1.00d X 0.75w, 1hole	2
22	41141	(10000000–) Washer, Lock, Int–Ext, 0.31	1

* Requires Tennant *True* service or an authorized Tennant service provider.

Fig. 24 – Electrical Group

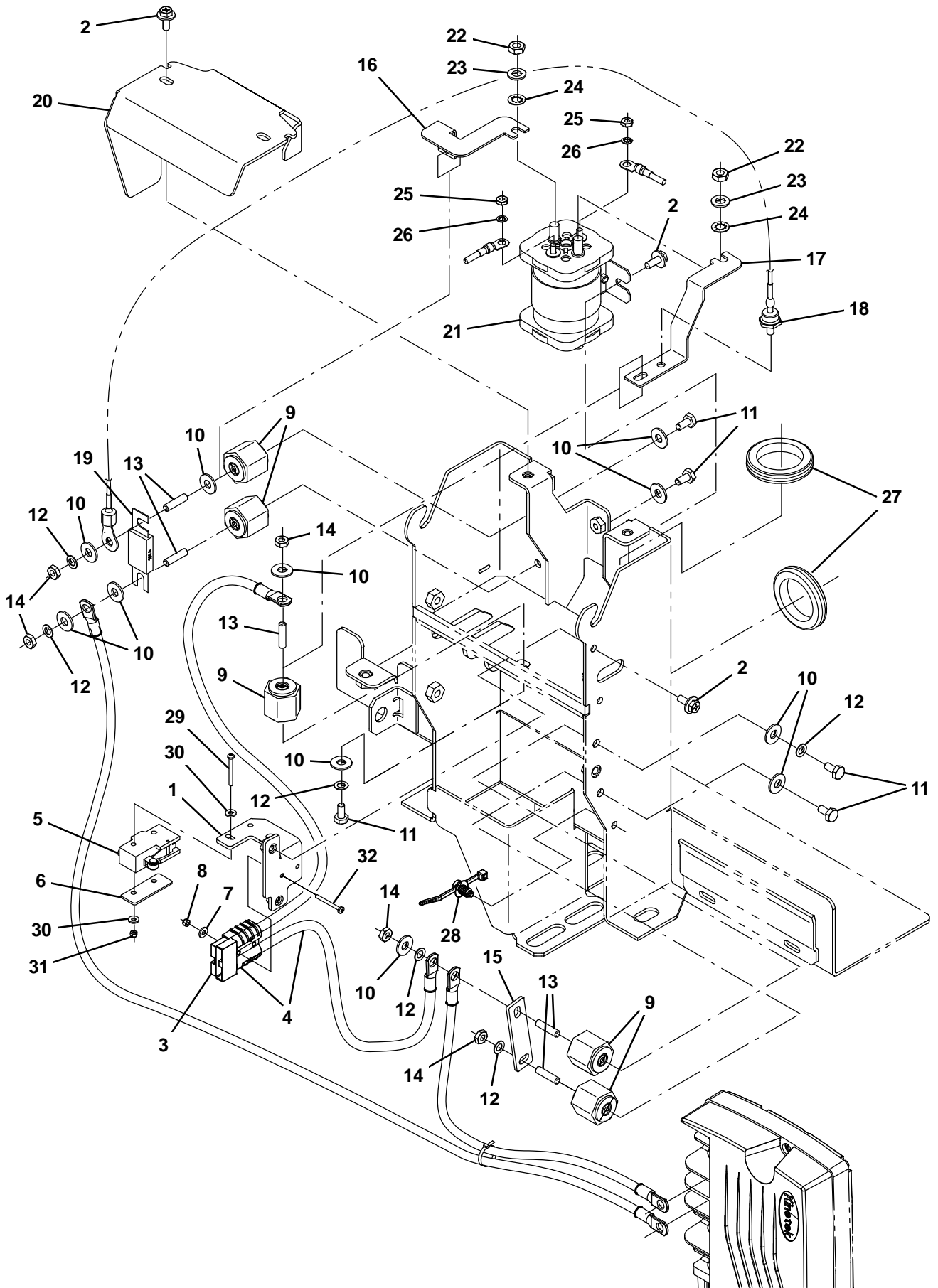

Fig. 24 – Electrical Group

Ref.	Part No.	Serial Number	Description	Qty.	
1	1242464	(10000000–) Bracket Wldt, Connector	1	
2	1034731	(10000000–) Screw, Hex, M6 X 1.00 X 16, Sems, Ss	6	
▽	3	391915	(10000000–) Harness, Chrgr [T7]	1
▲	4	605387	(10000000–) Connector, Anderson, 050A, Red [W/O Con]	2
5	1244049	(10000000–) Switch, Snap, Rlr	1	
6	1244012	(10000000–) Bracket, Switch, Plate, Rear	1	
7	19064	(10000000–) Washer, Flat, 0.16b 0.38d .05, Pl, 06	2	
8	579211	(10000000–) Nut, Hex, Lock, M3 X 0.50, NI, Ss	2	
9	76062	(10000000–) Stand-Off, Wir, 0.25, Insulator, Panel	5	
10	32490	(10000000–) Washer, Flat, 0.25, Std	10	
11	58670	(10000000–) Screw, Hex, .25–20 X 0.50, NI	5	
12	32982	(10000000–) Washer, Lock, Int, 0.25	5	
13	1017807	(10000000–) Rod, Thrd, Full, .25–20 01.0l	5	
14	32520	(10000000–) Nut, Hex, Jam, .25–20	5	
15	1243148	(10000000–) Busbar	1	
16	1243262	(10000000–) Busbar	1	
17	1243173	(10000000–) Busbar	1	
18	1240555	(10000000–) Harness, Ele [T7amr, Diode]	1	
19	86379	(10000000–) Fuse, 100a, 0.88 2.4l, 125volt	1	
20	1243000	(10000000–) Cover, Contactor	1	
21	1243585	(10000000–) Contactor, 24Vdc, 200A, Spdt	1	
22	20170	(10000000–) Nut, Hex, Jam, .31–24	4	
23	1209373	(10000000–) Washer, Flat, M8.4b X 16d X 1.6, Brs	4	
24	43952	(10000000–) Washer, Lock, Int, 0.31, Ss	4	
25	01689	(10000000–) Nut, Hex, Std, #10–32, Ss	2	
26	07514	(10000000–) Washer, Lock, Int, 10, Ss	2	
27	54345	(10000000–) Grommet, Rbr, 1.62id, F/1.9h, .13 Matl	2	
28	1210807	(10000000–) Wire, Tie [W/.25" Fir Tree Clip]	1	
29	06930	(10000000–) Screw, Pan, Phl, M4 X 0.70 X 30, 4.8	2	
30	19065	(10000000–) Washer, Flat, 0.19B 0.44D .05, Pl, 08	4	
31	33932	(10000000–) Nut, Hex, lock, M4 X 0.70, NI, Ss	2	
32	33934	(10000000–) Screw, Pan, Phl, M3 X 0.50 X 30, Ss	2	

▽ Assembly

▲ Included in Assembly

Fig. 25 – Electrical Schematic

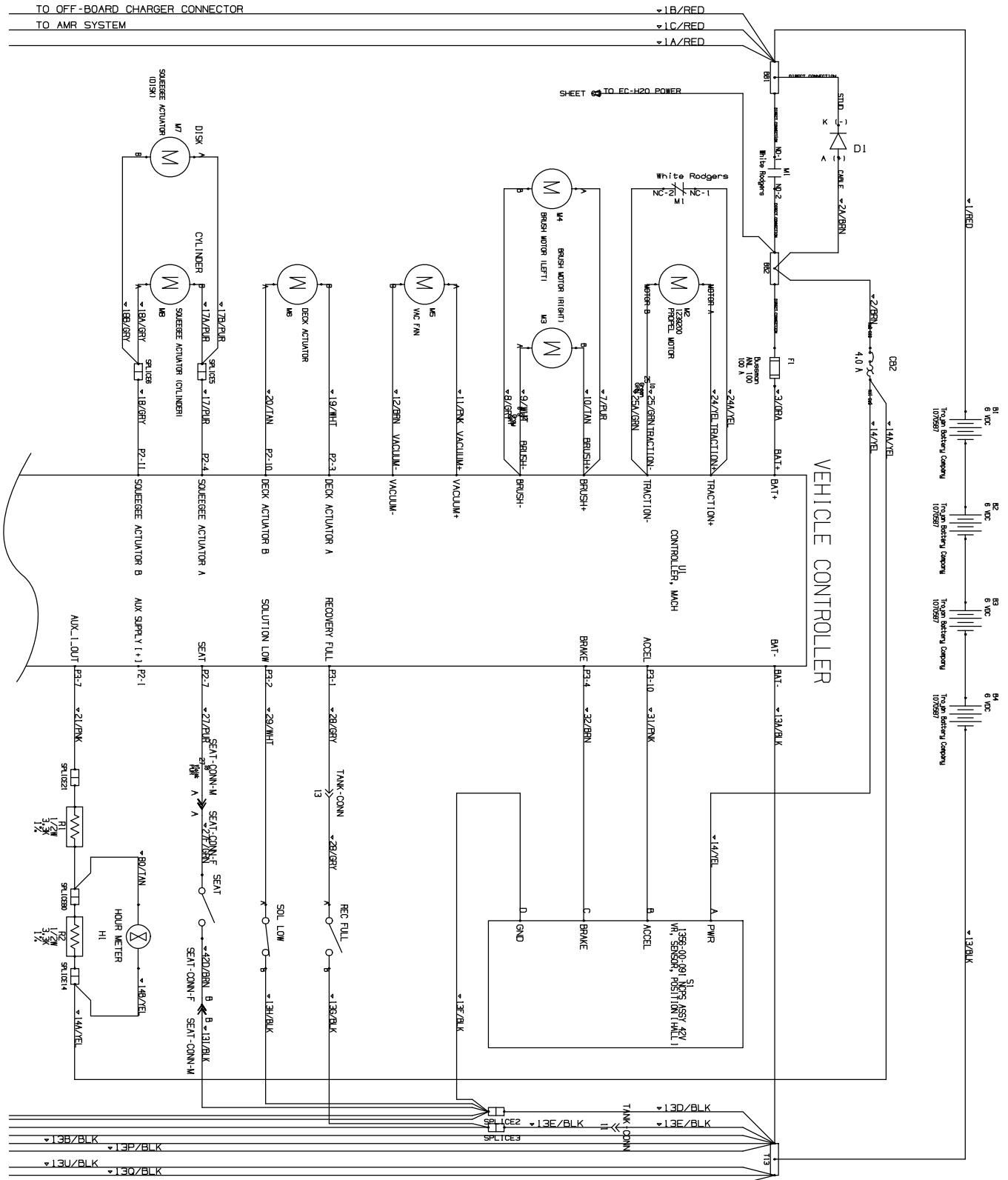

Sheet 01 – Continued

Fig. 25 – Electrical Schematic

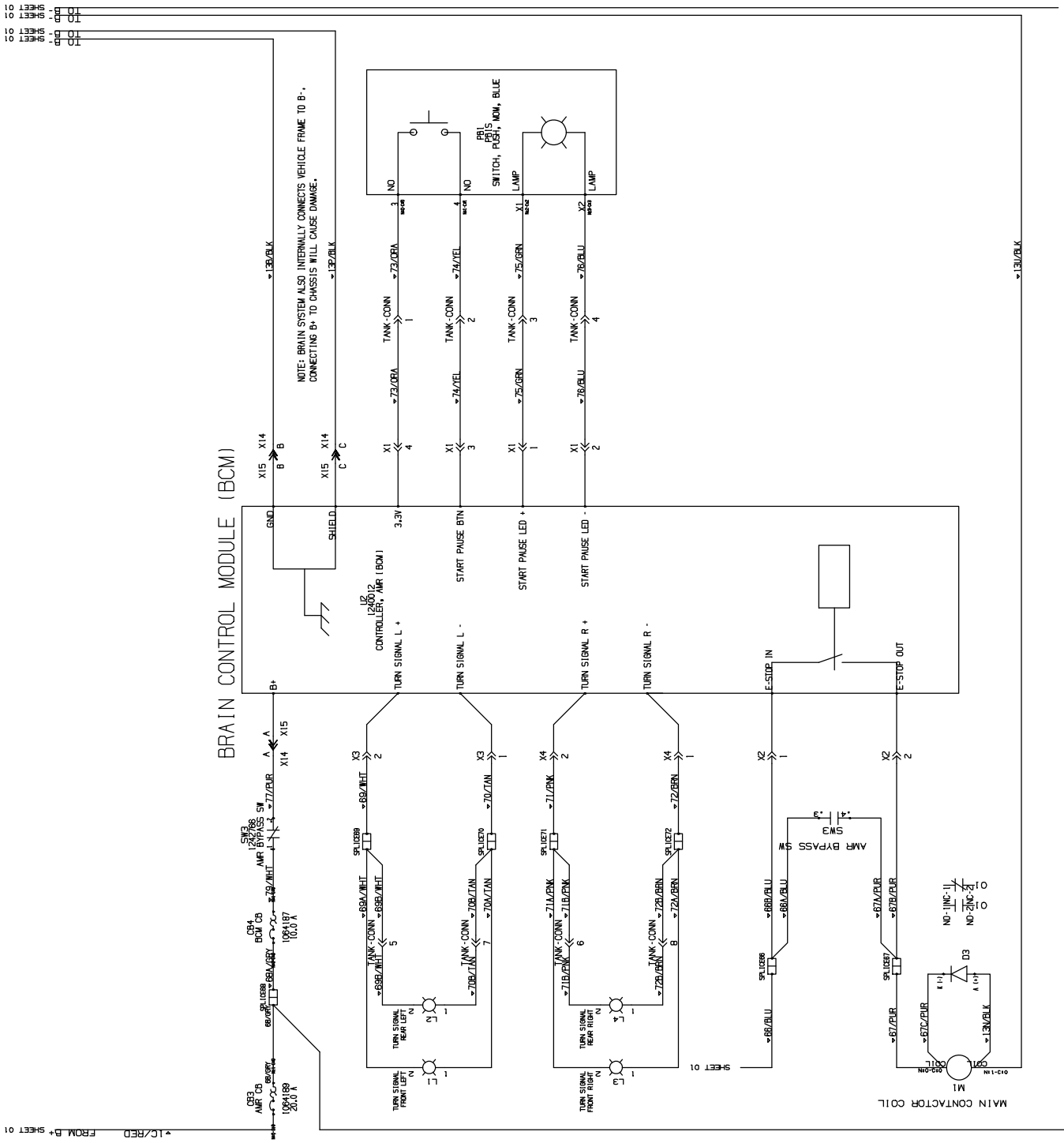

10 SHEET 01
10 SHEET 02
10 SHEET 03
10 SHEET 04
10 SHEET 05
10 SHEET 06
10 SHEET 07
10 SHEET 08
10 SHEET 09
10 SHEET 10

Fig. 25 – Electrical Schematic, Standard

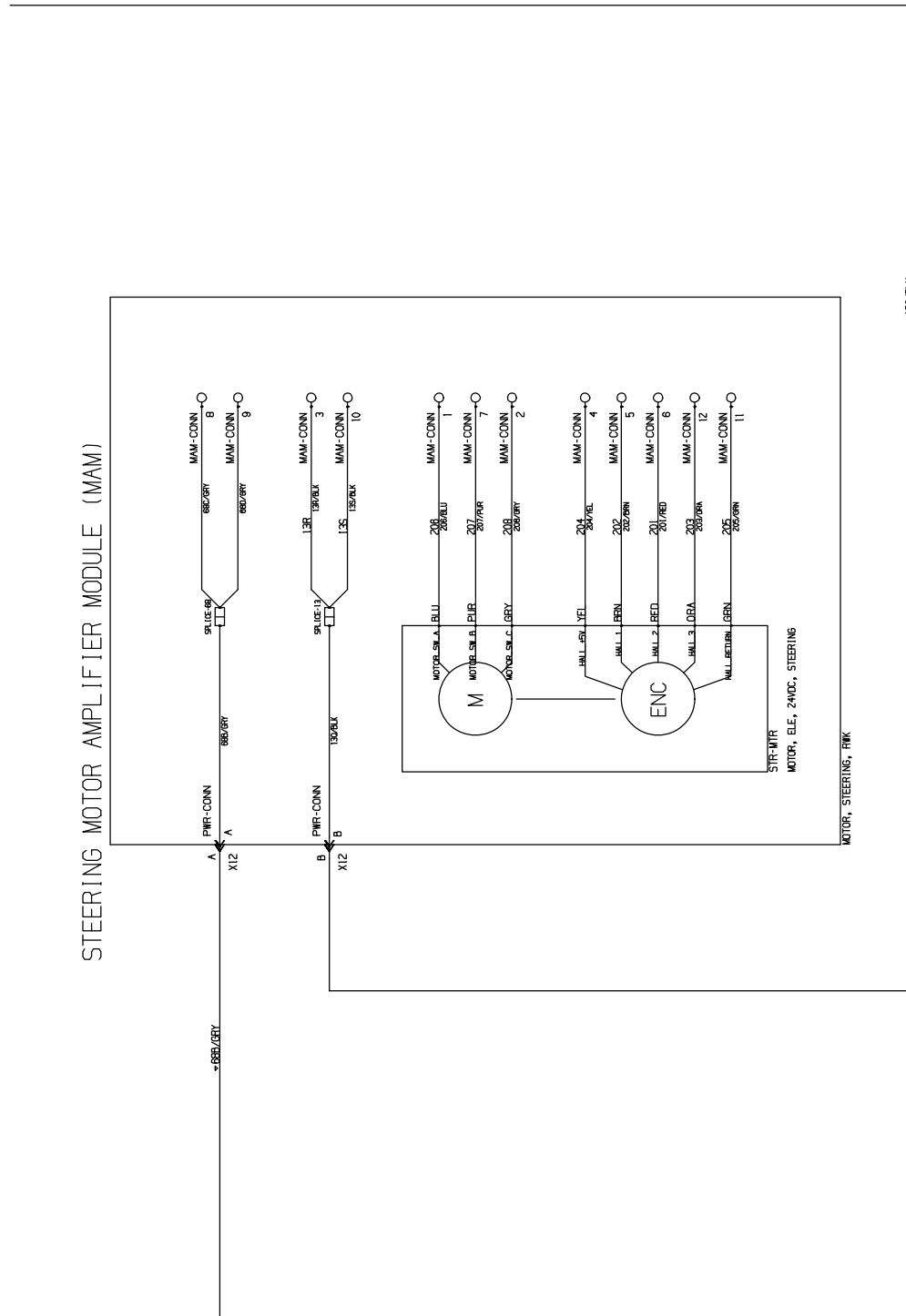

Fig. 25 – Electrical Schematic, Standard

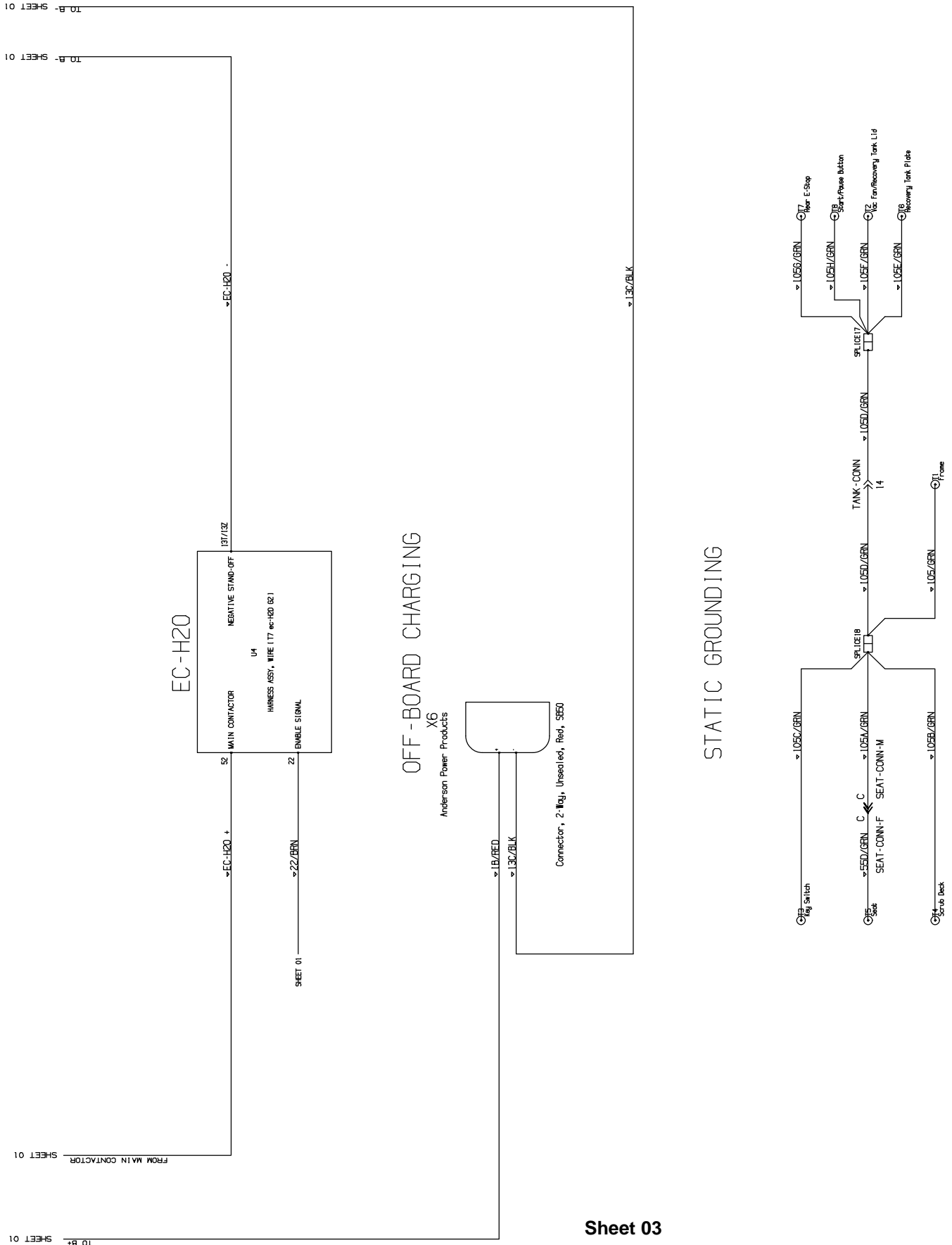

Fig. 26 - Wire Harnesses Group

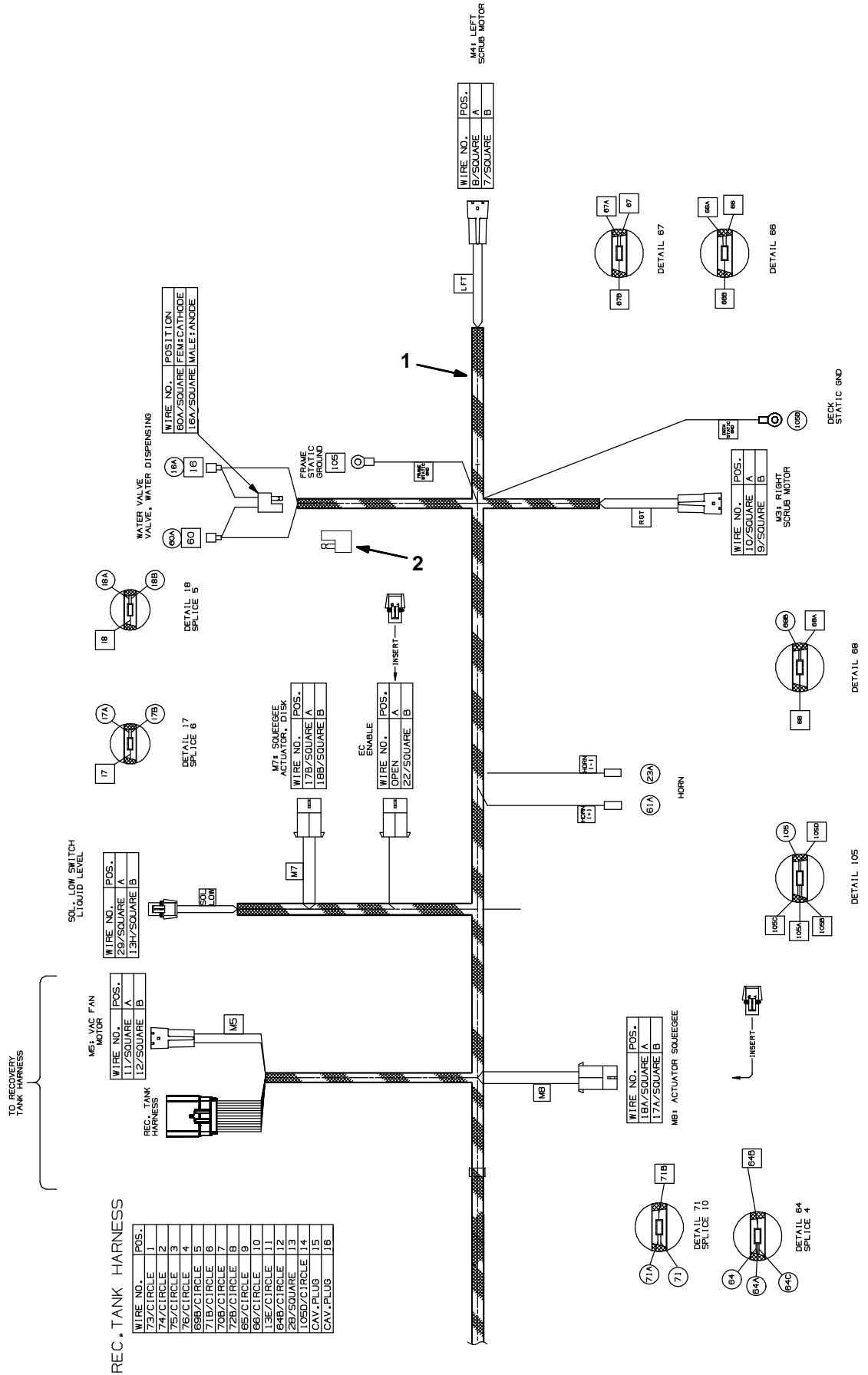

Fig. 26 - Wire Harness Group

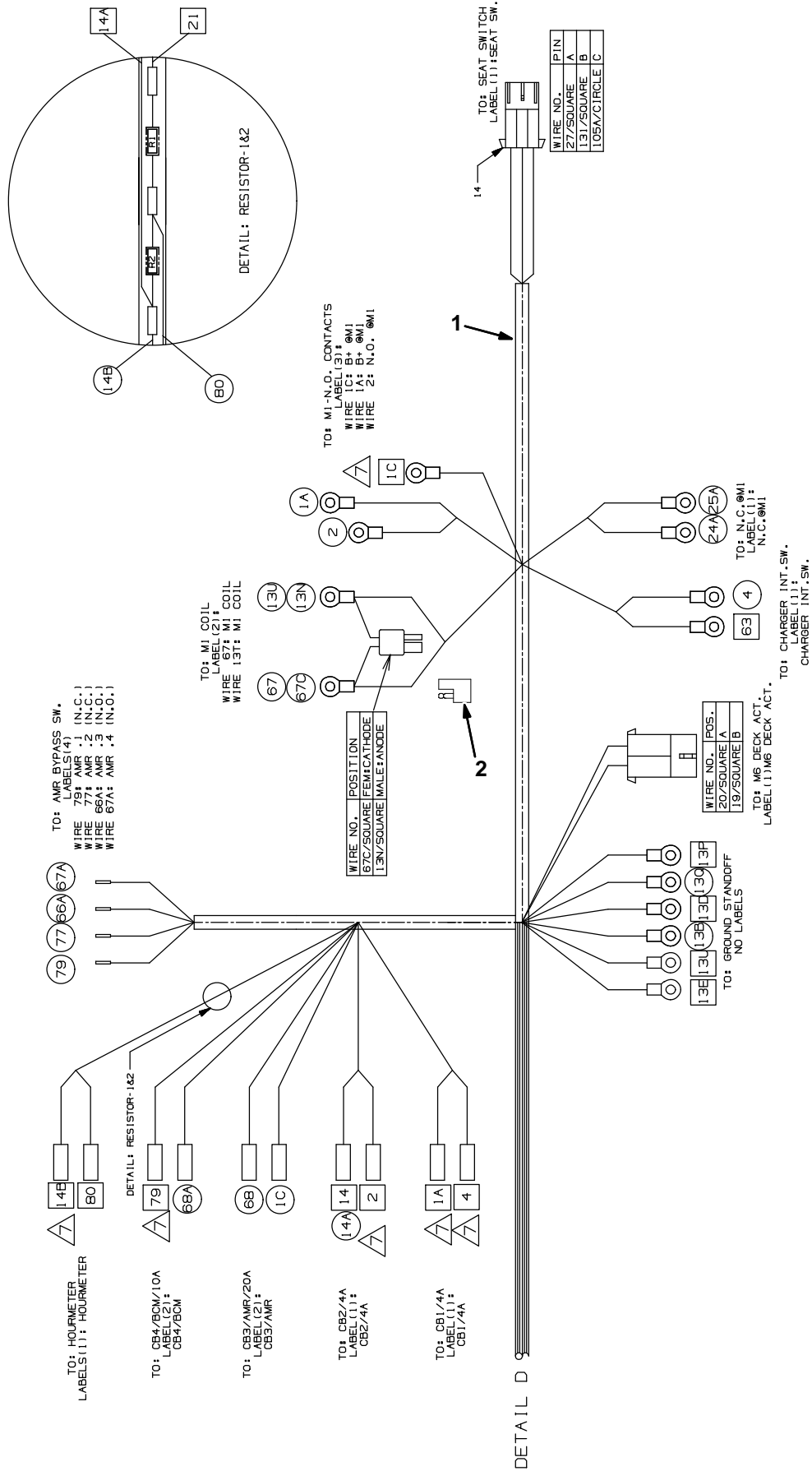
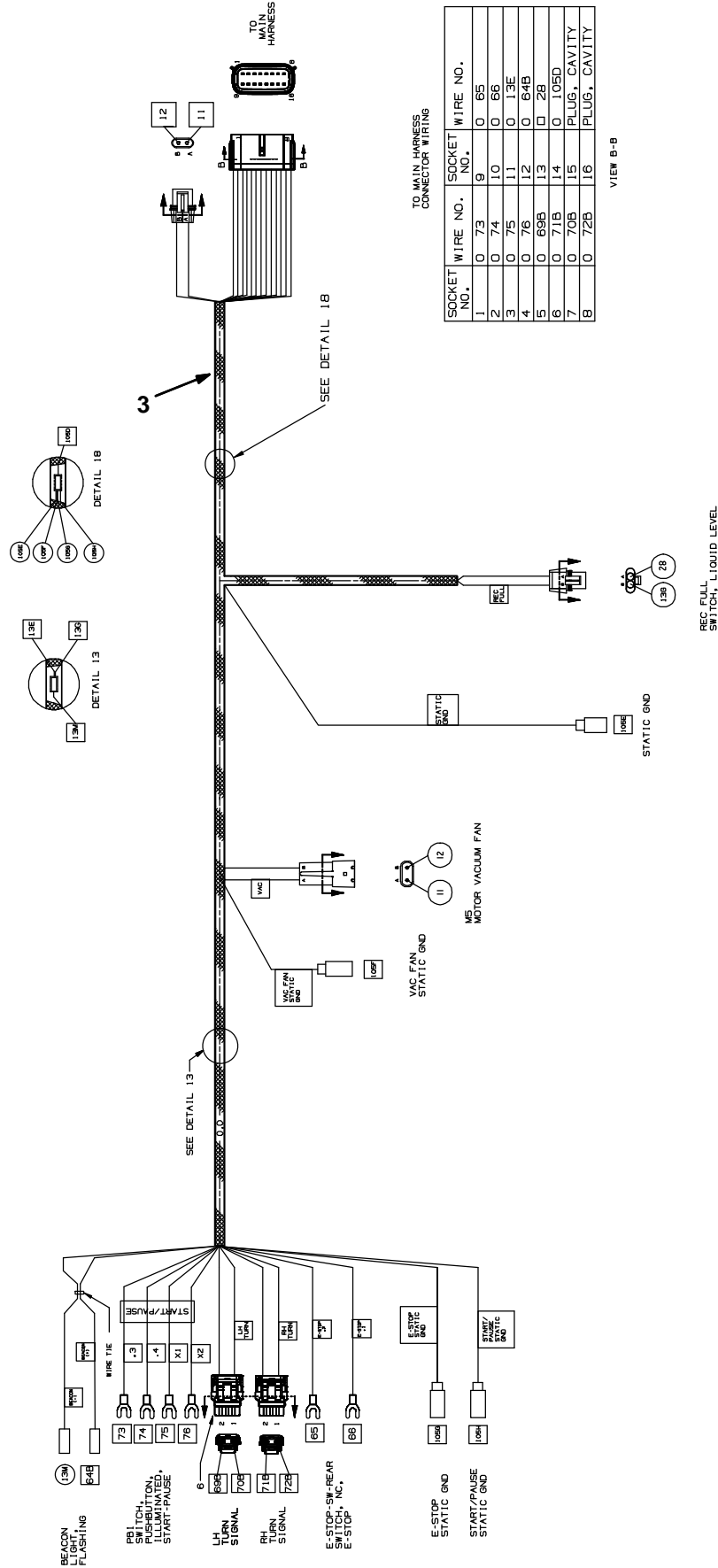

Fig. 26 - Wire Harnesses Group



1076447

Fig. 26 – Wire Harnesses Group

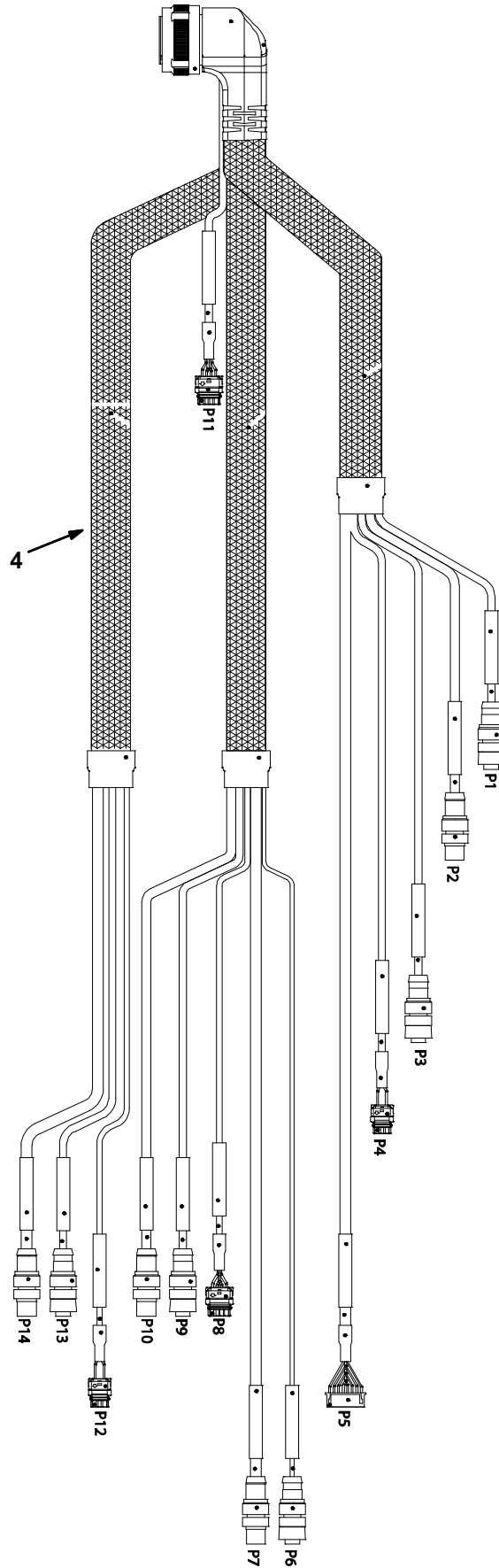
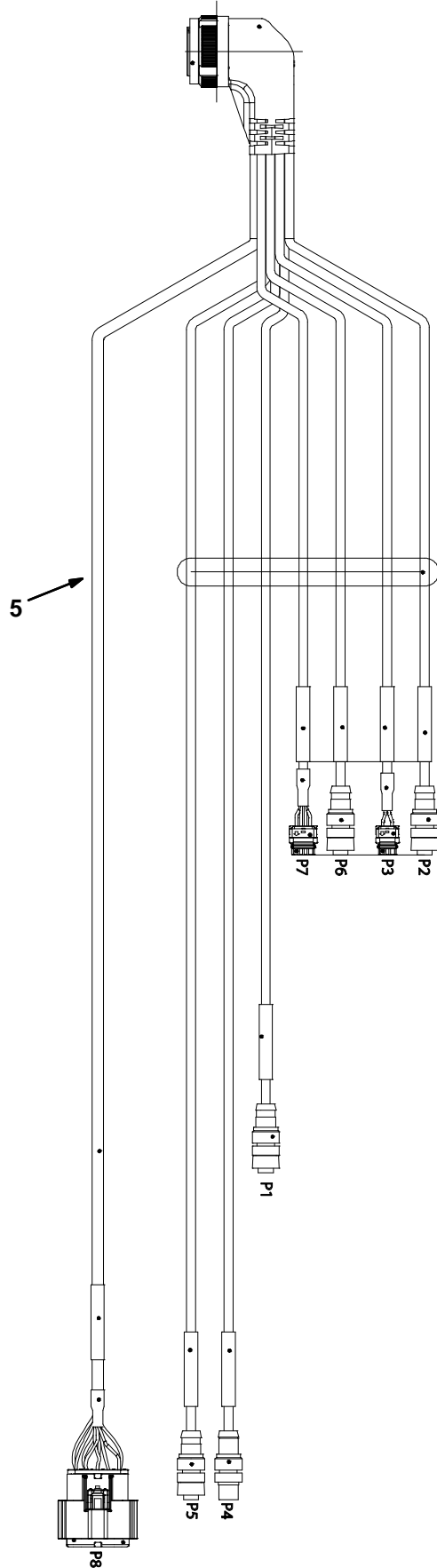
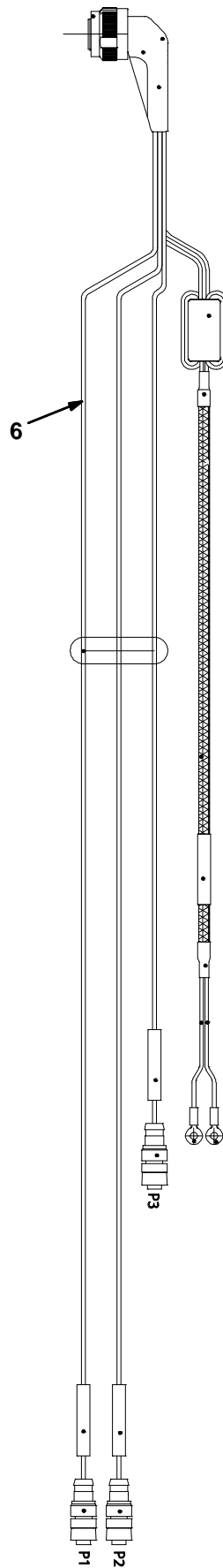

Fig. 26 – Wire Harness Group



1042298

Fig. 26 – Wire Harnesses Group



1242299

Fig. 26 – Wire Harnesses Group

Ref.	Part No.	Serial Number	Description	Qty.
1	1076446	(10000000–) Harness, Ele, Main	1
2	222290	(10000000–) Diode, Ele, Plug	2
3	1076447	(10000000–) Harness, Ele, Tank	1
4	9018610*	(10000000–) Harness, Amr, Upper, Afmkt	1
5	9018611*	(10000000–) Harness, Amr, Lower, Afmkt	1
6	9018612*	(10000000–) Harness, Amr, Power, Afmkt	1

* Requires Tennant *True* service or an authorized Tennant service provider.

Fig. 27 – Label Group

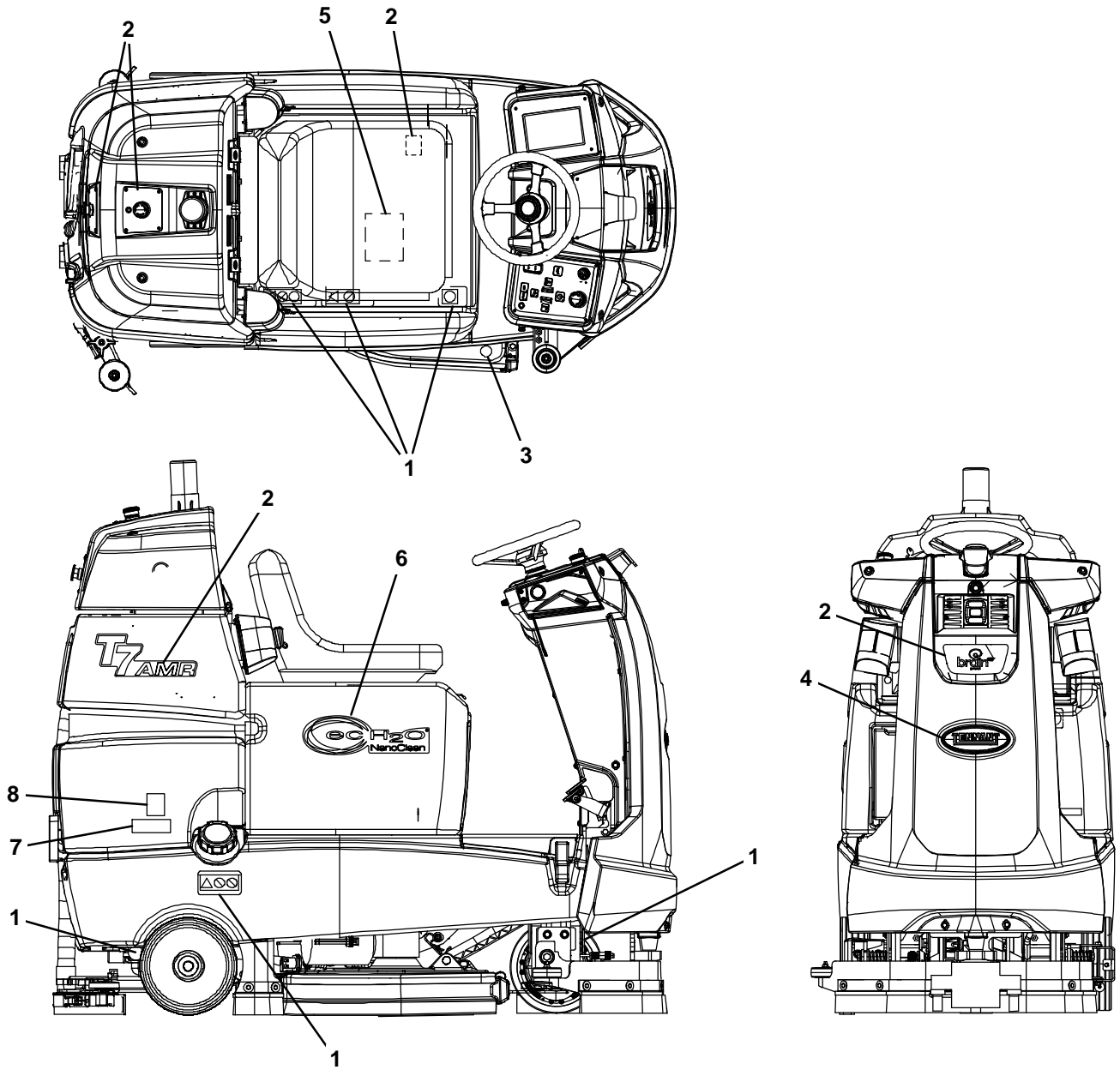

356902

Ref.	Part No.	Serial Number	Description	Qty.
1	1015167	(1000000–) Label Set, Info/Hzrd	1
1	1019186	(1000000–) Label Set, Info/Hzrd, Tj [T7] (Japan)	1
2	1244157	(1000000–) Label Set, Info/Hzrd, Pyc [T7Amr]	1
3	1030507	(1000000–) Label, Warning, 2x2 [No Step]	1
4	1204077	(1000000–) Nameplate, Tennant, Domed	1
5	1026686	(1000000–) Label, Hzrd, Battery, Connections	1
6	1216520	(1000000–) Label, Logo [ecH20 Nano]	2
7	1050003	(1000000–) Label [User, Attention, ec–H20]	1
8	1068925	(1000000–) Label, Do Not Add Detergent [ec–H20]	1

SECTION 3

Contents	Page
Fig. 1 – ec-H2O NanoClean Group, Disc Scrub Head	3-2
Fig. 2 – HydroLinkR Battery Watering System Kit	3-4
Fig. 3 – Documentation Group	3-5

Fig. 1 – ec-H2O NanoClean Group, Disc Scrub Head

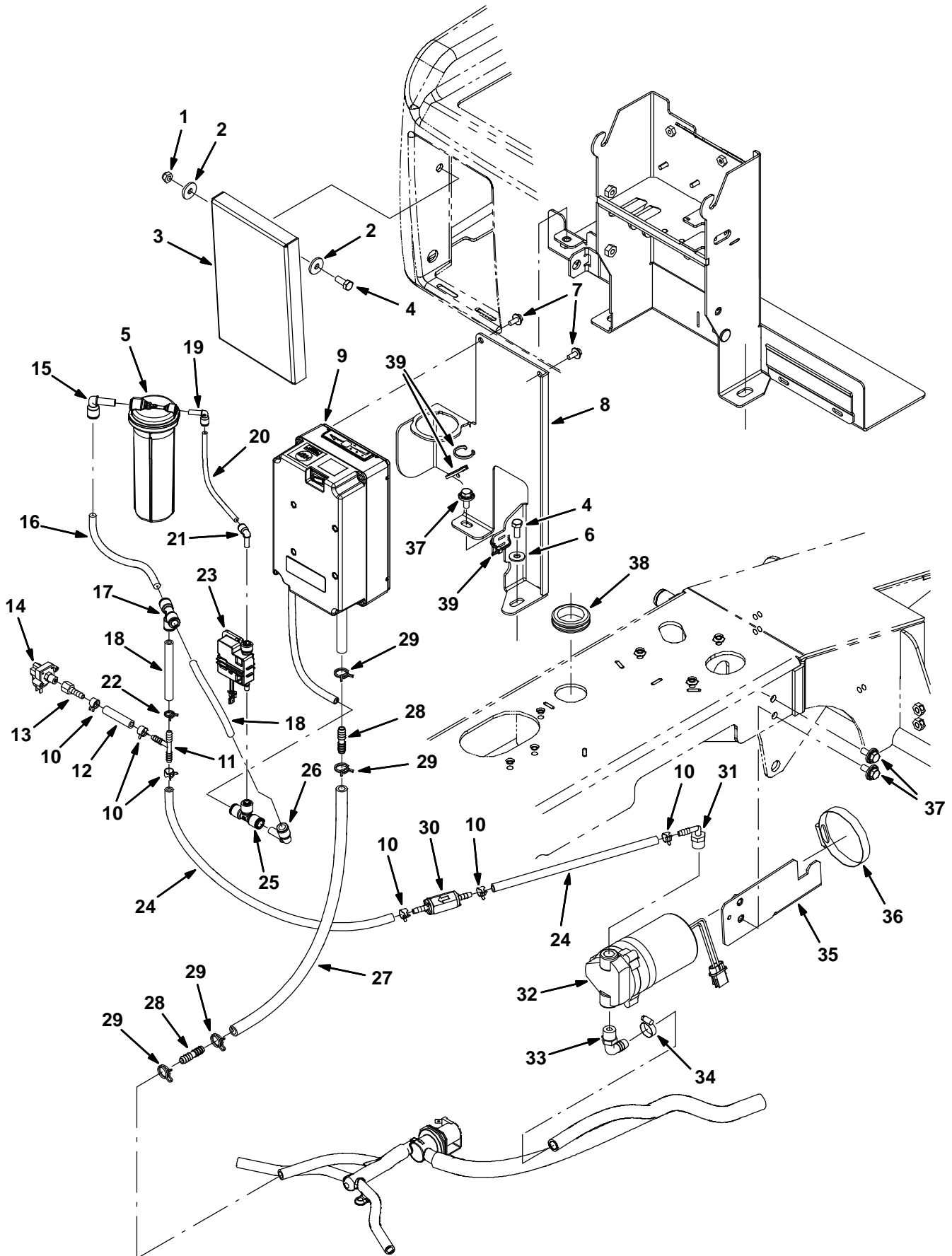

Fig. 1 – ec-H2O NanoClean Group, Disc Scrub Head

Ref.	Part No.	Serial Number	Description	Qty.	
1	08713	(10000000–) Nut, Hex, Lock, M8 X 1.25, NI, Ss	2	
2	1017218	(10000000–) Washer, Flat, 0.32b 1.00d .12, Ss	4	
3	1051138	(10000000–) Bracket, Cover, Fast Opng [T7 Ec–H2o]	1	
4	09740	(10000000–) Screw, Hex, M8 X 1.25 X 20, Ss	3	
5	9013646	(10000000–) Cartridge, Ec–H2o Nanoclean Wcm, 270ml	1	
6	01685	(10000000–) Washer, Flat, 0.38b 0.88d .08, Ss	1	
7	1034731	(10000000–) Screw, Hex, M6 X 1.00 X 16, Ss, Sems	2	
8	1216192	(10000000–) Bracket, Module, Ec–H20 [T7]	1	
9	9018615*	(10000000–) Module Kit, Replmt Amr [Ec–H2o, B 02] (See Breakdowns)	1	
10	603654	(10000000–) Clamp, Hose, Ear, .44d [Ctb]	6	
11	150713	(10000000–) Fitting, Plstc, Tee, Bm04/Bm04/Bm04	1	
12	575523000	(10000000–) Hose, Pvc, Brd, 0.25id 0.44od 043.5l,Clr	1	
13	150520	(10000000–) Fitting, Brs, Str, Bm04/Pf02	1	
14	1044415	(10000000–) Switch, Press, 20psi, Pm02	1	
15	1215186	(10000000–) Fitting, Plstc, E90, Qf06/Qm06	1	
16	9014146	(10000000–) Hose, Afmkt, Pvc, 0.06id .38od, 05ft	1	
17	1212573	(10000000–) Fitting, Plstc, Tee, Qf06/Qf06/Qf06	1	
18	1014987	(10000000–) Hose, Afmkt, Pvc, Clr, 0.25id, 01ft	1	
19	1214339	(10000000–) Fitting, Plstc, E90, Qfo4/Qm04	1	
20	9014147	(10000000–) Hose, Afmkt, Pvc, 0.06id .25od, 05ft	1	
21	1214339	(10000000–) Fitting, Plstc, E90, Qfo4/Qm04	1	
22	613735	(10000000–) Clamp, Hose, Wir, .40 – .42, Yel	1	
23	1216973	(10000000–) Pump Assy, Dispenser	1	
24	9014210	(10000000–) Hose, Afmkt, Pvc, Brd .25id .44od, 05ft	1	
25	1212855	(10000000–) Fitting, Plstc, Tee, Qf04/Qf06/Qf06	1	
26	1215186	(10000000–) Fitting, Plstc, E90, Qf06/Qm06	1	
27	1006400	(10000000–) Hose, Afmkt, Pvc, Brd, 0.38id, 03ft, Clr	1	
28	20950	(10000000–) Fitting, Plstc, Str, Bm06/Bm06	2	
29	607775	(10000000–) Clamp, Hose, Wir, .63 – .66, Blk	4	
30	1216879	(10000000–) Valve, Check, 0005psi Bm04/Bm04	1	
31	150417	(10000000–) Fitting, Plstc, E90, Bm04/Pm06	1	
▽	32	1042495	(10000000–) Pump, Soltn, Ele, 24vdc, 35psi	1
▲	9004759	(10000000–) Pump Kit, Head, Soltn [Ec–H2o]	1	
▲	78950	(10000000–) Connector, Fem, 2cav, Mp280 Sealed	1	
▲	78951	(10000000–) Terminal, Fem, Mp280, Sealed, 18–16ga	1	
▲	10917	(10000000–) Seal, Wire, 14/16ga [Wp / Mp280 Sealed]37	1	
▲	78952	(10000000–) Lock, Secondary, 2cav, Mp280 Sealed	1	
33	64778	(10000000–) Fitting, Plstc, E90, Bm08/Pm06	1	
34	54333	(10000000–) Clamp, Hose, Wormdrive, 0.31–0.88d, .31w	1	
35	1014617	(10000000–) Bracket, Pump, Soltn	1	
36	43555	(10000000–) Clamp, Hose, Wormdrive, 2.50–3.50d, .50w	1	
37	1020341	(10000000–) Screw, Hex, M8 X 1.25 X 20, Ss, Sems	3	
38	10632–13	(10000000–) Grommet, Rbr, 1.50id, F/1.8h, .19 Matl	1	
39	130773	(10000000–) Tie, Cable, Nyl, 11.0l, .14w, 3.0 Max. D	3	

* Requires Tennant *True* service or an authorized Tennant service provider.

▽ Assembly

▲ Included in Assembly

Fig. 2 – HydroLink® Battery Watering System Kit

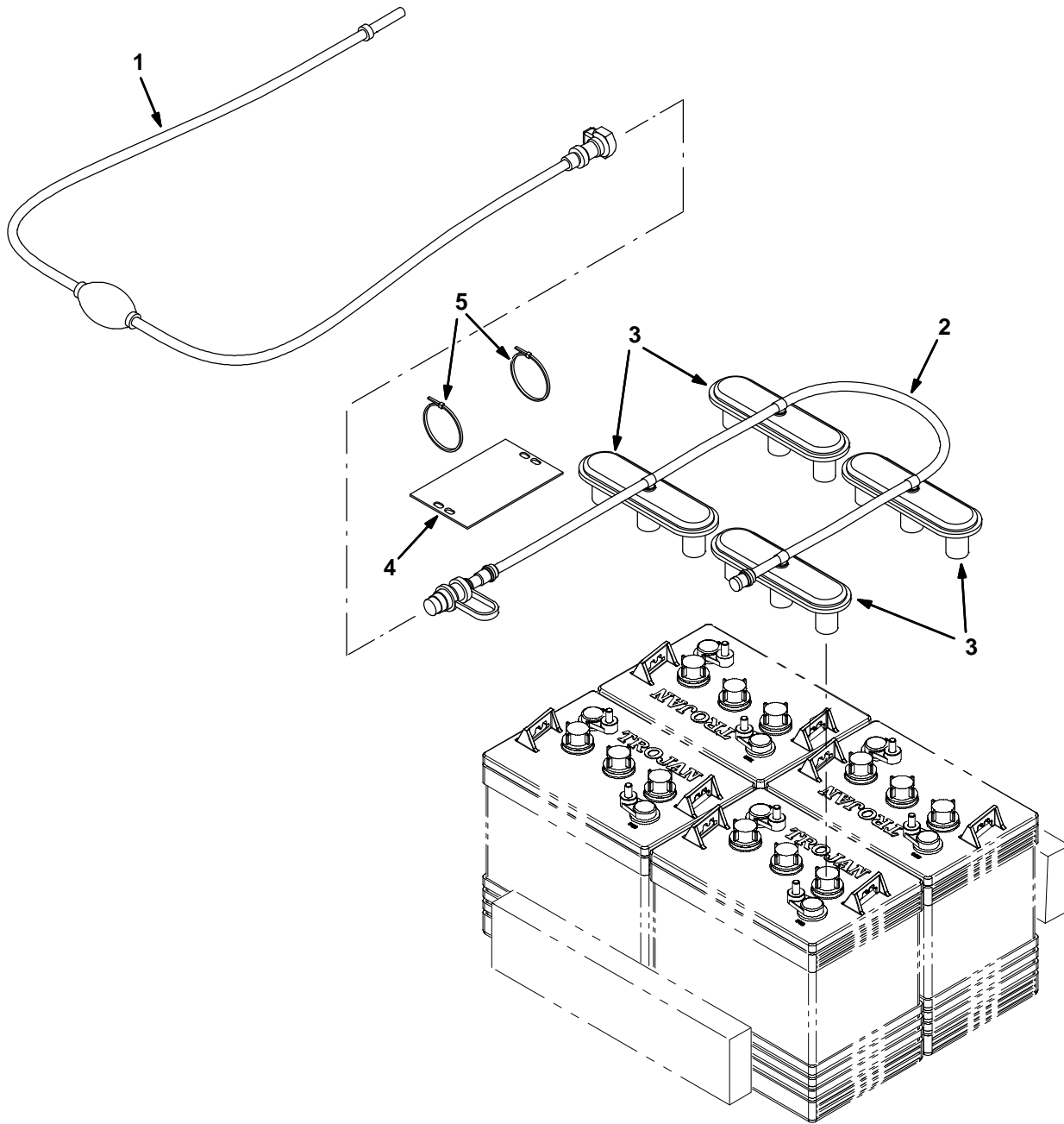

Ref.	Part No.	Serial Number	Description	Qty.
▽	9010300	(10000000–) Pump Kit, Fill, Battery,24vdc,Ci[Trojan]	1
▲	1 1058939	(10000000–) Pump Kit, Fill, Battery	1
▲	2 1070394	(10000000–) Tube, Water, Battery, 24vdc [Trojan]	1
▲	3 1204142	(10000000–) Cap, Fill, Battery [Trojan]	4
▲	4 1071084	(10000000–) Label, Tag, Battery [HydroLink Watering]	1
▲	5 130773	(10000000–) Tie, Cable, Nyl, 11.0l, .14w, 3.0 Max. D	2

*THIS KIT IS INTENDED FOR USE WITH TROJAN® LEAD ACID BATTERIES ONLY.

HYDROLINK® IS A REGISTERED TRADEMARK OF TROJAN® BATTERY COMPANY.

▽ Assembly

▲ Included in Assembly

Fig. 3 – Battery Charger

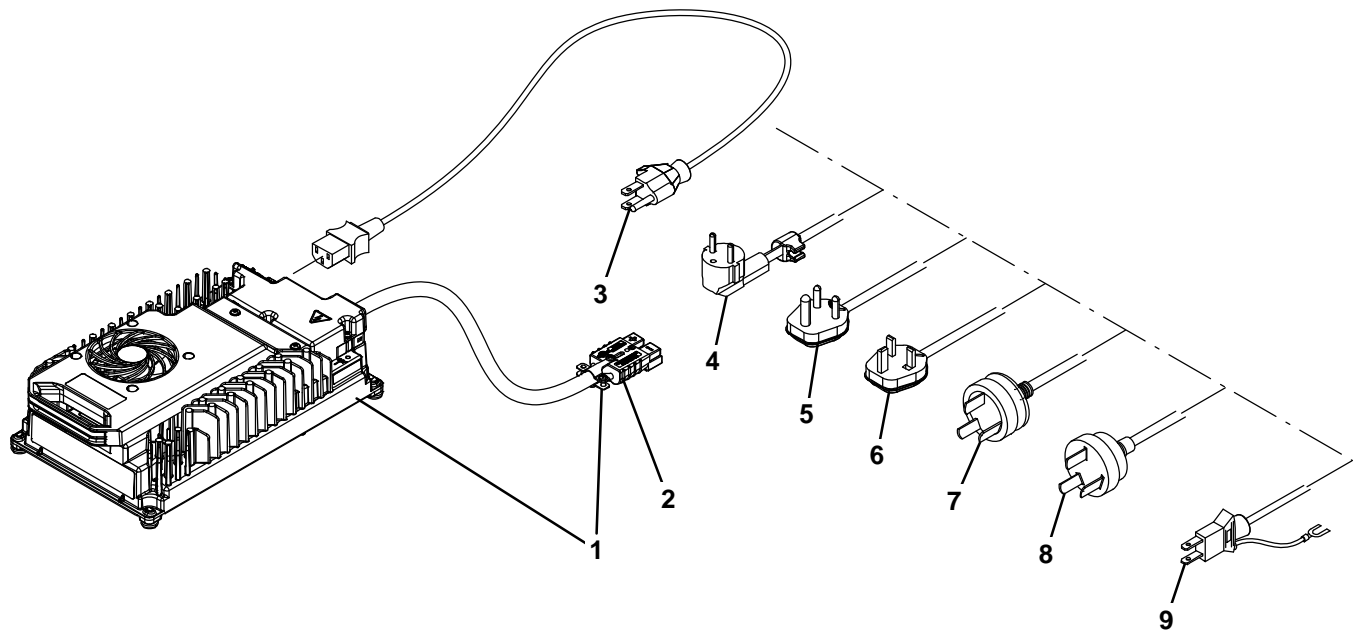

356925

Ref.	Part No.	Serial Number	Description	Qty.
▽	1	9018161	(10000000-) Charger Kit, Off Board	1
▲	2	605387	(10000000-) Connector, Anderson, 050a, Red [W/O Con]	1
	3	1025642	(10000000-) Cord, Power, 16/3, 15ft Blk [Us]	1
	4	1032849	(10000000-) Cord, Power, Blk [4.5meter, Ce]	1
	5	1048304	(10000000-) Cord, Power [4.5meter, India, S.Africa]	1
	6	1032820	(10000000-) Cord, Power, Blk [4.5meter, Uk]	1
	7	1026325	(10000000-) Cord, Power, 1.0mm2/3 Blk[2.5meter, Aus]	1
	8	1026330	(10000000-) Cord, Power, 1.0mm2 [2.5meter, China]	1
	9	1019426	(10000000-) Cord, Chrgr, Ele, Tj	1

▽ Assembly

▲ Included in Assembly

Fig. 4 – Documentation Group

Ref.	Part No.	Serial Number	Description	Qty.
9018134	(10000000–)	Manual, Oprtr [T7amr, En, Na]	1
9018135	(10000000–)	Manual, Oprtr [T7amr, Jp]	1
9018136	(10000000–)	Manual, Oprtr [T7amr, Es, Na]	1
9018137	(10000000–)	Manual, Oprtr [T7amr, Fr, Na]	1
9018138	(10000000–)	Process Guide – English	1
9018139	(10000000–)	Process Guide – Japanese	1
9018140	(10000000–)	Process Guide – Spanish	1
9018141	(10000000–)	Process Guide – French	1
9018142	(10000000–)	Manual, Parts [T7amr, Na/Jp]	1
9018143	(10000000–)	Manual, Service [T7amr, En]	1



To view, print, order, download the latest Parts manual, other language Operator manuals, and Use and Care Guides (wall charts), visit:

www.tennantco.com/manual

SECTION 4

Contents	Page
Fig. 1 – Steering Control Breakdown, 1019724 . .	4-2
Fig. 2 – ec-H2O NanoClean Module Breakdown, 9018615	4-4
Fig. 3 – Vacuum Fan Motor Breakdown, 1039763	4-6
Fig. 4 – Vacuum Fan Motor Breakdown, 1021064	4-8

Fig. 1 – Steering Control Breakdown, 1019724

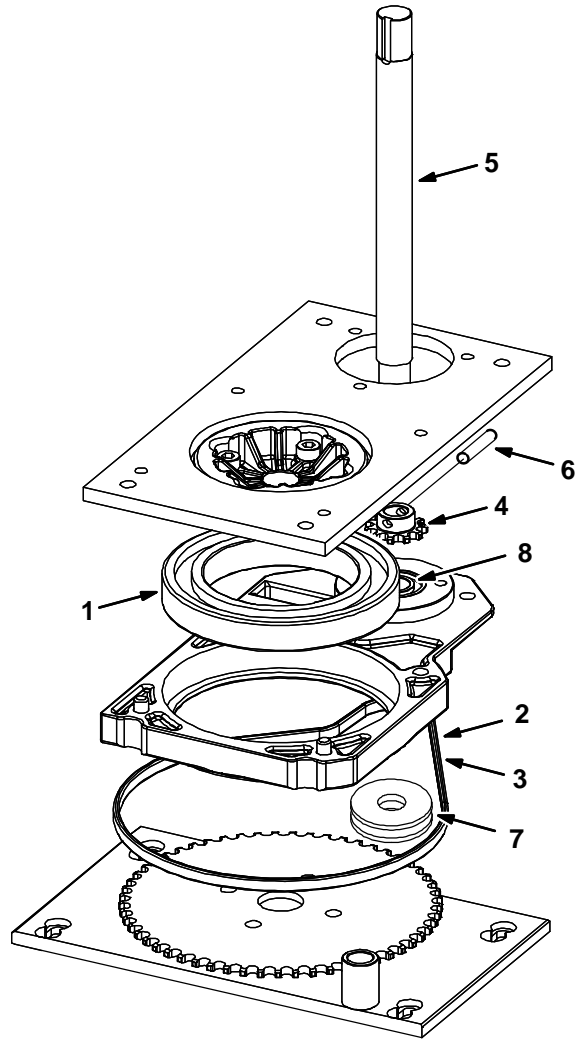

Fig. 1 – Steering Control Breakdown, 1019724

	Ref.	Part No.	Serial Number	Description	Qty.
▽		1019724	(10000000–) Steer–Control Assy, Wheel Drive	1
▲	1	372874	(10000000–) Bearing, Steering	1
▲	2	372875	(10000000–) Chain, Steering	1
▲	3	372876	(10000000–) Link, Master	1
▲	4	372881	(10000000–) Sprocket	1
▲	5	1029229	(10000000–) Shaft, Steering	1
▲	6	1038313	(10000000–) Pin, Roll, 06Mm X 28MmL	1
▲	7	1043371	(10000000–) Pulley, Tens [T7/R14 Steering Assy]	1
▲	8	9008719	(10000000–) Vr, Bearing [6003 2rs]	2

▽ Assembly

▲ Included in Assembly

Fig. 2 – ec-H2O NanoClean Module Breakdown, 9018615

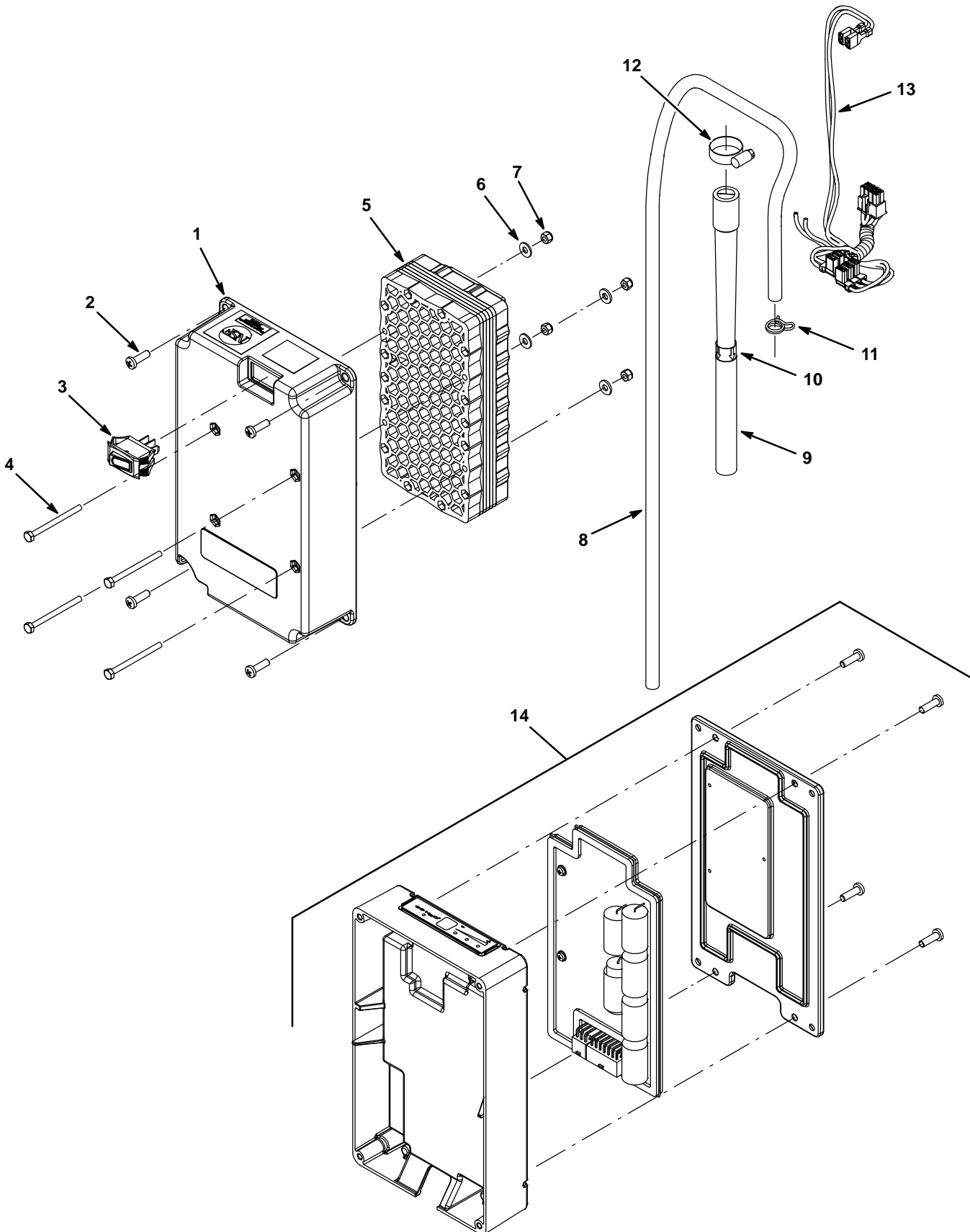

Fig. 2 – ec-H2O NanoClean Module Breakdown, 9018615

Ref.	Part No.	Serial Number	Description	Qty.
▽	9018615	(10000000–) Module Kit, Replmt, Amr [Ec–H2o, B 02]	1
▲▽	9014126	(10000000–) Ec–H2o Nc Kit [Module B, Plumbing]	1
▲▲	1 1208823	(10000000–) Housing, Module, Upper, Ec–H2o	1
▲▲	2 1015506	(10000000–) Screw, Pan, Phl, M5 X 16, Tcut [Plastic]	4
▲▲	3 1044393	(10000000–) Switch, Rocker, Spst, Mom	1
▲▲	4 32509	(10000000–) Screw, Hex, M4 X 0.70 X 50, Ss	4
▲▲	5 1208164	(10000000–) Electrode, 5 Plate, High Flow	1
▲▲	6 41579	(10000000–) Washer, Flat, 08, Ss	4
▲▲	7 33932	(10000000–) Nut, Hex, Lock, M4 X 0.70, NI, Ss	4
▲▲	8 1006415	(10000000–) Hose, Afmkt, Pvc, Clr, 0.25id, 03ft	1
▲▲	9 1208526	(10000000–) Hose, Molded, Bm08/Bm06	1
▲▲	10 1049637	(10000000–) Label, Direction [Ec–H2o]	1
▲▲	11 613735	(10000000–) Clamp, Hose, Wir, .40 – .42, Yel	1
▲▲	12 54333	(10000000–) Clamp, Hose, Wormdrive, 0.31–0.88d, .31w	1
▲▲	13 1073286	(10000000–) Harness, Ele, Module B2 [Ec–H2o]	1
▲	14 9018614*	(10000000–) Controller Kit, Replmt, Amr [Ec–H2o Nc]	1

* Requires Tennant *True* service or an authorized Tennant service provider.

▽ Assembly

▲ Included in Assembly

Fig. 3 – Vacuum Fan Motor Breakdown, 1039763

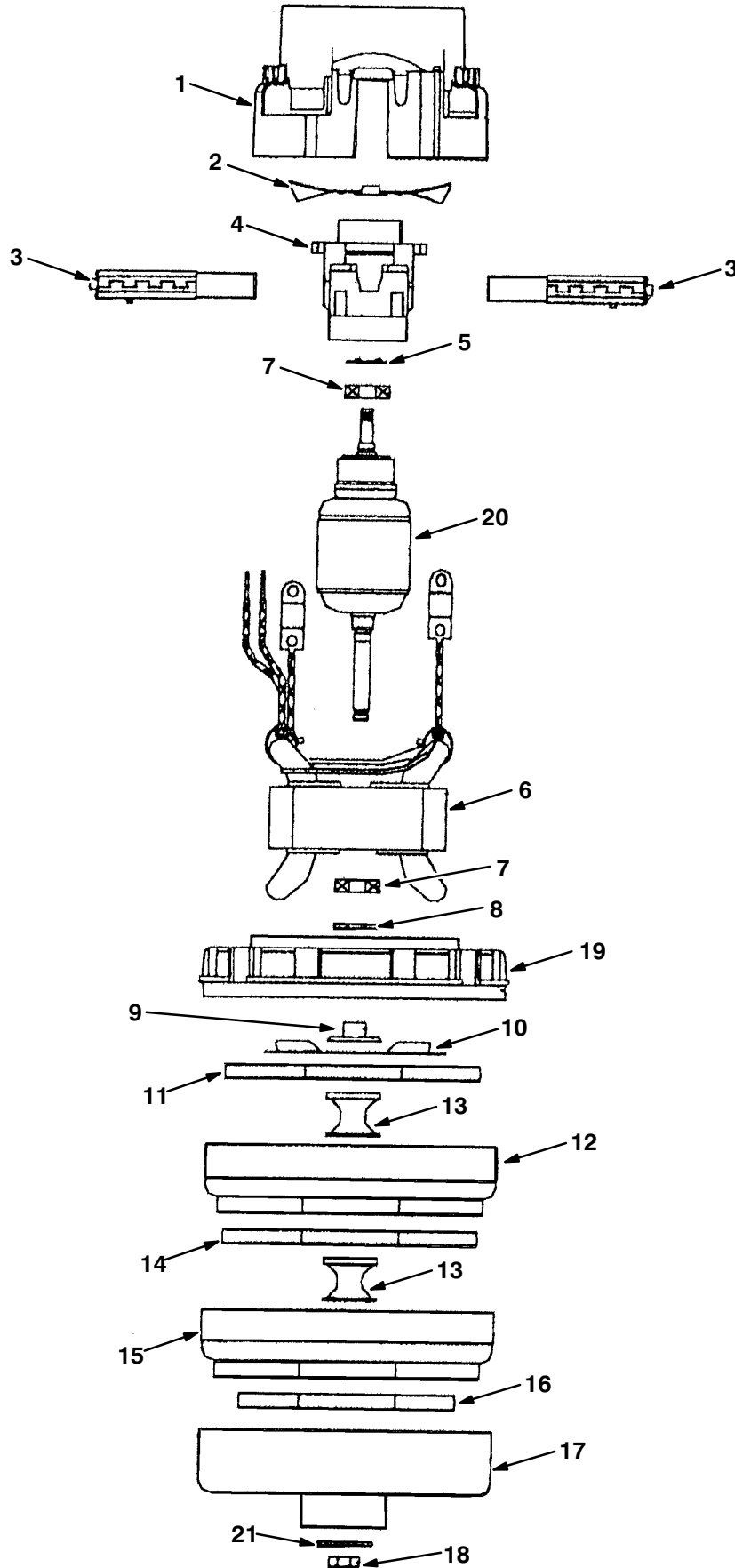

Fig. 3 – Vacuum Fan Motor Breakdown, 1039763

Ref.	Part No.	Serial Number	Description	Qty.
▽	1039763	(10000000–) Fan, Vacuum, 5.7D, 024Vdc, 3 Stage [Bpp]	1
▲	1 398511	(10000000–) Housing	1
▲	2 398512	(10000000–) Fan	1
▲	3 372883	(10000000–) Brush Kit, Motor, Ele	1
▲	4 398514	(10000000–) Bracket	1
▲	5 01856	(10000000–) Spring, Brg, Motor, Vacfan	1
▲	6 372885	(10000000–) Commutator	1
▲	7 01837	(10000000–) Bearing, Motor, Vacfan	2
▲	8 372886	(10000000–) Washer	1
▲	9 398516	(10000000–) Spacer	1
▲	10 01971	(10000000–) Impeller, Vacfan	1
▲	11 372888	(10000000–) Impeller, Fan	1
▲	12 60387	(10000000–) Fan	1
▲	13 398517	(10000000–) Spacer	2
▲	14 18628	(10000000–) Impeller, Vacfan	1
▲	15 61297	(10000000–) Housing, Impeller, Vacfan	1
▲	16 372889	(10000000–) Impeller, Fan	1
▲	17 372890	(10000000–) Shell, Fan	1
▲	18 37929	(10000000–) Nut, Impeller, Vacfan	1
▲	19 372887	(10000000–) Bracket, End, Fan	1
▲	20 372884	(10000000–) Armature	1
▲	21 378983	(10000000–) Washer	1
▲	223264	(10000000–) Seal, Rbr, Clsd, 0.25th, 5.8d 03.3h	1
▲	10925	(10000000–) Connector, Fem, 2cav [Mp630 Sealed]	1
▲	24537	(10000000–) Terminal, Fem, 10/12ga [Mp630 P2s]	2

▽ Assembly

▲ Included in Assembly

Fig. 4 – Vacuum Fan Motor Breakdown, 1021064

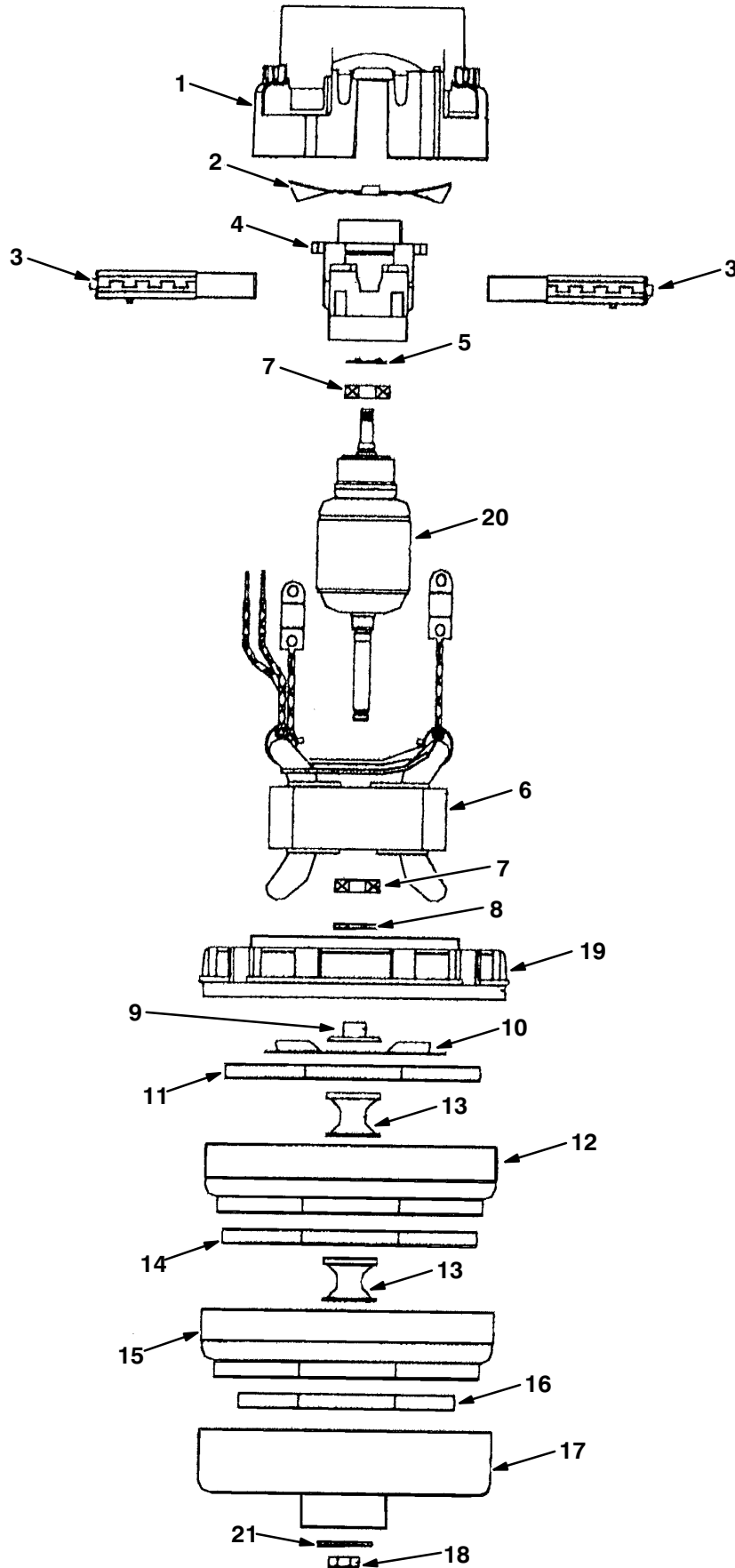

Fig. 4 – Vacuum Fan Motor Breakdown, 1021064

Ref.	Part No.	Serial Number	Description	Qty.
▽	1021064	(10000000–) Fan, Vacuum, 5.7, 3s 24v Bpt (Australian Model)	1
▲	1 398511	(10000000–) Housing	1
▲	2 398512	(10000000–) Fan	1
▲	3 372883	(10000000–) Brush Kit, Motor, Ele	1
▲	4 398514	(10000000–) Bracket	1
▲	5 01856	(10000000–) Spring, Brg, Motor, Vacfan	1
▲	6 372885	(10000000–) Commutator	1
▲	7 01837	(10000000–) Bearing, Motor, Vacfan	2
▲	8 372886	(10000000–) Washer	1
▲	9 398516	(10000000–) Spacer	1
▲	10 01971	(10000000–) Impeller, Vacfan	1
▲	11 372888	(10000000–) Impeller, Fan	1
▲	12 60387	(10000000–) Fan	1
▲	13 398517	(10000000–) Spacer	2
▲	14 18628	(10000000–) Impeller, Vacfan	1
▲	15 61297	(10000000–) Housing, Impeller, Vacfan	1
▲	16 372889	(10000000–) Impeller, Fan	1
▲	17 372890	(10000000–) Shell, Fan	1
▲	18 37929	(10000000–) Nut, Impeller, Vacfan	1
▲	19 372887	(10000000–) Bracket, End, Fan	1
▲	20 372884	(10000000–) Armature	1
▲	21 378983	(10000000–) Washer	1
▲	223264	(10000000–) Seal, Rbr, Clsd, 0.25th, 5.8d 03.3h	1
▲	10925	(10000000–) Connector, Fem, 2cav [Mp630 Sealed]	1
▲	24537	(10000000–) Terminal, Fem, 10/12ga [Mp630 P2s]	2

▽ Assembly

▲ Included in Assembly

