



Innovative Cleaning Systems
www.tornadovac.com

T 12 / 1 C A N I S T E R D R Y V A C U U M



T 12 / 1

T 12 / 1 CANISTER DRY VACUUM

The quietest, most powerful canister dry vacuum in its class, with built-in HEPA filtration as standard

The all-new T12/1 is the most powerful, compact and efficient Dry Canister Vacuum available in its class today. It was designed to accommodate noise sensitive environments such as hotels, restaurants, retail outlets, offices and schools, where silent, all day cleaning is a necessity. At just 61 dB, the T12/1 is whisper quiet in its operation. Weighing in at only 14 lbs the T12/1 is highly maneuverable and can be lifted with ease. Its streamlined profile makes storage a breeze.

The 6-stage filtration system incorporates a three-layered fleece filter bag, a permanent main filter and motor protection filter, plus a built-in HEPA exhaust air filter for optimum recovery. This standard HEPA filtration system (99.97% efficiency at 0.3 microns) is designed to contain fine particulate and dust,



INNOVATIVE STORAGE FOR THE WAND

The T12/1 features a unique "parking spot" for the wand when not in use. Simply place the wand in this convenient spot whenever downtime is involved.



OPERATOR FRIENDLY AND QUIET

The T12/1 glides smoothly over the floor wherever the operator takes it. It's ergonomic design is comfortable and easy to use.

The T12/1 is extremely quiet, less than 61dB, ideal for noise sensitive environments. 8' hose and wand come standard with the unit.



EASY ACTIVATION

With operator comfort and convenience in mind, the T12/1 incorporates a large, easy to access on/off foot pedal.



MAXIMUM POWER FILTRATION

The T12/1 incorporates a 6 stage filtration system that includes; a three-layered fleece filter bag, a permanent main filter and motor protection filter, plus a built-in HEPA exhaust filter for optimum recovery.



substantially improving indoor air quality. The T 12/1 is therefore strongly sought after by the healthcare and educational industries. The fleece filter bags are made from a tear-proof material, reducing the vacuum's running and maintenance costs. The three dimensional fiber pattern cannot be damaged by paper-clips, sand or gravel, and holds up to three times as much dust as a regular paper filter bag.

The T 12/1 was specifically designed around the user. The unit is comfortable to operate, even over an extended period of time. A new ergonomically designed handle provides the utmost in operator comfort. The unit is light to transport, and includes a large foot-operated switch and dedicated "parking spot" for the wand when not in use. When the job is complete, an integrated mount allows the user to store the power cord quickly and easily.

It's everything you could possibly want in a Dry Canister Vacuum.

PRODUCT SPECIFICATIONS	
MODEL	T 12/1
CATALOG NUMBER	93240
VAC MOTOR	1.74 HP
CFM	130 CFM
CAPACITY	3.17 gal/12 liters
SOUND LEVEL	61 dB
POWER CORD	40'
POWER	115V
WEIGHT	14 lbs
DIMENSIONS	16" x 12" x 13"
STANDARD ACCESSORIES AND REPLACEMENT ITEMS	
8' EXTENSION HOSE	K44407740
FLEECE FILTER BAGS - 10 PACK (1 BAG INCLUDED WITH UNIT)	K69043150
HEPA FILTER	K64148010
HARD FLOOR TOOL	K69066960
ALUMINUM WAND	K69038500
OPTIONAL ACCESSORIES AND ATTACHMENTS	
TURBO UPHOLSTERY TOOL	K28601130
TELESCOPIC WAND	K28601200
TOOL SET (CREVICE/ROUND/UPHOLSTERY TOOLS)	K58601430
FLEECE FILTER BAG - 300 PACK	K69043090
PAPER FILTER BAG - 10 PACK (USED IN LIEU OF FLEECE BAG)	K69043120



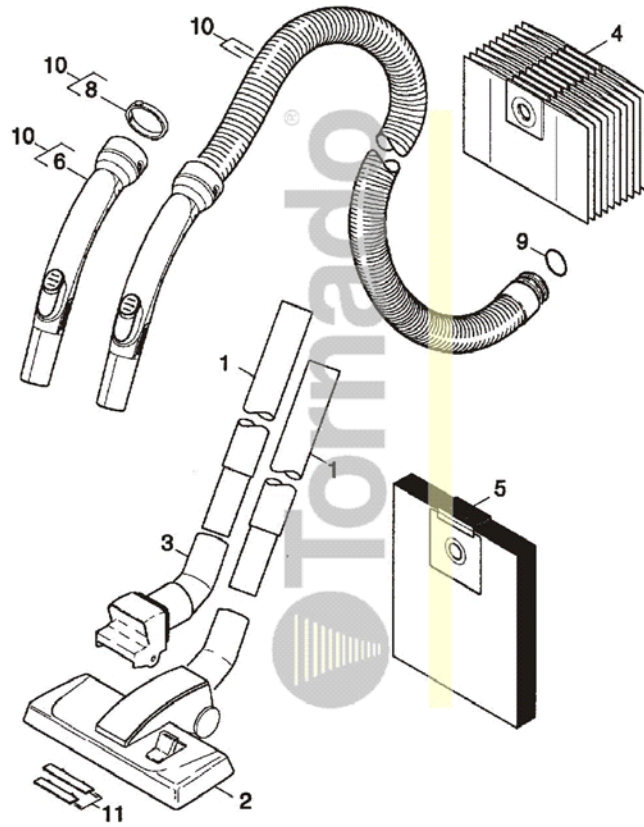

No.	Number	Qty	Description
1	K69038500	2	METAL WAND 1-PC 2 REQD
2	K69066960	1	HARD FLOOR TOOL REPLACES K69066020
3	K69066970	1	JOINT
4	K69043120	1	FILTER BAG-PAPER (10 PK)
5	K69043150	1	FILTER BAG 12/1 FLEECE 10 PER PACK
6	K44080510	1	ELBOW
8	K50317030	1	TENSION RING T 191 TORNADO -USA
9	K63631820	1	GASKET 30 2 X 3 0
10	K44407740	1	SUCTION HOSE
11	K69066980	1	THREAD CLIPPER

No.	Number	Qty	Description
1	K40705300	1	TANK
2	K53430220	1	SPRING CLIP
3	K64357070	2	CASTOR
4	K45152520	1	WHEEL
5	K73030860	2	SCREW 5X30 -10.9-A2R (IN6RD)

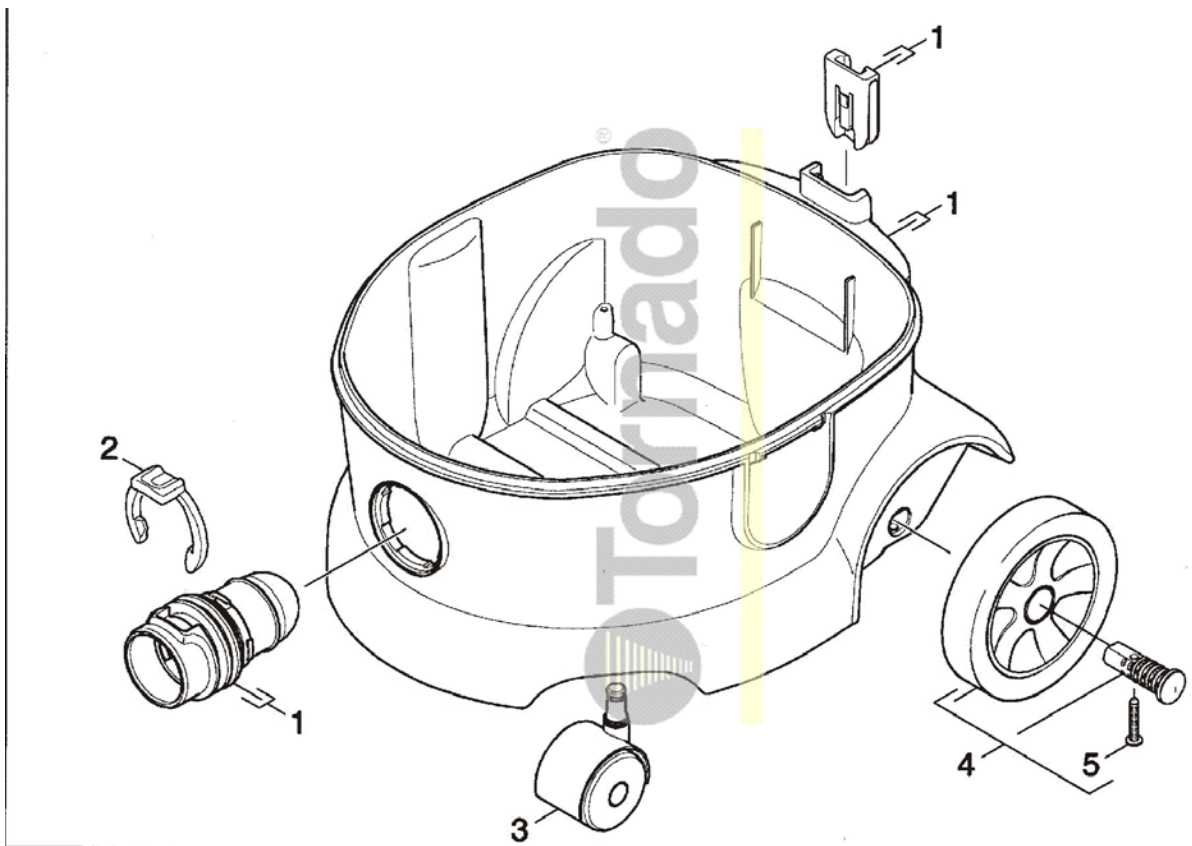

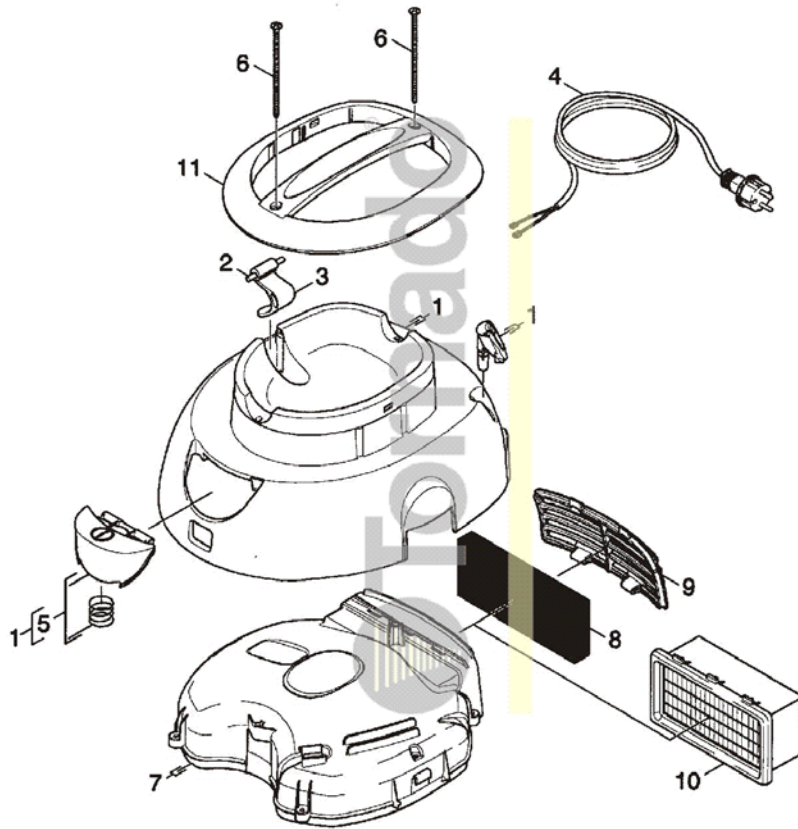

No.	Number	Qty	Description	Sell 0	Cost 0
▶ 1	K40690010	1	COVER	\$114.91	\$0.00
2	K73140320	1	STRAIGHT PIN 5M6 X 50	\$3.49	\$0.00
3	K50325970	1	CATCH FOR CABLE	\$4.52	\$0.00
4	K66475470	1	POWER CABLE	\$47.01	\$0.00
5	K43240190	1	CALIPER	\$26.12	\$0.00
6	K73031550	2	SCREW 5 X 100	\$3.20	\$0.00
7	K46920310	1	AIR CIRCULATION	\$62.68	\$0.00
8	K64148020	1	FILTER	\$15.68	\$0.00
9	K50325690	1	GRATE	\$12.18	\$0.00
10	K64148010	1	FILTER HEPA	\$66.68	\$0.00
11	K53217270	1	HANDLE T12/1	\$23.01	\$0.00

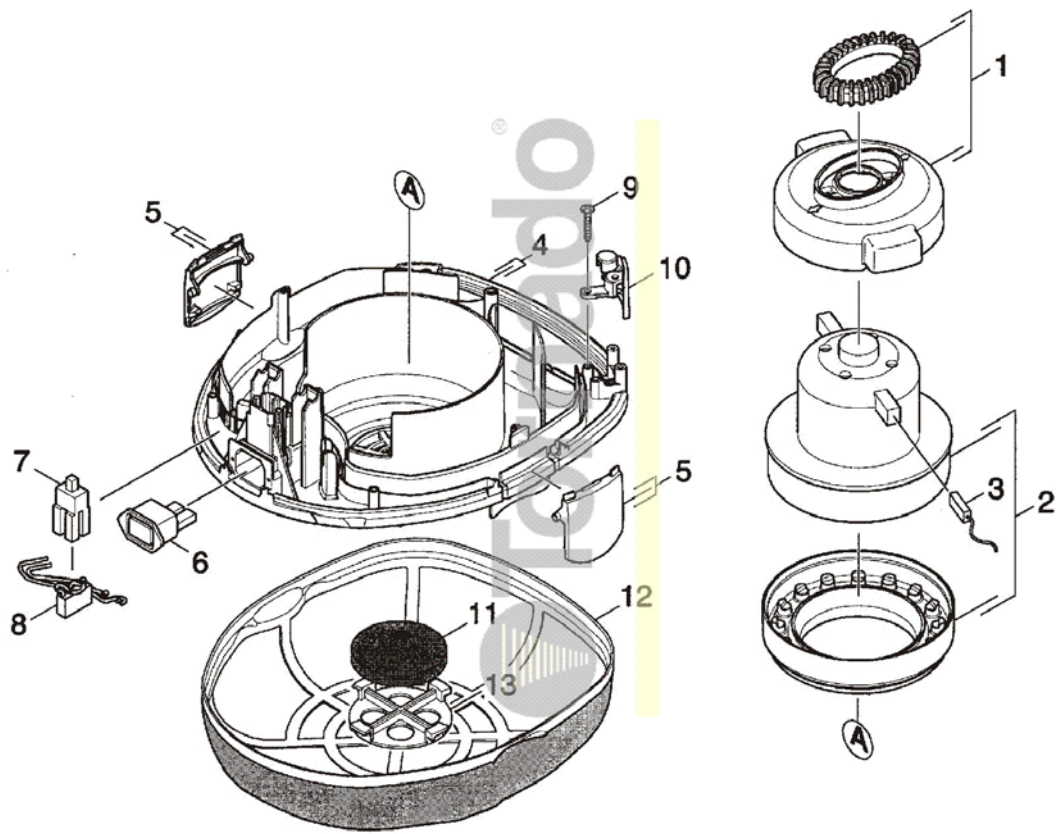

No.	Number	Qty	Description
1	K46050710	1	HOUSING
2	K46100660	1	VACUUM MOTOR
3	K66102580	1	CARBON BRUSH SET
4	K46050700	1	HOUSING
5	K50325680	2	LOCKING STRAP
6	K66462000	1	SOCKET
7	K66302140	1	SWITCH ON-OFF
8	K48393330	1	ELECTRIC
9	K73030840	2	SCREW 4 X 25
10	K50326720	1	PULL RELIEF
11	K64146110	1	MOTOR PROTECTION FILTER
12	K57316190	1	FILTERING BASKET
13	K50326740	1	MOLDED PART