

CONTROL HANDLE

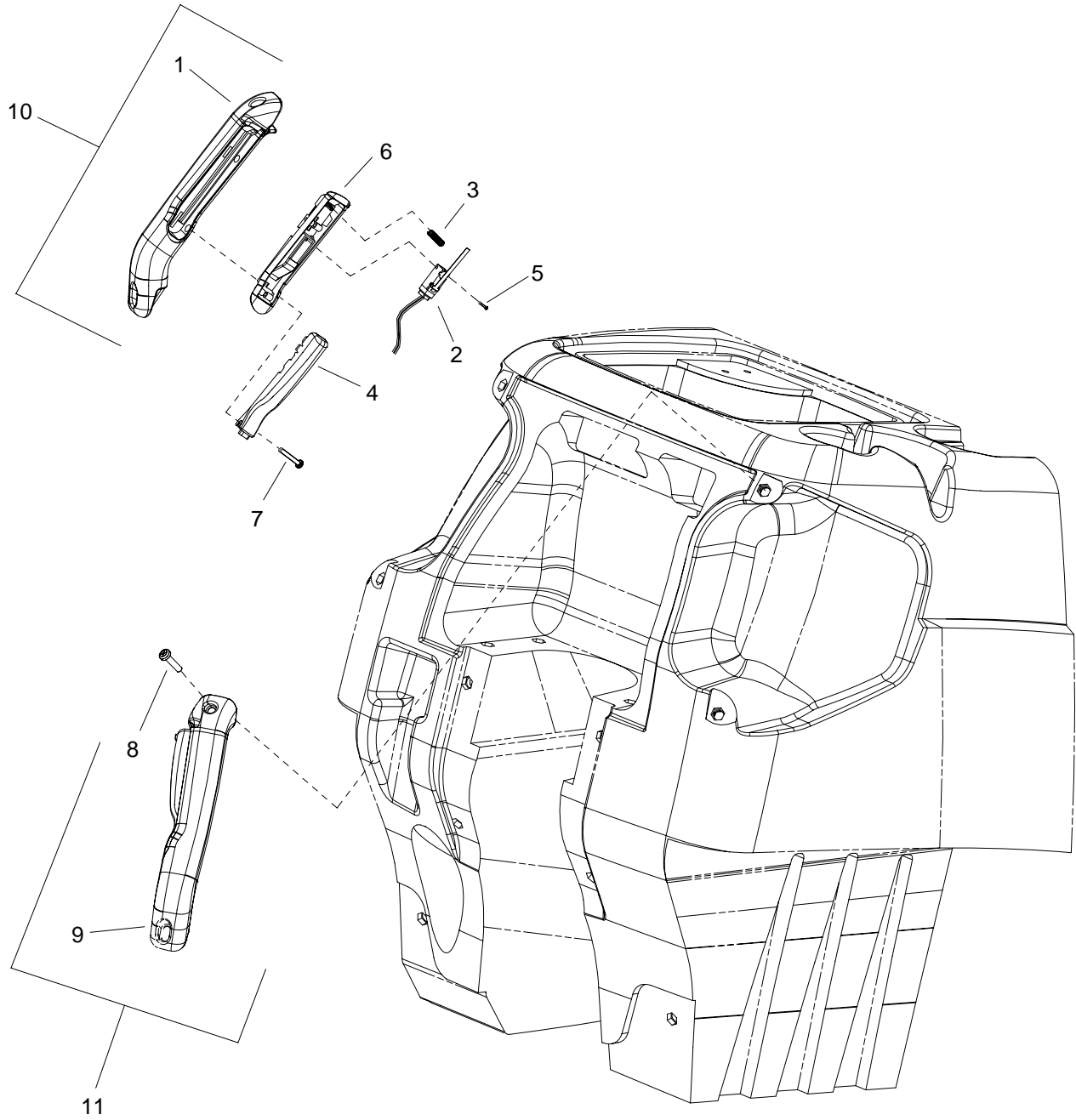

CONTROL HANDLE

REF	PART NO.	PRV NO.	QTY	DESCRIPTION	SERIAL NO. FROM	NOTES:
1	86238730	38307	1	HANDLE, LEFT		
2	86257230	730125	2	SWITCH, SPST MOM NO W/LEVER		
3	86254920	730153	2	SPRING, COMP .240D X 1.25 X .018		
4	86231480	140504	2	BUTTON, PROPEL		
5	86277070	70784	2	SCR, 4-40 X 5/8 PPHMS		
6	86240990	41431	2	HOUSING, BUTTON		
7	86277060	70783	4	SCR, 8-32 X 7/8 PHTC TYPE 23		
8	86277050	70782	4	SCR, 5/16-18 X 3/4 SHCS NP		
9	86238740	38308	1	HANDLE, RIGHT		
10	86004120	38312	-	PROPEL HANDLE ASM, LEFT		SRVC ONLY
11	86004130	38313	-	PROPEL HANDLE ASM, RIGHT		SRVC ONLY

COVER (FRONT) & TANK MOUNT

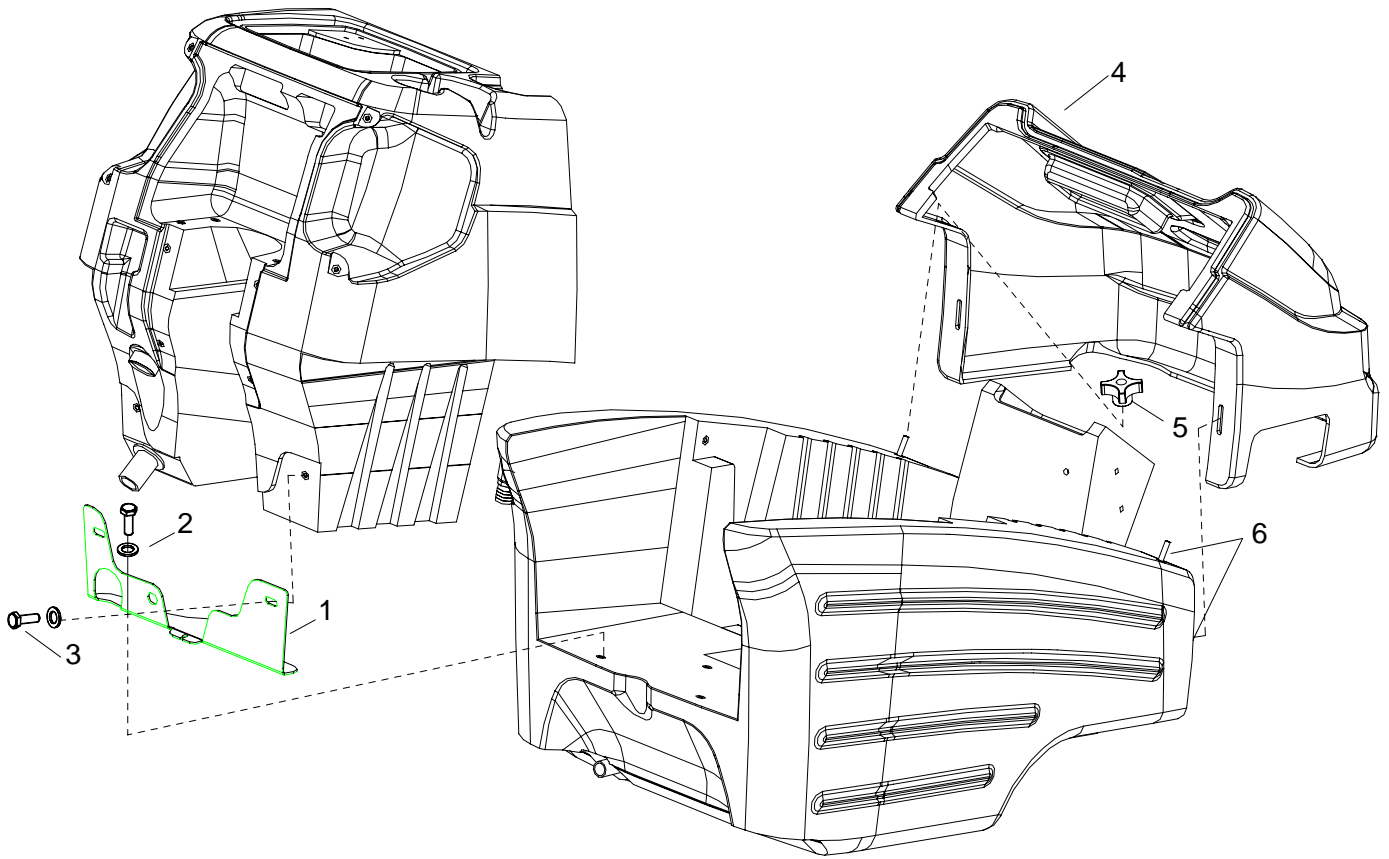

COVER (FRONT) & TANK MOUNT

REF	PART NO.	PRV NO.	QTY	DESCRIPTION	SERIAL NO. FROM	NOTES:
1	86069500	140468	1	BRACKET, REC TO SOL BACK		
2	86010670	87029	5	WASHER, 5/16 FLAT SS		
3	86276780	70728	5	SCR, 5/16-18 X 3/4 HHCS SS		
4	86062620	27976	1	COVER, FRONT SQZ PLAY 24V		
5	86004790	48012	2	KNOB, 5/16-18 4 PRONG		
6	86276380	70639	4	SCR, 5/16-18 X 1.25 SSSCU		

COVER (TOP) & TANK MOUNT

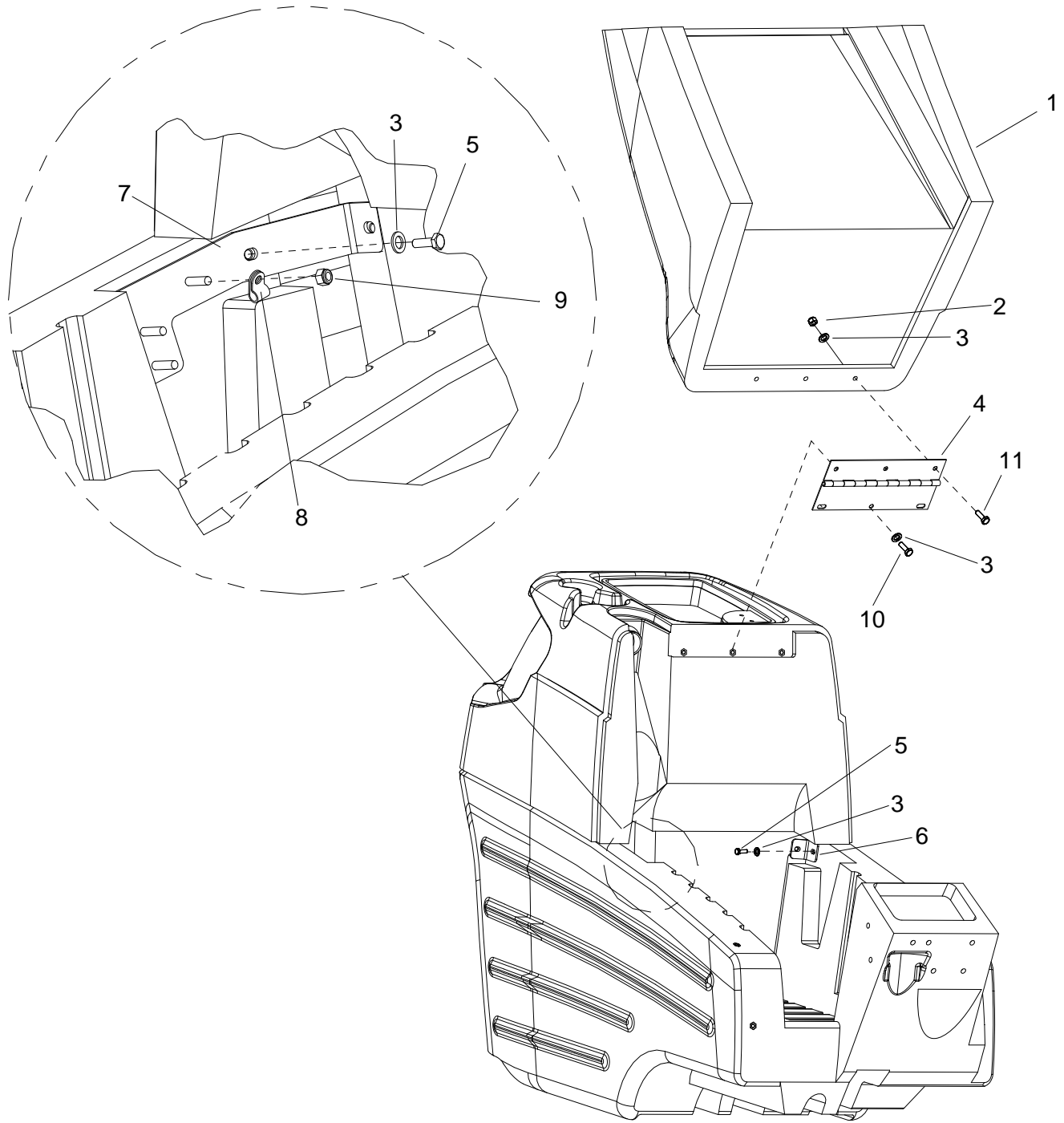

COVER (TOP) & TANK MOUNT

REF	PART NO.	PRV NO.	QTY	DESCRIPTION	SERIAL NO. FROM	NOTES:
1	86062540	27926	1	COVER, TOP 24V GRY		
2	86271840	57285	3	NUT, 5/16-18 HEX NYLOCK THIN SS		
3	86010670	87029	10	WASHER, 5/16 FLAT SS		
4	86239630	41429	1	HINGE, COVER TO TANK		
5	86276780	70728	4	SCR, 5/16-18 X 3/4 HHCS SS		
6	86073700	140484	1	BRACKET, TANK LEFT		
7	86069630	140485	1	BRACKET, TANK RIGHT		
8	86233390	80887	1	CLAMP, 7/8 DIA "P" CUSHIONED		
9	86271870	57290	1	NUT, 1/4-20 HEX NYLOCK THIN SS		
10	86276490	70670	3	SCR, 5/16-18 X 5/8 HHCS SS		
-	86247670	58004	1	NET, CARGO W/HOOKS		NOT SHOWN
11	86276780	70728	3	SCR, 5/16-18 X 3/4 HHCS SS		

DECAL

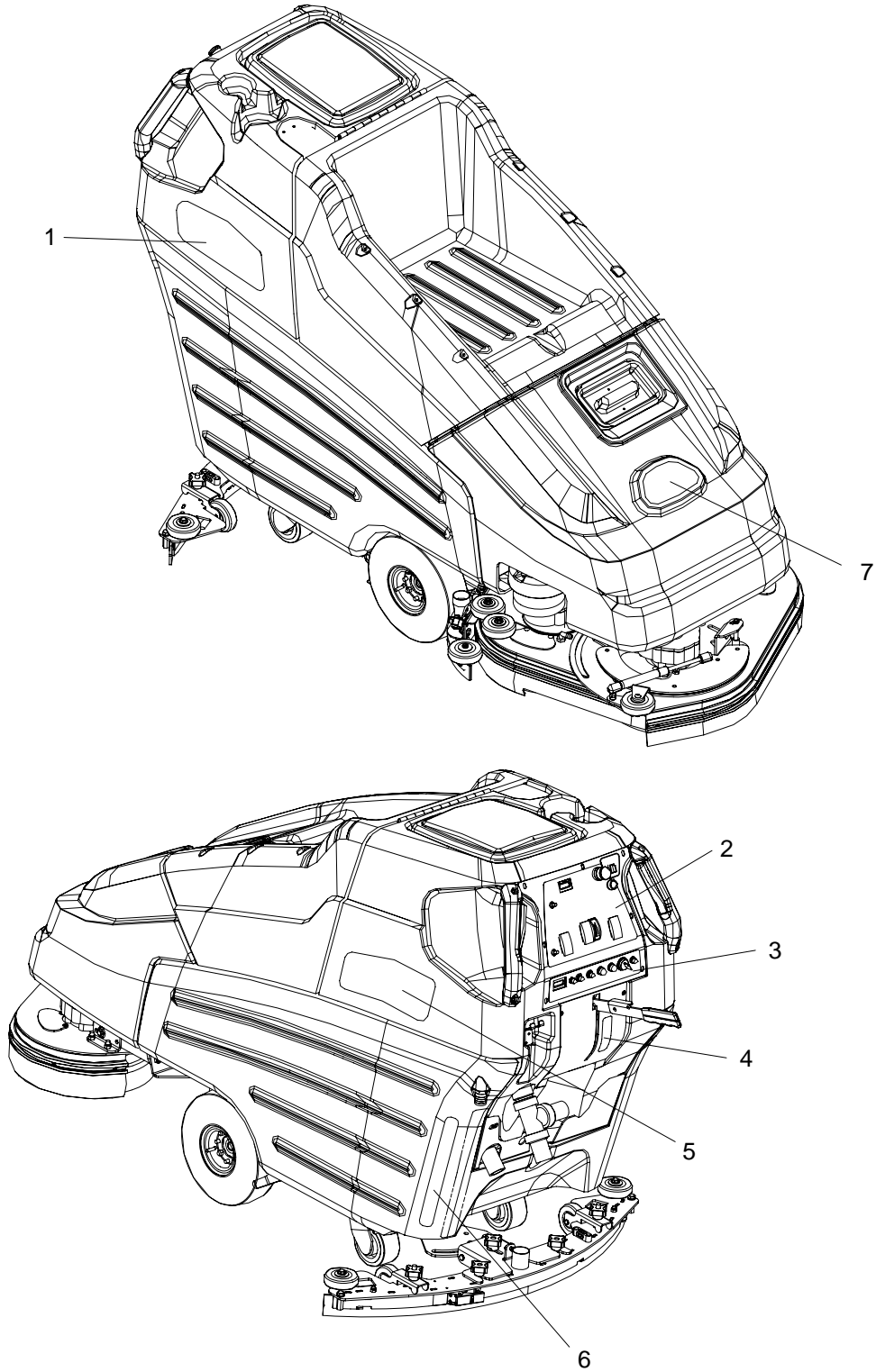

DECAL

REF	PART NO.	PRV NO.	QTY	DESCRIPTION	SERIAL NO. FROM	NOTES:
1	86243560	500573	1	LABEL, CUTTER RIGHT		
2	86243880	500690	1	LABEL, ELEC. PANEL SQZ PLAY		
3	86243530	500565	1	LABEL, ELEC. PANEL. LOWER 24V		
4	86243600	500578	1	LABEL, SQUEEGEE LEVER		
5	86243550	500572	1	LABEL, CUTTER LEFT		
6	86243180	500479	1	LABEL, SOLUTION FILL 24V		
7	86004970	50990	1	LABEL, WINDSOR LOGO DOMED		

ELECTRICAL PANEL

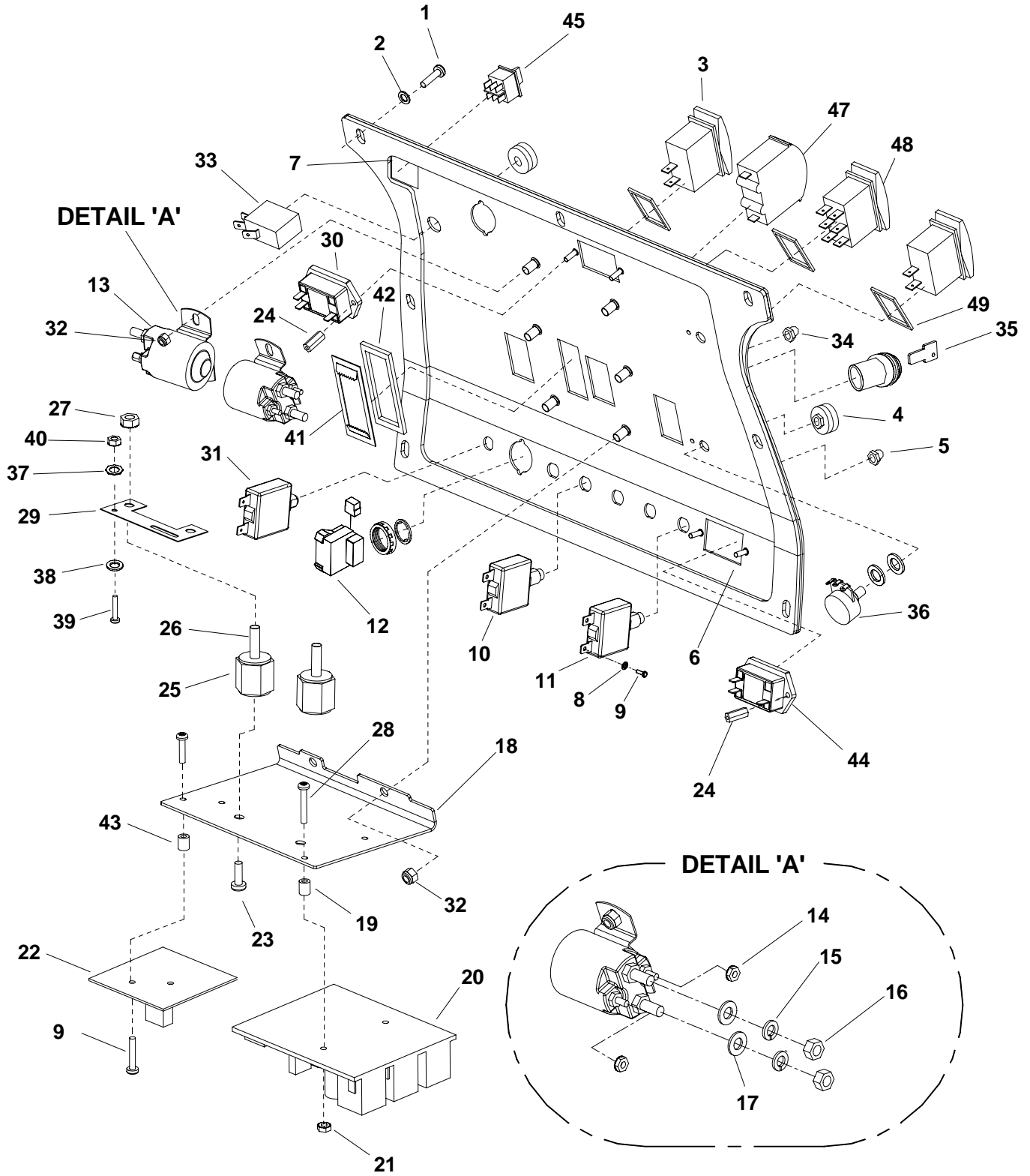

ELECTRICAL PANEL

REF	PART NO.	PRV NO.	QTY	DESCRIPTION	SERIAL NO. FROM	NOTES:
1	86276290	70626	7	SCR, #10 X 3/4 PPHST HI-LO BLK		
2	86294250	-	7	WASHER, .19 ID X .5 X .09TK BLK		
3	86007140	72130	2	SWITCH, SPST 2-POSITION ROCKER		
4	86242110	48088	2	KNOB, .90 OD X .25 COLLET		
5	86008900	80845	5	BOOT, SEAL-PUSH BUTTON 7/16-28		
6	86082580	62994	1	PLATE, ELEC. PANEL CUTTER 36"		
7	86237800	35261	1	GASKET, ELEC PLATE 24V		
8	86279300	87134	10	WASHER, #6 LOCK		
9	86273990	70067	14	SCR, 6-32 X 3/8 PPHMS		
10	86001910	14606	4	BREAKER, 30A 50VDC CIRCUIT		
11	86230070	140634	3	BREAKER, 20A THERMAL CIRCUIT		
12	86007170	72159	1	SWITCH KEY TWO POSITION		
13	86006420	67393	2	RELAY, 24VDC 100A		
14	86005700	57104	4	NUT10-32 W/STAR WASHER PLTD		
15	86279480	87166	4	WASHER, 5/16 EXT LOCK PLTD		
16	86271080	57117	4	NUT, 5/16-24 HEX PLTD		
17	86010760	87142	4	WASHER, .344 X .69 X .066 FLAT PLT		
18	86082820	66353	1	PLATE, ELECT. PANEL, BACK		
19	86254440	73734	2	SPACER, .166 ID X .313 OD X .375 L AL		
20	86002950	27695	1	CONTROLLER, 24VDC PROPEL MOTOR		
21	86270850	57026	2	NUT, 8-32 HEX NYLOCK		
22	86003250	27944	1	CIRCUIT BOARD, SOL FLOAT WIRED		
23	86276880	70751	2	SCR, 1/4-20 X 3/8 HHCS SS		
24	86255900	73538	4	STANDOFF, 6-32 x 1.0 HEX NYL		
25	86255910	73659	2	STANDOFF, 1/4-20 X 1.0 HEX INS		
26	86006850	70393	2	SET SCR, 1/4-20 X 1.25 L		
27	86005710	57105	2	NUT, 1/4-20 HEX W/STAR WASHER		
28	86273910	70045	2	SCR, 8-32 X 1 PPHMS		
29	86253630	73987	1	SHUNT, DC AMM. 25 AMP, 50MV		
30	86005520	54145	1	METER, 24V BATTERY CHARGE LEVEL		
31	86002000	14717	1	BREAKER, 3 AMP		
32	86271870	57290	6	NUT, 1/4-20 HEX NYLOCK THIN SS		
33	86257030	72168	1	SWITCH, MOMENTARY, DPST		
34	86002010	14942	1	BOOT, 3/8 CIRCUIT BREAKER		
35	86004860	48073	1	KEY SWITCH		SRVC ONLY
36	86279020	66335	1	POTENTIOMETER, 50K OHMS		SRVC ONLY
37	86279020	87026	2	WASHER, #6 LOCK EXT STAR SS		
38	86279600	87187	2	WASHER, #6 FLAT BRASS		
39	86276250	70615	2	SCR, 6-32 X 3/8 SRHMS BR		
40	86271790	57256	2	NUT, 6-32 HEX BRASS		
41	86249290	62283	1	PLATE, METER RETAINING		
42	86237830	35264	1	GASKET, AMP METER		
43	86255890	730164	2	STANDOFF, 6-32 X 1.0 HEX NYL		
44	86005530	54154	1	METER, 12-48 VDC LED HOUR		
45	86257080	72178	1	SWITCH, DPDT ROCKER W/PADDLE		
45	86267340	880269	2	WIRE, 22" RED/18 76040 X 76075		NOT SHOWN
46	86267360	880271	1	WIRE, 14" BLK/18 76011 X 76040		NOT SHOWN
47	86246940	54156	1	METER, 0-50AMP DC		
48	86007210	72165	1	SWITCH, DPDT 3-POSITION ROCKER		
49	86238030	36235	3	GASKET, SWITCH CARLING		

LIFT HANDLE

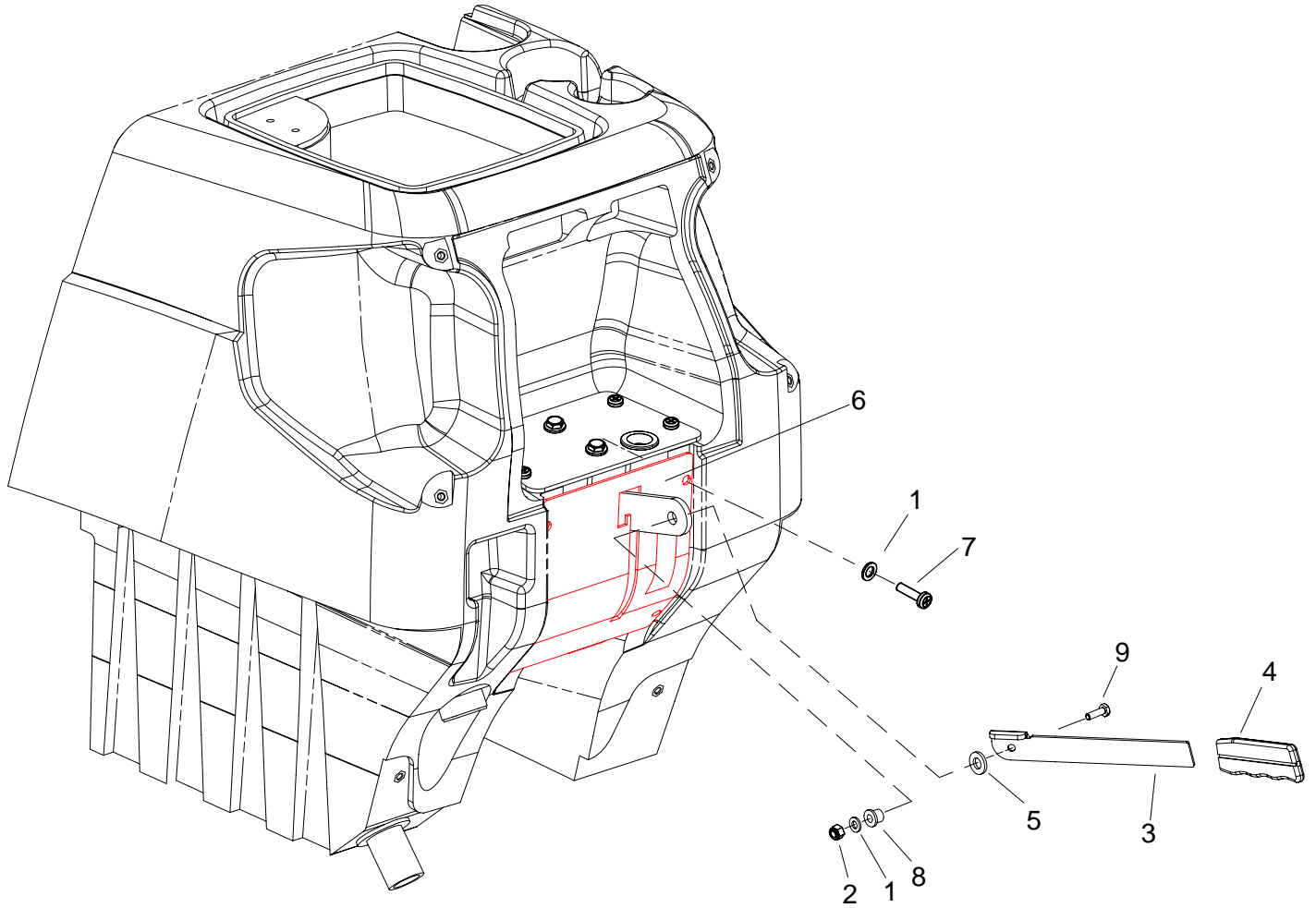

LIFT HANDLE

REF	PART NO.	PRV NO.	QTY	DESCRIPTION	SERIAL NO. FROM	NOTES:
1	86010670	87029	5	WASHER, 5/16 FLAT SS		
2	86271840	57285	1	NUT, 5/16-18 HEX NYLOCK THIN SS		
3	86066860	140537	1	BAR, SQG LIFT SWING		
4	86238360	36215	1	GRIP, 3/16 X 1.0 ORANGE		
5	86259400	87205	1	WASHER, THRUST .51ID X 1OD BRO		
6	86082390	62961	1	PLATE, LEVER NOTCH 24V DLX		
7	86276780	70728	4	SCR, 5/16-18 X 3/4 HHCS SS		
8	86228840	09124	1	BEARING, FLANGED .314 ID X .502 OD		
9	86006930	70514	1	SCR, 5/16-18 X 1.00 BSHCS SS		

LIFT HANDLE LINKAGE

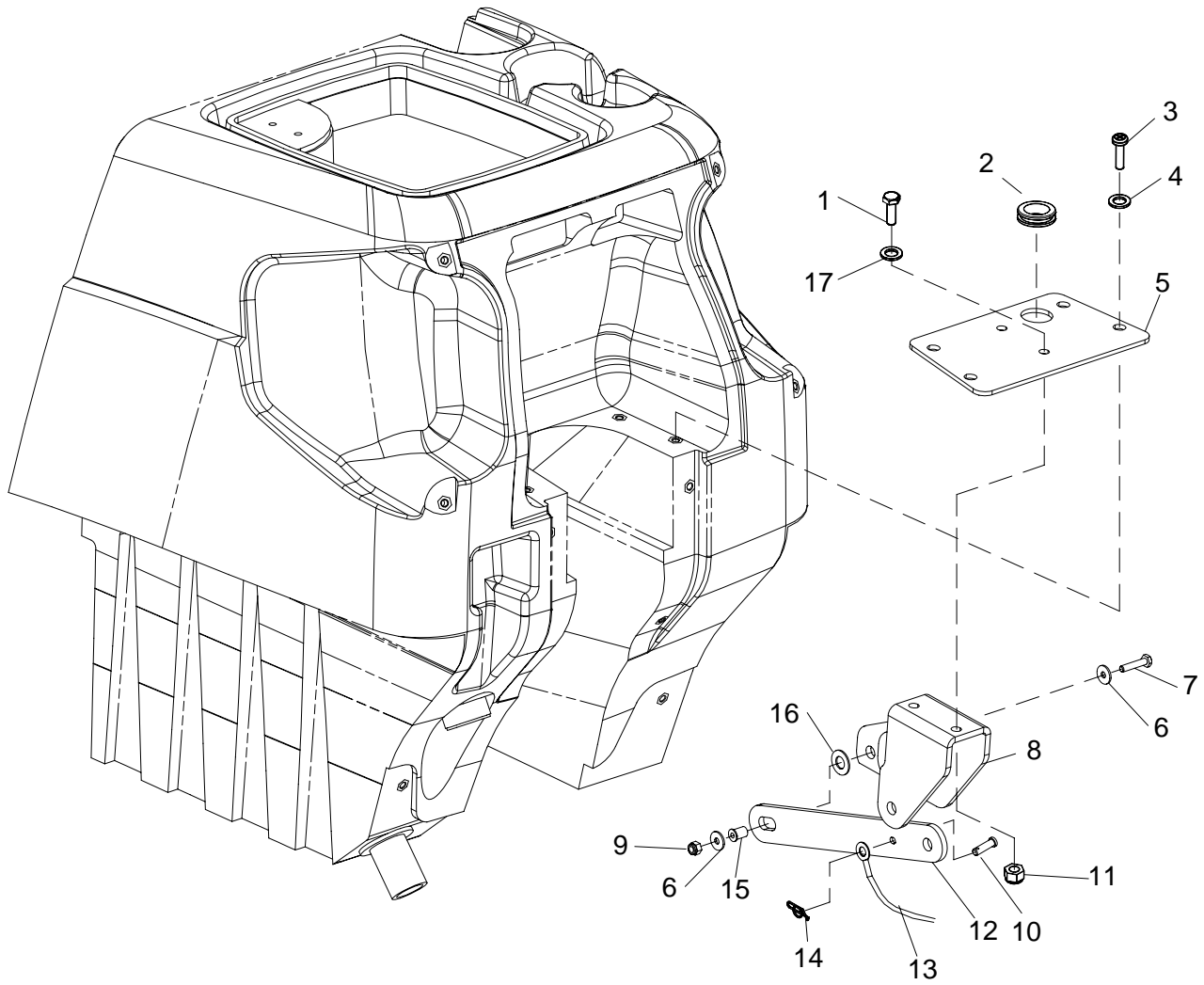

LIFT HANDLE LINKAGE

REF	PART NO.	PRV NO.	QTY	DESCRIPTION	SERIAL NO. FROM	NOTES:
1	86276920	70755	2	SCR, 3/8-16 X 1 HHCS SS NP		
2	86238430	36191	1	GROMMET, 1.00ID 3/16 GRIP		
3	86276780	70728	4	SCR, 5/16-18 X 3/4 HHCS SS		
4	86010670	87029	4	WASHER, 5/16 FLAT SS		
5	86082270	62946	1	PLATE, PIVOT		
6	86010630	87013	2	WASHER, 1/4ID X 5/8OD SS		
7	86273820	70019	1	SCR, 1/4-20 X 1.25 HHCS SS		
8	86069610	140482	1	BRACKET, SCRUB DECK PIVOT 24V		
9	86271870	57290	1	NUT, 1/4-20 HEX NYLOCK THIN SS		
10	86009560	82053	1	PIN, CLEVIS 1/4" X 5/8" PLTD		
11	86005630	57022	2	NUT, 3/8-16 HEX NYLOCK THIN SS		
12	86077480	51365	1	LINK, SQG LIFT FIXED		
13	86003240	27942	1	CABLE, .125 X 26.5 0707 SS LB E-E		
14	86008650	80604	1	COTTER, 1/4" RING		
15	86228900	09138	1	BEARING, FLANGED .252ID X .503OD		
16	86259400	87205	1	WASHER, THRUST .51ID X 1OD BRO		
17	86278910	87003	2	WASHER, 3/8 ID X 7/8 OD SS		

RECOVERY TANK

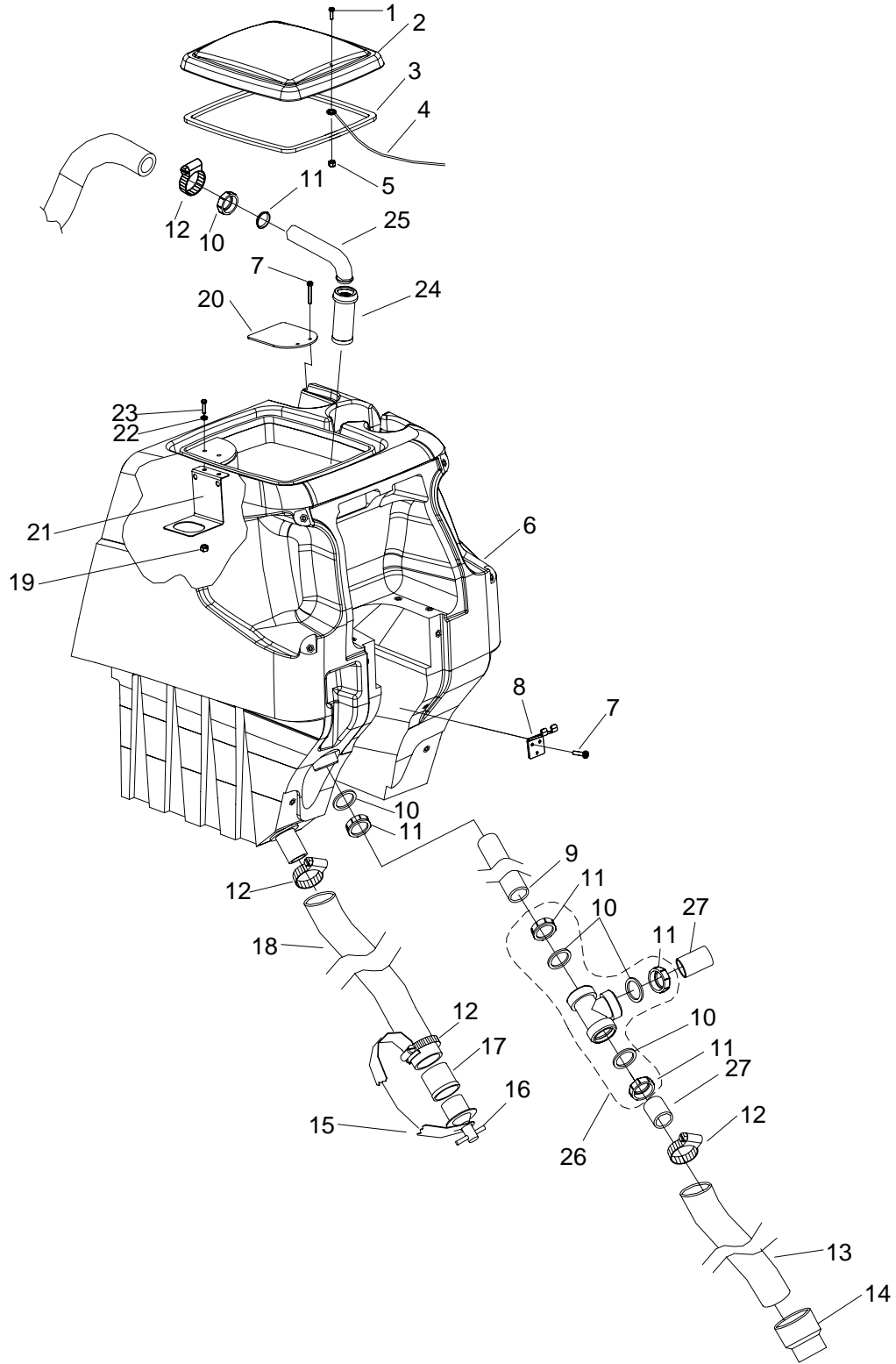

RECOVERY TANK

REF	PART NO.	PRV NO.	QTY	DESCRIPTION	SERIAL NO. FROM	NOTES:
1	86273950	70134	1	SCR, 6-32 X 5/8 PPHMS SS		
2	86003340	28062	1	DOME, 13 X 11		
3	86003990	35250	1	GASKET, DOME		
4	86246080	51368	1	LANYARD, 18.0 W/ LOOP & EYE		
5	86014810	-	1	NUT, 6-32 ACORN SS		
6	86032540	75371	1	TANK, RECOVERY 24V		
7	86276290	70626	5	SCR, #10 X 3/4 PPHST HI-LO BLK		
8	86001190	140133	1	BRACKET, RECOVERY HOSE MTG		
9	86089630	78490	1	TUBE, 1.5 PVC X 24.0		
10	86237650	35219	5	GASKET, 1-1/2 COMPRESSION		
11	86005660	57033	5	NUT, 1.5 SLIP JOINT		
12	86002400	20064	4	CLAMP, 2.0" WORM GEAR X .312W		
13	86004180	39315	1	HOSE, 1.5 BLK VAC X 28"		
14	86002840	27282	1	CUFF, 1.5 SLIP X 1.5 HOSE		
15	86008400	78499	1	TETHER, DRAIN PLUG		
16	86006240	66227	1	PLUG, DRAIN HOSE		
17	86004450	40019	1	HOSEBARB, 1.5 DOUBLE MCHD		
18	86004260	39472	1	HOSE, 1.5 X 24.0 DRAIN		
19	86271870	57290	2	NUT, 1/4-20 HEX NYLOCK THIN SS		
20	86075540	27941	1	COVER, VACUUM HOSE		
21	86069780	140511	1	BRACKET, VAC INTAKE		
22	86010630	87013	2	WASHER, 1/4ID X 5/8OD SS		
23	86273810	70018	2	SCR, 1/4-20 X 1 HHCS SS		
24	86236410	34394	1	FLOAT, VAC SHUT OFF		
25	86257860	78390	1	TUBE, 1.5 WASTE		
26	86257350	78537	1	TEE, COMPRESSION 1.5 TUBULAR		
27	86089640	78494	2	TUBE, 1.5DX.070W2.80L PVC		

SCRUB BRUSH/PAD DRIVER

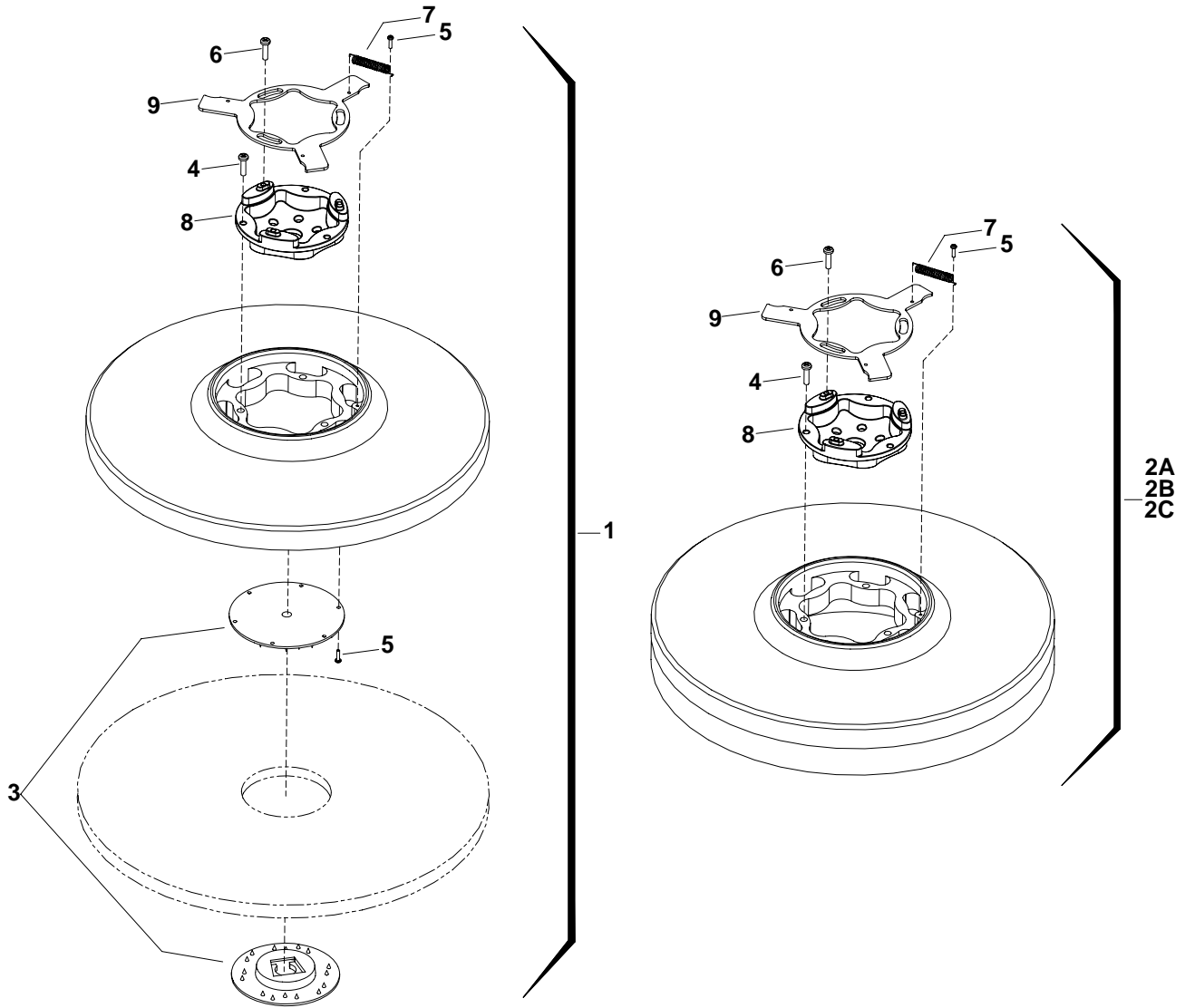

SCRUB BRUSH/PAD DRIVER

REF	PART NO.	PRV NO.	QTY	DESCRIPTION	SERIAL NO. FROM	NOTES:
1	86000170	02400	2	PAD DRIVER, 12" SD		
2A	86000180	02401	2	BRUSH, 12" POLYPROPYLENE SD		
2B	86000190	02402	2	BRUSH, 12" NYLON SD		
2C	86000200	02404	2	BRUSH, 12" NYLON POLISH SD		
3	86005070	51284	1	LOCK, PAD CENTER SNAP, TWO STEP		
4	86276590	70695	3	SCR, 12-24 X 1.0 PPHMS SS		
5	86276580	70694	4	SCR, 8-32 X 3/4 PTHMS		
6	86276600	70696	3	SCR, 10-32 X 3/4 PTHMS		
7	86007910	73817	1	SPRING, EX .31 D X 2.0 L X .03 W SS		
8	86007280	730011	1	SOCKET, DRIVE BRUSH		
9	86005940	62852	1	PLATE, BRUSH RELEASE		

SCRUB DECK MOTORS

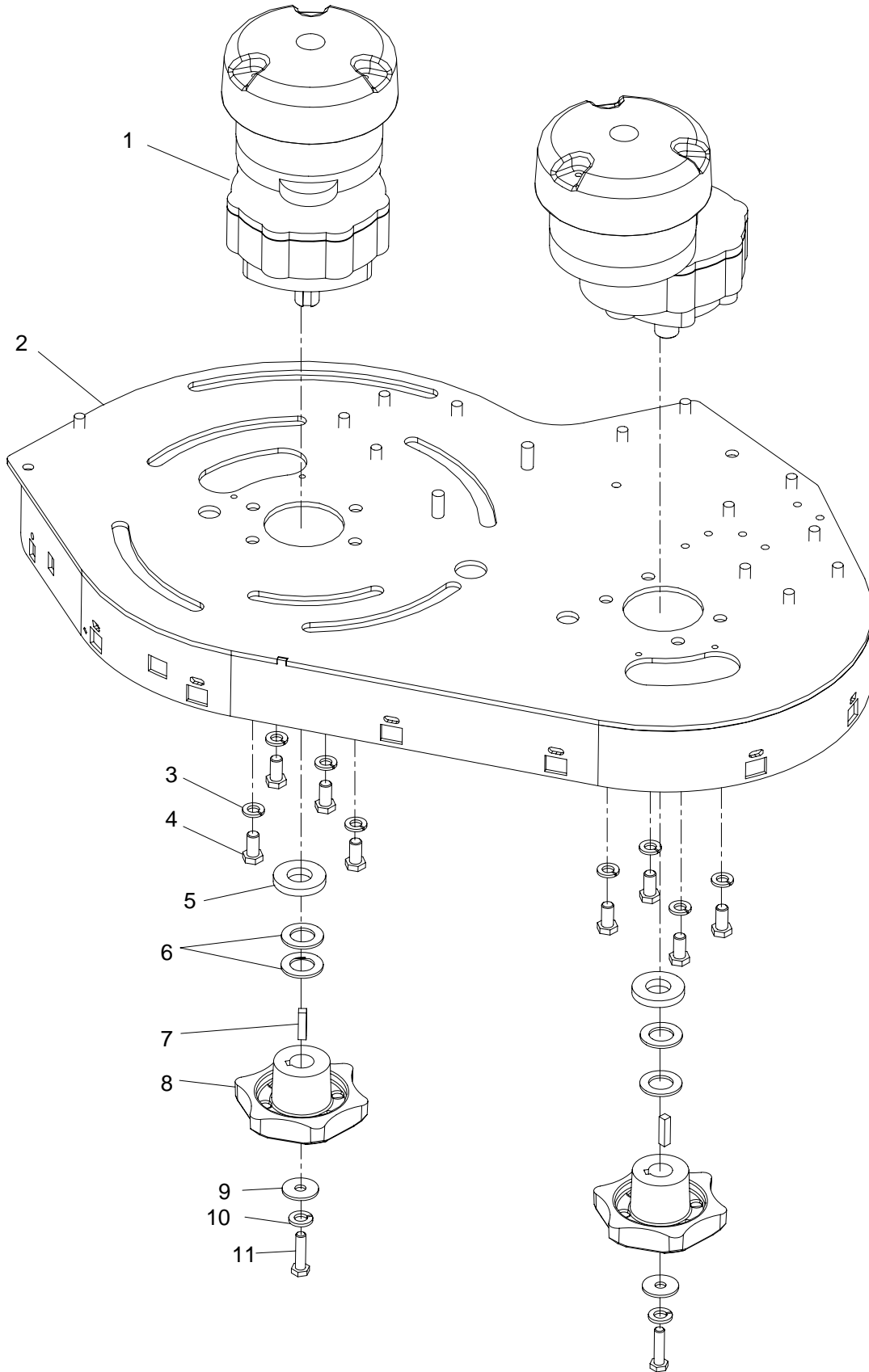

SCRUB DECK MOTORS

REF	PART NO.	PRV NO.	QTY	DESCRIPTION	SERIAL NO. FROM	NOTES:
1	86005390	53644	2	MOTOR ASM, 24VDC 180RPM GEAR		
1A	86216170	140627	REF	BRUSH SET		SRVC ONLY
2	86092450	34400	1	FRAME, SQZ PLAY ASM L		
3	86010790	87163	8	WASHER, 3/8 SPLIT LOCK PLTD		
4	86276970	70774	8	SCR, 3/8-16 X 3/4 HHCS SS		
5	86279640	87213	2	WASHER, .78ID X 1.63OD X .25T PLTD		
6	86279530	87173	4	WASHER, .77 X 1.31 FLAT SS		
7	86004810	48040	2	KEY, 1/4 SQ. X 1.00		SUPP W/ MTR
8	86003420	29220	2	DRIVER, BRUSH SD		
9	86279630	87212	2	WASHER, .344ID X 1.13OD X .09T PLTD		
10	86279130	87083	2	WASHER, 5/16 SPLIT LOCK PLTD		
11	86007020	70673	2	SCR, 5/16-18 X 1.25 HHCS SS		

SCRUBDECK RIGHT FRAME

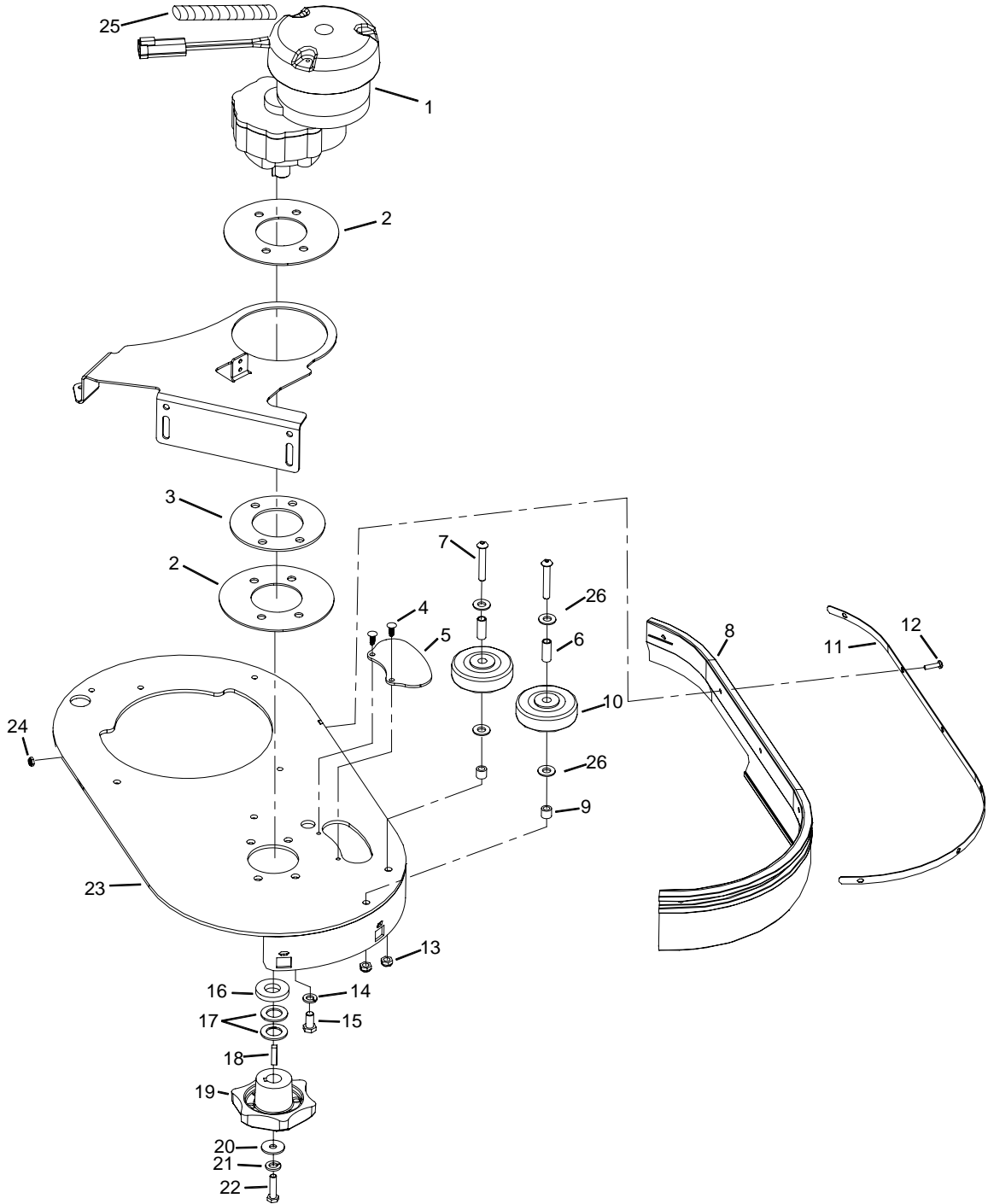

SCRUBDECK RIGHT FRAME

REF	PART NO.	PRV NO.	QTY	DESCRIPTION	SERIAL NO. FROM	NOTES:
1	86005390	53644	1	MOTOR ASM, 24VDC 180RPM GEAR		
2	86065050	730180	2	SPACER, MOTOR .105 THK		
3	86065040	730179	1	SPACER, TOP SQG LINKAGE		
4	86233560	80805	2	CLIP, TREE .19 HOLE FLAT HEAD		
5	86234820	27977	1	COVER, BRUSH RELEASE 4.25 X 2.47		
6	86001350	140390	2	BUSHING, SPANNER .435 X 1.10		
7	86277150	70797	2	SCR, 5/16-18 X 2.0 BSHCS SS		
8	86253980	730201	1	SKIRT, 3.5 X 34 EXT		
9	86007650	730329	2	SPACER, .438 D X .317 ID X .25L		
10	86011020	89202	2	WHEEL, 3" DIA CUSHION RUBBER		
11	86087990	730185	1	STRAP, SKIRT LEFT		
12	86274070	70086	6	SCR, 10-24 X 1/2 PPHMS SS		
13	86271840	57285	2	NUT, 5/16-18 HEX NYLOCK THIN SS		
14	86010790	87163	4	WASHER, 3/8 SPLIT LOCK PLTD		
15	86276920	70755	4	SCR, 3/8-16 X 1 HHCS SS NP		
16	86279640	87213	1	WASHER, .78ID X 1.63OD X .25T PLTD		
17	86279530	87173	2	WASHER, .77 X 1.31 FLAT SS		
18	86004810	48040	1	KEY, 1/4 SQ. X 1.00		SUPP W/ MTR
19	86003420	29220	1	DRIVER, BRUSH SD		
20	86279630	87212	1	WASHER, .344ID X 1.13OD X .09T PLTD		
21	86279130	87083	1	WASHER, 5/16 SPLIT LOCK PLTD		
22	86007020	70673	1	SCR, 5/16-18 X 1.25 HHCS SS		
23	86092440	34399	1	FRAME, SQZ PLAY ASM RIGHT		
24	86271900	57294	6	NUT, 10-24 HEX NYLOCK THIN SS		
25	86279900	29199	1	DUCT, 10.5" SPLIT FLEX		
26	86010670	87029	4	WASHER, 5/16 FLAT SS		

SCRUBDECK LEFT FRAME

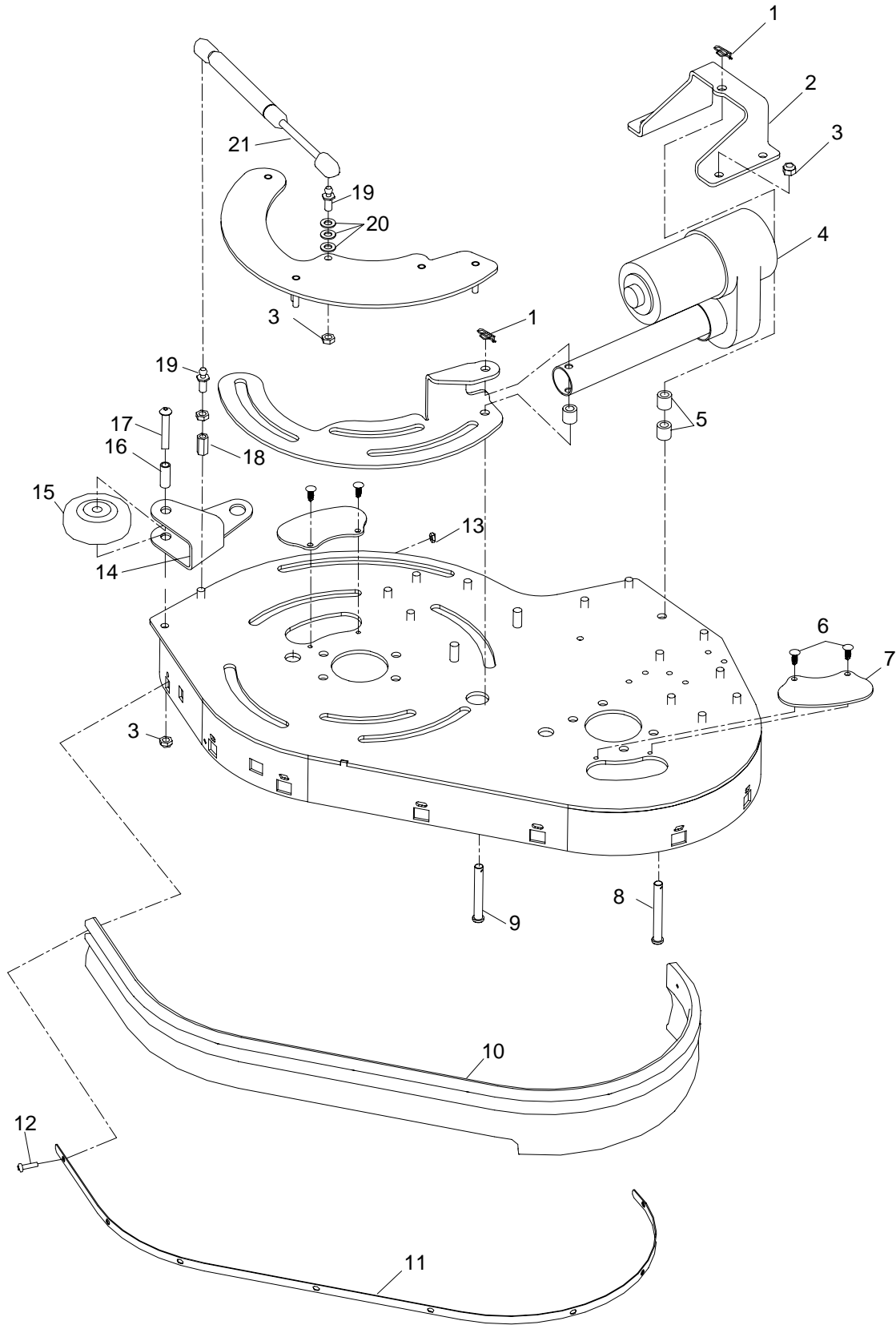

SCRUBDECK LEFT FRAME

REF	PART NO.	PRV NO.	QTY	DESCRIPTION	SERIAL NO. FROM	NOTES:
1	86008670	80606	2	COTTER, 3/8" RING		
2	86070290	140609	1	BRKT, ACTUATOR MOUNT		
3	86271840	57285	6	NUT, 5/16-18 HEX NYLOCK THIN SS		
4	86014670	-	1	ACTUATOR, 24V 4.9 STROKE DBLS		
5	86231280	14400	3	BUSHING, .377ID X .627 OD X .63		
6	86233560	80805	4	CLIP, TREE .19 HOLE FLAT HEAD		
7	86234820	27977	2	COVER, BRUSH RELEASE 4.25 X 2.47		
8	86272530	66393	1	PIN, CLEVIS 3/8 X 3.00		
9	86272520	66392	1	PIN, CLEVIS 3/8 X 2.75		
10	86253970	730200	1	SKIRT, 3.5 X 40 EXT		
11	86087980	730184	1	STRAP, SKIRT RIGHT		
12	86274070	70086	8	SCR, 10-24 X 1/2 PPHMS SS		
13	86271900	57294	8	NUT, 10-24 HEX NYLOCK THIN SS		
14	86070390	140630	1	BRKT, BUMPER WHEEL MOUNT		
15	86011020	89202	1	WHEEL, 3" DIA CUSHION RUBBER		
16	86001350	140390	1	BUSHING, SPANNER .435 X 1.10		
17	86277150	70797	1	SCR, 5/16-18 X 2 BSHCS		
18	86271950	57300	1	NUT, 5/16-18 HEX COUPLING SS		
19	86256500	80649	2	STUD, BALL GAS SPRING		
20	86010670	87029	3	WASHER, 5/16 FLAT SS		
21	86254930	730181	1	SPRING, GAS 9.6 300 NEWTONS		

SCRUBDECK

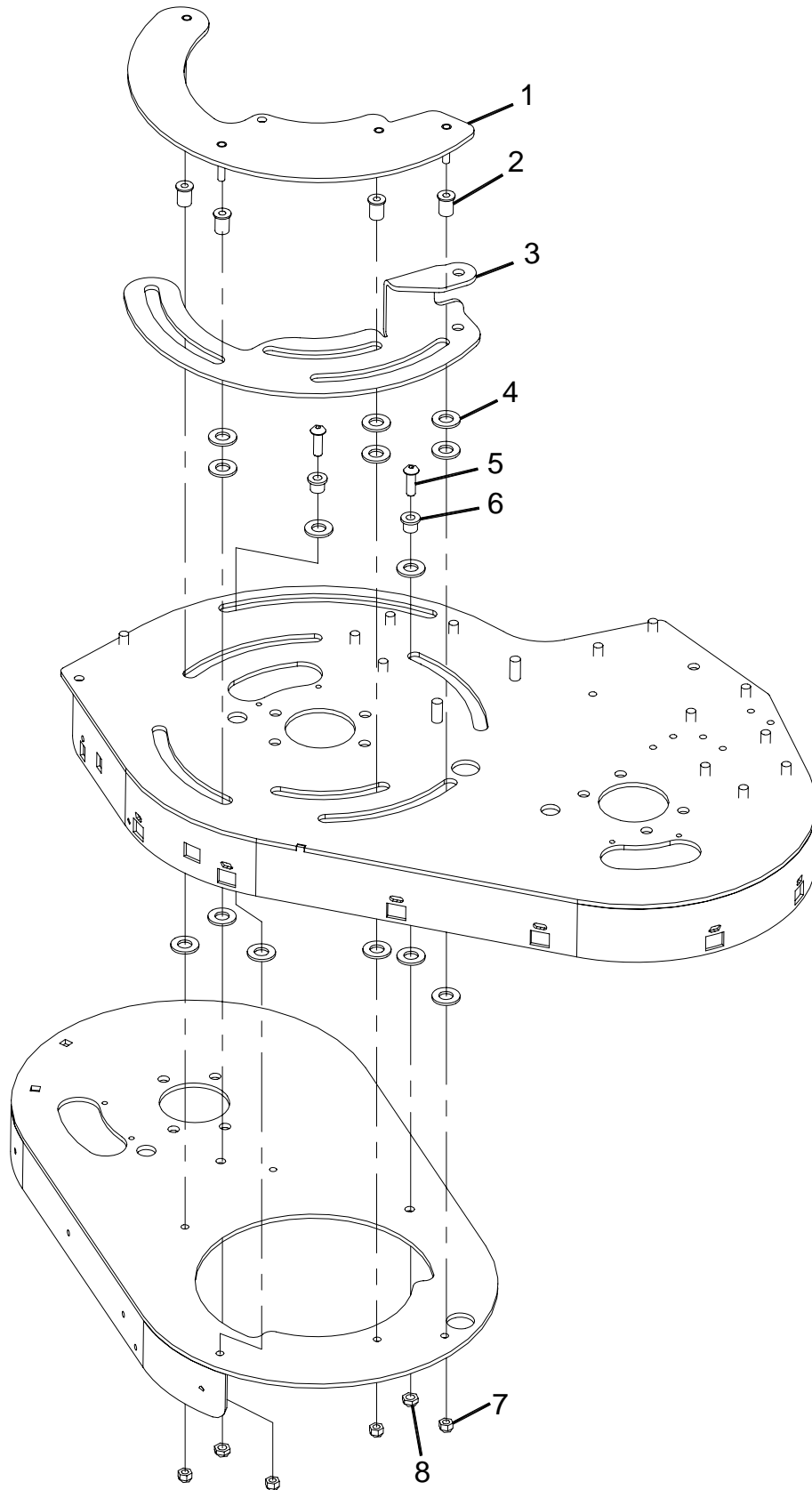

SCRUBDECK

REF	PART NO.	PRV NO.	QTY	DESCRIPTION	SERIAL NO. FROM	NOTES:
1	86070360	140620	1	BRKT, SQZ PLAY SLIDER		
2	86228900	09138	4	BEARING, FLANGED .252 ID X .503 OD		
3	86070260	140606	1	BRKT, SIDE ACTUATOR		
4	86259420	87232	14	WASHER, THRUST .51 ID X 1 OD BRO		
5	86006930	70514	2	SCR, 5/16-18 X 1.00 BSHCS SS		
6	86228840	09124	2	BEARING, FLANGED .314 ID X .502 OD		
7	86271870	57290	4	NUT, 1/4-20 HEX NYLOCK THIN SS		
8	86271840	57285	2	NUT, 5/16-18 HEX NYLOCK THIN SS		

SCRUBDECK LINKAGE

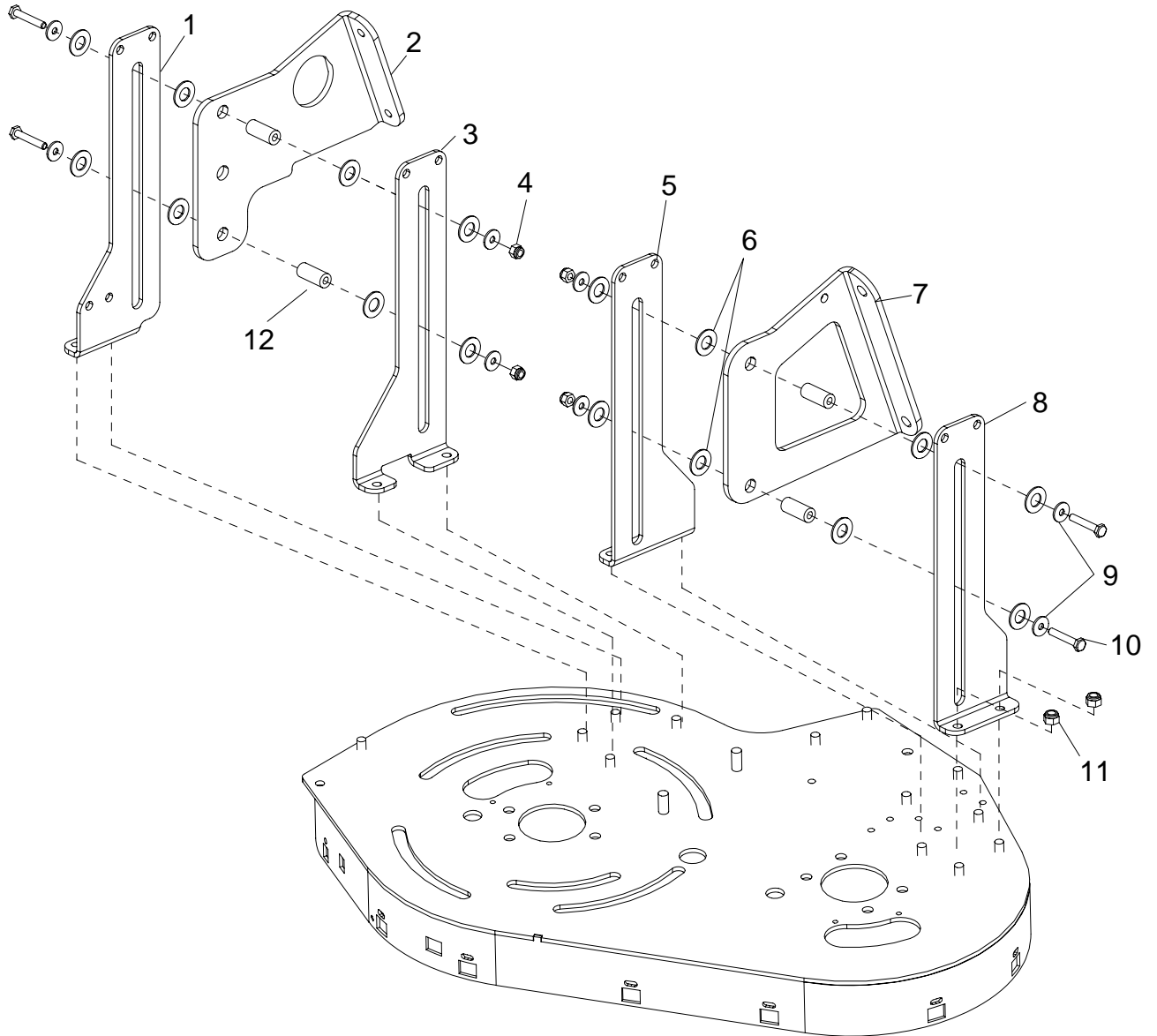

SCRUBDECK LINKAGE

REF	PART NO.	PRV NO.	QTY	DESCRIPTION	SERIAL NO. FROM	NOTES:
1	86076170	36224	1	GUIDE, SQZ PLAY DECK RR		
2	86070280	140608	1	BRKT, DECK LINKAGE RIGHT		
3	86076160	36223	1	GUIDE, SQZ PLAY DECK RL		
4	86271870	57290	4	NUT, 1/4-20 HEX NYLOCK THIN SS		
5	86076150	36222	1	GUIDE, SQZ PLAY DECK LL		
6	86259410	87206	16	WASHER, THRUST .51 ID X 10 D X .063		
7	86070270	140607	1	BRKT, DECK LINKAGE LEFT		
8	86076140	36221	1	GUIDE, SQZ PLAY DECK LR		
9	86010630	87013	8	WASHER, 1/4 ID X 5/8OD SS		
10	86273740	70010	4	SCR, 1/4-20 X 1.5 HHCS SS		
11	86271840	57285	8	NUT, 5/16-18 HEX NYLOCK THIN SS		
12	86228920	09140	4	BEARING, .252 ID X .503 OD X 1.0		

SCRUBDECK LINKAGE

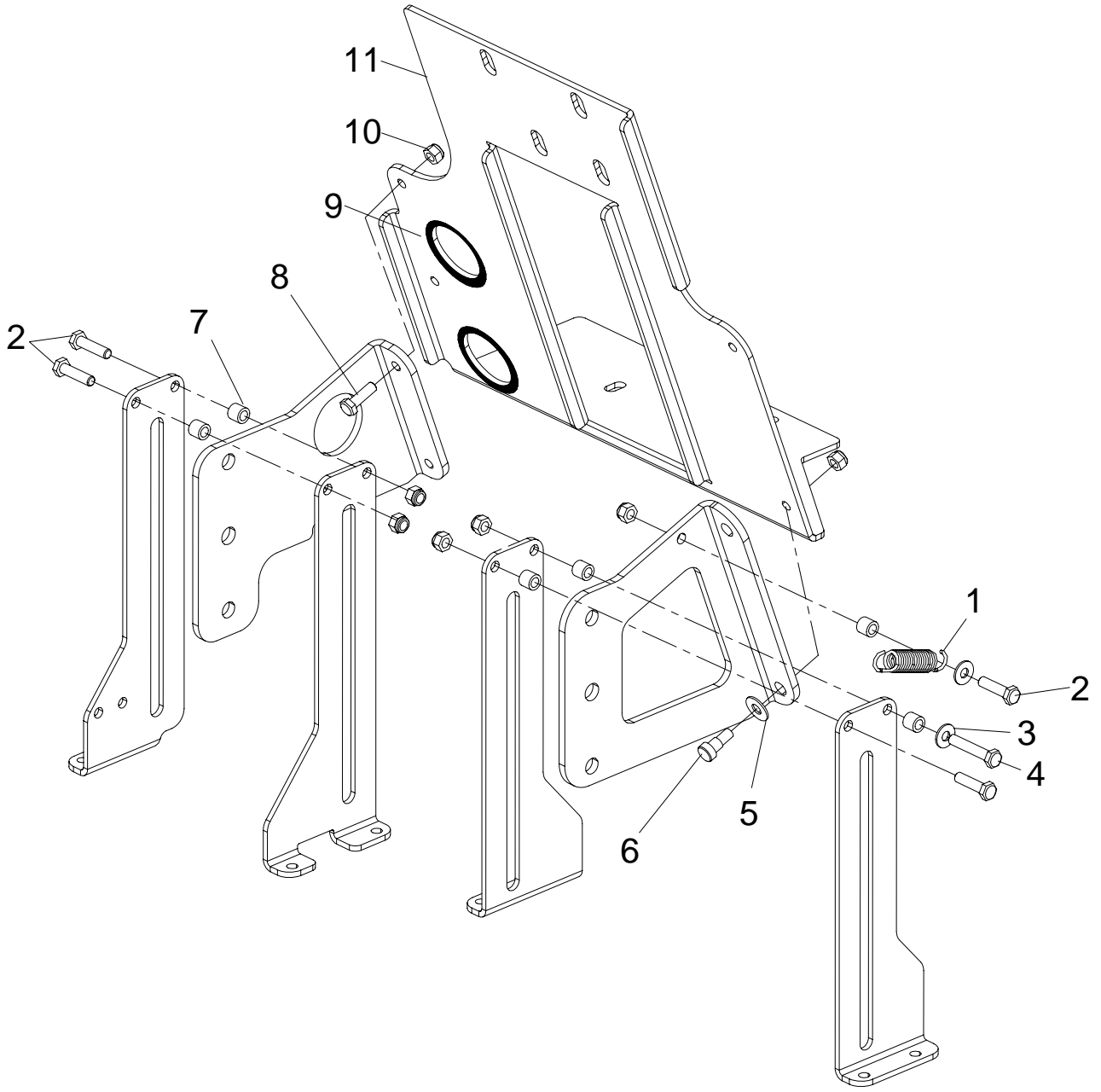

SCRUBDECK LINKAGE

REF	PART NO.	PRV NO.	QTY	DESCRIPTION	SERIAL NO. FROM	NOTES:
1	86226830	73268	1	SPRING, EXT .68 D X 3.00 L X .098 W		
2	86007020	70673	4	SCR, 5/16-18 X 1.25 HHCS SS		
3	86010670	87029	2	WASHER, 5/16 FLAT SS		
4	86276790	70732	1	SCR, 5/16-18 X 1.75 HHCS SS		
5	86278910	87003	2	WASHER, 3/8ID X 7/8OD SS		
6	86278330	70641	2	SHOULDER BOLT, 3/8 OD X 3/8 L SS		
7	86224290	730008	6	SPACER, .317 ID X .5 OD X .44 LG		
8	86006560	70083	2	SCR, 5/16-18 X 1 HHCS SS NP		
9	86238510	82994	2	GROMMET, 1.75 ID X 2.50 OD X.25		
10	86271840	57285	9	NUT, 5/16-18 HEX NYLOCK THIN SS		
11	86075860	34401	1	FRAME, MAINT TOWER		

SCRUB DECK LIFT

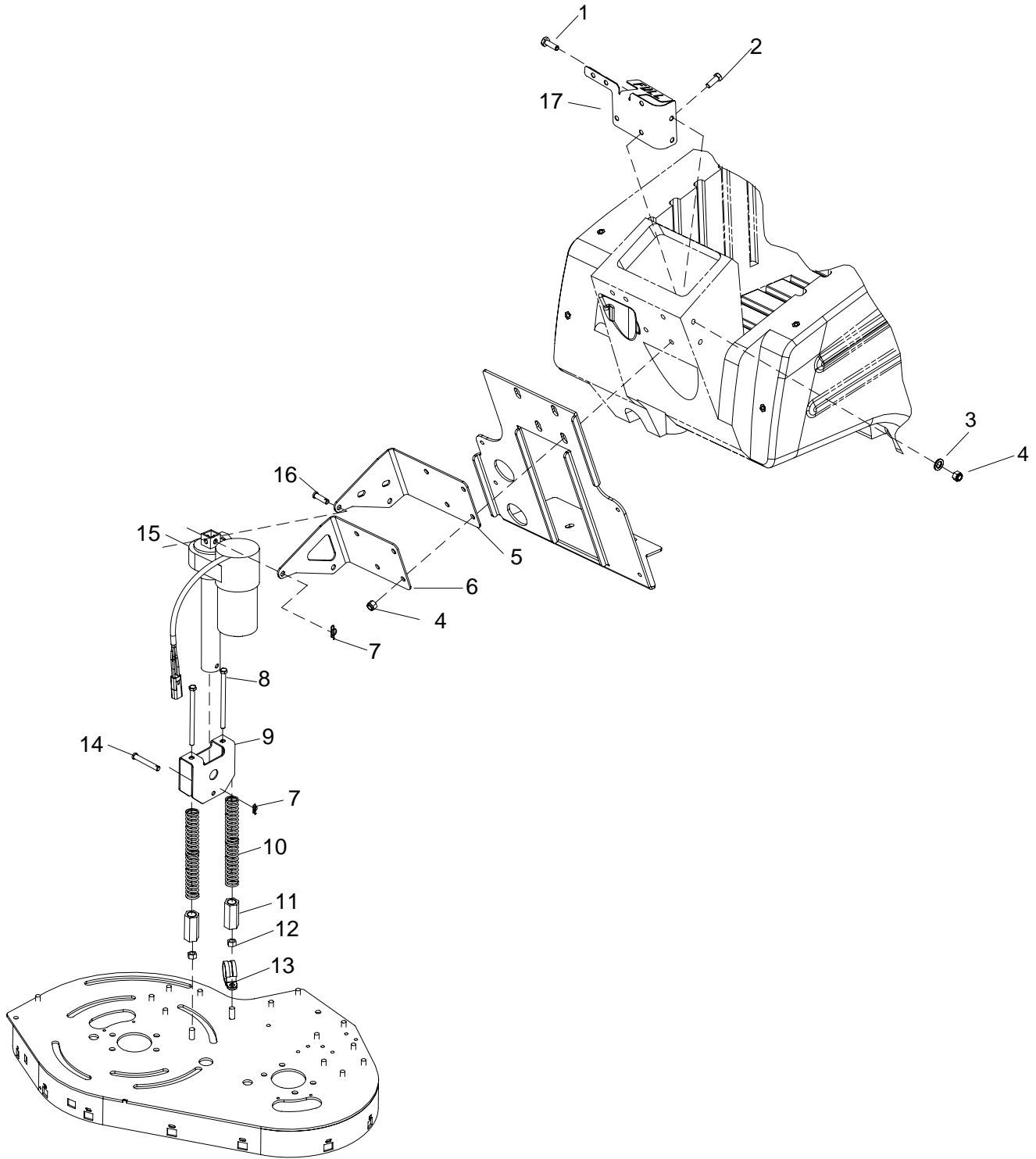

SCRUB DECK LIFT

REF	PART NO.	PRV NO.	QTY	DESCRIPTION	SERIAL NO. FROM	NOTES:
1	86276920	70755	2	SCR, 3/8-16 X 1 HHCS SS NP		
2	86276430	70647	4	SCR, 3/8-16 X 1.75 HHCS SS		
3	86279590	87185	2	WASHER, 3/8 SEALING X 3/4 OD		WAS 87003
4	86005630	57022	6	NUT, 3/8-16 HEX NYLOCK THIN SS		
5	86070230	140603	1	BRKT, ACTUATOR MOUNT REAR		
6	86070240	140604	1	BRKT, ACTUATOR MOUNT FRONT		
7	86008670	80606	2	COTTER, 3/8" RING		
8	86276670	70712	2	SCR, 3/8-16 X 6.0 HHCS SS		
9	86068140	140622	1	BRKT, ACTUATOR TUBE		
10	86255280	73883	4	SPRING, COMP .97 OD X 3.5 L		
11	86005840	57269	2	NUT, 3/8-16 HEX COUPLING SS		
12	86005730	57111	2	NUT, 3/8-16 HEX		
13	86233410	81270	1	CLAMP, 3/4 DIA CUSHION .406 DIA		
14	86248970	81406	1	PIN, CLEVIS 3/8 X 2		
15	86014660	-	1	ACTUATOR, 24VDC 5.0 STRK 90 DEGREE		
16	86272410	66233	1	PIN, CLEVIS 3/8" X 1.625" PLTD		
17	86069930	140547	1	BRKT, SOLUTION FILL		

SOLUTION

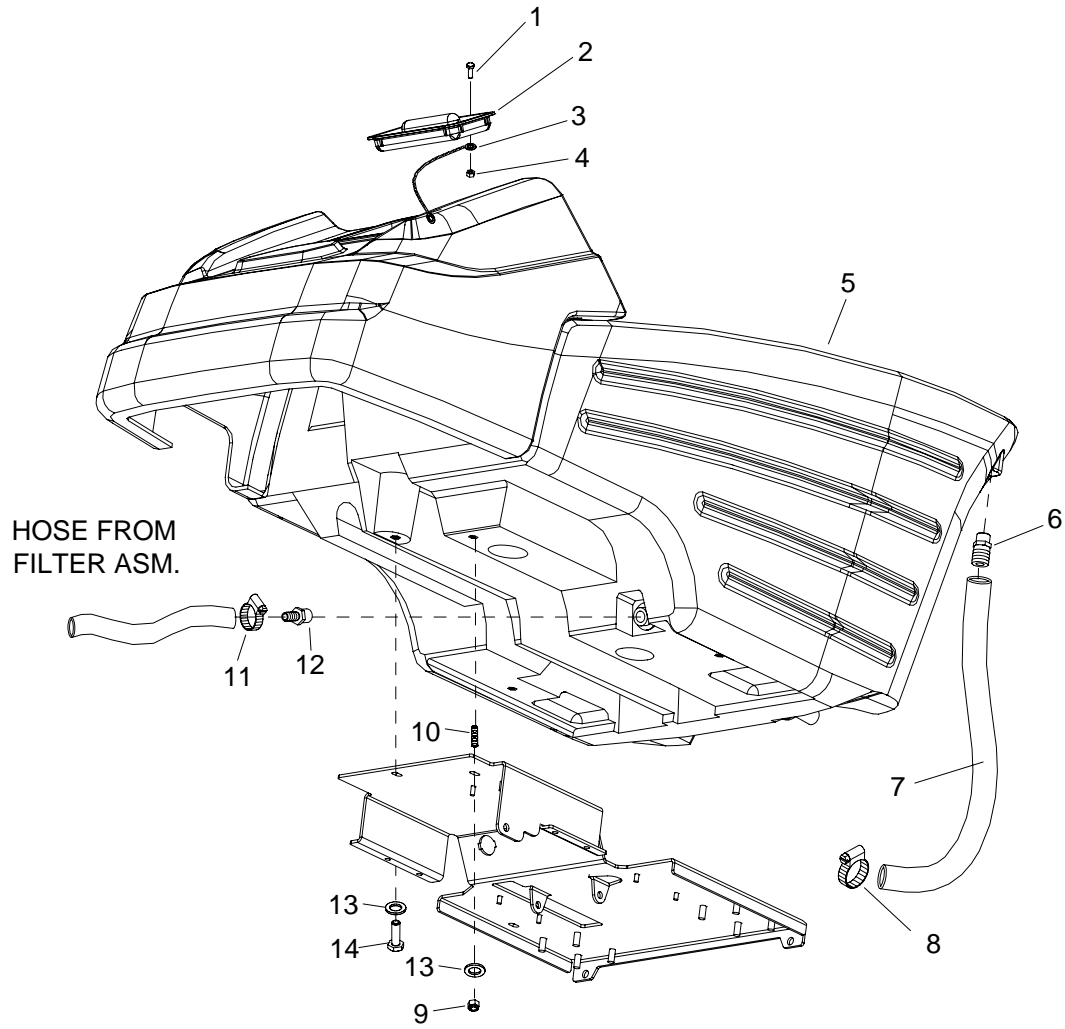

SOLUTION

REF	PART NO.	PRV NO.	QTY	DESCRIPTION	SERIAL NO. FROM	NOTES:
1	86273950	70056	1	SCR, 6-32 X 1/2 PPHMS		
2	86234790	27827	1	COVER, SOLUTION TANK		
3	86246080	51368	1	LANYARD, 18.0 W/ LOOP & EYE		
4	86014810	-	1	NUT, 6-32 ACORN SS		
5	86008270	75370	1	TANK, SOLUTION 24V		
6	86240460	40089	1	HOSEBARB, 1/2 MPT X 1		
7	86282050	39562	1	HOSE, 1.0ID 1/8W X 26 CLR		
8	86233110	20018	1	CLAMP, 1.0" WORM GEAR		
9	86271840	57285	3	NUT, 5/16-18 HEX NYLOCK THIN SS		
10	86276380	70639	3	SCR, 5/16-18 X 1.25 SSSCU		
11	86233150	20042	1	CLAMP, 3/8 HOSE (D-SLOT)		
12	86197910	40022	1	HOSEBARB, 1/2 MPT X 1/2 POLY DL		
13	86010670	87029	4	WASHER, 5/19 FLAT SS		
14	86276780	70728	1	SCR, 5/16-18 X 3/4 HHCS SS		

SOLUTION

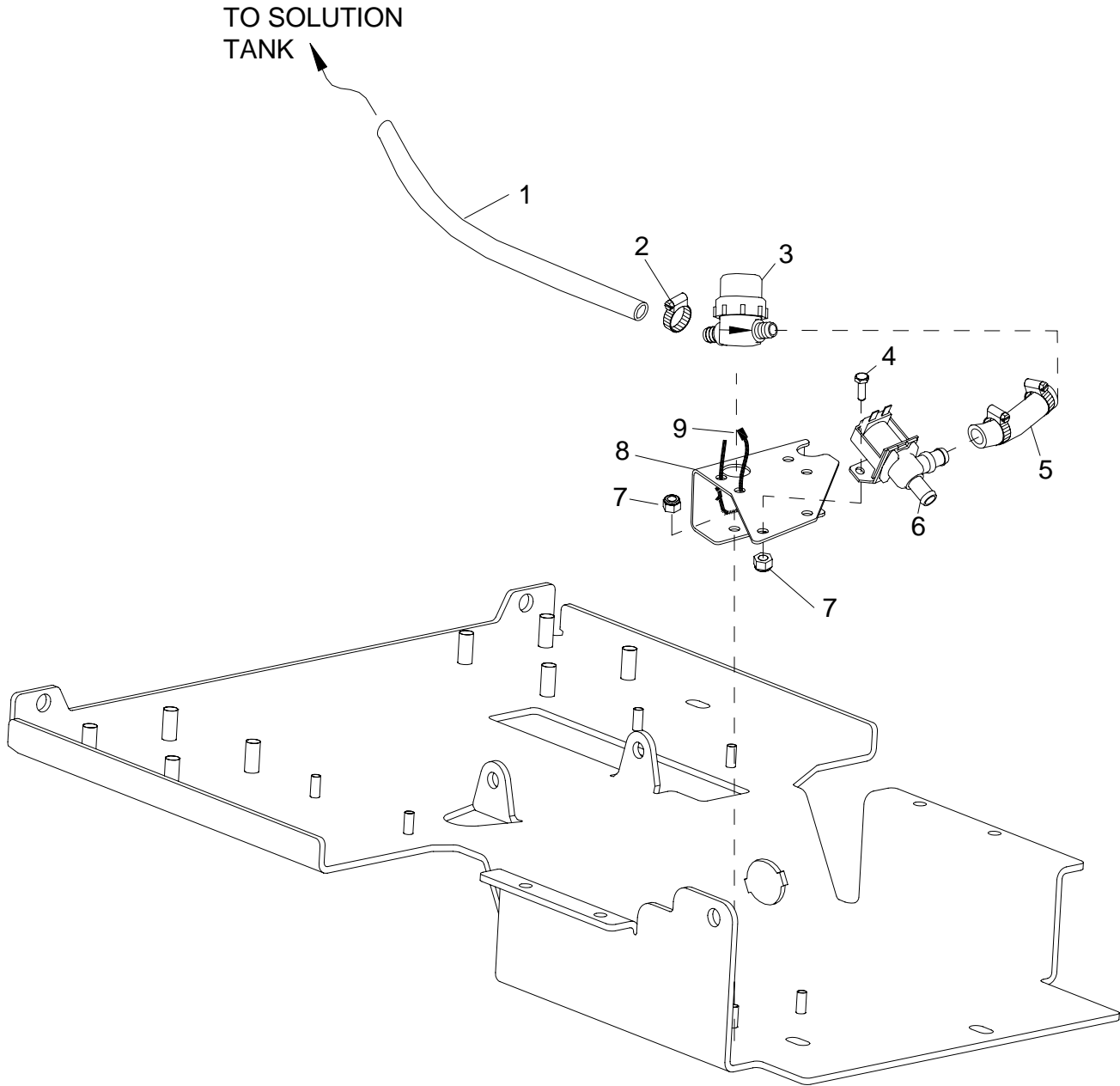

SOLUTION

REF	PART NO.	PRV NO.	QTY	DESCRIPTION	SERIAL NO. FROM	NOTES:
1	86282190	39616	1	HOSE, 1/2" WIRE BOUND X 13"		
2	86233150	20042	3	CLAMP, 3/8 HOSE (D-SLOT)		
3	86007560	730161	1	STRAINER, 1/2 HOSE 20 MESH		
-	86005870	59021	1	O-RING, FILTER SEAL RON-VIK		SRVC ONLY
-	86007750	73405	1	SCREEN, 20 MESH STRAINER		SRVC ONLY
-	86002860	27372	1	CAP, STRAINER 26/32		SRVC ONLY
4	86273750	70011	2	SCR, 1/4-20 X 5/8 HHCS SS NP		
5	86281100	39274	1	HOSE, 1/2 WIRE BOUND X 8"		
6	86010540	84141	1	VALVE, 24VDC SOL 1/2" HOSEBARB		
-	86003460	29260	-	DIAPHRAGM SRVC PART SLND		SRVC ONLY
-	86136820	47395	-	SOLENOID SPRING KIT		SRVC ONLY
7	86271870	57290	4	NUT, 1/4-20 HEX NYLOCK THIN SS		
8	86070380	140628	1	BRACKET, FILTER/SOLUTION SQZ PLAY		
9	86264940	27051	2	CABLE TIE, 11.38" UL/CSA		

SOLUTION HOSE ASM

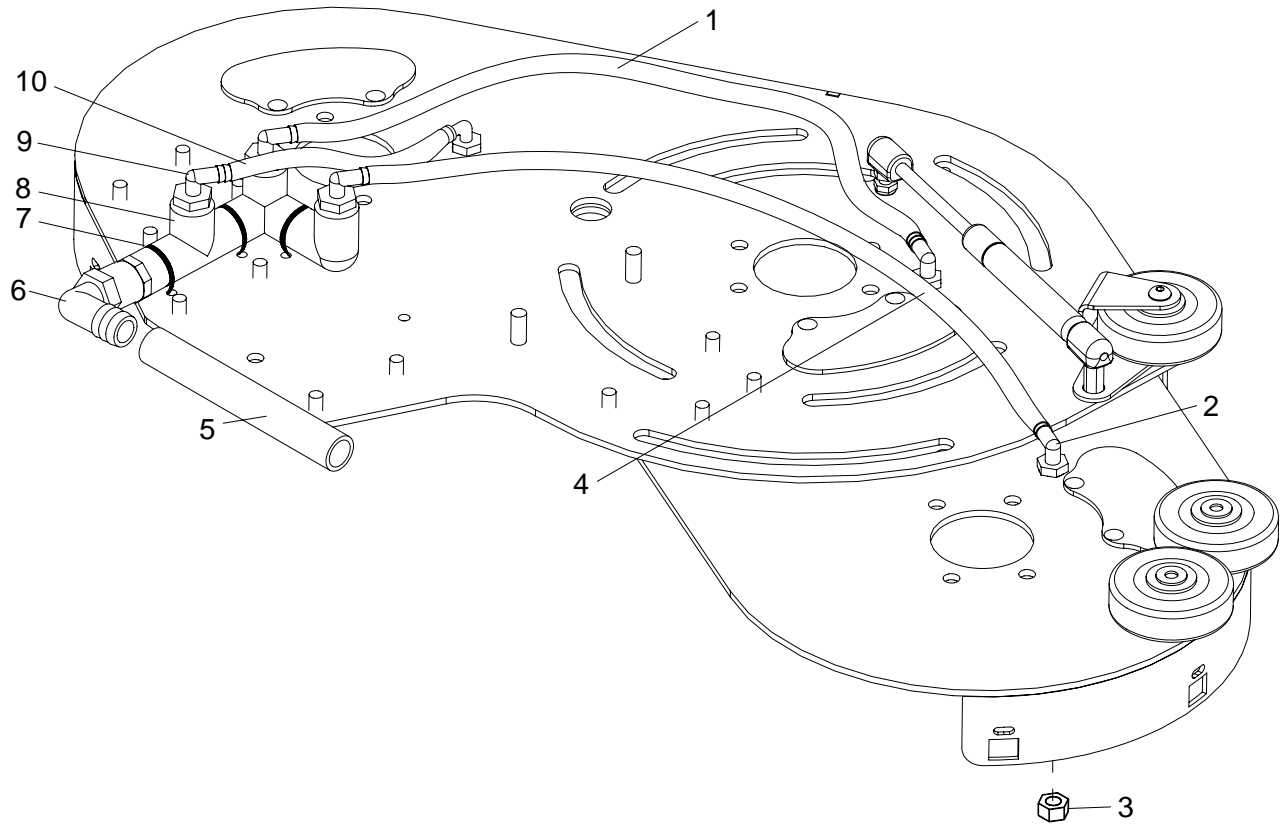

SOLUTION HOSE ASM

REF	PART NO.	PRV NO.	QTY	DESCRIPTION	SERIAL NO. FROM	NOTES:
1	86282220	39621	1	HOSE, 1/4 NYLOBRAID X 19		
2	86200280	250-12	3	HOSEBARB, 3/8 MPT X 1/4 90°		
3	86271830	57283	3	NUT, 3/8 NPT PLASTIC		
4	86282230	39622	1	HOSE, 1/4 NYLOBRAID X 29		
5	86282240	39624	1	HOSE, 1/2 WIRE BOUND X 6.0		
6	86001530	40039	1	HOSEBARB, 1/2MPT X 1/2 HOSE 90°		
7	86264940	27051	3	CABLE TIE, 11.38" UL/CSA		
8	86033220	54185	1	MANIFOLD, SOLUTION FEED SRS		
9	86198010	40093	3	HOSEBARB, 1/2MPT X 1/4 HOSE 90°		
10	86282210	39620	1	HOSE, 1/4 NYLOBRAID X 9		

SQUEEGEE - FRONT

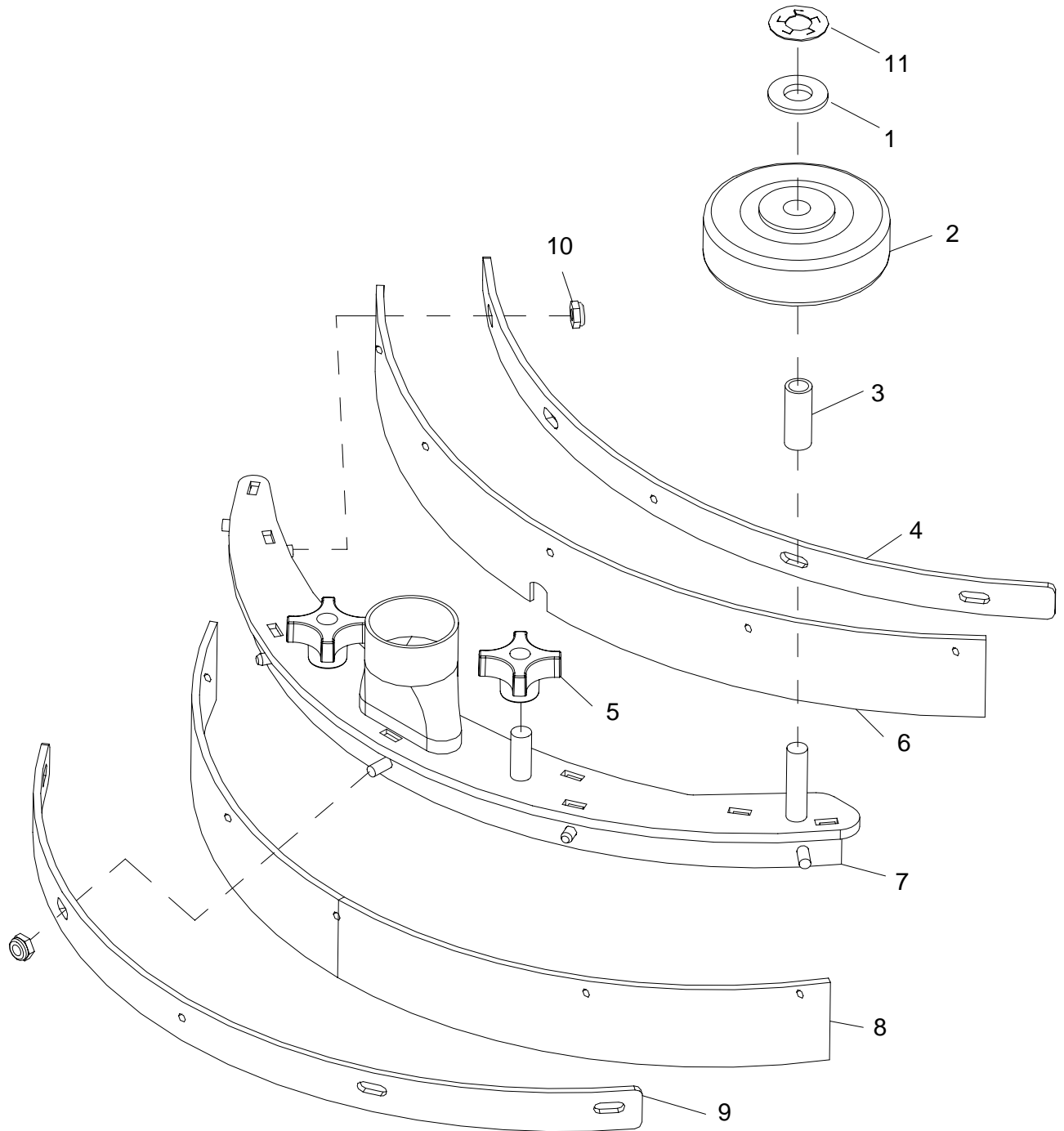

SQUEEGEE – FRONT

REF	PART NO.	PRV NO.	QTY	DESCRIPTION	SERIAL NO. FROM	NOTES:
1	86010670	87029	1	WASHER, 5/16 FLAT SS		
2	86011020	89202	1	WHEEL, 3" DIA CUSHION RUBBER		
3	86001350	140390	1	BUSHING, SPANNER .435 X 1.10		
4	86088000	730186	1	STRAP, SQUEEGEE BLADE FRONT		
5	86004790	48012	2	KNOB, 5/16-18 4 PRONG		
6	86007590	730197	1	FRONT BLADE, SIDE SQZ		
7	86094210	730182	1	WELDMENT, SIDE SQG FRAME		
8	86007600	730198	1	BACK BLADE, SIDE SQG		
9	86088010	730187	1	STRAP, SQUEEGEE BLADE BACK		
10	86271900	57294	6	NUT, 10-24 HEX NYLOCK THIN SS		
11	86279750	87252	1	WASHER, RET, PUSHNUT, 5/16 BOLT		

SQUEEGEE - REAR

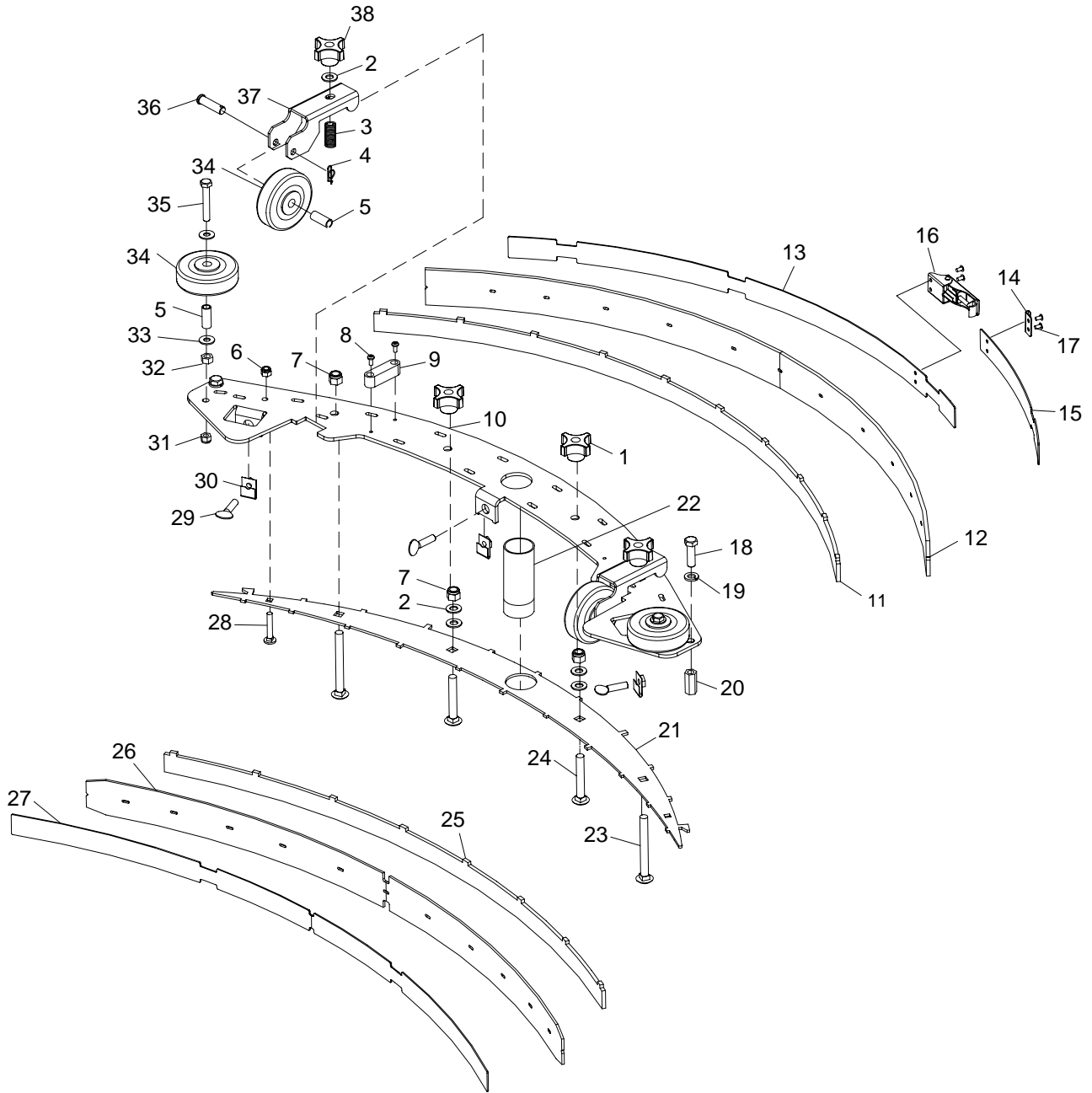

SQUEEGEE – REAR

REF	PART NO.	PRV NO.	QTY	DESCRIPTION	SERIAL NO. FROM	NOTES:
1	86009200	81535	2	KNOB, 3/8-16 4 PRONG		
2	86010680	87030	6	WASHER, 3/8 X 3/4 NYLON		
3	86007780	73576	2	SPRING, COMP .60D X 2.0L X .045W		
4	86008660	80605	2	COTTER, 5/16 RING		
5	86001350	140390	4	BUSHING, SPANNER .435 X 1.10		
6	86271870	57290	2	NUT, 1/4-20 HEX NYLOCK THIN SS		
7	86005630	57022	4	NUT, 3/8-16 HEX NYLOCK THIN SS		
8	86274130	70098	2	SCR, 8-32 X 3/8 PHTC 'F' PLTD		
9	86009910	82576	1	VIAL, LEVEL		
10	86082420	62970	1	PLATE, SQUEEGEE TOP 35"		
11	86082440	62972	1	PLATE, REAR SQUEEGEE 35"		
12A	86007430	730114	1	SQUEEGEE, REAR BLADE LINATEX		
12B	86137020	730423	1	SQUEEGEE, REAR BLADE URETHANE		
13	86001340	140384	1	BAND, REAR SQUEEGEE		
14	86009180	81489	1	STRIKER, SQUEEGEE STRAP REAR		
15	86001330	140382	1	BAND, REAR SQUEEGEE		
16	86009170	81488	1	LATCH, SQUEEGEE STRAP		
17	86006400	67380	4	RIVET, 5/32OD X 1/8 GRIP		
18	86276920	70755	2	SCR, 3/8-16 X 1 HHCS SS NP		
19	86010790	87163	2	WASHER, 3/8 SPLIT		
20	86005840	57269	2	NUT, 3/8-16 HEX COUPLING SS		
21	86082450	62973	1	PLATE, SQUEEGEE BOTTOM 35"		
22	86008390	78493	1	TUBE ASM, SQUEEGEE VAC		
23	86276990	70776	2	SCR, 3/8-16 X 3.5 CARRIAGE SS		
24	86276870	70748	2	SCR, 3/8-16 X 2.5 CARRIAGE SS		
25	86082430	62971	1	PLATE, SQUEEGEE FRONT 35"		
26A	86008020	73894	1	BLADE, SQUEEGEE FRONT LINATEX		
26B	86137030	730424	1	SQUEEGEE, FRONT BLADE URETHANE		
27	86066370	140383	1	STRAP, SQUEEGEE		
28	86277000	70777	2	SCR, 1/4-20 X 1.5 CARRIAGE SS		
29	86007040	70680	3	SCR, 5/16-18 X 1 THUMB SS TYPE P		
30	86271820	57270	3	NUT, 5/16-18 CAPTIVE "J" PLTD		
31	86271840	57285	2	NUT, 5/16-18 HEX NYLOCK THIN SS		
32	86005650	57031	2	NUT, 5/16-18 HEX		
33	86010670	87029	4	WASHER, 5/16 X 3/4 SS		
34	86011020	89202	4	WHEEL, 3" DIA. CUSHION RUBBER		
35	86276980	70775	2	SCR, 5/16-18 X 2.00 HHCS SS		
36	86006270	66276	2	PIN, CLEVIS 5/16 X 1.63		
37	86069870	140531	2	BRACKET, SQUEEGEE WHEEL		
38	86004890	48095	2	KNOB, ALUM 3/8-16 NYLOCK NUT SS		
39	86026530	47398	-	SQUEEGEE 26 IN SCRUBHEAD		SRVC ASM

SQUEEGEE LIFT LINKAGE (LOWER)

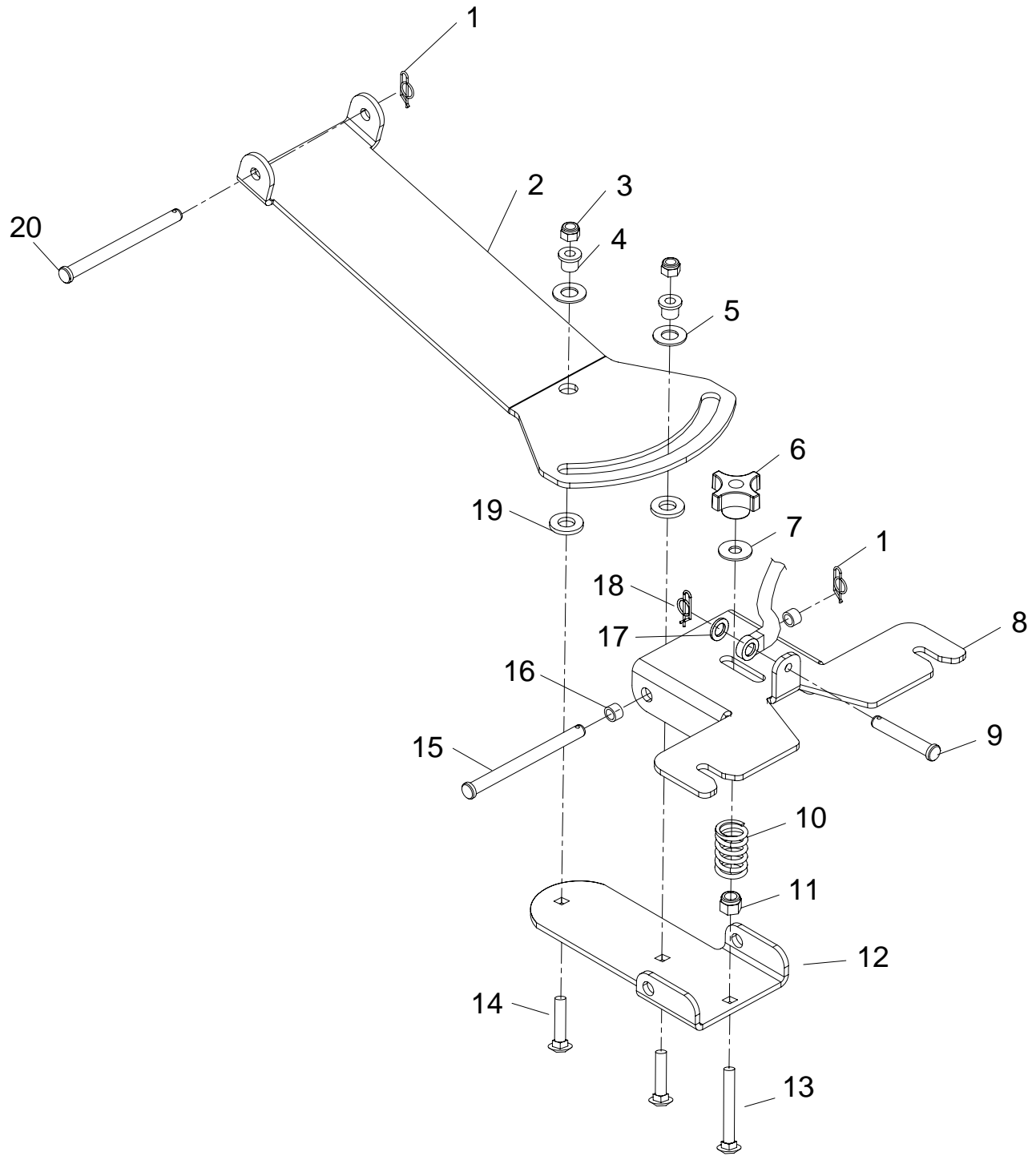

SQUEEGEE LIFT LINKAGE (LOWER)

REF	PART NO.	PRV NO.	QTY	DESCRIPTION	SERIAL NO. FROM	NOTES:
1	86008670	80606	2	COTTER, 3/8" RING		
2	86069450	140455	1	BRACKET, SQG PIVOT LIFT		
3	86271840	57285	2	NUT, 5/16-18 HEX NYLOCK THIN SS		
4	86228840	09124	2	BEARING, FLANGED .314ID X .502OD		
5	86259420	87232	2	WASHER, THRUST .51ID X 1ODBRO		
6	86009200	81535	1	KNOB, 3/8-16 4 PRONG ALUM		
7	86279510	87171	1	WASHER, 3/8 FLAT		
8	86082150	62922	1	PLATE, SQUEEGEE MOUNT		
9	86009560	82053	1	PIN, CLEVIS 1/4 X 5/8" PLTD		
10	86007270	730006	1	SPRING, COMP 1.10OD X 2.0L X .148W		
11	86005630	57022	1	NUT, 3/8-16 HEX NYLOCK THIN SS		
12	86072530	14409	1	BRACKET, CAMBER PIVOT		
13	86276870	70748	1	SCR, 3/8-16 X 2.50 CARRIAGE SS		
14	86277130	70795	2	SCR, 5-16-18 X 1.00 CARRIAGE SS		
15	86249060	82061	1	PIN, CLEVIS 3/8 X 4.63 PLTD		
16	86008870	80815	2	BEARING, FLANGED 3/8" ID X 11/16"		
17	86010630	87013	1	WASHER, 1/4 ID X 5/8 OD SS		
18	86008650	80604	1	COTTER, 1/4" RING		
19	86259400	87205	2	WASHER, THRUST .51ID X 1OD BRO		
20	86008860	80808	1	PIN, CLEVIS 3/8" X 5.5"L PLTD		

FRONT SQUEEGEE LINKAGE

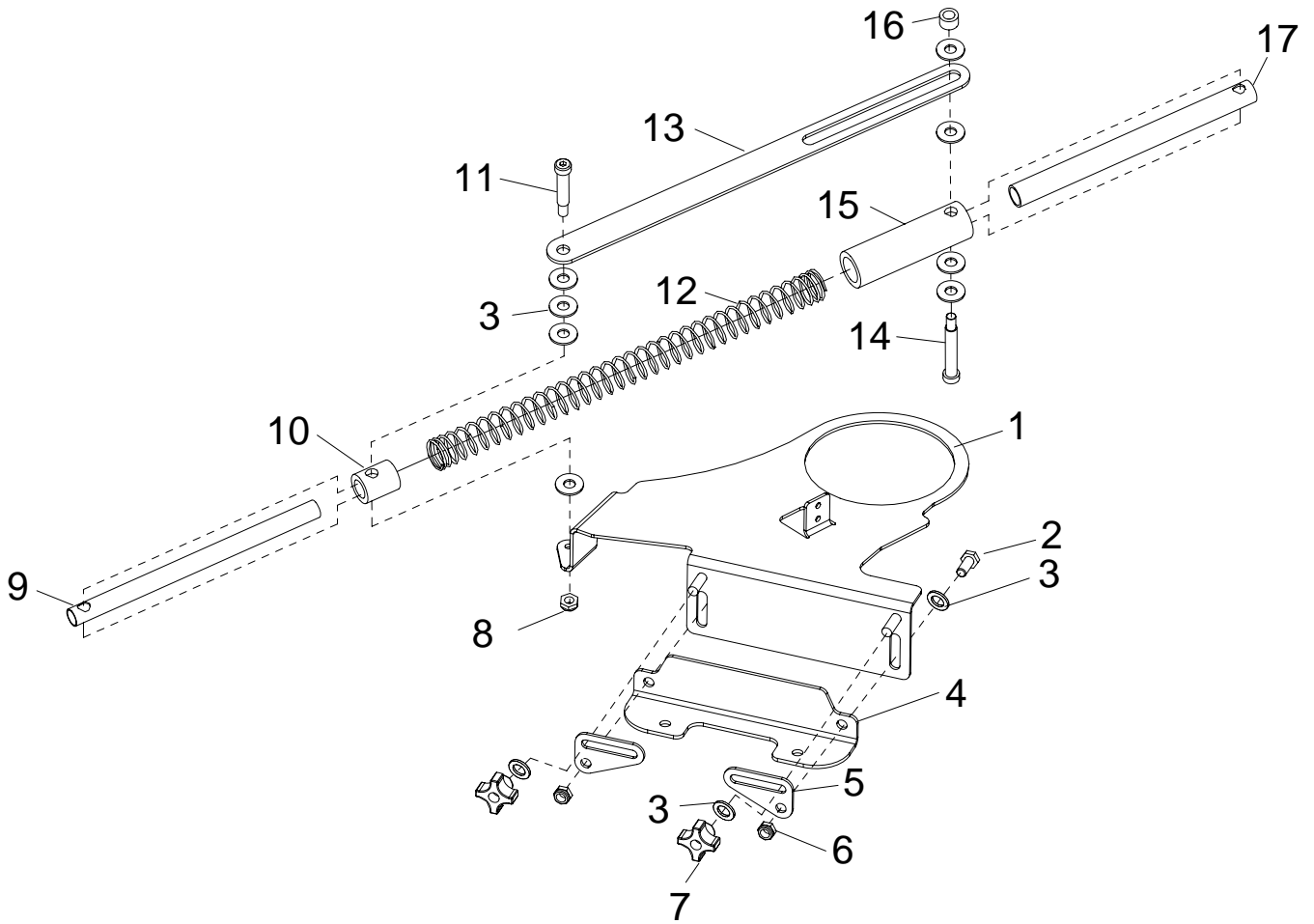

FRONT SQUEEGEE LINKAGE

REF	PART NO.	PRV NO.	QTY	DESCRIPTION	SERIAL NO. FROM	NOTES:
1	86070250	140605	1	BRKT, SIDE SQG PIVOT		
2	86276780	70728	2	SCR, 5/18-18 X 3/4 HHCS SS		
3	86010670	87029	11	WASHER, 5/16 FLAT SS		
4	86077500	51384	1	LINKAGE, SIDE SQG		
5	86082970	66390	2	PLATE, SIDE SQG ADJ		
6	86271840	57285	2	NUT, 5/16-18 HEX NYLOCK THIN SS		
7	86004790	48012	2	KNOB, 5/16-18 4 PRONG		
8	86271870	57290	2	NUT, 1/4-20 HEX NYLOCK THIN SS		
9	86089700	78540	1	TUBE, 1/2 OD X .035 WALL SS		
10	86078480	66395	1	PIPE, 1/2 SCH 80 X 1.02 PVC		
11	86278190	70267	1	SHOULDER BOLT, 5/16 OD X 1.25		
12	86254950	730204	1	SPRING, COMP .875 OD X 12 L X .062W		
13	86066880	140626	1	BAR, SIDE SQG SPRING STRUT		
14	86278370	70803	1	SHOULDER BOLT, 5/16 OD X 1.75 SS		
15	86078470	66394	1	PIPE, 3/4 SH80 X 3.52 PVC		
16	86224290	730008	1	SPACER, .317 ID X .5 OD X .44 LG		
17	86089690	78539	1	TUBE, 5/8OD X /058 WALL SS		

VACUUM

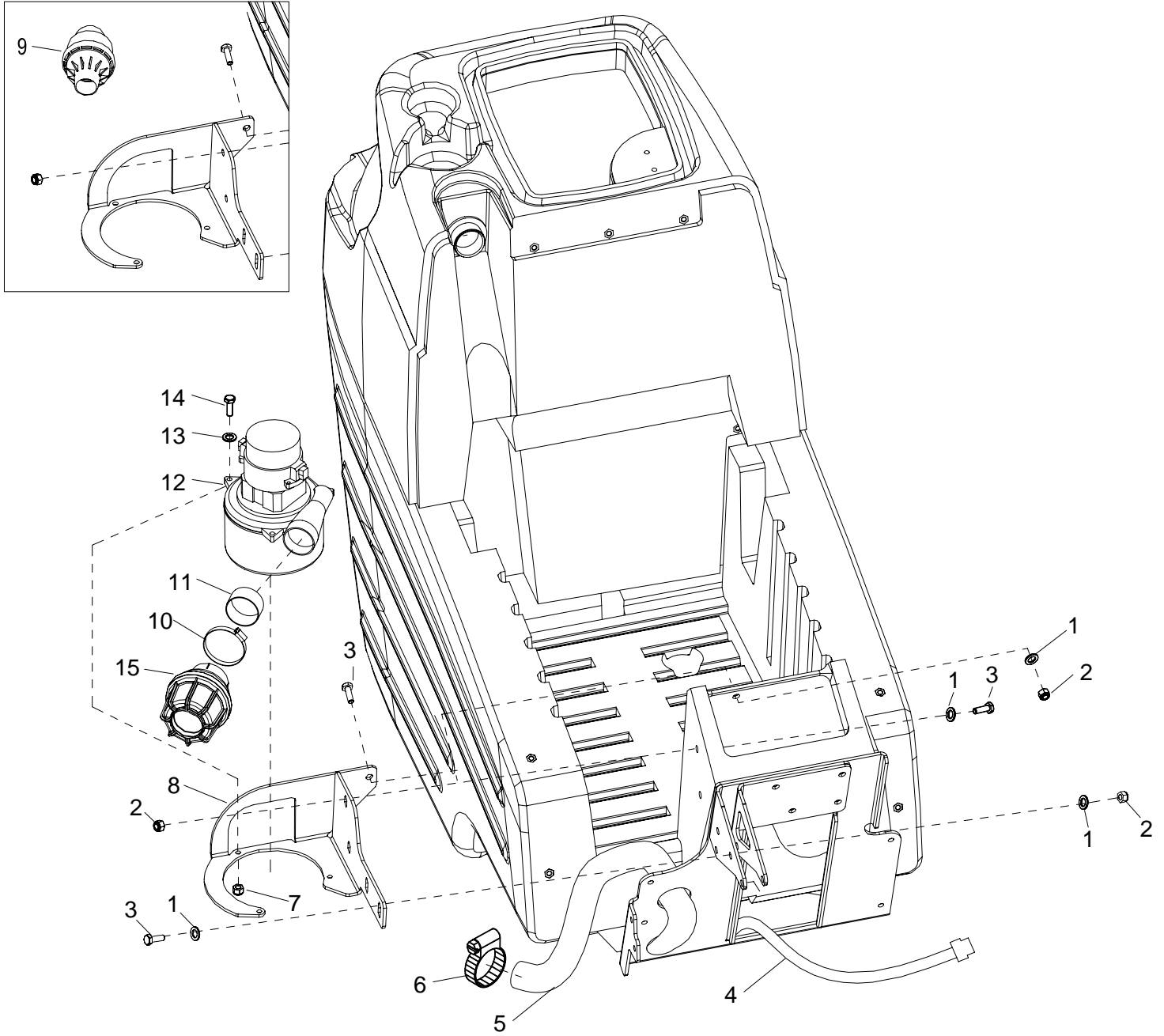

VACUUM

REF	PART NO.	PRV NO.	QTY	DESCRIPTION	SERIAL NO. FROM	NOTES:
1	86278910	87003	7	WASHER, 3/8ID X 7/8OD SS		
2	86005630	57022	5	NUT, 3/8-16 HEX NYLOCK THIN SS		
3	86276920	70755	5	SCR, 3/8-16 X 1 HHCS SS NP		
4	86004250	39417	1	HOSE, 1.0 BLK VAC X 8 FT		
5	86001620	40087	1	HOSE ASM, 1.5 BLK VAC X 67		
6	86002400	20064	2	CLAMP, 2.0" WORM GEAR X .312W		
7	86271870	57290	3	NUT, 1/4-20 HEX NYLOCK THIN SS		
8	86070370	140623	1	BRKT, VAC MOTOR MOUNT		NOT AVAIL
9	86120190	54186	1	MUFFLER, WALK BEHIND SCRUBBER		
10	86233430	81431	1	CLAMP, 2.50 WORM GEAR		
11	86091170	730174	1	TUBE, 2.0 OD X .05W X 1.0L		
12	86005460	53801	1	VAC MOTOR ASM, 24VDC 3 STAGE		
-	86230810	140551	-	BRUSH SET, 24V 3 ST VAC AMETEK		SRVC ONLY
-	86135310	140686	-	BRUSH SET, 24V/36V VAC WINDSOR	1000122411	SRVC ONLY
13	86010630	87013	3	WASHER, 1/4ID X 5/8OD SS		
14	86273810	70018	3	SCR, 1/4-20 X 1 HHCS SS		
15	86064910	54194	1	MUFFLER, VAC MOTOR	1000122451	

WHEELS AND FRAME

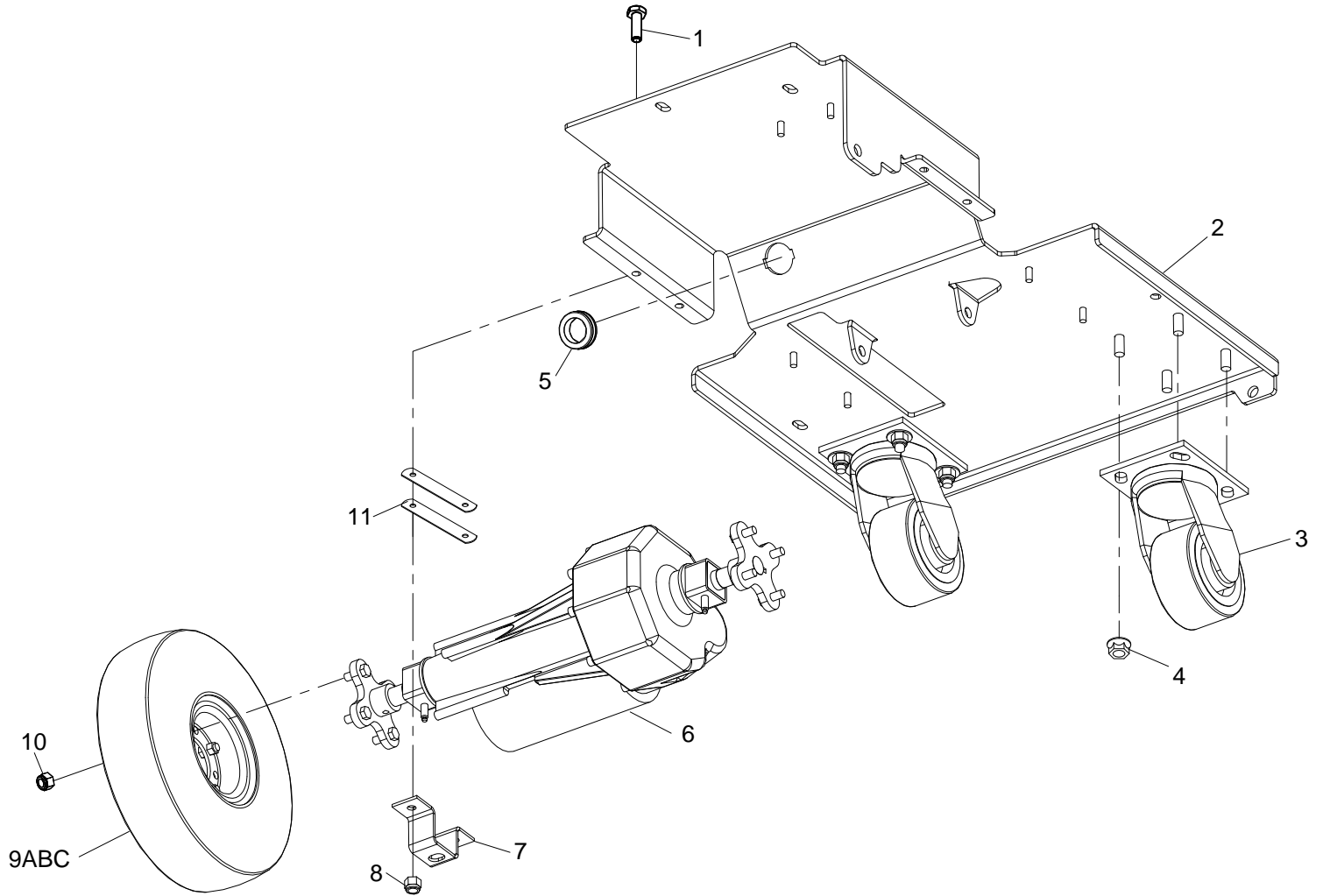

WHEELS AND FRAME

REF	PART NO.	PRV NO.	QTY	DESCRIPTION	SERIAL NO. FROM	NOTES:
1	86006560	70083	4	SCR, 5/16-18 X 1 HHCS SS NP		
2	86075870	34402	1	FRAME, MAIN SQZ PLAY		
3	86002310	18041	2	CASTER, 4 DIA X 2W X 3.56R		
4	86270880	57032	8	NUT, 3/8-16 SERRATED FLG		
5	86238430	36191	1	GROMMET, 1.OOID 3/16 GRIP		
6	86000800	05128	1	AXLE MOTOR DRIVE, 24VDC		
-	86216150	140588	-	BRUSH SET, 24V TRANSAXLE		SRVC ONLY
-	OBSOLETE	47271	-	HUB KIT, 05128 TRANSAXLE		SRVC ONLY
-	86241840	48091	-	KEY, WOODRUFF .75ID HUB		SRVC ONLY
7	86230330	14369	2	BRACKET, TRANSAXLE MOUNT		
8	86271840	57285	4	NUT, 5/16-18 HEX NYLOCK THIN SS		
9A	86011050	89212	2	WHEEL ASM, 10" FMFL BLK KNOBBY		
9B	86137420	830748	-	WHEEL ASM, 10" SOLID SPCL SCBR		OPTIONAL
9C	86011040	89211	-	WHEEL ASM, 10" FMFL N-MARKING		OPTIONAL
10	86271860	57289	8	NUT, 5/16-24 HEX NYLOCK SS		
11	86081870	62844	4	PLATE, TRANSAXLE SPACER		

WIRING- BATTERY

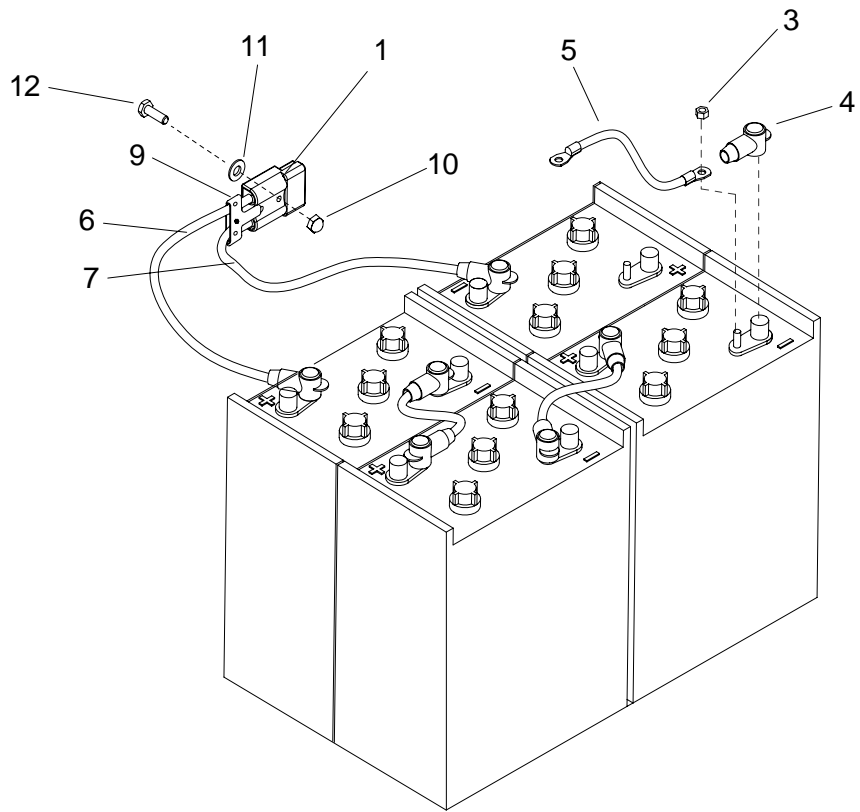
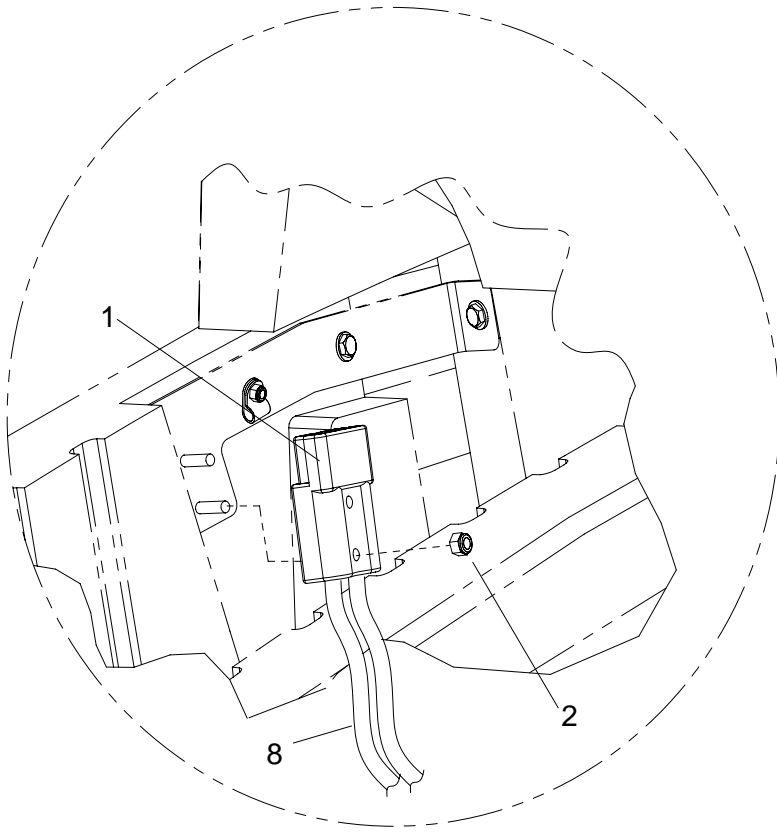

WIRING-BATTERY

REF	PART NO.	PRV NO.	QTY	DESCRIPTION	SERIAL NO. FROM	NOTES:
1	86010120	82803	2	CONNECTOR, RED 24V		
2	86271870	57290	2	NUT, 1/4-20 HEX NYLOCK THIN SS		
3	86271910	57295	8	NUT, 5/16-18 FLEXLOCK		
4	86008920	80889	8	BOOT, RUBBER TERM. ISOLATOR		
5	86009000	81131	3	WIRE, 4 X 9.5 BK 5/16 RING X 5/16 RING		
6	86010850	880352	1	WIRE, 4X20 RD C, TERM X 5/16 RING		
7	86010860	880353	1	WIRE, 4X20 BK C, TERM X 5/16 RING		
8	86260520	880384	2	WIRE, 4X67 BK C. TERM 5/16 RING		
9	86233360	28038	1	CLAMP, CABLE KIT SY945		
10	86270890	57034	1	NUT, ACORN 10-32		
11	86010650	87018	1	WASHER, #10 X 9/16 OD		
12	86273980	70066	1	SCR, 10-32 X 3/4 PPHMS SS		

WIRING – CONTROL PANEL

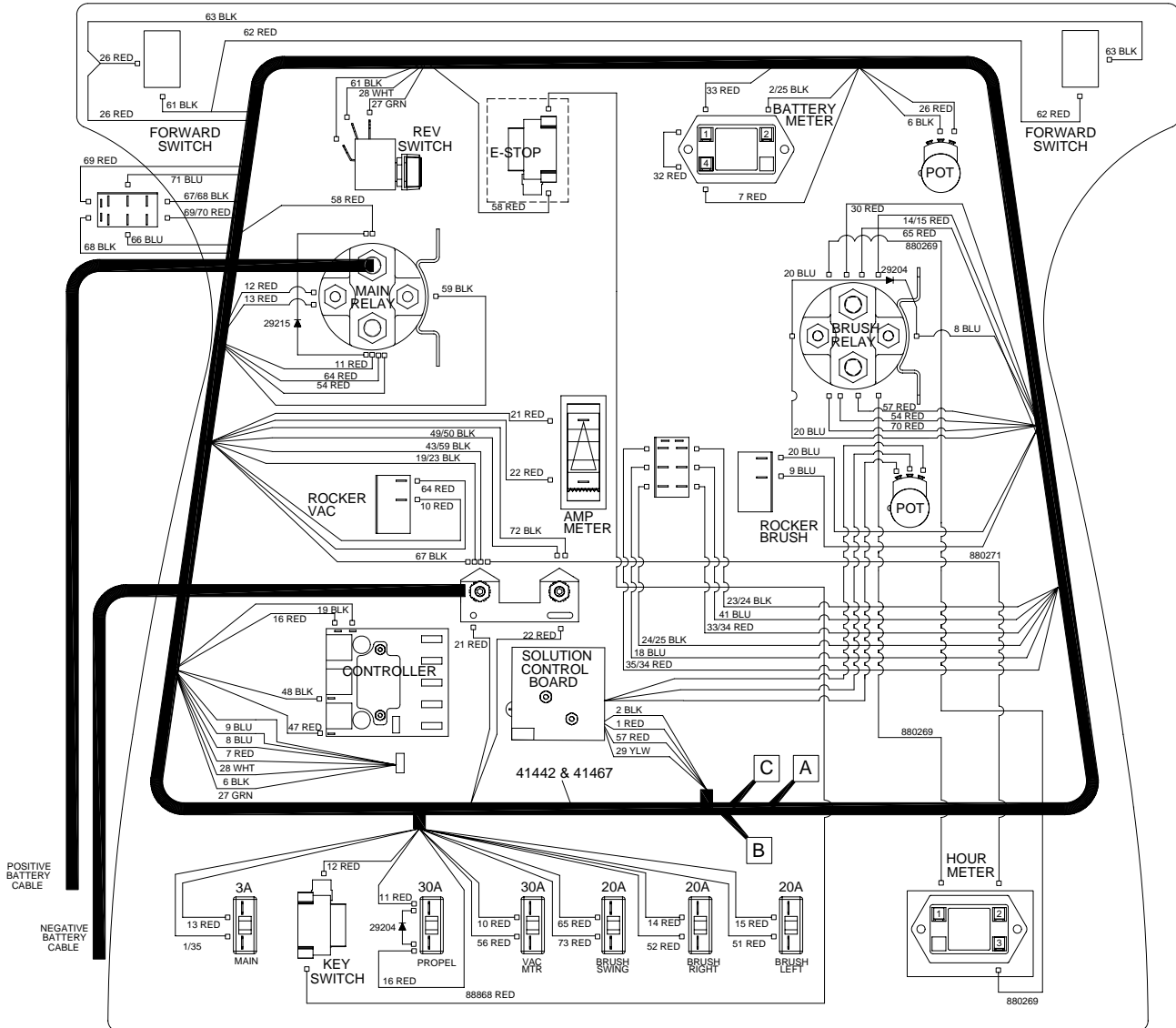
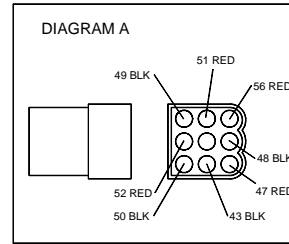
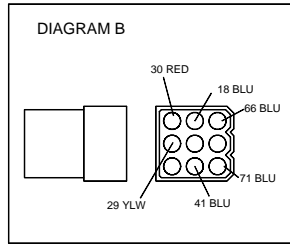
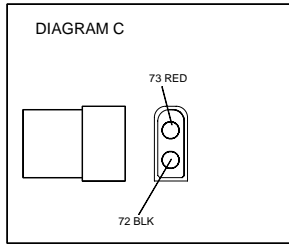

 INDICATES OPTIONAL ACCESSORY

WIRING-CONTROL PANEL

REF	PART NO.	PRV NO.	QTY	DESCRIPTION	SERIAL NO. FROM	NOTES:
1	86239040	41467	1	HARNESS, PANEL CUTTER 36"		
2	86238990	41442	1	HARNESS, PANEL DLX		
3	86261210	29204	2	DIODE ASM, 79008 X 76008		
4	86003410	29215	1	DIODE ASM, 76075 X 76075		

WIRING – MAIN HARNESS

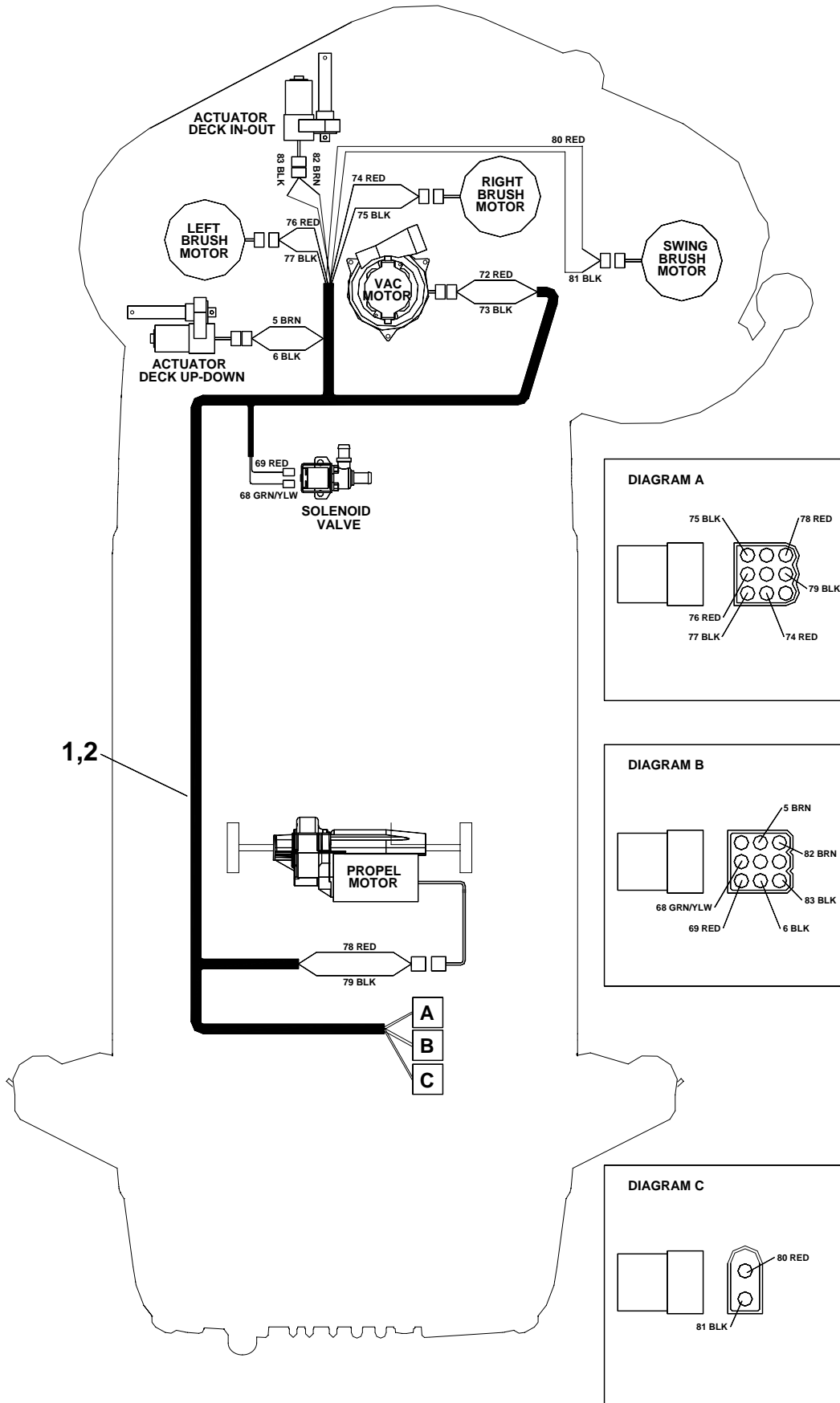

WIRING-MAIN HARNESS

REF	PART NO.	PRV NO.	QTY	DESCRIPTION	SERIAL NO. FROM	NOTES:
1	86239030	41466	1	HARNESS, MAIN CUTTER 36"		
2	86238980	41441	1	HARNESS, MAIN		

WIRING - SCHEMATIC

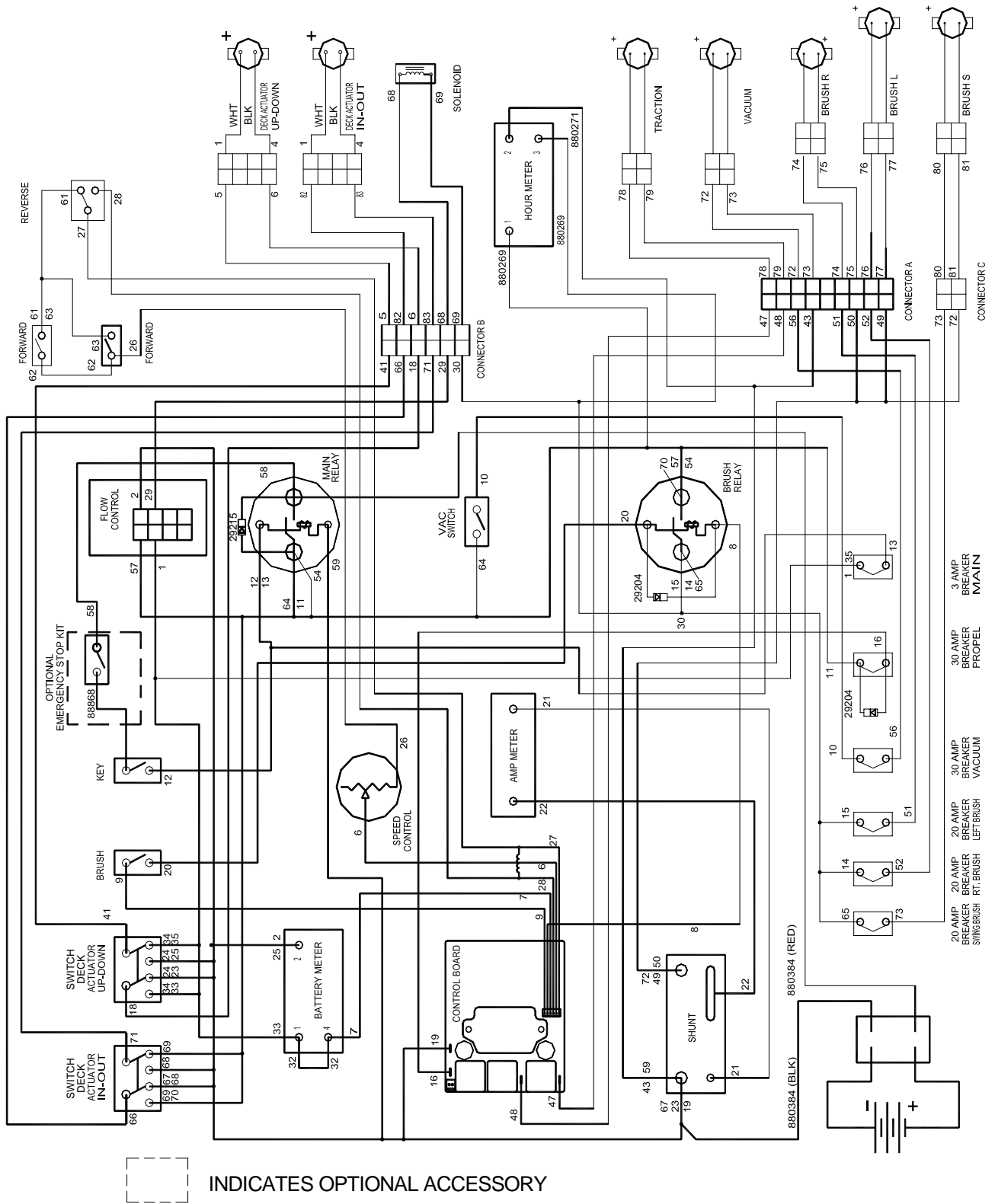

CUTTER *SABER™*

OPTIONS

BRAKE-OPTION

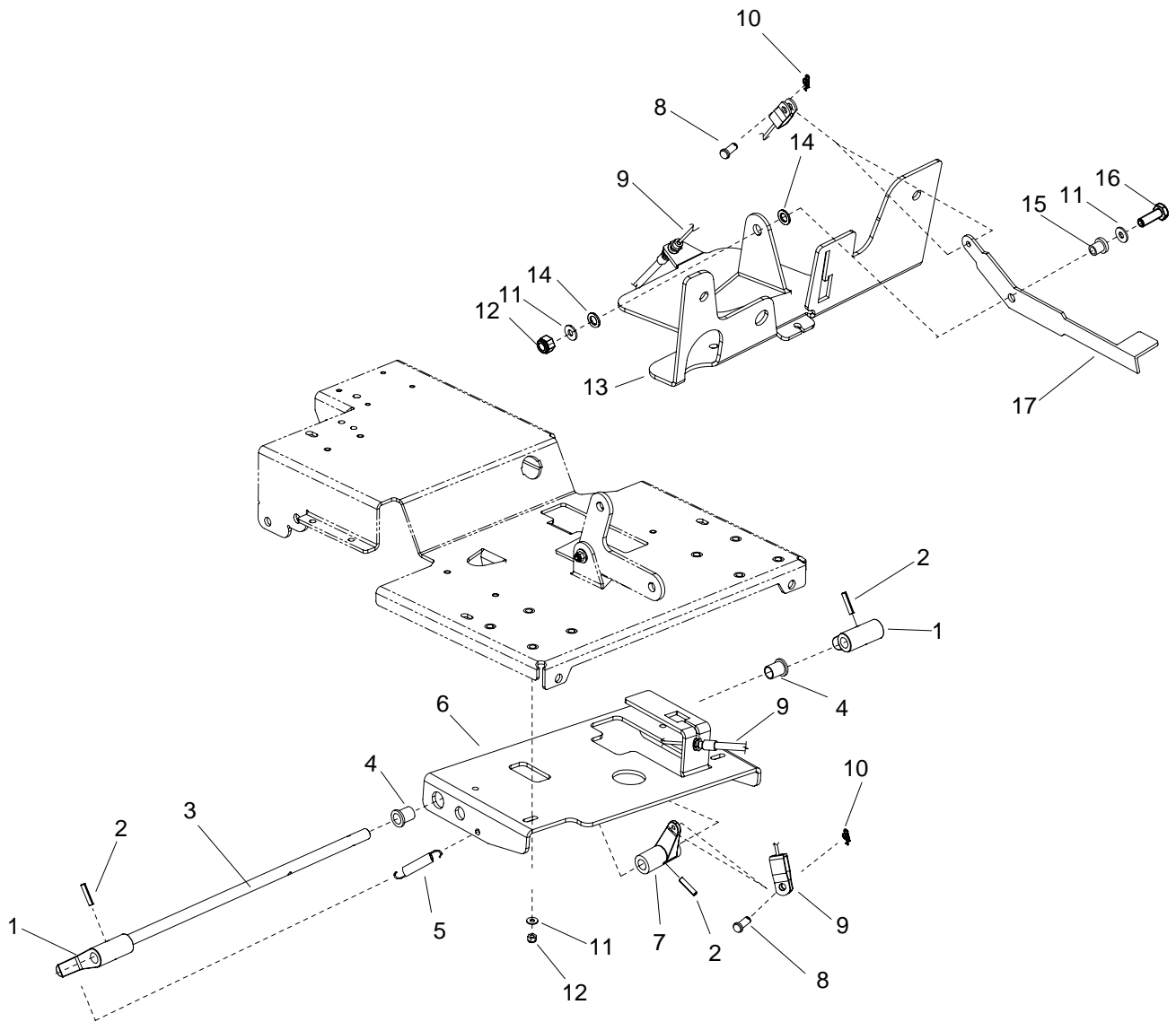

BRAKE-OPTION

REF	PART NO.	PRV NO.	QTY	DESCRIPTION	SERIAL NO. FROM	NOTES:
1	86248370	66381	2	PAD, BRAKE		
2	86006220	66192	3	PIN, ROLL 1/4 X 1.25L		
3	86252070	67486	1	ROD, BRAKE 24V		
4	86231330	14664	2	BUSH, BRZ FLG .63 X .75 X 1.0		
5	86255060	73426	2	SPRING, EXT .43D X 2.50 L X .047 W		
6	86070070	140565	1	BRKT, LOWER BRAKE MOUNT 24V		
7	86234850	27956	1	CRANK, BRAKE		
8	86272610	80669	2	PIN, CLEVIS 5/16" X 3/4" L PLTD		
9	86231820	27961	1	CABLE, PARK BRAKE		
10	86008660	80605	2	COTTER, 5/16" RING		
11	86010630	87013	6	WASHER, 1/4 ID X 5/8 OD SS		
12	86271870	57290	5	NUT, 1/4-20 HEX NYLOCK THIN SS		
13	86070150	140574	1	BRKT, TANK MOUNT 24V		
14	86259400	87205	2	WASHER, THRUST .51 ID X 1 OD BRO		
15	86228900	09138	1	BEARING FLANGED .252 ID X .503OD		
16	86273820	70019	1	SCR, 1/2-20 X 1.25 HHCS		
17	86077280	51378	1	LEVER, BRAKE		

EMERGENCY STOP-OPTION

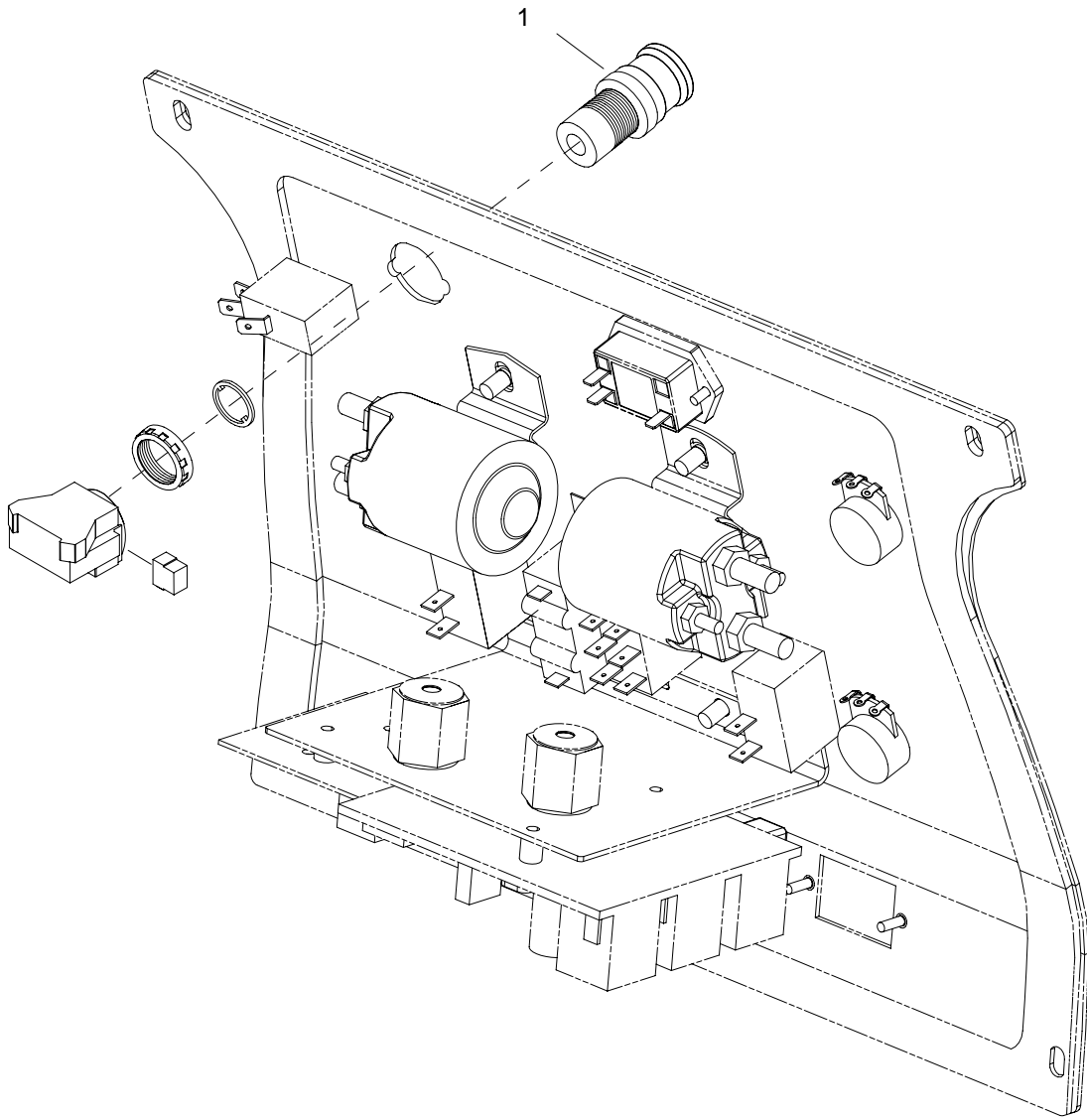

EMERGENCY STOP-OPTION

REF	PART NO.	PRV NO.	QTY	DESCRIPTION	SERIAL NO. FROM	NOTES:
1	86007180	72160	1	SWITCH, EMERGENCY STOP		
2	86269300	88868	1	WIRE, 16" RED/18 STRIP X STRIP		NOT SHOWN

SUGGESTED SPARE PARTS

PART NO.	PRV NO.	DESCRIPTION	SERIAL NO. FROM	NOTES:
86001910	14606	BREAKER, 30A 50VDC		
86230070	140634	BREAKER, 20A THERMAL CIRCUIT		
86002000	14717	BREAKER, 3A		
86230810	140551	BRUSH SET, 24V 3ST VAC AMETEK		
86135310	140686	BRUSH SET, 24V/36V VAC WINDSOR	1000122411	
86006420	67393	RELAY, 24VDC 100A		
86007140	72130	SWITCH, SPST 2-POSITION ROCKER		
86009200	81535	KNOB, 3/8-16 4 PRONG		
86007430	730114	BLADE, SQUEEGEE REAR		
86008020	73894	BLADE, SQUEEGEE FRONT		
86003990	35250	GASKET, DOME		
86236410	34394	FLOAT, VAC SHUT OFF		
86004860	48073	KEY, SWITCH		
86253970	730200	SKIRT, 3.5 X 40 EXT		
86253980	730201	SKIRT, 3.5 X 34 EXT		
86007590	730197	FRONT BLADE, SIDE SQG		
86007600	730198	BACK BLADE, SIDE SQG		
86237650	35219	GASKET, 1-1/2 COMPRESSION		
86004790	48012	KNOB, 5/16-18 4 PRONG		
86004890	48095	KNOB, ALUM 3/8-16 NYLOCK NUT SS		
86006240	66227	PLUG, DRAIN HOSE		
86007170	72159	SWITCH, KEY TWO POSITION		
86007210	72165	SWITCH, DPDT 3-POSITION ROCKER		
86257030	72168	SWITCH, MOMENTARY DPST		
86257080	72178	SWITCH, DPDT ROCKER W/ PADDLE		
86007560	730161	STRAINER, 1/2 HOSE 20 MESH		
86254930	730181	SPRING, GAS 9.6 300 NEWTONS		
86004180	39315	HOSE, 1.5 BLK VAC X 28"		
86004250	39417	HOSE, 1.0 BLK VAC X 8 FT		
86010540	84141	VALVE, 24VDC SOL 1/2" HOSEBARB		
86011020	89202	WHEEL, 3" DIA CUSHION RUBBER		

NOTES



Manufacturers of Innovative Building Maintenance Equipment

Windsor Industries, Inc.
1351 West Stanford Avenue
Englewood, CO 80110 USA

Phone: 303.762.1800
FAX: 303.762.0817
<http://www.windsorind.com>

EC Declaration of Conformity

We herewith declare, Windsor Industries, Inc.
1351 W. Stanford Ave.
Englewood, CO 80110-5545 USA

that the following product complies with the appropriate essential health and safety requirements of the relevant EC Directives listed below, based on the relevant sections of the applicable EC standards and other normative documents.

Product: Saber Cutter Deluxe 364
Product Identification: Rated 24 VDC 80 A

Trademark:

Model/Type Ref.: SCX364

Product Description: This product is a battery powered, self-propelled, wet floor scrubber intended for commercial use.

Applicable EC Directives: EC Machinery Directive
(89/392/EEC & 91/368/EEC & 93/44/EEC & 93/68/EEC)
EC Low Voltage Directive
(73/23/EEC & 93/68/EEC)
EC Directive of Electromagnetic Compatibility
(89/336/EEC & 93/68/EEC)

Applicable Harmonized Standards: EN 60335-1: 1991
EN 60335-2-67: 1992
EN 60335-2-72: 1995
EN 55022: 1998-09
EN 55011: 1998-05
EN 61000-6-2: 1999
EN 61000-4-2: 1995
EN 61000-4-3: 1997

Authorized Signature

2/17/03
Date

Title of Signature: Vice President, Windsor Industries, Inc.

QUEST
...for Continuous Improvement.
Windsor's Quality Management System is Certified ISO 9001.