



E83039-00



GENIE™ B APS

14" All Purpose
Automatic Scrubber



Operator and Parts
Manual

TABLE OF CONTENTS

RECEIVING THE MACHINE.....	3
TECHNICAL SPECIFICATIONS.....	4
GENERAL SAFETY REGULATIONS.....	5
MACHINE PREPARATION.....	6 - 11
OPERATION	12
TURNING OFF THE MACHINE	13
DAILY MAINTENANCE.....	14 - 15
SCHEDULED MAINTENANCE	16
TROUBLESHOOTING GUIDE.....	17
BRUSH AND SELECTION GUIDE.....	18
PARTS DIAGRAMS AND LISTINGS.....	20 - 37
WARRANTY	40

RECEIVING THE MACHINE



Immediately check, when receiving the machine, that all the materials indicated on delivery documents have been received and also that the machine has not been damaged in transit. If it has been damaged, this damage must be immediately reported to the shipper and also to our customer's service department. Only acting promptly in this manner will make it possible to receive missing material and to be compensated for damage.

INTRODUCTION

This is an automatic scrubber which, via the mechanical action of the rotating brush and the chemical action of a water/detergent solution, can clean any type of hard flooring. As it advances, it also collects the dirt removed and the detergent solution not absorbed by the floor.

The machine must be used only for this purpose. Even the best machines will only work well if used correctly and kept in good working order. We therefore suggest you read this instruction booklet carefully and re-read it whenever difficulties arise while using the machine. If necessary, remember that our assistance and customer service is always available for advice or direct intervention.

Serial # Plate

			
Production Year 2010	Power Source 12 Volt DC		Battery Weight lbs
Max. Op. Gradient 2%	Power Consumption 42 Amps		Machine Weight lbs
Model Name GENIE B APS		Part Number: E83039-00	
		S/N	<input type="text"/>

SYMBOLS USED ON THE MACHINE

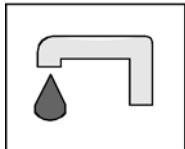

Valve symbol

Used to indicate the solenoid valve switch



Power symbol

Used to indicate the machine's power is on

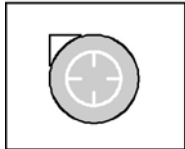

Vacuum motor symbol

Used to indicate the vacuum motor switch



Maximum solution temperature gauge

Located near the solution tank inlet

TECHNICAL DESCRIPTION	Measurement Unit	Genie™ B
Working width	in (mm)	13.8 (350)
Rear squeegee width	in (mm)	17.3 (440)
Work capacity	ft ² /h (m ² /h)	11,300 (1050)
Water consumption	g/m ²	-
Battery	-	Maintenance Free, gel battery
Run time	-	Up to 1.25 hours
Brush & Pad (diameter)	in (mm)	13.8 (350)
Brush motor	HP	1/3 HP
Drive type		semi-automatic
Forward movement speed	mph (km/h)	1.9 (3)
Maximum grade		2%
Vacuum motor	HP	1/3 HP
Solution tank capacity	Gal (l)	3 (11.4)
Recovery tank capacity	Gal (l)	3 (11.4)
Weight of empty machine (without battery)	lb (Kg)	85 (38.6)
Weight of empty machine (with battery)	lb (Kg)	135 (61.2)
Machine dimensions upright (Length / Height / Width)	in x in x in (mm/mm/mm)	35 x 17 x 44 (889 / 432 / 1118)
Machine dimensions stored (Length / Height / Width)	in x in x in (mm/mm/mm)	35 x 17 x 17 (889 / 432 / 432)

GENERAL SAFETY REGULATIONS

The regulations below must be carefully followed in order to avoid harm to the operator and damage to the machine.

- Read the labels on the machine carefully. Do not cover them for any reason and replace them immediately if they are damaged.
- The machine must be used exclusively by authorized and trained personnel.
- When operating the machine be careful of other people.
- The machine is not suitable for cleaning carpets.
- The power cable outlet must be plugged into a grounded power outlet.
- Avoid damaging the power cable by crushing, bending, cutting or stressing it.
- **WARNING:** do not let the power cable come into contact with the rotating brush.
- Whenever the power cable is damaged, immediately contact a BETCO service center.
- Do not mix different types of detergent as this may produce harmful gases.
- Do not set containers on the machine.
- Machine storage temperature is between -10°F and 130°F, never store outside under humid conditions.
- Operating conditions: room temperature between 33°F and 100°F with relative humidity between 30% to 95%.
- Do not expose the machine to rain.
- Never use the machine in an explosive environment.
- Do not use the machine as a means of transport.
- Never use acidic chemicals which could damage the machine.
- Avoid running the brushes with the machine stopped as this could damage the floor.
- Never vacuum up flammable liquids.
- Never use the machine to gather dangerous powders.
- Use a powder fire extinguisher in case of fire. Do not use water.
- Do not hit against shelving or scaffolding. The operator must always be equipped with the appropriate safety device (gloves, shoes, helmet, glasses, etc.)
- Do not use the machine on surfaces with an inclination greater than the one shown on the serial plate.
- The machine is designed to wash and dry floors simultaneously. Signal the presence of wet floors with suitable signs.
- If the machine does not work properly, perform routine maintenance. Otherwise, request the assistance of BETCO technical support.
- When replacing parts ask for ORIGINAL spare parts from your Authorized BETCO Dealer and/or Retailer.
- Always turn off the machine and unplug the power cord whenever maintenance is performed.
- Never remove guards that require tools to remove.
- **Never wash the machine with direct or pressurized jets of water or with corrosive substances.**
- Have your BETCO service center check the machine once a year.
- To prevent the formation of scale in the solution tank filter, do not store the machine with detergent in the tanks.
- Before using the machine make sure that all doors and covers are positioned as shown in this operating and maintenance manual.
- When your BETCO machine is ready to be retired, the machine must be disposed of properly. It contains oils and electronic components. The machine itself was built using totally recyclable materials.
- Use only brushes furnished with the machine or those specified in the user's manual. Use of other brushes can compromise safety.
- This machine must be operated by trained professionals.

MACHINE PREPARATION

1. HANDLING THE PACKED MACHINE

No more than two boxes can be stacked.

Total weight is 150 lbs. per box.

Overall dimensions are:

- A: 19.7 in (500 mm)
- B: 19.7 in (500 mm)
- C: 45.3 in (1150 mm)

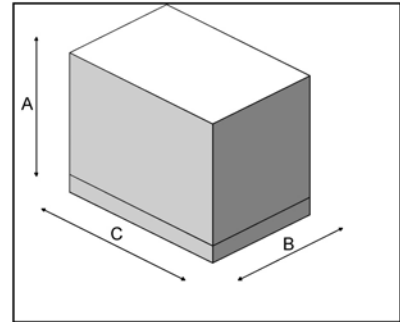

2. HOW TO UNPACK THE MACHINE

1. Open the box on the end indicated.
2. Remove the machine from box.
3. Remove the recovery tank.
4. Remove the pad driver.

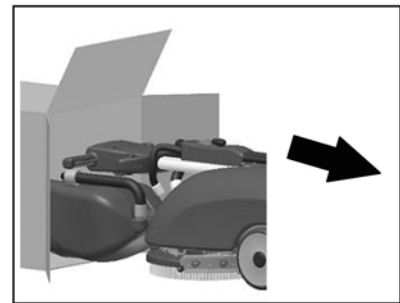

3. HANDLING AND TRANSPORTATION OF THE UNPACKED MACHINE

Genie™ B is a machine that can be transported with little effort. Be sure that squeegee assembly is in the UP position before transport.

Lift the front end of the machine, using the machine handle as a lever. The rear wheels allow it to be transported and can be loaded on a truck with the use of an approved ramp.

Genie™ B is easy to transport. By first removing the recovery tank, the handle can be folded down to minimize its size.

MACHINE PREPARATION

4. INSTALLING AND CONNECTING THE BATTERIES

The machine is supplied with an on-board battery charger and a sealed maintenance free battery. If a battery is used other than the one supplied with the machine, use only a 12 volt AGM or gel battery. The battery must be housed in the special compartment beneath the solution tank. To insert the batteries:

1. Disconnect the quick connector (1) at the front of the solution tank.
2. Remove the solution tank and place it on the ground.
3. Open the two rear latches (2) that hold down the battery compartment lid.
4. Lower the handlebar forward to open the battery compartment.
5. Position the battery inside the compartment with the terminals positioned toward the rear of the machine.
6. Connect Betco factory cables to the battery.



WARNING: It is advised to only use sealed batteries to avoid leaking battery acid.



WARNING: Only use battery cables that are made by a qualified technician.



WARNING: Always wear protective gloves to avoid the risk of serious injury.



WARNING: Only lift and move batteries with lifting means suitable for the specific weight and size.

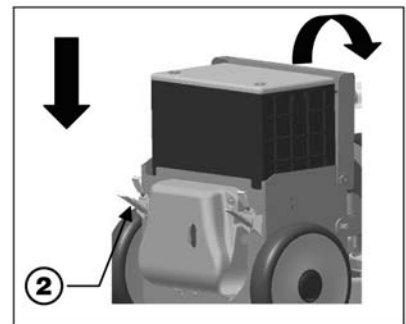
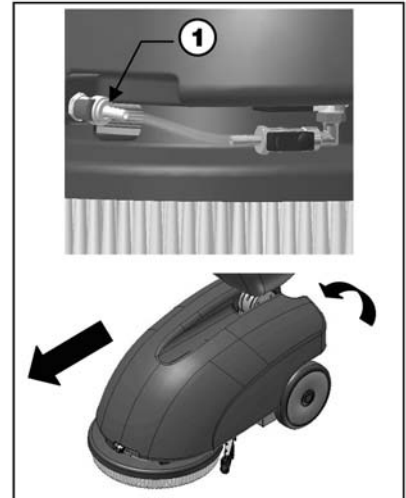

5. CONNECTING THE BATTERIES

1. Connect the batteries to the machine using the Anderson plug.
2. Reassemble all of the components.



WARNING: This process must be carried out by qualified personnel. Incorrect or improper connection of the battery cable can cause harm to people and objects.

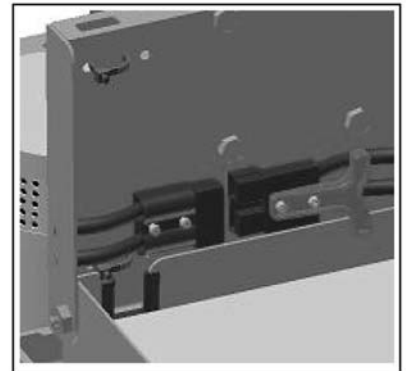

MACHINE PREPARATION

6. BATTERY MAINTENANCE AND DISPOSAL

For maintenance and recharging, follow the instructions provided by the battery manufacturer or only use factory supplied electrical components. There are many different kinds of chargers according to the type and capacity of the battery.

When the battery reaches the end of its useful life, it must be disconnected by trained personnel and removed from the battery compartment. Batteries must be recycled by a certified battery disposal facility.



WARNING: Always wear protective gloves to avoid the risk of serious injury.



WARNING: Only lift and move batteries with lifting means suitable for the specific weight and size.

7. CHARGING THE BATTERY (WITH BUILT IN ON-BOARD CHARGER)

Perform a battery charging cycle before using the machine.

To recharge the battery:

1. Make sure the recovery and solution tanks are empty.
2. Move the machine to a 110 volt electrical outlet.
3. Remove the rubber battery charger socket protection on the back of the machine.
4. Plug the power cable (provided with machine) into the battery charger.
5. Plug the power cable into the electrical outlet.

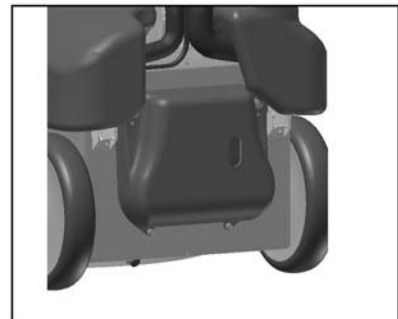

ATTENTION: If one of the three LED's begin flashing on the battery charger, refer to the battery charger manual supplied with the machine.



WARNING: It is important to avoid complete discharge of the batteries during use. Plan to recharge the batteries within a few minutes of the battery indicator turning the machine off.



WARNING: Never leave the batteries completely discharged, even if the machine is not being used.



WARNING: Do not use an open flame or spark near batteries.

MACHINE PREPARATION

8. BATTERY DISCHARGE INDICATOR

The battery indicator is digital with 4 fixed positions and a flashing signal. The numbers that appear on the display represent the approximate charge level.

4 = Maximum Charge

3 = 3/4 Charge

2 = 1/2 Charge

1 = 1/4 Charge

0 = Discharged Batteries (Flashing)



WARNING: A few seconds after the appearance of the flashing "0", the brush motor will automatically turn off. With the remaining charge, it is possible to continue using the vacuum motor to finish drying the surface before recharging.



9. INSTRUMENT PANEL COMPONENTS

The instrument panel components are identified as follows:

1. Main Power / Brush Motor Switch
2. Vacuum Motor Switch
3. Solution Valve Switch
4. Digital Battery Discharge Indicator

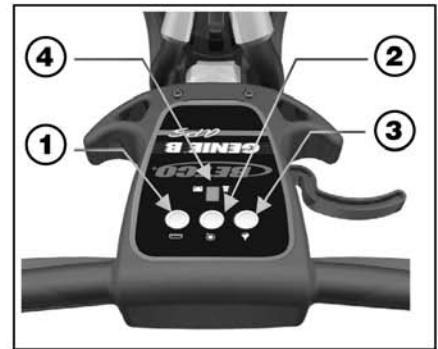

10. POSITIONING THE HANDLEBARS

For packaging purposes, the handlebars are positioned in the down location and must be put into working position.

1. Squeeze the lever on the right side of the machine to release the handle lock.
2. Lift the handle upwards while maintaining pressure on the lever.
3. Attach the recovery tank to the handle tube using the two hooks on the tank.
4. Attach the vacuum hoses to the lid on the recovery tank.



MACHINE PREPARATION

11. SOLUTION TANK

The recovery tank must be completely emptied each time the solution tank is filled.

Ensure the cap is correctly threaded into the solution tank (A).

Ensure that the quick connect fitting is properly connected at the front of the machine (B).

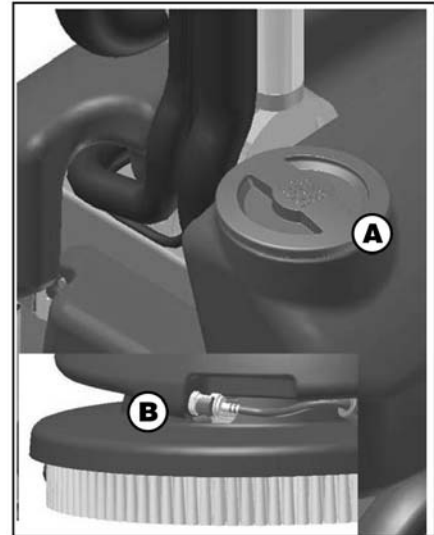

12. SOLUTION TANK FILLING

Fill the solution tank with clean water at a temperature that does not exceed 120°F (50°C). Add liquid detergent at the concentration and according to the procedures recommended by the chemical manufacturer. To prevent excess foam, use a defoaming chemical in the recovery tank. If foam passes through the vacuum motor, damage will occur and will not be covered under warranty.



WARNING: Always use low-foam detergent. Add defoaming chemical to the recovery tank before starting work to prevent foam from being generated.

WARNING: Never use acids.



WARNING: Always wear protective gloves to avoid the risk of serious injury.

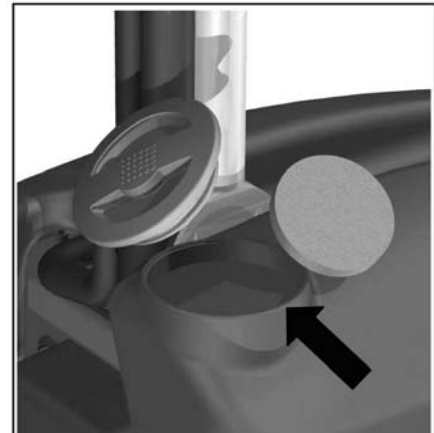

MACHINE PREPARATION

13. RECOVERY TANK

Make sure the recovery tank is empty, otherwise, empty it completely. Check that it is properly secured to the handle tube and that the hoses are correctly inserted in the tank elbows. Check the cap to ensure it is properly seated.



14. ASSEMBLING THE BRUSH

To install the brush - (Be sure squeegee is in the 'up' position)

1. Place the brush in front of the machine on the floor.
2. Raise the front of the machine using the handlebar as a lever.
3. Place the front of the machine over the brush, centering the hub into the clutch plate on the brush.
4. Press the main switch button to power on the machine.
5. Pull the operation lever on the handle to engage the brush to the brush hub.



OPERATION

1. MACHINE OPERATION

Before installing the tanks, it is necessary to carry out the following operations:

1. Open the two rear latches to the battery compartment and connect the battery.
2. Close the battery compartment and reconnect the latches.
3. Make sure that the recovery tank is empty.
4. Attach the recovery tank to the handlebar tube and connect the two vacuum hoses to the lid.
5. Place the solution tank over the base of the machine and connect the quick connector at the front of the machine.
6. Fill the solution tank as previously described.
7. Lower the squeegee assembly to the floor using the squeegee lift lever on the rear of the handle tube.

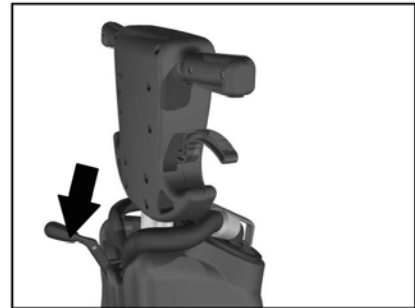
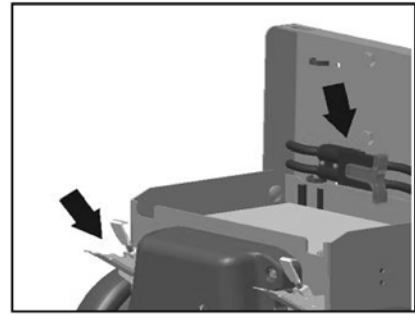

8. Press the main switch (1) and check that the green indicator light comes on.
9. Turn on the vacuum switch (2) and the solution control switch (3).
10. Pull the operation lever (4) to activate the brush and apply solution to the floor. The machine is now operating.



2. OVERFLOW DEVICE

The machine has a float in the filter basket that stops vacuum airflow when the recovery tank is full. When this happens the recovery tank must be emptied.



WARNING: Always wear gloves when doing this operation to protect yourself from contact with hazardous chemicals.



3. FORWARD MOVEMENTS

Forward movement of the machine is assisted by the brush.



WARNING: Always make sure the squeegee is lifted when moving backwards, even for short distances.

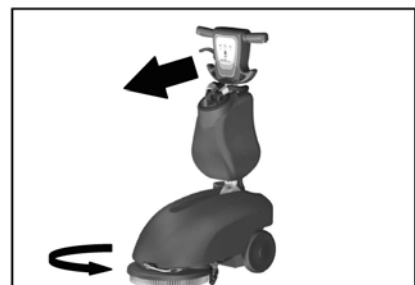

TURNING OFF THE MACHINE

13. RECOVERY TANK

To properly turn off the machine after use or before performing any maintenance:

1. Turn off the solution control switch (3).
 2. Turn off the vacuum switch (2).
 3. Turn off the main switch (1).
-
4. Raise the squeegee lift lever on the back side of the handle tube.
-
5. Transport the machine to the location provided to drain water.
 6. Disconnect the vacuum hoses and remove the recovery tank from the machine.
 7. Remove the recovery tank cap and tilt the tank to empty the waste water.
 8. Disconnect the quick connection at the front of the machine and remove the solution tank.
 9. Remove the cap from the solution tank and tilt the tank to dump any remaining solution.
 10. Remove the brush and rinse it with clean water.



WARNING: Always wear gloves when doing this operation to protect yourself from contact with hazardous chemicals.



WARNING: Never tilt the machine backwards and rest on the handle if there is water in the recovery tank. This may spill water into the electrical panel and cause permanent damage to the machine.

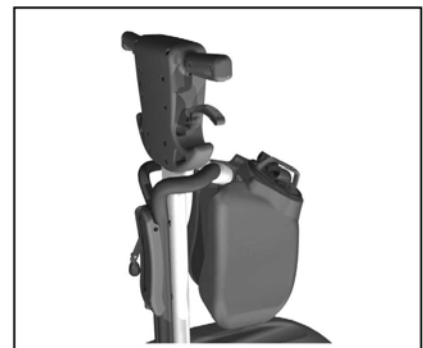
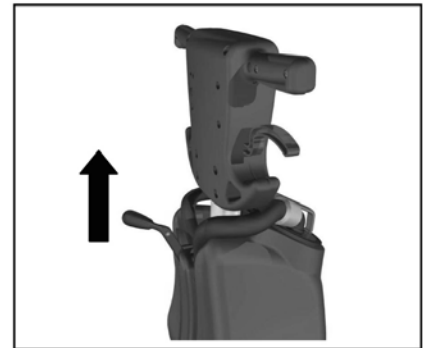

DAILY MAINTENANCE

1. CLEANING THE RECOVERY TANK

1. Disconnect the vacuum hoses from the recovery tank lid.
2. Detach the recovery tank from the handle tube.
3. Remove the lid and empty the tank.
4. Rinse the float ball filter cage with clean water.
5. Rinse the inside of the tank with clean water.
6. Reassemble the recovery tank.



WARNING: Always wear gloves to protect yourself from contact with hazardous chemicals.



2. CLEANING THE SQUEEGEE

Verify that the squeegee blades are clean and free from cuts. This ensures optimum drying.

To clean the squeegee:

- A. Raise the front of the machine.
- B. Carefully clean the inside of the squeegee shoe.
- C. Carefully clean the squeegee blades.



WARNING: Always wear gloves to protect yourself from contact with hazardous chemicals.

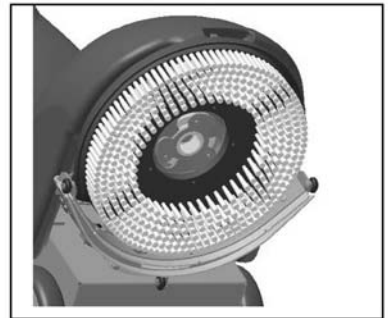

DAILY MAINTENANCE

3. REPLACING THE SQUEEGEE BLADES

Examine the condition of the squeegee blades. Replace as necessary. To replace the blades:

- A. Lift the squeegee.
- B. Remove the two knobs.
- C. Detach the squeegee from the squeegee yoke.
- D. Remove the hose from the squeegee hose adaptor.



WARNING: Before carrying out any type of maintenance, disconnect the machine's battery connector.



WARNING: Always wear gloves to protect yourself from contact with hazardous chemicals.

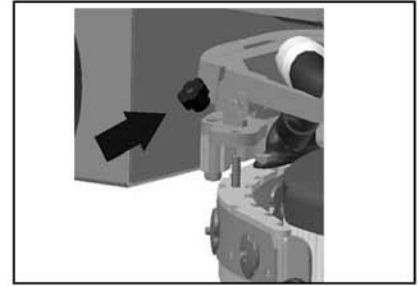

- E. Unscrew the squeegee knobs that hold the band clamps on squeegee shoe.
- F. Remove the band clamps and squeegee blades.
- G. Replace the squeegee blades and band clamps.
- H. Reinstall everything by performing this procedures in reverse.
- I. Inspect the squeegee guide wheels to make sure they spin freely and have no damage. Replace if necessary.

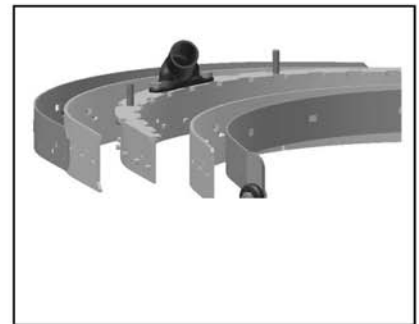
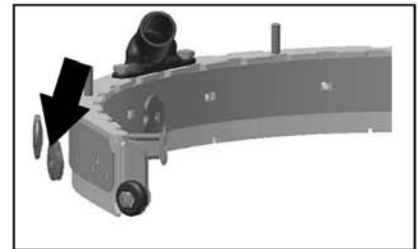

4. BRUSH DISASSEMBLY

- A. Lock the squeegee in 'up' position.
- B. Lift the front of the machine by pressing down on the handle until the brush is 2" - 4" off the floor.
- C. When the brush is lifted jog the brush motor. The brush releases automatically and falls onto the floor.



WARNING: Always wear gloves to protect yourself from contact with hazardous chemicals.



SCHEDULED MAINTENANCE

1. CLEANING THE SQUEEGEE HOSE

Check the squeegee hose for blockage if the suction is insufficient and at periodic intervals. To clean the hose:

- A. Remove the hose end from the squeegee hose adapter.
- B. Remove the other end of the hose from the recovery tank.
- C. Wash the inside of the hose with clear water, spraying from the end that connects to the tank.
- D. Reinstall the hose.



WARNING: Do not wash the hose that goes from the vacuum unit to the recovery tank. This will damage the vacuum motor!

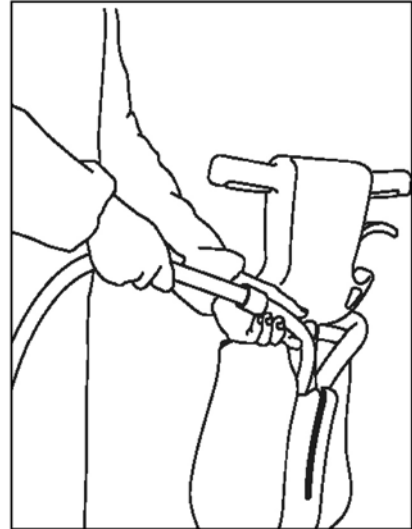

2. CLEANING THE SOLUTION TANK AND FILTER

1. Disconnect the quick connection at the front of the machine (1).
2. Remove the solution tank from the machine.
3. Unscrew the solution cap (2).
4. Remove the screen filter (3) and rinse with clean water.
5. Rinse the inside of the tank with clean water.
6. Install the tank back on the machine.



WARNING: Always wear gloves to protect yourself from contact with hazardous chemicals.

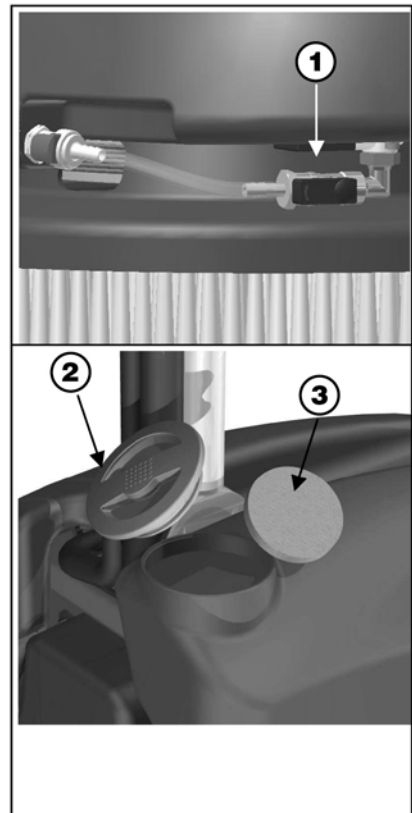

TROUBLESHOOTING GUIDE

1. ELECTRICAL SYSTEM SAFETY

The machine is equipped with self-resetting thermal safety fuses located in the electric box beneath the solution tank. These fuses interrupt the power supply to the brush and suction motor when the machine exceeds the predetermined current limit. To restore power to the motor, switch off the machine and wait for the fuses to cool down. If the switch interrupts power supply again, contact Betco technical service assistance.

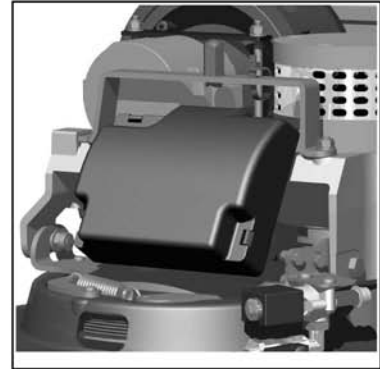

2. INSUFFICIENT WATER ON THE FLOOR

- A. Verify that the solution tank is clean.
- B. Verify that the solenoid valve switch is turned on.
- C. Verify the quick disconnect is properly connected.
- D. Verify the adjustment of the ball valve that supplies water.
- E. Verify the vent pin on the solution tank cap is lowered.

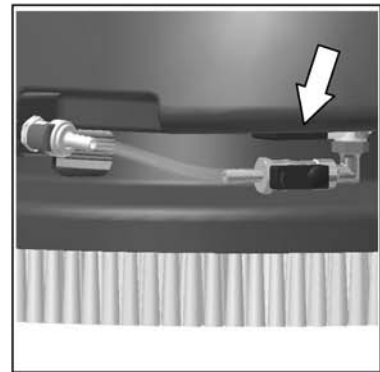

3. THE MACHINE DOES NOT CLEAN WELL

- A. Check the condition of the brushes or pad. Replace them as required.
Brushes must be replaced when the tufts are roughly 5/8" (15 mm) long.

4. THE SQUEEGEE DOES NOT DRY THE FLOOR

- A. Verify that the squeegee blades are clean.
- B. Verify that the vacuum hoses are properly installed and seated on the squeegee.
- C. Verify the vacuum hose nozzle is clean.
- D. Replace worn squeegee blades.
- E. Check squeegee guide wheels for wear or damage.



5. EXCESSIVE FOAM PRODUCTION

Verify that low-foam detergent is being used. Add defoaming chemical to the recovery tank.

More foam is generated when the floors are not very dirty. Dilute the detergent more when cleaning floors that are not very dirty.

BRUSH SELECTION AND USE

POLYPROPYLENE BRUSHES (PPL)

These are used on all types of floors and offer good wear resistance.

PAD DRIVERS

Pad driver and an floor pad is recommended when cleaning smooth floors.

There are two types of pad drivers:

1. The traditional pad driver is fitted with a series of anchor points that allow the abrasive floor pad to be held while working.
2. The CENTER LOCK type pad driver not only has anchor points, but also a snap-type central locking system made of plastic that allows the abrasive floor pad to be centered and held with reduced risk of it becoming detached.

BRUSH DECK PARTS DIAGRAM

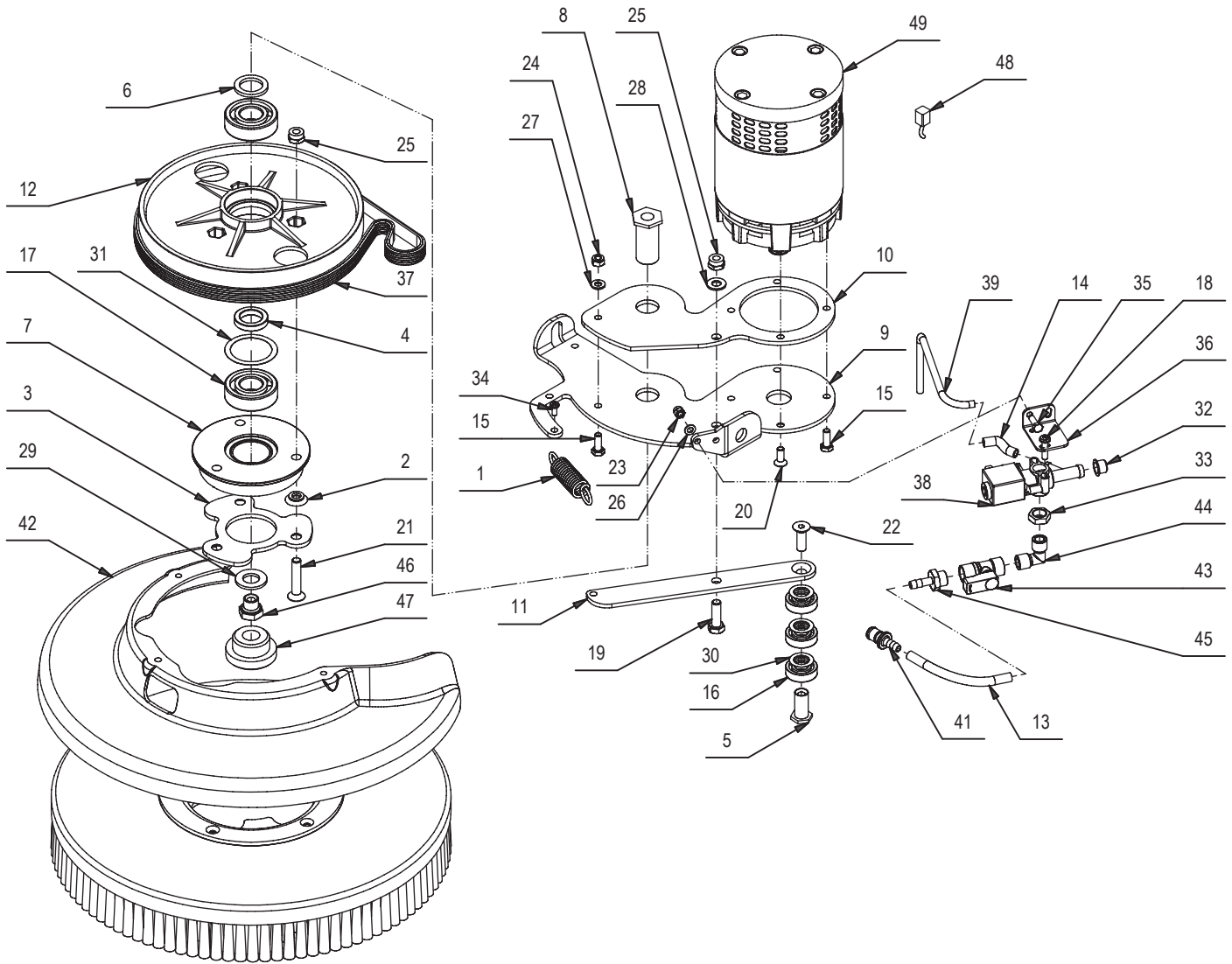

BRUSH DECK PARTS LISTING

Item#	Part #	Description	Qty.
1	E81530	Spring, 17, 5x2, 5x69 mm	1
2	E82845	Spacer	3
3	E82844	Clutch Plate	1
4	E20503	Spacer	1
5	E88228	Bushing	1
6	E20019	Spacer	1
7	E86253	Clutch Flange	1
8	E20026	Bearing Shaft	1
9	E20403	Bracket	1
10	E20047	Motor Mount Plate	1
11	E88366	Tensioner Arm	1
12	E20553	Clutch Pulley	1
13	E82710	Hose, 8 OD x 5 ID x L 105	1
14	E81752	Tubing 5 OD x 30 L	1
15	E83547	M6x16 Bolt, Zinc Hex Head	4
16	E86667	Bearing, 6001 2RS	3
17	E81657	Bearing, 6204 2RS	2
18	E82288	Screw, Pan Hd Phil Self Tap	2
19	E83833	Hex Bolt M8x25 Zinc	1
20	E88042	Flat Hd Soc Machine Screw M6x16 Zinc	1
21	E81871	Flat Hd Soc Machine Screw M8x40 Zinc	3
22	E20291	Flat Hd Soc Machine Screw M8x25 Zinc	1
23	E82256	Nyloc Hex Nut, M5x7 Zinc	2
24	E83550	Nyloc Hex Nut, M6 Zinc	1

Item#	Part #	Description	Qty.
25	E81709	Nyloc Hex Nut, M8 Zinc	4
26	E83879	Flat Washer M5x11x1 Zinc	2
27	E82761	Washer 6x12x1.6	1
28	E81874	Flat Washer M8x17x1.6 Zinc	1
29	E20395	Flat Washer M14 SS	1
30	E83903	Shim Washer M14x22x0.3	3
31	E87290	Shim M37x47x0.3	1
32	E81719	Cap	1
33	E81967	Jam Nut, 1/4" NPT Brass	1
34	E81998	Pan Hd Phil Machine Screw M4x10 SS	3
35	E86250	Hex Bolt M5x14 Zinc	2
36	E81727	Bracket	1
37	E81541	Brush Drive Belt	1
38	E82467	Solenoid Valve 12VDC	1
39	E86167	Pipe, 1/4" x 8" Copper	1
41	E82711	Quick Disconnect, Male 1/4"	1
42	E81543	Guard, Vispa	1
43	E81550	Ball Valve, 1/4" NPT Double Female	1
44	E81551	Elbow, 90 degree 1/4" Brass NPT	1
45	E81552	Fitting, Brass, 1/4" x 7mm"	1
46	E20157	Hex Lug	1
47	E86156	Bushing	1
48	E81553	Carbon Brush	4
49	E81555	Brush Motor 12VDC 360W	1

SQUEEGEE SYSTEM PARTS DIAGRAM

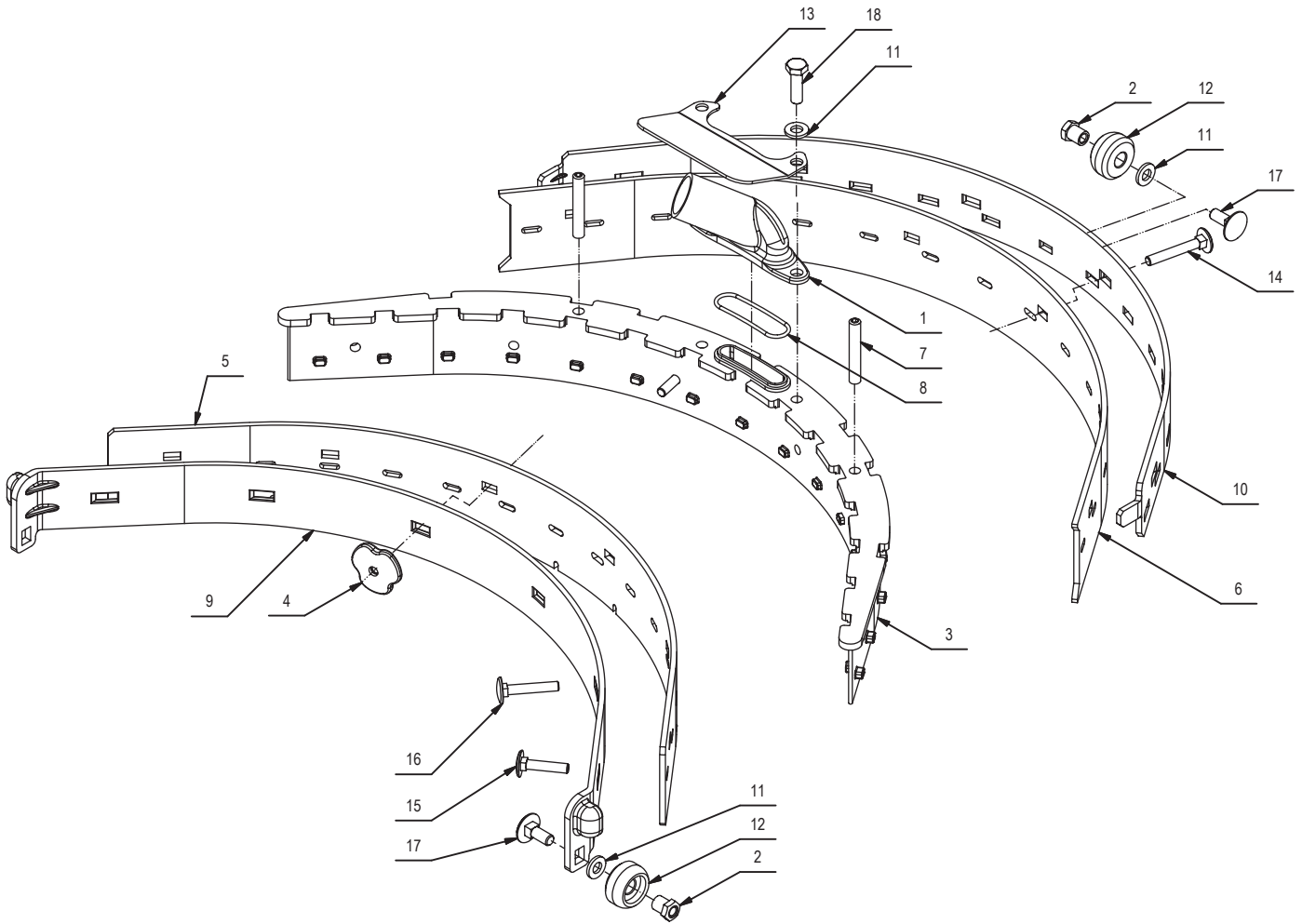

SQUEEGEE SYSTEM PARTS LISTING

Item#	Part #	Description	Qty.
1	E81815	Squeegee Vacuum Adapter	1
2	E81897	Bushing	1
3	E85792	Squeegee Shoe	1
4	E81753	Knob M5	1
5	E83870	Squeegee Blade, Front, Shore 33	1
6	E83869	Squeegee Blade, Rear, Shore 33	1
7	E82707	Set Screw Hex Soc Flat End M6x40 SS	1
8	E81755	O-Ring	1
9	E81909	Front Squeegee Band Clamp	1
10	E82731	Rear Squeegee Blade Band Clamp	1

Item#	Part #	Description	Qty.
11	E81934	Flat Washer M6x12x1.6 SS	1
12	E81531	Squeegee Support Wheel 24 OD x 12.7 W	4
13	E20701	Squeegee Hose Guard	4
14	E20616	Carriage Bolt M5 x 35 SS	2
15	E86264	Carriage Bolt M5x25 SS	1
16	E81941	Carriage Bolt M5x30 SS	1
17	E81896	Carriage Bolt M6x16 SS	1
18	E83914	Hex Bolt M6x20 SS	1
*	E81921	Complete Squeegee Assembly	1

SQUEEGEE YOKE PARTS DIAGRAM

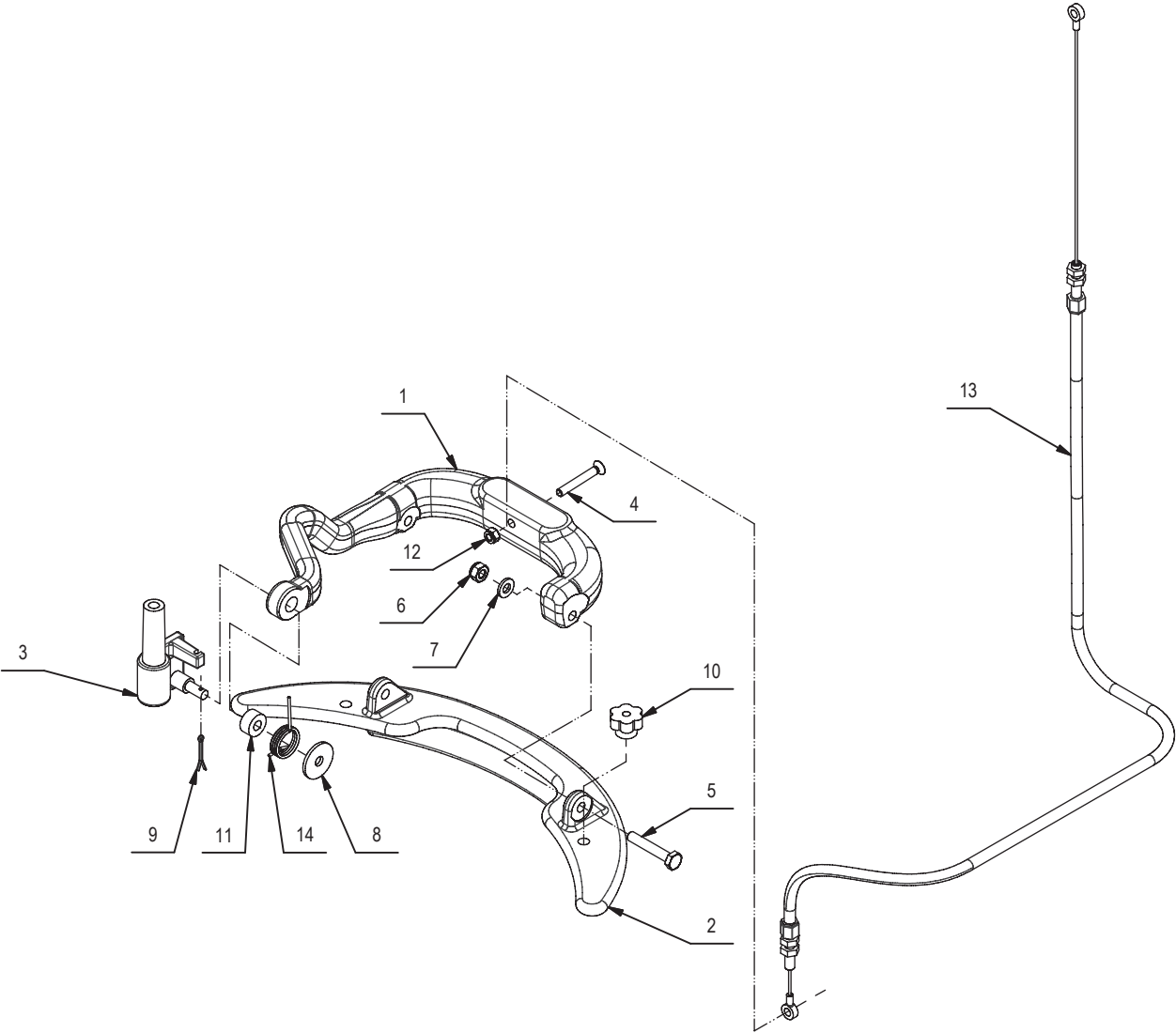

SQUEEGEE YOKE PARTS LISTING

Item#	Part #	Description	Qty.
1	E87971	Squeegee Yoke Arm	1
2	E86153	Squeegee Yoke	1
3	E82839	Squeegee Yoke Pivot	1
4	E86263	Oval Hd Phil Machine Screw M5x35 SS	1
5	E83834	Hex Bolt M6x35 Zinc	2
6	E83550	Nyloc Hex Nut, M6 Zinc	2
7	E82761	Washer 6x12x1.6	2

Item#	Part #	Description	Qty.
8	E83278	Flat Washer M6.5x24x2 Zinc	1
9	E83710	Cotter Pin D2x20 Zinc	1
10	E83810	Knob	2
11	E86152	Spacer	1
12	E20382	Nyloc Hex Nut, M5 x 5 Zinc	1
13	E82419	Squeegee Lift Cable	1
14	E81545	Spring	1

MAIN FRAME PARTS DIAGRAM

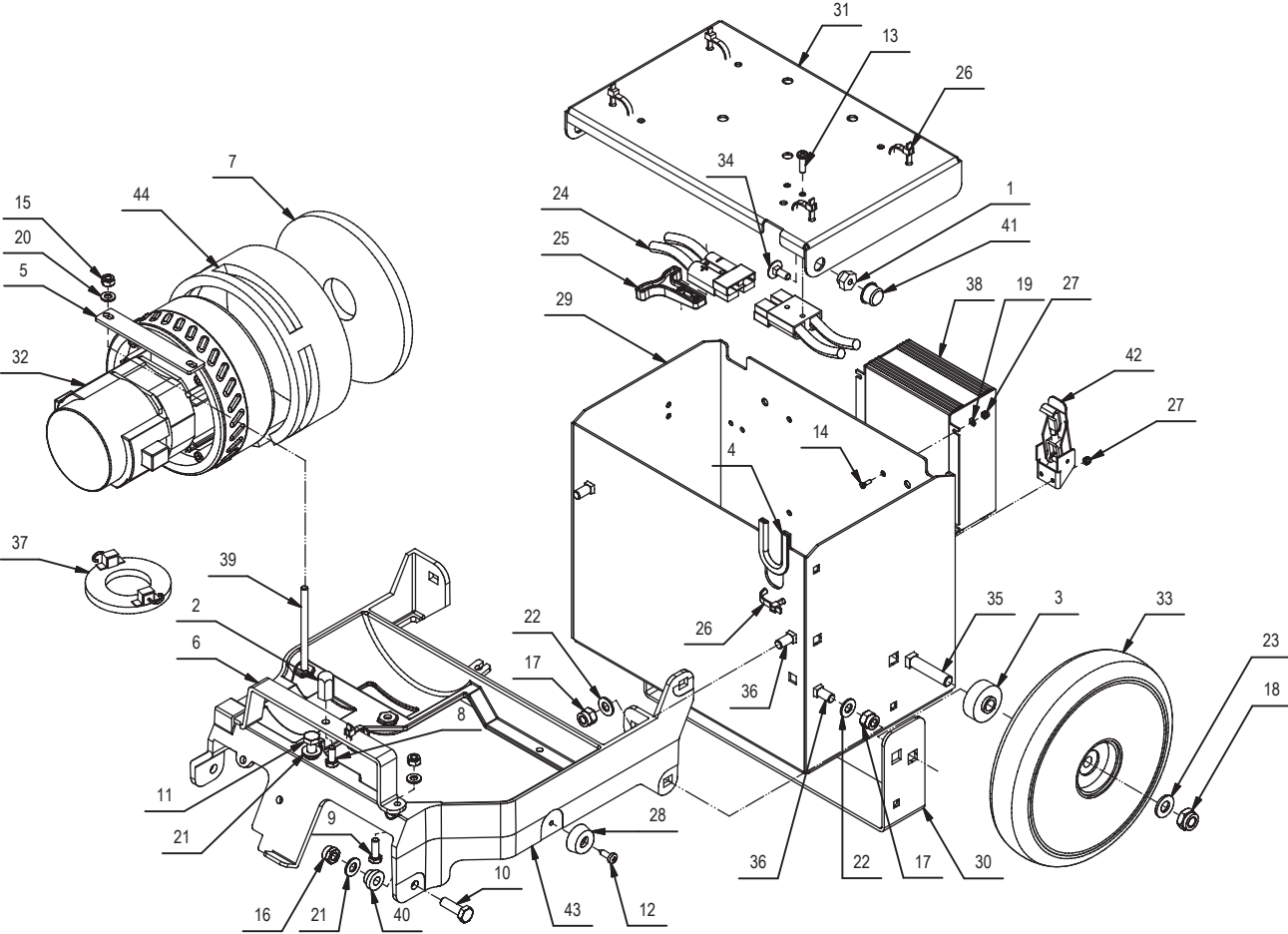

MAIN FRAME PARTS LISTING

Item#	Part #	Description	Qty.
1	E20272	Bushing	2
2	E20020	Hex Lug	1
3	E86269	Bushing	2
4	E20050	Protective Trim Edging	1
5	E20587	Clamp Plate	1
6	E20053	Bracket	1
7	E83944	Sound Deadening Foam	1
8	E82456	Hex Bolt M6x14 Zinc	1
9	E20088	Hex Bolt M6x18 Zinc	1
10	E83833	Hex Bolt M8x25 Zinc	2
11	E20098	Hex Bolt M8x18 Zinc	1
12	E20108	Screw, Pan Hd Phil Self Tap M4.8x16 SS	2
13	ET1002	Screw, Pan Hd Phil Self Tap	2
14	E20098	Hex Bolt M8x18 Zinc	8
15	E83550	Nyloc Hex Nut, M6 Zinc	3
16	E81709	Nyloc Hex Nut, M8 Zinc	2
17	E81342	Nyloc Hex Jam Nut, M8 SS	4
18	ET1001	Nyloc Hex Nut, M10 SS	2
19	E81979	Flat Washer M3x7x0.5 SS	4
20	E82761	Washer 6x12x1.6	3
21	E81874	Flat Washer M8x17x1.6 Zinc	3
22	E88238	Flat Washer, M8x17x1.6 SS	4

Item#	Part #	Description	Qty.
23	E86255	Flat Washer M10x21x2 SS	2
24	E88349	SB50 Blue Electrical Connector	2
25	E89141	Charger Plug Tee Handle	1
26	E81565	Clamp, 4.8x200 Black	6
27	E20435	Nyloc Hex Nut, M3 SS	8
28	E20568	Rubber Bumper	2
29	E86215	Battery Box	1
30	E86270	Bracket	1
31	E20258	Battery Box Lid	1
32	E81538	Vacuum Motor 12VDC 250W	1
33	E81539	Transport Wheel 200 OD x 42 W	2
34	E81896	Carriage Bolt M6x16 SS	2
35	E85755	Carriage Bolt M10x50 SS	2
36	E20152	Carriage Bolt M8x20 SS	4
37	E81540	Carbon Brush	1
38	E81544	Charger 12VDC 6AMP 120VAC ONB AGM GEL BSB50	1
39	E20461	Hex Bolt M6x90 Zinc	2
40	E20383	Bushing	2
41	E20586	Cap	2
42	E86199	Latch	2
43	E87024	Main Frame Weldment	1
44	E82840	Sound Deadening Foam	1

SOLUTION AND RECOVERY TANKS PARTS DIAGRAM

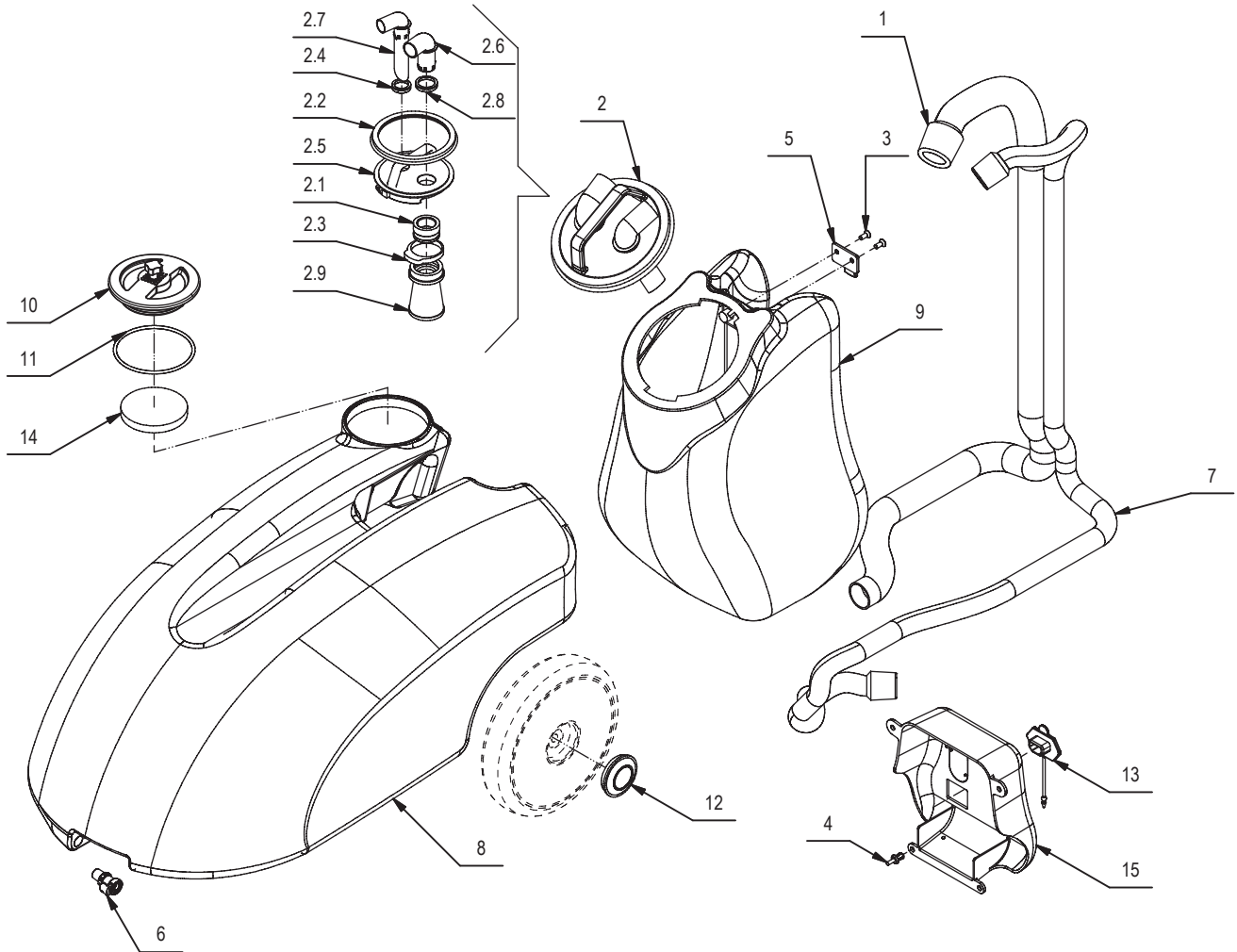

SOLUTION AND RECOVERY TANKS PARTS LISTING

Item#	Part #	Description	Qty.
1	E81532	Hose, Vacuum 29 D x 1250 L	1
2	E81534	Recovery Tank Cap ASM	1
2.1	E82853	Filter Flange	1
2.2	E82381	Gasket Ring	1
2.3	E81710	Hose Clamp	1
2.4	E81944	Grommet	1
2.5	E86217	Recovery Tank Cap	1
2.6	E81849	Vacuum Elbow Fitting	1
2.7	E81943	Vacuum Elbow Fitting Long	1
2.8	E86193	Grommet	1
2.9	E82360	Air Filter/Shutoff	1
3	E81963	Flat Hd Soc Machine Screw M5x12 SS	4

Item#	Part #	Description	Qty.
4	E83476	Rivet, M6.4x10 Nylon	4
5	E81968	Latch	2
6	E82712	Quick Disconnect, Female 1/4"	1
7	E81546	Hose, Vacuum 20 D x 1600 L	1
8	E81556	Solution Tank	1
9	E81972	Recovery Tank	1
10	E81548	Solution Tank Cap	1
11	E81549	O-Ring	1
12	E81971	Wheel Cap	2
13	E81969	Rubber Cap	1
14	E82398	Filter, Inlet	1
15	E85513	Battery Charger Cover	1

CONTROL HANDLE PARTS DIAGRAM

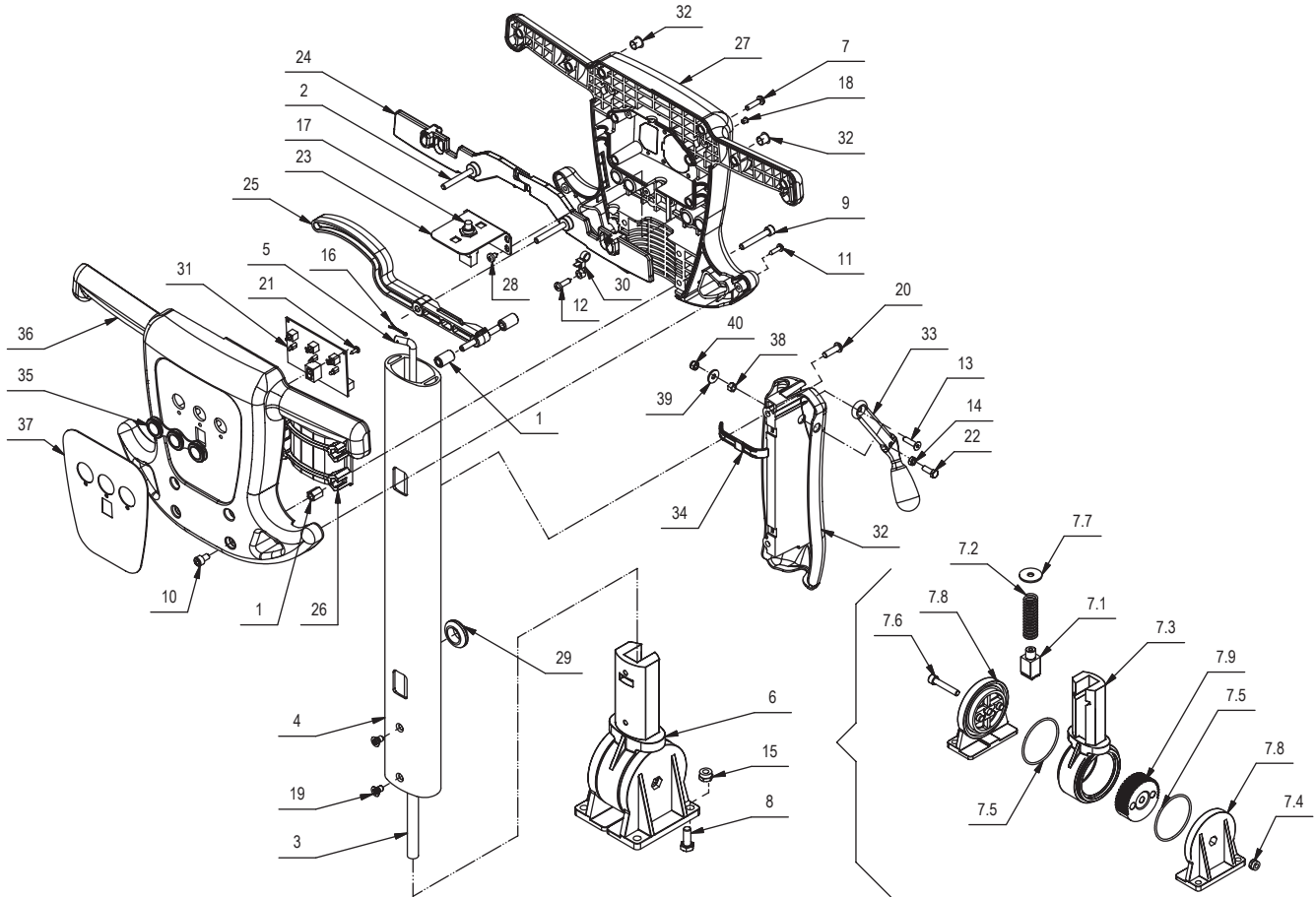

CONTROL HANDLE PARTS LISTING

Item#	Part #	Description	Qty.
1	E85770	High Hex Nut M6x13 Zinc	4
2	E81793	Spring Pin M6x12 Zinc	3
3	E20273	Connector Tube	1
4	E20620	Handle Tube	1
5	E82721	Tie Rod	1
6	E20593	Handle Pivot Base ASM	1
7.1	E88761	Pin	1
7.2	E20519	Spring	1
7.3	E88762	Handle Coupler	1
7.4	E81709	Nyloc Hex Nut, M8 Zinc	1
7.5	E20300	O-Ring	2
7.6	E20133	Soc Hd Cap Screw M8x45 Zinc	1
7.7	E81918	Flat Washer M9x32x2.5 Zinc	1
7.8	E88763	Geared Support	2
7.9	E88764	Pivot Gear	1
7	E82288	Screw, Pan Hd Phil Self Tap	10
8	E81917	Hex Bolt M8x20 Zinc	4
9	E20342	Soc Hd Cap Screw M6x40 Zinc	4
10	E82835	Soc Hd Cap Screw M6x10 Zinc	4
11	E82257	Screw M9 x 16	2
12	E20109	Screw, Pan Hd Phil Self Tap M4.8x19 Zinc	1
13	E88765	Screw, M5x20	1
14	E82317	Hex Jam Nut, M5X3.5 Zinc	1
15	E81709	Nyloc Hex Nut, M8 Zinc	4
16	E83710	Cotter Pin D2x20 Zinc	1

Item#	Part #	Description	Qty.
17	E82796	Switch, Momentary	1
18	E81791	Plug	1
19	E88173	Flat Hd Phil Machine Screw M6x10 Zinc	2
20	E20364	Button Hd Soc Machine Screw M6x20 Zinc	2
21	E81875	Screw, Pan Hd Phil Self Tap M2.9x9.5 Zinc	4
22	E86250	Hex Bolt M5x14 Zinc	1
23	E20567	Bracket	1
24	E81792	Switch Lever	2
25	E81766	Lever, Handle Adjustment	1
26	E81994	Support	1
27	E81744	Handle Bar Console Rear	1
28	E86150	Screw, Pan Hd Phil Self Tap M4.8x9.5 SS	4
29	E20302	Grommet	1
30	E20397	Wire Clamp	1
31	E81676	Control Switch Electrical Board	1
32	E81790	Cap	2
32	E88428	Plastic Cover	1
33	E20264	Squeegee Lift Lever	1
34	E20544	Plastic Mounting Clip	1
35	E86171	Panel, Rubber Push Button	1
36	E81781	Handle Bar Console Front	1
37	E20502	Console Decal	1
38	E86132	Spacer	1
39	E20121	Flat Washer M5x15x1.5 Zinc	1
40	E20256	Nyloc Hex Jam Nut, M5 Zinc	1

ELECTRIC SYSTEM PARTS DIAGRAM

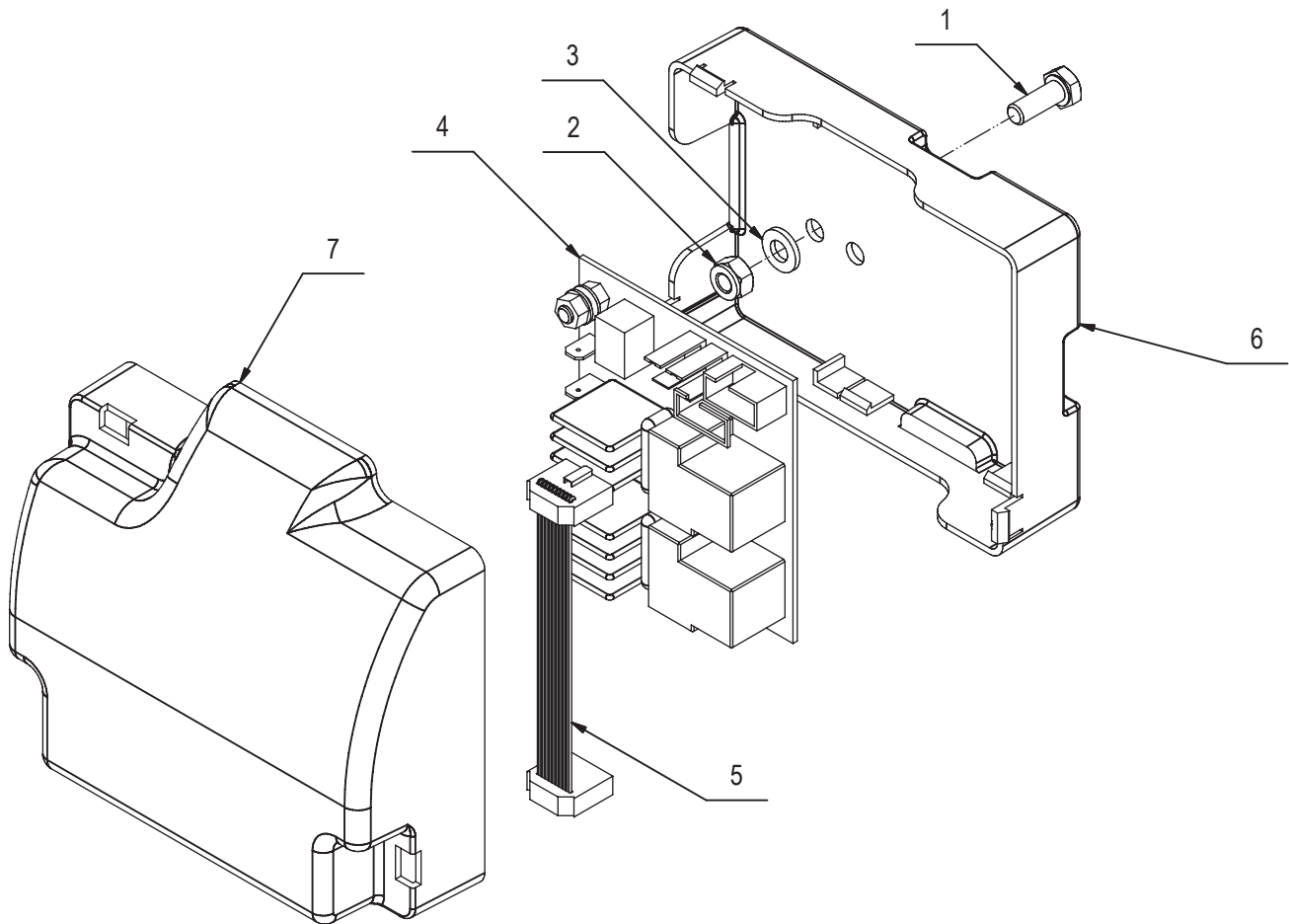

ELECTRIC SYSTEM PARTS LISTING

Item#	Part #	Description	Qty.
1	E83547	M6x16 Bolt, Zinc Hex Head	1
2	E83550	Nyloc Hex Nut, M6 Zinc	1
3	E82761	Washer 6x12x1.6	1
4	E81767	Relay Electrical Board	1

Item#	Part #	Description	Qty.
5	E81787	Ribbon Cable	1
6	E85788	Electrical Housing	1
7	E85771	Electrical Cover	1

BATTERY CHARGER DIAGRAM

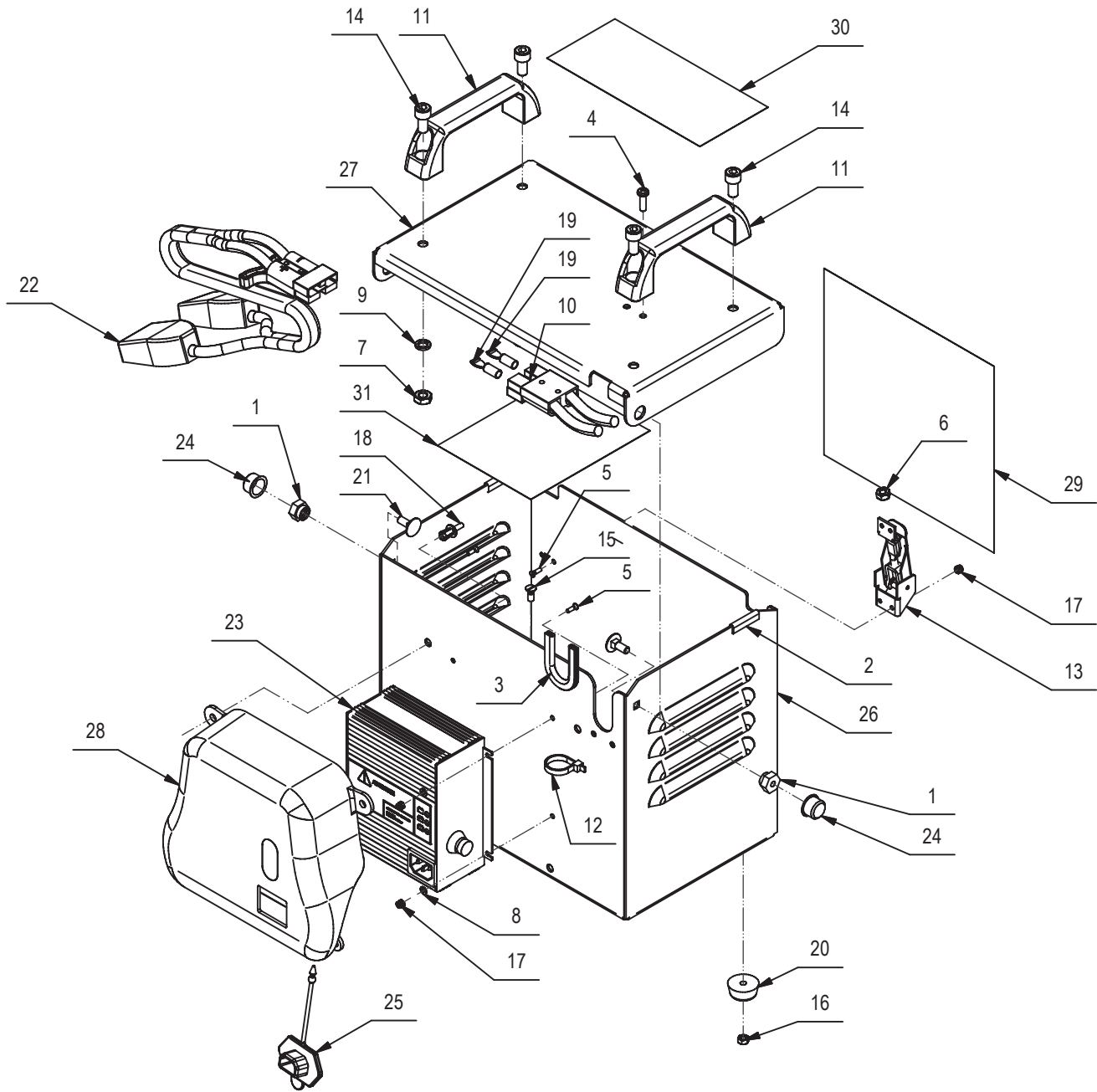

ELECTRICAL LISTING

Item#	Part #	Description	Qty.
1	E20272	Bushing	2
2	E20579	Protective Trim Edging	2
3	E20050	Protective Trim Edging	1
4	E20393	Screw, Pan Hd Phil Self Tap	2
5	E81672	Flat Hd SL Machine Screw M3x10 SS	8
6	E83852	Hex Nut, M6x5	2
7	E82808	Hex Jam Nut, M8X5 Zinc	4
8	E81979	Flat Washer M3x7x0.5 SS	4
9	E83704	Lock Washer M8x13x2.2 Zinc	4
10	E20347	SB50 Blue Electrical Connector	1
11	E88090	Handle Enjoy 365	2
12	E81565	Clamp, 4.8x200 Black	1
13	E82376	Latch, Catch & Clasp 2pc set	2
14	E20254	Soc Hd Cap Screw M8x16 Zinc	4

Item#	Part #	Description	Qty.
15	E20363	Flat Hd SL Machine Screw M5x12 SS	4
16	E20322	Hex Nut, M5 SS	4
17	E20435	Nyloc Hex Nut, M3 SS	8
18	E83476	Rivet, M6.4x10 Nylon	4
19	E81537	Contact, SB50	2
20	E20568	Rubber Bumper	4
21	E81896	Carriage Bolt M6x16 SS	2
22	E88340	Cable, Battery Vispa Genie After 209XXXXX	1
23	E81544	Charger 12VDC 6AMP 120VAC ONB AGM GEL BSB50	1
24	E20586	Cap	2
25	E81969	Rubber Cap	1
26	E20621	Battery Box	1
27	E20167	Battery Box Lid	1
28	E20415	Battery Charger Cover	1

ACCESSORIES DIAGRAM

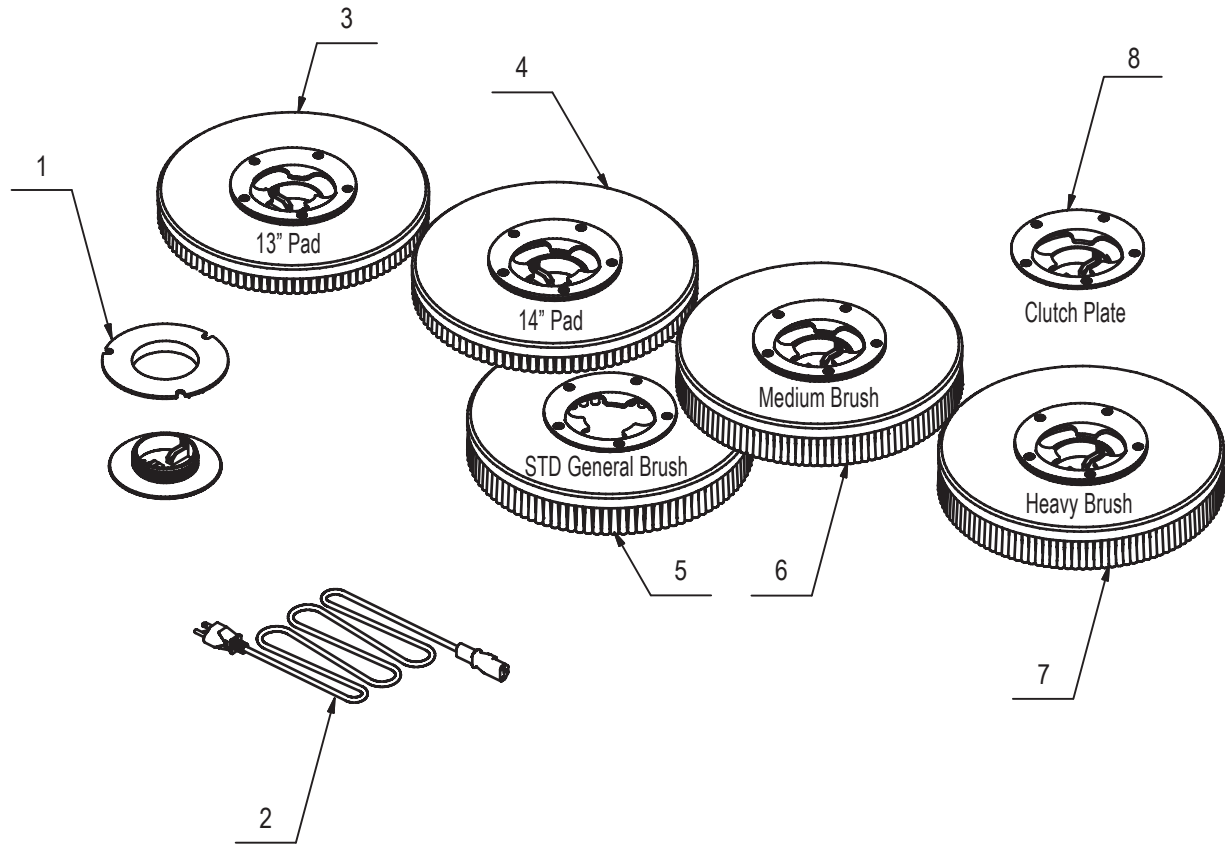

ACCESSORIES LISTING

Item#	Part #	Description	Qty.
1	E82367	Center Lock	1
2	E82438	Power Cord	1
3	E82408	Pad Driver	1
4	E88140	Pad Holder 14" STD	1

Item#	Part #	Description	Qty.
5	E83863	Brush, General Scrub 0.3 mm PPL	1
6	E82526	Brush, Medium Scrub 0.4 mm PPL	1
7	E81608	Brush, Heavy Scrub 0.6 mm PPL	1
8	E81711	Clutch Plate	1

BETCO US WARRANTY POLICY

10 year coverage

Subject to the conditions stated below, Betco warrants parts and labor on rotationally molded polyethylene tanks/housings and injection molded vacuum head assemblies to be free from defects in materials and workmanship for a period of ten years to the original purchaser.

3 Year Coverage

Subject to the conditions stated below, Betco warrants parts and labor on all other Betco components to be free from defects in materials and workmanship for a period of three years to the original purchaser.

1 Year Coverage

Subject to the conditions stated below, Betco offers a limited warranty on parts and labor on the following equipment: parts and accessories to be free from defects in materials and workmanship for a period of one year to the original purchaser.

- HF14 Upright Vacuum: #E88820-00
- Bac Pac Lite Vacuum: #85903-00
- FiberPRO® Floor Dryer: #85507-00
- WORKMAN™ Series Vacuums: #85024-00, #85025-00, #83012-00, #85027-00
- CV100T Vacuum: #85023-00
- All Tools and Accessories
- All Battery Chargers
- All Batteries are pro-rated for 1 year

Allowable Travel Time Warranty Reimbursement:

Eligible equipment: All battery and propane powered equipment products. Warranty period: 90 days from date of sale to the original purchaser. A maximum 60 mile round trip at 44 cents per mile will be allowed for warranty consideration.

Propane Machine Warranty:

Kawasaki engines are warranted by Kawasaki for a period of 2 years against manufacturer defects. All other components (except wear items)* are warranted by Betco for a period of 3 years.

***Wear Items exempt from Warranty consideration include but may not be limited to: power cords, transport wheels, vacuum bags, belts, squeegee blades, pad drivers, clutch plates, handle grips, filters, screens, throttle cables, brushes and carbon brushes.**

Subject to the conditions and exceptions stated in this warranty, Betco warrants the Betco products to be free from defects in material and workmanship, under normal use and service, for the periods listed under the warranty policy to the original purchaser. At any time during the warranty period, Betco will furnish replacement parts for the Betco parts to the original purchaser. Such parts will be furnished and charged including transportation costs, to the original owner through any Betco authorized Service Distributor. If the original part is returned within the warranty policy period from date of delivery for inspection by Betco and is found to be defective the owner will be credited for the cost of replacement parts plus shipping and handling. Replacement parts that have become defective through wear or abuse are not included in this warranty.

This warranty does not apply to damage or defect caused by accident, misuse, Negligence, fire, or to any Betco product which has been serviced or repaired by other than an authorized Betco Service Distributor or Betco factory personnel. This warranty is void if products are used for any purpose other than that which was intended. There are no other warranties expressed or implied. In no event shall Betco be liable for incidental or consequential damages or any damage to person or property. (Please note some states do not allow the exclusion or limitations for incidental and consequential damages).

