



# SpeedGleam®/Plus

36 Volt Dust Control Burnisher

**Model No.:**

- 608525 – SpeedGleam
- 608526 – SpeedGleam Pac.
- 609251 – SpeedGleam Pac. Can.
- 608344 – SpeedGleam Plus
- 608345 – SpeedGleam Plus Pac.
- 609252 – SpeedGleam Plus Pac. Can.

**Operator and Parts Manual**

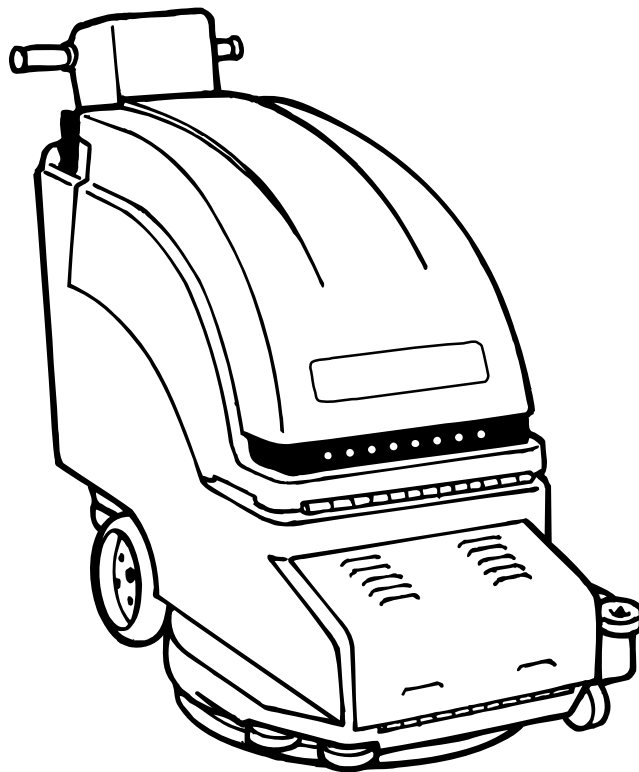

**NOBLES**  
12875 RANSOM STREET  
HOLLAND MI 49424 U.S.A.

**CUSTOMER SERVICE: 1-800-365-6625**  
**FAX: 1-800-678-4240**

**608382**  
**Rev. 01 (12-00)**

# OPERATION

---

This manual is furnished with each new model. It provides necessary operation, machine maintenance instructions and parts list.

**Read this manual completely and understand the machine before operating or servicing it.**

When ordering replacement parts use the Standard Parts List in this manual. Before ordering parts or supplies, be sure to have your machine model number and serial number handy. Parts and supplies may be ordered by phone or mail from any authorized parts and service center, distributor or from any of the manufacturer's subsidiaries.

This machine will provide excellent service. However, the best results will be obtained at minimum costs if:

- The machine is operated with reasonable care.
- The machine is maintained regularly - per the maintenance instructions provided.
- The machine is maintained with manufacturer supplied or equivalent parts.

---

## MACHINE DATA

---

Please fill out at time of installation for future reference.

Model No.- \_\_\_\_\_

Install. Date - \_\_\_\_\_

Serial No.- \_\_\_\_\_

© 2000 Tennant Company

Printed in U.S.A

**TABLE OF CONTENTS**

<b>SAFETY PRECAUTIONS</b> .....	<b>4</b>	<b>TROUBLE SHOOTING</b> .....	<b>14</b>
<b>MACHINE COMPONENTS</b> .....	<b>5</b>	<b>SPECIFICATIONS</b> .....	<b>15</b>
<b>CONTROL PANEL SYMBOLS</b> .....	<b>5</b>	<b>ELECTRICAL DIAGRAMS</b> .....	<b>16</b>
<b>MACHINE INSTALLATION</b> .....	<b>6</b>	<b>PARTS LIST</b> .....	<b>20</b>
UNCRATING MACHINE .....	6	MAIN HOUSING GROUP .....	20
INSTALLING BATTERIES .....	6	PAD DRIVER GROUP .....	22
<b>MACHINE SETUP</b> .....	<b>7</b>	DRIVE GROUP, 2550 MODEL .....	24
INSTALLING PAD .....	7	WHEEL GROUP, 2510 MODEL .....	26
INSTALLING DUST CONTROL BAG .....	7	CONTROL CONSOLE GROUP, 2550 MODEL .....	28
ADJUSTING CONTROL GRIP HEIGHT .....	8	CONTROL CONSOLE GROUP, 2510 MODEL .....	30
<b>MACHINE OPERATION</b> .....	<b>8</b>	ELECTRICAL/BATTERY GROUP .....	32
PRE-OPERATION .....	8	<b>OPTIONS</b> .....	<b>34</b>
BURNISHING WITH 2510 MODEL .....	8	HOUR METER KIT .....	34
BURNISHING WITH 2550 MODEL .....	9	EMERGENCY STOP SWITCH KIT .....	34
WHILE OPERATING MACHINE .....	9	KEY SWITCH KIT .....	34
EMERGENCY STOP SWITCH (OPTION) ..	10	PARKING BRAKE KIT .....	35
CIRCUIT BREAKERS .....	10	FLASHING LIGHT KIT .....	35
<b>CHARGING BATTERIES</b> .....	<b>10</b>		
<b>MACHINE MAINTENANCE</b> .....	<b>11</b>		
DAILY MAINTENANCE .....	12		
WEEKLY MAINTENANCE .....	12		
MONTHLY MAINTENANCE .....	12		
QUARTERLY MAINTENANCE .....	12		
BATTERY MAINTENANCE .....	13		
<b>TRANSPORTING MACHINE</b> .....	<b>13</b>		
<b>STORING MACHINE</b> .....	<b>13</b>		
<b>RECOMMENDED STOCK ITEMS</b> .....	<b>13</b>		

---

## SAFETY PRECAUTIONS

---

This machine is intended for commercial use. It is designed to burnish smooth floors in an indoor environment and is not constructed for any other use. Use only recommended burnishing pads.

All operators must read, understand and practice the following safety precautions.

The following safety alert symbols are used throughout this manual as indicated in their description.

 **WARNING:** To warn of hazards or unsafe practices which could result in severe personal injury or death.

**FOR SAFETY:** To identify actions which must be followed for safe operation of equipment.

The following information signals potentially dangerous conditions to the operator or equipment:

### FOR SAFETY

1. **Do not operate machine:**
  - Unless trained and authorized.
  - Unless operation manual is read and understood.
  - In flammable or explosive areas unless designed for use in those areas.
  - Without dust bag in place.
2. **Before starting machine:**
  - Make sure all safety devices are in place and operate properly.
3. **When using machine:**
  - Go slow on inclines and slippery surfaces.
  - Use care when reversing machine.
  - Always follow safety and traffic rules.
  - Report machine damage or faulty operation immediately.
4. **Before leaving or servicing machine:**
  - Stop on level surface.
  - Turn off machine.
  - Set parking brake, if equipped.

5. **When servicing machine:**
  - Avoid moving parts. Do not wear loose jackets, shirts, or sleeves.
  - Block machine tires before jacking machine up.
  - Use hoist or jack of adequate capacity to lift machine.
  - Disconnect battery connections before working on machine.
  - Wear protective gloves when handling batteries or battery cables.
  - Avoid contact with battery acid.
  - Use manufacturer supplied or approved replacement parts.
6. **When transporting machine:**
  - Do not lift machine if batteries are installed.

 **WARNING:** Batteries emit hydrogen gas. Explosion or fire can result. Keep sparks and open flame away. Keep battery compartment open when charging.

 **WARNING:** Flammable materials or reactive metals can cause explosion or fire. Do not pick up.

 **WARNING:** Moving parts. Turn off power before working on machine.

MACHINE COMPONENTS

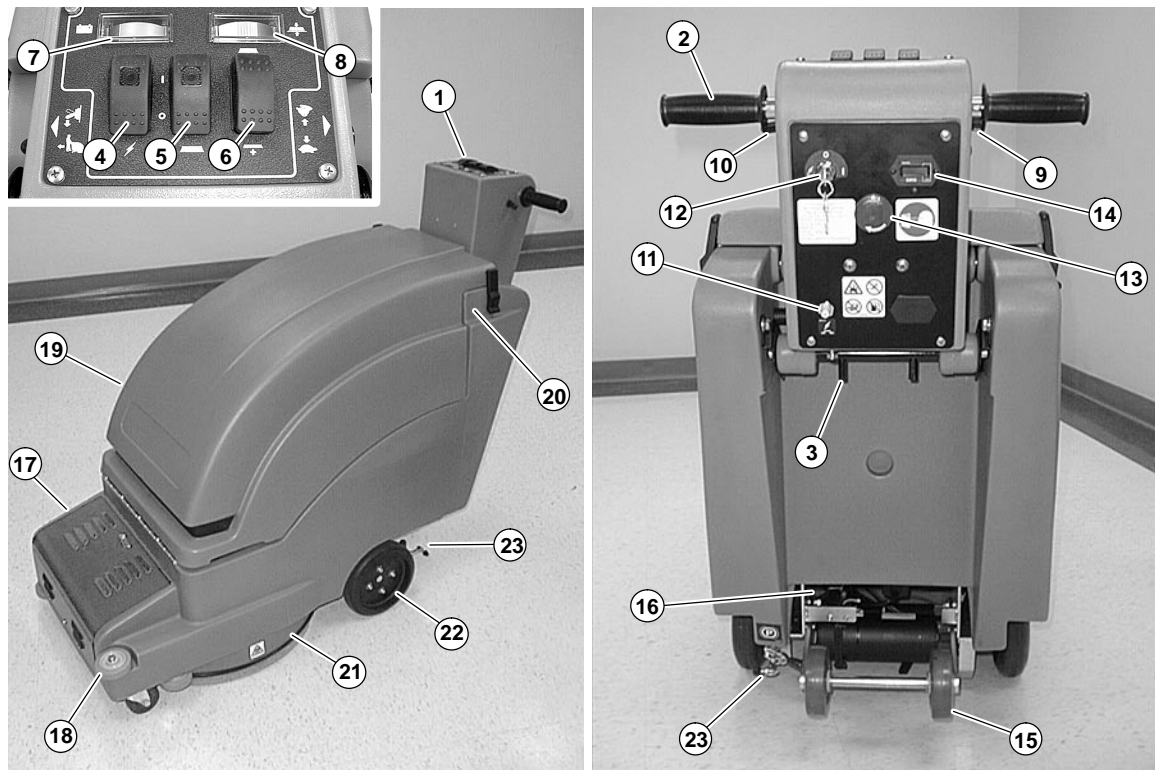

- |   |   |
|---|---|
| <ul style="list-style-type: none"> <li>1. Adjustable Control Console</li> <li>2. Control Grips</li> <li>3. Console Height Adjustment Levers</li> <li>4. Main ON/OFF Switch</li> <li>5. Pad ON/OFF Switch (2550 Model)</li> <li>6. Pad Pressure Switch</li> <li>7. Battery Meter</li> <li>8. Pad Pressure Meter</li> <li>9. Speed Control Knob (2550 Model)</li> <li>10. Reverse Trigger (2550 Model)</li> <li>11. Main Circuit Breaker Button</li> <li>12. Key Switch (Optional)</li> </ul> | <ul style="list-style-type: none"> <li>13. Emergency Stop Switch (Optional – 2550 Model)</li> <li>14. Hour Meter (Optional)</li> <li>15. Rear Tilt Wheels – for pad installation</li> <li>16. Automatic Safety Shut-Off Switch – for pad installation</li> <li>17. Dust Control Bag Compartment</li> <li>18. Wall Rollers</li> <li>19. Battery Compartment Hood</li> <li>20. Battery Charge Plug</li> <li>21. Pad Driver</li> <li>22. Main Wheels</li> <li>23. Parking Brake (Optional – 2550 Model)</li> </ul> |
|---|---|

CONTROL PANEL SYMBOLS

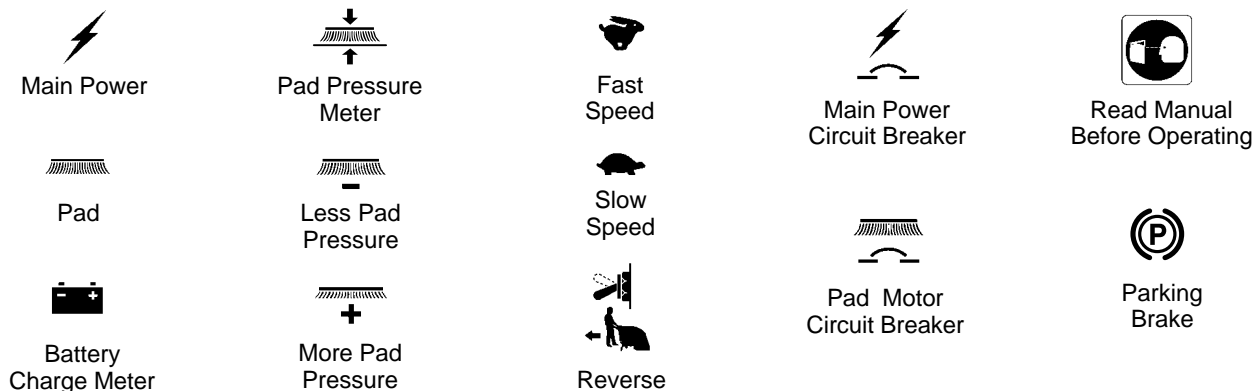

# OPERATION

---

## MACHINE INSTALLATION

---

### UNCRATING MACHINE

Carefully check carton for signs of damage. Report damages at once to carrier.

Check Machine Contents to ensure package is complete. Contact distributor for missing items.

#### Machine Contents:

2–Battery Cables

1–Battery Tray

1–Dust Control Bag

3–12V Batteries (Optional)

1–Battery Charger (Optional)

Burnishing Pads sold separately

To uncrate your machine, remove straps and carefully lift or use a ramp to remove machine from pallet. Do not roll machine off pallet, damage may result.

**ATTENTION: Install batteries after removing machine from pallet.**

**FOR SAFETY: When transporting machine, do not lift machine if batteries are installed.**

---

### INSTALLING BATTERIES

**⚠ WARNING: Batteries emit hydrogen gas. Explosion or fire can result. Keep sparks and open flame away. Keep battery compartment open when charging.**

**FOR SAFETY: When servicing machine, wear protective gloves when handling batteries or battery cables. Avoid contact with battery acid.**

#### Recommended Battery Specifications:

Three 12 volt, deep cycle, 215 amp hour batteries. Part Number #600394. Maximum battery dimensions are 178 mm (7 in)W x 394 mm (15.5 in)L x 362 mm (14.25 in) H.

1. Park machine on a level surface and set parking brake, if equipped (Figure 1).



FIG. 1

2. Turn OFF all switches. Remove key, if equipped.
3. Unlatch battery hood latches and open battery compartment. Remove loose battery cables (Figure 2).



FIG. 2

4. Carefully install batteries into battery tray and arrange battery posts as shown. After batteries are in place remove battery handles to allow clearance for battery hood (Figure 3).

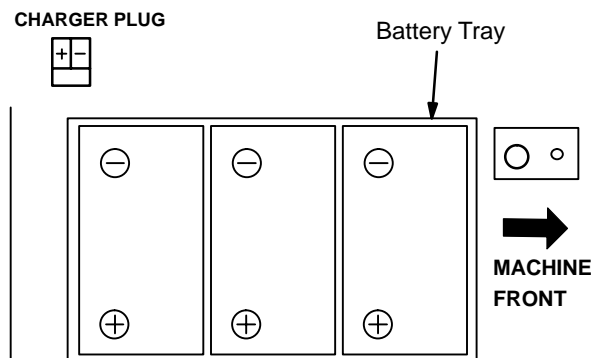

FIG. 3

**ATTENTION: Do not drop batteries into compartment. Battery and machine housing damage may result.**

5. Connect cables to battery posts as shown, RED TO POSITIVE & BLACK TO NEGATIVE (Figure 4).

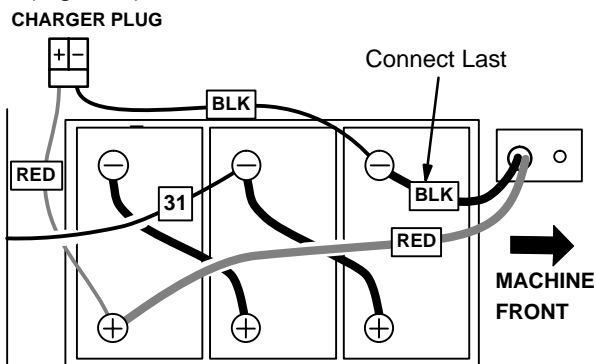

FIG. 4

6. Double check cable connections and close hood, fasten hood latches.

## MACHINE SETUP

### INSTALLING PAD

**NOTE:** Consult your authorized distributor for pad recommendations.

#### Pad Specifications:

- For 2000 RPM burnishing.
- 25.4mm (1.0 in) thickness
- 508mm (20 in) dia. with 89mm (3.5 in) center hole.

**NOTE:** Machine is not designed for spray buffing.

1. Turn off machine and tilt machine back on rear wheels (Figure 5).

**FOR SAFETY:** Before leaving or servicing machine, stop on level surface, turn off machine, and set parking brake, if equipped.

**NOTE:** When machine is tilted back completely, power to pad motor automatically shuts off.

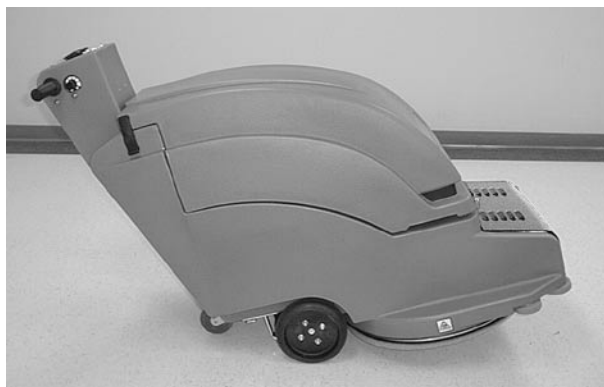

FIG. 5

**ATTENTION:** Do not leave machine tilted back for an extended time, battery acid may leak.

2. Remove plastic center lock from pad driver by turning lock counterclockwise.
3. Position pad centered on pad driver and replace centerlock securely (Figure 6).



FIG. 6

**NOTE:** Make sure centerlock does not cross thread or floor damage may occur.

**ATTENTION:** Do not operate machine without a pad and/or centerlock in place.

4. After installing pad, return machine to operating position.

### INSTALLING DUST CONTROL BAG

1. Open dust control bag compartment at front of machine.
2. Slide bag on plastic snout. Close compartment (Figure 7).



FIG. 7

3. Empty or replace bag daily. Do not allow bag to fill beyond half full.

# OPERATION

## ADJUSTING CONTROL GRIP HEIGHT

The machine has three control grip height settings.

1. Locate two spring loaded levers below console.
2. Squeeze levers together and lift or lower control grips to a comfortable operating height (Figure 8).

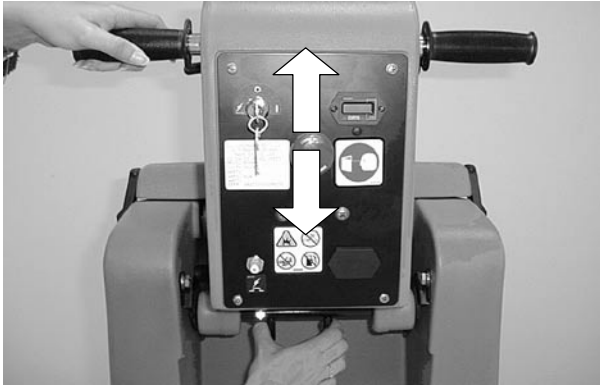

FIG. 8

## MACHINE OPERATION

**FOR SAFETY: Do not operate machine unless operator manual is read and understood.**

### PRE-OPERATION

1. Sweep floor and remove debris.
2. Check condition of pad.
3. Check battery charge level (*For accurate reading pad must be spinning*).
4. Check that dust control bag is installed.
5. Make sure floor is dry.

## BURNISHING WITH 2510 MODEL

1. Turn on key, if equipped then turn on main power switch.
2. Twist control grips forward to lower pad to floor and to start pad motor (Figure 9).



FIG. 9

3. Begin burnishing by pushing machine forward.

**FOR SAFETY: When using machine, go slow on inclines and slippery surfaces.**

4. Adjust pad pressure meter within Green Zone. Press the pad pressure switch to decrease or increase pressure. For best results adjust needle as shown (Figure 10).

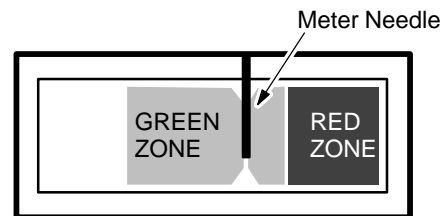

FIG. 10

**ATTENTION: Do not operate machine in red zone, floor damage and brush motor overload may result.**

**NOTE: If machine vibrates, realign pad.**

**ATTENTION: Keep machine moving at all times to prevent floor damage.**

5. To stop burnishing, release grips. The pad will automatically raise to the transport position.



## BURNISHING WITH 2550 MODEL

1. Release parking brake lever, if equipped.
2. Turn on key, if equipped, then turn on main power and pad switches.
3. Turn speed control knob to slowest speed. This will prevent an abrupt take off (Figure 11).



FIG. 11

4. Twist control grips forward to begin burnishing. Gradually turn speed control knob to desired cleaning speed (Figure 12).

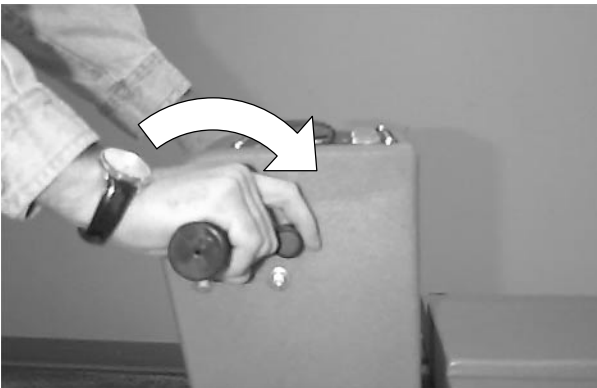

FIG. 12

**FOR SAFETY: When using machine, go slow on inclines and slippery surfaces.**

5. Adjust pad pressure meter within Green Zone. Press the pad pressure switch to decrease or increase pressure. For best results adjust needle as shown (Figure 13).

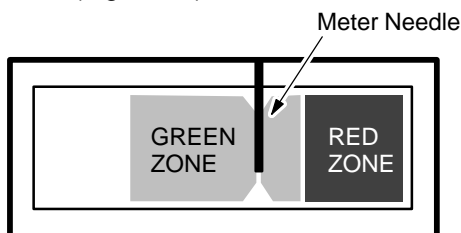

FIG. 13

**ATTENTION: Do not operate machine in red zone, floor damage and brush motor overload may result.**

**NOTE: If machine vibrates, realign pad.**

**ATTENTION: Keep machine moving at all times to prevent floor damage.**

6. To stop machine, release grips. The pad will automatically raise to the transport position.
7. To operate machine in reverse, simply pull reverse trigger, one speed (Figure 14).

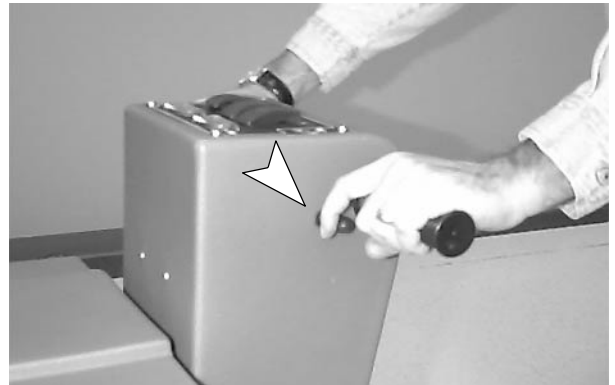

FIG. 14

7. To transport machine, turn off pad switch and twist control grips. Pad will automatically raise to the transport position (Figure 15).

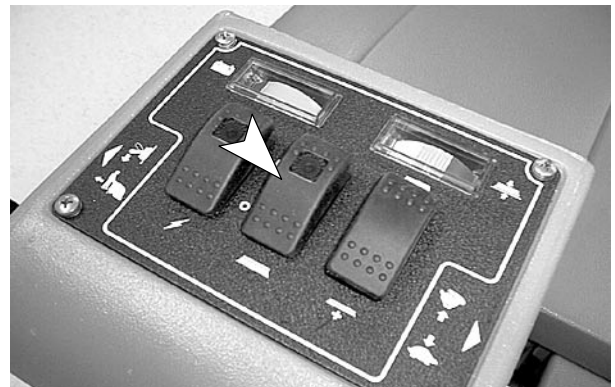

FIG. 15

## WHILE OPERATING MACHINE

1. Always operate with caution when burnishing around walls and obstacles.
2. Always reduce speed to maintain control when turning.
3. Stay clear of floor obstructions, such as electrical plates or grates, they will destroy pad. Tilt machine back to avoid floor obstructions.

**NOTE: When machine is tilted back completely, power to pad motor automatically shuts off.**

4. Change or turn pads over when soiled.
5. Check battery meter's discharge level periodically. Recharge when needle drops into red zone.

## OPERATION

**ATTENTION:** Do not operate machine in red zone, floor damage and brush motor overload may result.

6. If pad motor circuit breaker trips, reduce pad pressure and/or replace soiled pad.

**FOR SAFETY:** Before leaving or servicing machine, stop on level surface, turn off machine, and set parking brake, if equipped.

**FOR SAFETY:** When transporting machine, do not lift machine if batteries are installed.

### EMERGENCY STOP SWITCH (2550 Model – Optional)

To stop machine during an emergency, hit the red emergency stop switch located at rear of control console. The emergency stop switch immediately stops all power to machine.

To reset emergency stop switch, shut off all switches and turn red button to the right. Resume normal operation (Figure 16).



FIG. 16

### CIRCUIT BREAKERS

Machine is equipped with two resettable circuit breakers, Main (15A) and Pad Motor (80A), to protect machine from damage. If pad motor circuit breaker should trip, determine cause, allow motor to cool, then reset. Pad circuit breaker will trip due to excessive pad overload. Change pad or reduce pad pressure if breaker should trip. Pad motor circuit breaker button is located under battery hood at front of machine (Figure 17).

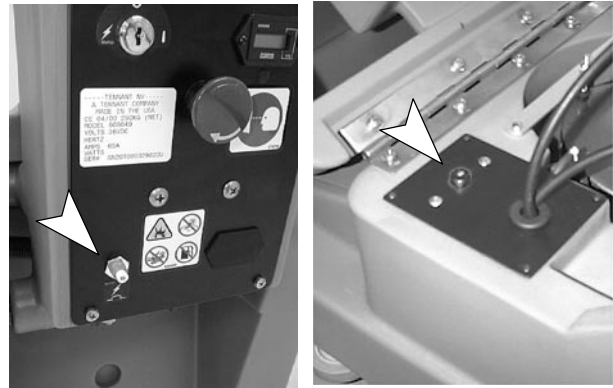

FIG. 17

## CHARGING BATTERIES

**NOTE:** Recharge batteries **ONLY** after a total of 30 minutes of use or more. This will prolong battery life.

The following charging instructions are intended for supplied 36V chargers only. Only use a charger with the following specifications to prevent battery damage.

### CHARGER SPECIFICATIONS:

- OUTPUT VOLTAGE - 36 VOLTS
- OUTPUT CURRENT - 25 AMPS MAXIMUM
- AUTOMATIC SHUTOFF CIRCUIT
- FOR DEEP CYCLE BATTERY CHARGING

**NOTE:** For optimum machine operation, keep batteries charged at all times. Never let batteries set in a discharge condition for lengthy periods.

**⚠ WARNING:** Batteries emit hydrogen gas. Explosion or fire can result. Keep sparks and open flame away. Keep battery compartment open when charging.

**FOR SAFETY:** When servicing machine, wear protective gloves when handling batteries or battery cables. Avoid contact with battery acid.

1. Transport machine to a flat, dry surface in a well-ventilated area for charging.
2. Turn off all switches and key. Set parking brake, if equipped.

**FOR SAFETY:** Before leaving or servicing machine, stop on level surface, turn off machine, and set parking brake, if equipped.

- Unlatch battery hood and open battery compartment (Figure 18).



FIG. 18

- Before charging batteries, check electrolyte level (A) in each battery cell. Do not charge batteries unless electrolyte is slightly covering battery plates (B). If battery plates (B) are exposed, add just enough distilled water to slightly cover plates, level (A). Never add acid to batteries. DO NOT overfill. Batteries can overflow during charging due to expansion. Replace cell caps before charging (Figure 19).

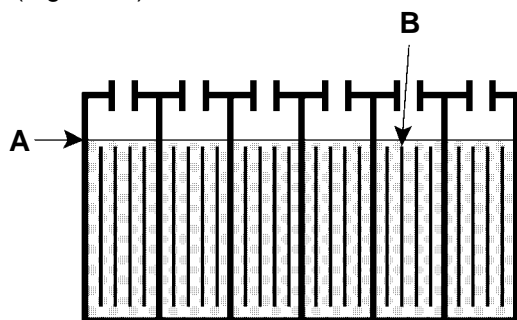

FIG. 19

- With charger's power supply cord unplugged, connect battery charger into machine as shown. Flip up hood support stand and rest hood on stand to promote ventilation (Figure 20).

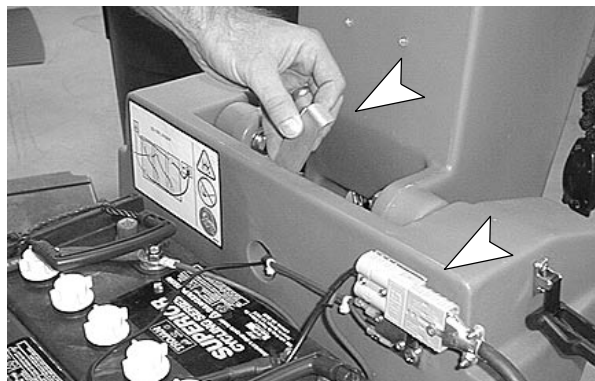

FIG. 20

**NOTE:** Once the charger is connected, machine becomes inoperable.

- Then, plug charger's power supply cord into a grounded wall outlet (Figure 21).

**FOR SAFETY:** Do not operate charger unless cord is properly grounded.

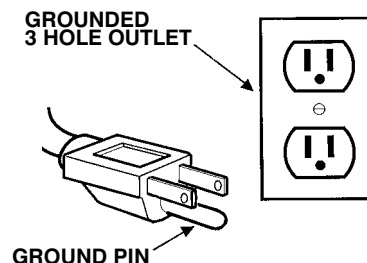

FIG. 21

- Charger will automatically begin charging and shut off when fully charged.
- After charger has turned off, unplug charger from wall outlet first then disconnect charger from machine.
- Recheck battery electrolyte level (A) after charging. Add distilled water to bring level 1cm from bottom of sight tubes (B). Replace cell caps securely and wipe off the top of batteries with a clean cloth (Figure 22).

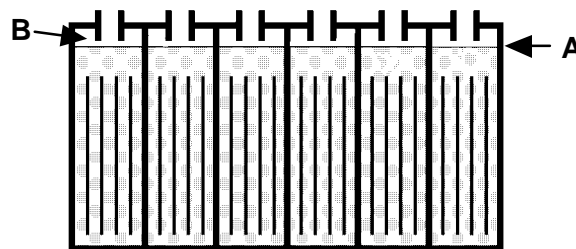

FIG. 22

## MACHINE MAINTENANCE

To keep machine in good working condition, simply follow machines daily, weekly and monthly maintenance procedures:

**FOR SAFETY:** Before leaving or servicing machine, stop on level surface, turn off machine, and set parking brake, if equipped.

**FOR SAFETY:** When servicing machine, disconnect battery connections before working on machine.

**FOR SAFETY:** When transporting machine, do not lift machine if batteries are installed.

# OPERATION

## DAILY MAINTENANCE (Every 4 Hours of Use)

1. Remove burnishing pad and clean or replace (Figure 23).



FIG. 23

2. Empty or replace dust control bag (Figure 24).



FIG. 24

3. Clean machine housing with damp cloth (Figure 25).



FIG. 25

4. Check fluid level in battery cells (See BATTERY MAINTENANCE).
5. Recharge batteries (See CHARGING BATTERIES).

**NOTE:** Recharge batteries *ONLY* after a total of 30 minutes of use or more. This will prolong battery life.

## WEEKLY MAINTENANCE (Every 20 Hours of Use)

1. Clean battery tops of corrosion (See BATTERY MAINTENANCE).
2. Check for loose or corroded battery cables.

## MONTHLY MAINTENANCE (Every 80 Hours of Use)

1. Lubricate caster with a water resistant grease.
2. Lubricate wheel grease fittings with a water resistant grease (2510 Model).
3. Check machine for loose nuts and bolts.
4. Check condition of dust skirt, replace if worn (Figure 26).

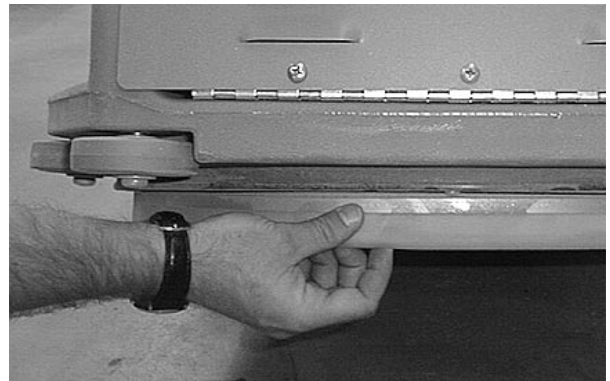

FIG. 26

## QUARTERLY MAINTENANCE (Every 250 Hours of Use)

Check motor(s) for carbon brush wear, replace brushes if worn to a length of 10mm (0.38 in) or less (Figure 27). Contact your Authorized Service Center for carbon brush inspection.

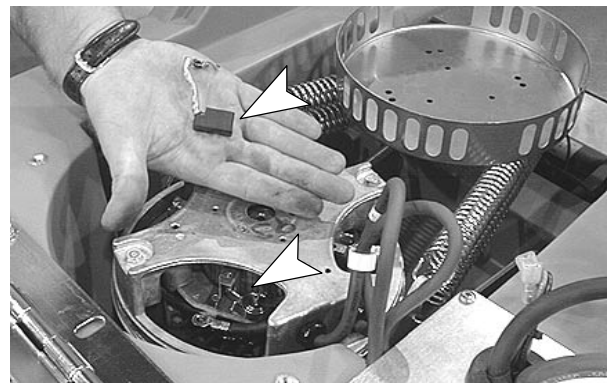

FIG. 27

**BATTERY MAINTENANCE**

**⚠ WARNING: Batteries emit hydrogen gas. Explosion or fire can result. Keep sparks and open flame away. Keep battery compartment open when charging.**

**FOR SAFETY: When servicing machine, wear protective gloves when handling batteries or battery cables. Avoid contact with battery acid.**

1. Always follow proper charging instructions (see CHARGING BATTERIES).
2. Each week **after** charging, check fluid level (A) in each battery cell of all batteries. The level should be 1cm from bottom of sight tubes (B). If needed, add just enough distilled water to raise level 1cm from bottom of sight tubes. **DO NOT** overfill (Figure 28).

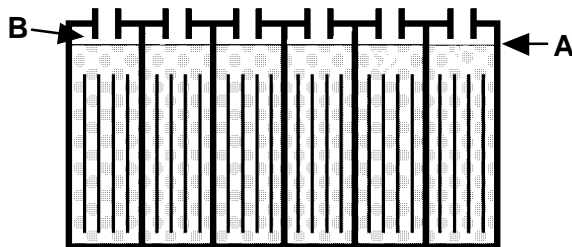

**FIG. 28**

3. Keep battery tops and terminals clean and dry.
  - a. Mix a strong solution of baking soda and water (Figure 29).



**FIG. 29**

- b. Brush solution sparingly over battery tops, terminals, and cable connectors.

**NOTE: Do not allow baking soda solution to enter battery cells.**

  - c. Use wire brush to clean terminals and cable connections.
  - d. After cleaning, apply a coating of clear battery post protectant to terminals and cable connections.
4. Check for loose or worn cables. Replace if worn.

**TRANSPORTING MACHINE**

When transporting machine by use of trailer or truck, be certain to follow tie-down procedures below:

**ATTENTION: Tilt machine back when loading and unloading to prevent dust skirt damage.**

1. Load machine using a recommended loading ramp.

**NOTE: If lifting machine, you must remove batteries.**

**FOR SAFETY: When transporting machine, do not lift machine if batteries are installed.**

2. Position front of machine up against front of trailer or truck bed.
3. Set parking brake, if equipped, and place blocks behind the main wheels.
4. Place tie-down straps over top of machine and secure straps to floor. It may be necessary to install tie-down brackets to the floor of your trailer or truck.

**NOTE: Do not use control grips to secure machine for transporting.**

**ATTENTION: Do not transport machine tilted back, battery acid may leak.**

**STORING MACHINE**

Store machine in a dry area in the upright position.

**ATTENTION: Do not store machine tilted back, battery acid may leak.**

**ATTENTION: Do not expose to rain. Store indoors.**

**RECOMMENDED STOCK ITEMS**

Refer to the Parts List section in this manual for recommended stock items. Stock Items are clearly identified with a bullet preceding the parts description. See example below:

Ref.	Part No.	Description	Qty.
1	701103	ASM.,STANDPIPE	1
2	180613	●FLOAT, SHUTOFF	1
3	230187	NIPPLE	1
4	101714	●GASKET	1
5	210240	NUT, FLANGED	1

# OPERATION

## TROUBLE SHOOTING

PROBLEM	CAUSE	SOLUTION
No Power	Faulty main switch.	Contact Service Center.
	Faulty key switch, if equipped.	Contact Service Center.
	Faulty battery(s).	Replace battery(s).
	Loose battery cable.	Tighten loose cables.
	Improper battery cable connection.	See Installing Batteries.
	Tripped Main circuit breaker.	Determine cause and reset breaker.
	Charger is connected.	Disconnect Battery charger.
	Emergency stop switch activated, if equipped.	Turn button to reset.
Pad motor does not operate	Faulty roll switch.	Contact Service Center.
	Tripped pad motor circuit breaker	Replace pad/adjust pressure and reset breaker.
	Faulty contactor.	Contact Service Center.
	Faulty wiring.	Contact Service Center.
	Faulty pad drive motor.	Contact Service Center.
	Worn carbon brushes	Contact Service Center.
	Tilt safety switch is activated or faulty.	Lower machine from tilt position.
Drive motor does not operate or operates incorrectly(2550 Model).	Parking brake is set, if equipped.	Release parking brake.
	Faulty roll switch.	Contact Service Center.
	Faulty speed control board or connection.	Contact Service Center.
	Faulty solenoid.	Contact Service Center.
	Faulty drive motor.	Contact Service Center.
	Faulty wiring.	Contact Service Center.
	Worn carbon brushes.	Contact Service Center.
	Faulty potentiometer or speed control board.	Contact Service Center.
	Loose wire connection.	Contact Service Center.
Short run time.	Low battery charge.	Charge batteries.
	Defective battery cell(s).	Replace battery.
	Batteries need maintenance.	See Battery Maintenance.
	Faulty battery charger.	Replace charger.

**SPECIFICATIONS**

<b>Model</b>	<b>2510</b>	<b>2550</b>
LENGTH	1321mm (52 in)	1321mm (52 in)
WIDTH	609mm (24 in)	609mm (24 in)
HEIGHT	1016mm (40 in)	1016mm (40 in)
WEIGHT WITH BATTERIES	238 Kg (525 lb)	245 Kg (540 lb)
DRIVE SYSTEM	N/A (Pad assisted)	.2 hp Transaxle
DRIVE SPEED	N/A	0–73m (0–240 ft) per min.
PAD WIDTH	508mm (20 in)	508mm (20 in)
PAD MOTOR	36V, 3hp, 2000 rpm, 80A, 2238W	36V, 3hp, 2000 rpm, 80A, 2238W
PAD PRESSURE	Variable 7–19 kg (15–40 lb)	Variable 7–19 kg (15–40 lb)
DUST CONTROL BAG	Cloth – 98% @ 1.0 micron	Cloth Bag – 98% @ 1.0 micron
BATTERIES	3–215amp/hour, 12v deep cycle	3–215amp/hour, 12v deep cycle
RUN TIME, CONTINUOUS	Up to 2.4 hours	Up to 2.2 hours
DECIBEL RATING AT OPERATOR'S EAR, INDOORS ON TILE	70dB(A)	70dB(A)

## SpeedGleam® Wiring

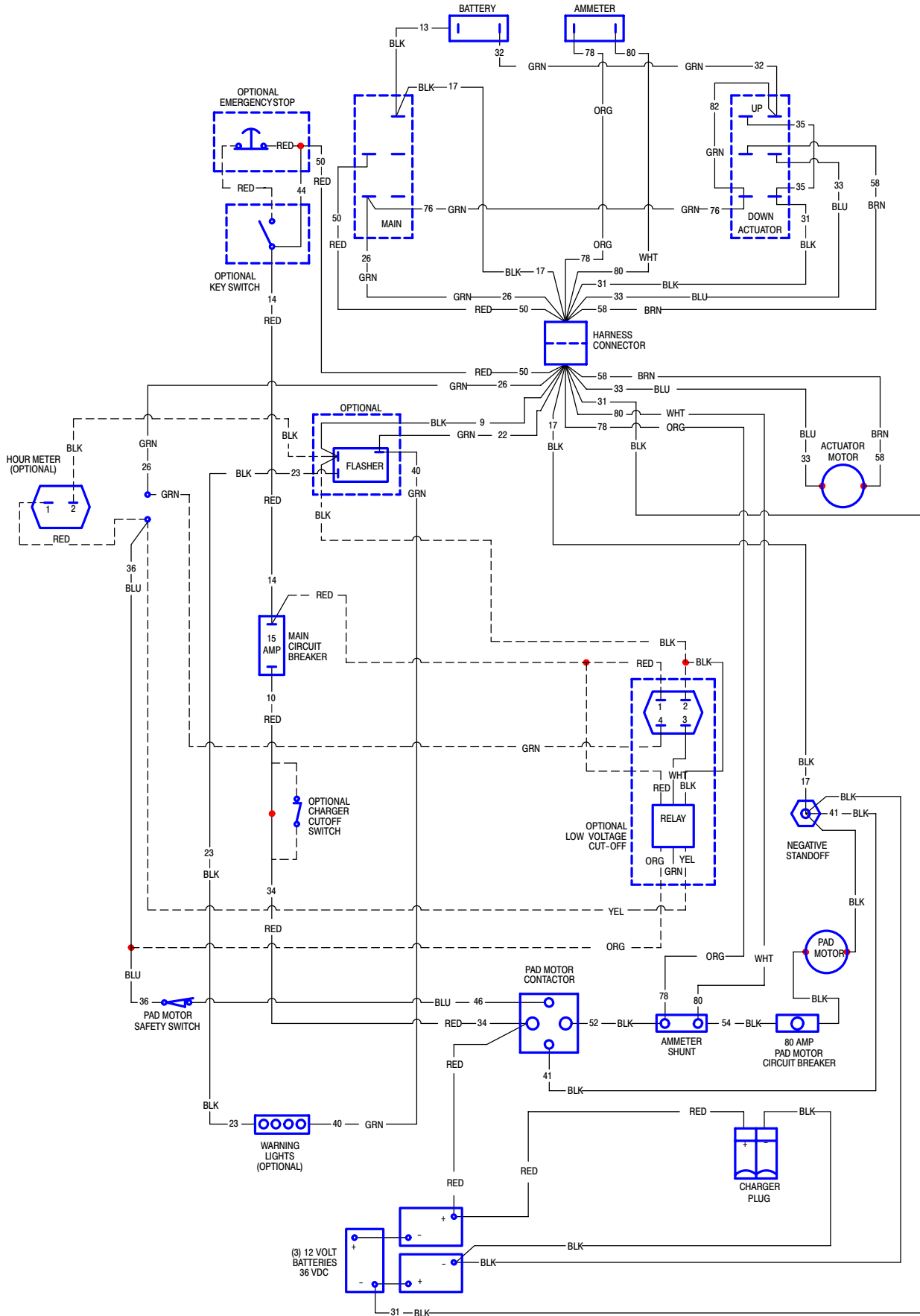



SpeedGleam® Ladder

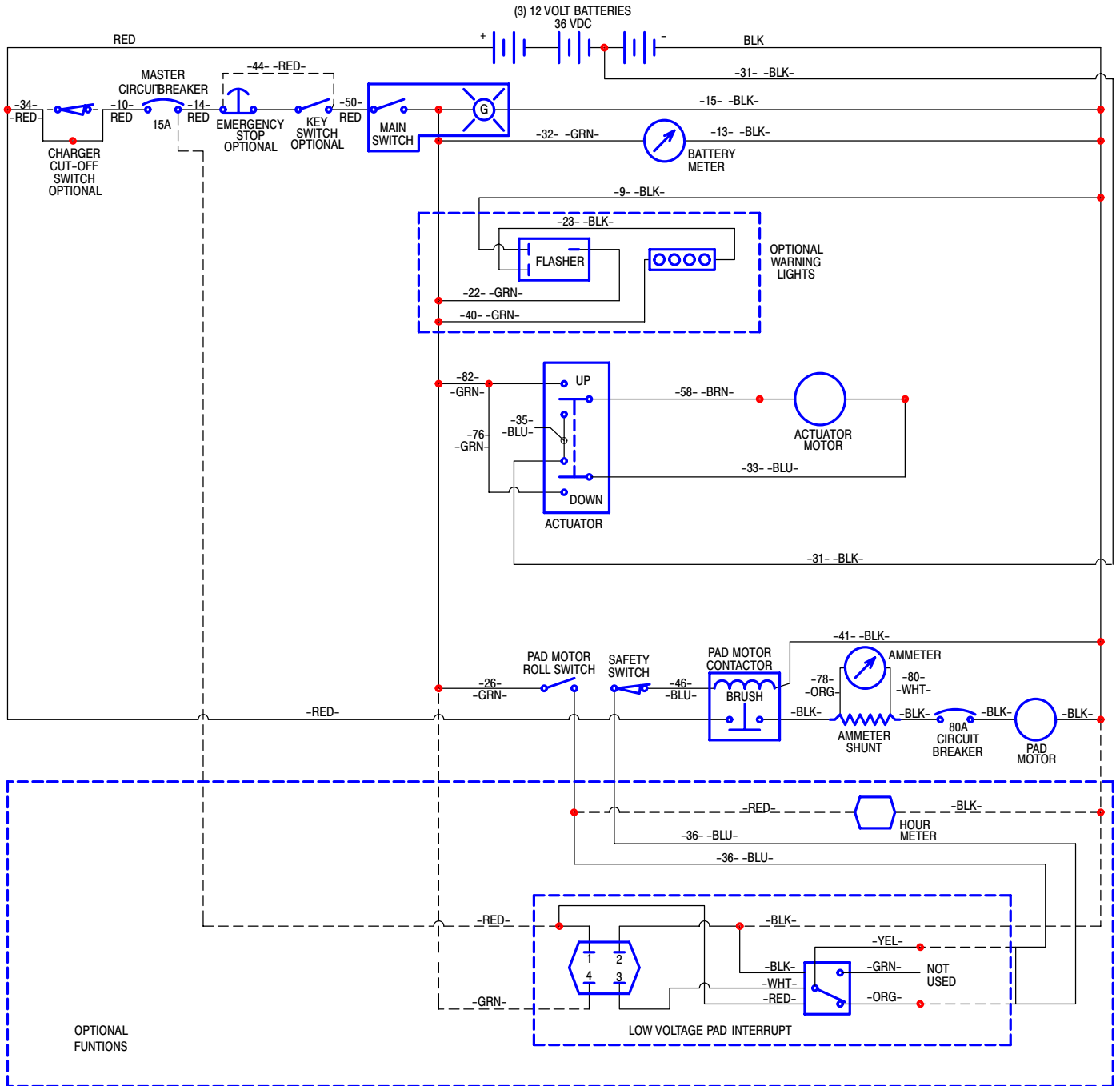

## SpeedGleam® Plus Wiring

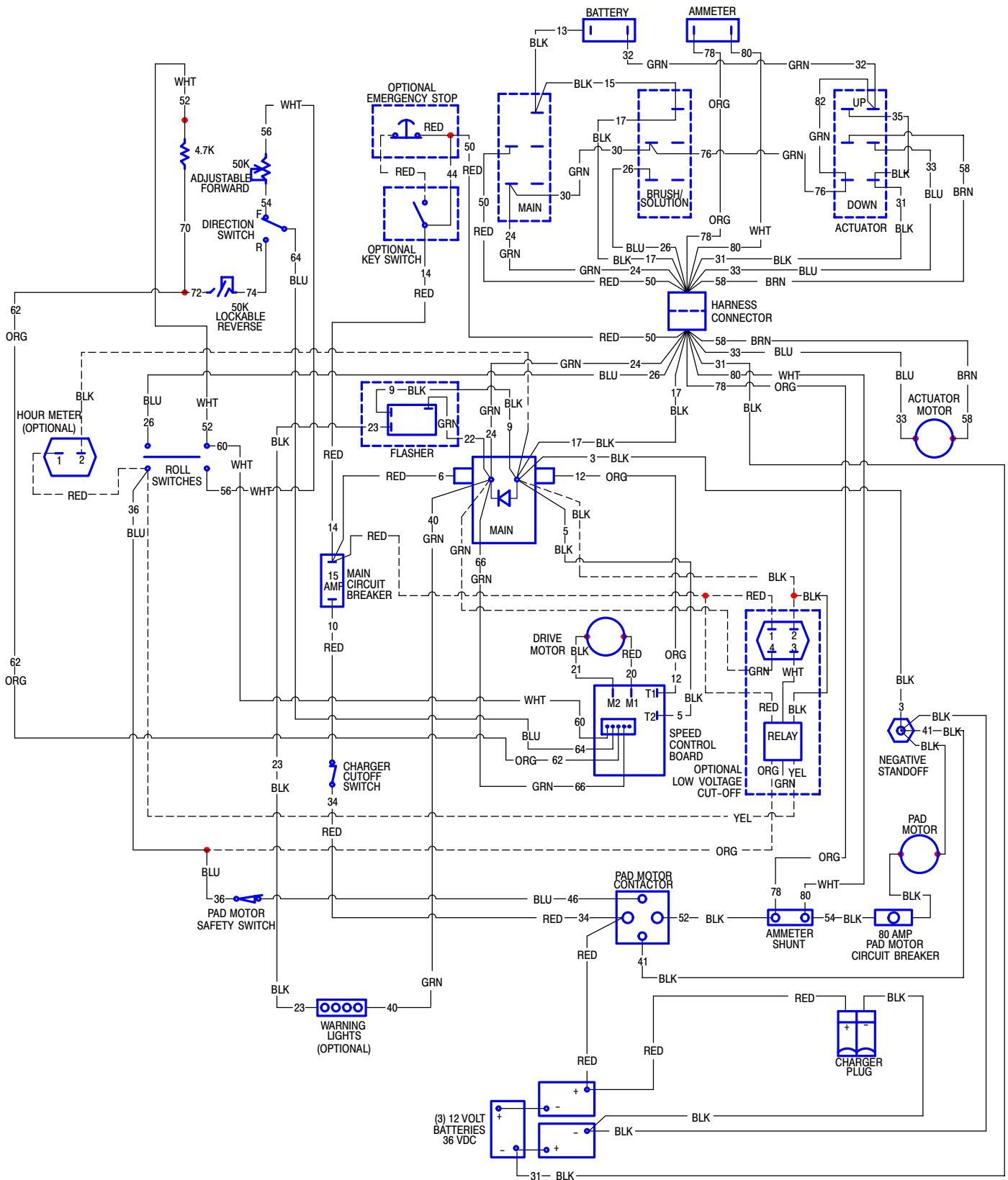

## SpeedGleam® Plus Ladder

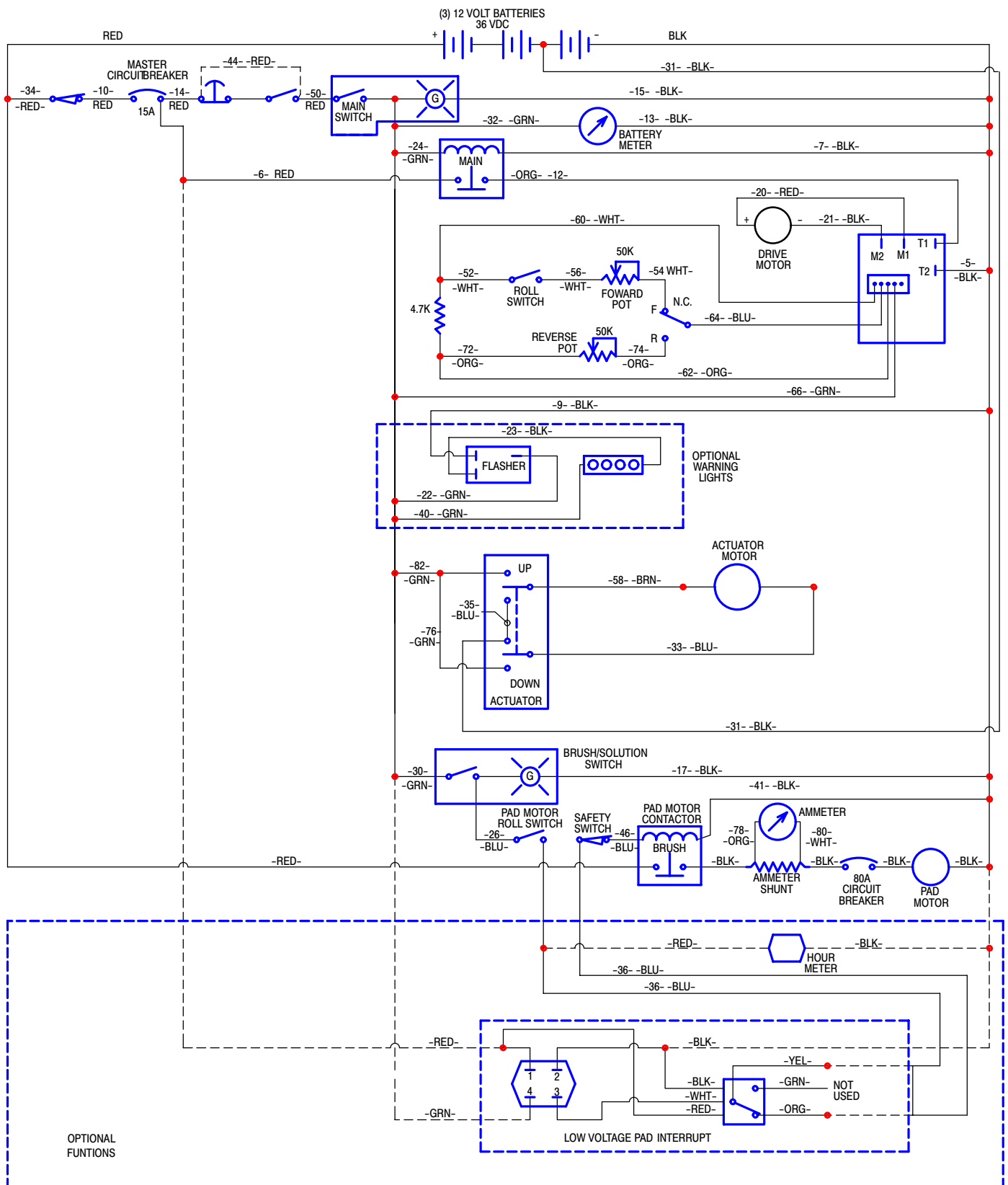

MAIN HOUSING GROUP

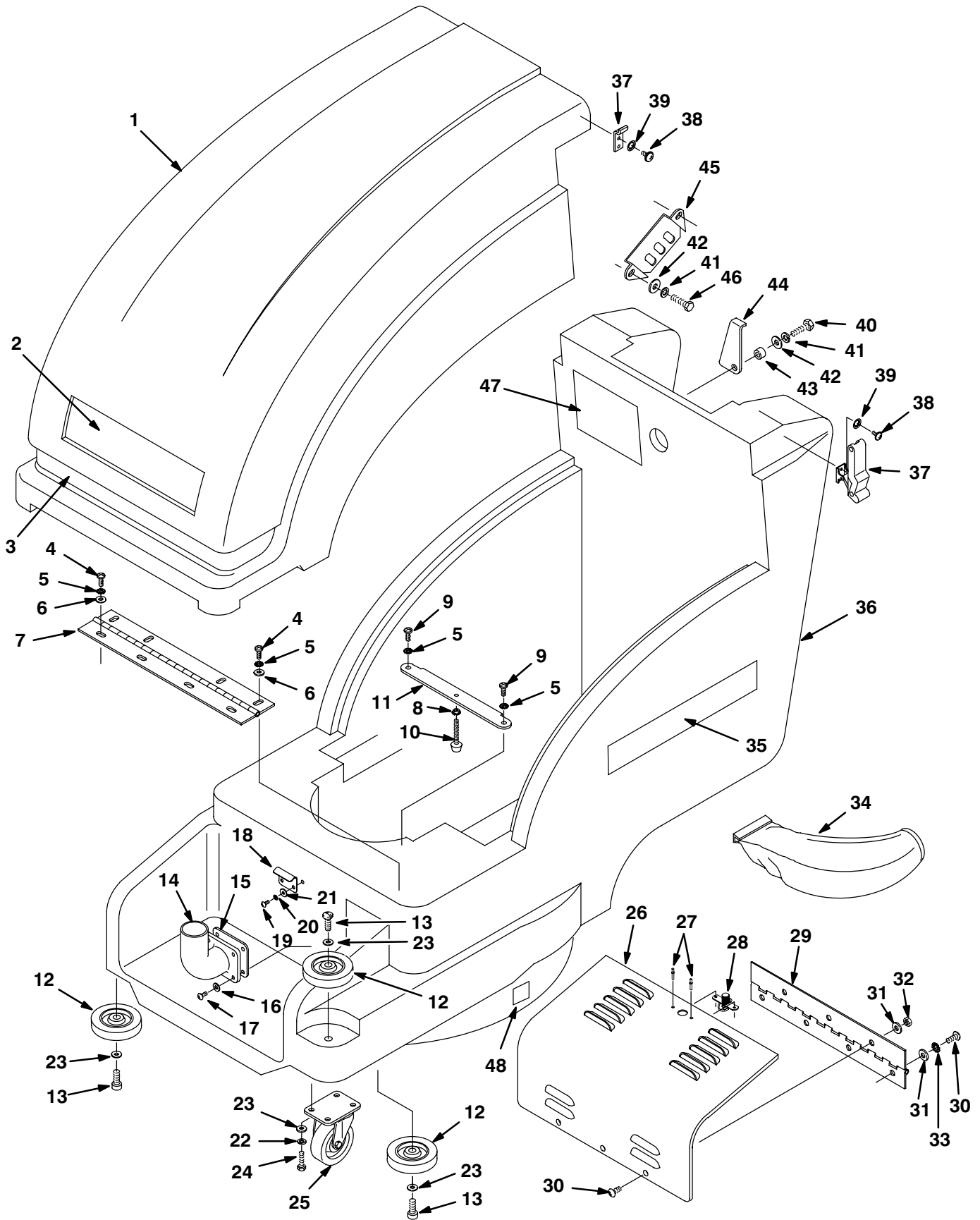

## MAIN HOUSING GROUP

REF	PART #	DESCRIPTION	QTY.
1	608381	COVER, BATTERY COMPARTMENT, GREEN	1
2	608184	DECAL, NOBLES LOGO	1
3	604297	DECAL, RECESS BLACK	1
4	578187000	SCREW, M6X1.0X12	8
5	140016	WASHER, 1/4 LOCK	10
6	140000	WASHER, 1/4 FLAT	8
7	603268	HINGE, HOOD	1
8	140524	NUT, 1/4 X 20 KEP	1
9	578187000	SCREW, M6X1.0X12	2
10	606684	STOP, MOTOR	1
11	604276	BRACKET, MOTOR STOP	1
12	630450	WHEEL, RUBBER DIA 76 X 23 WD	4
13	603154	SCREW, M8X1.25X40	4
14	602721	ELBOW, DEFLECTOR RM-NAT	1
15	100121	GASKET, ELBOW 1/4"	1
16	140011	WASHER, 3/16 FLAT	4
17	069760103	SCREW, RNDPHL #10, 1.0	4
18	604295	PLATE, LATCH	1
19	578187000	SCREW, M6X1.0X12 PANPHL	2
20	140016	WASHER, 1/4 LOCK	2
21	140000	WASHER, 1/4 FLAT	2
22	140015	WASHER, 5/16 SPLITLOCK	4
23	140027	WASHER, 5/16 FLAT	8
24	140275	SCREW, M8X1.25X16 HXHDCP	4
25	103001	CASTER, SWIVEL 3"	1

REF	PART #	DESCRIPTION	QTY.
26	608512	COVER, DUST BAG, BLACK	1
27	140706	RIVET, POP 1/8	2
28	140962	LATCH, SPRING KNURLED	1
29	603269	HINGE, DUST COVER	1
30	578187000	SCREW, M6X1.0X12	7
31	140000	WASHER, 1/4 FLAT	7
32	140284	NUT, M6X1.0 NYLOCK	3
33	140016	WASHER, 1/4 LOCK	4
34	900210	●BAG, CLOTH (OPTION)	1
	604237	●BAG, PAPER FILTER PK=10	1
35	608383	DECAL, SPEEDGLEAM PLUS	2
	608459	DECAL, SPEEDGLEAM	2
36	608379	CHASSIS, GREEN	1
37	140932	LATCH, HOOD RUBBER	2
38	200070340	SCREW, M4X.7X8 PANPHL	8
39	140023	WASHER, #8 INT	8
40	140275	SCREW, M8X1.25X16 HXHDCP	1
41	140015	WASHER, 5/16 SPLITLOCK	5
42	140027	WASHER, 5/16 FLAT	5
43	611418	BUSHING, 5/16ID X 7/16OD X .14	1
44	604637	SUPPORT	1
45	230661	PLATE, LOCK CONTROL HOUSING	2
46	140275	SCREW, M8X1.25X16 HXHDCP	4
47	604304	DECAL, BATT HOOK-UP & CAUTIONS	1
48	578769	DECAL, MOVING PARTS	2

## ● RECOMMENDED STOCK ITEMS

PAD DRIVER GROUP

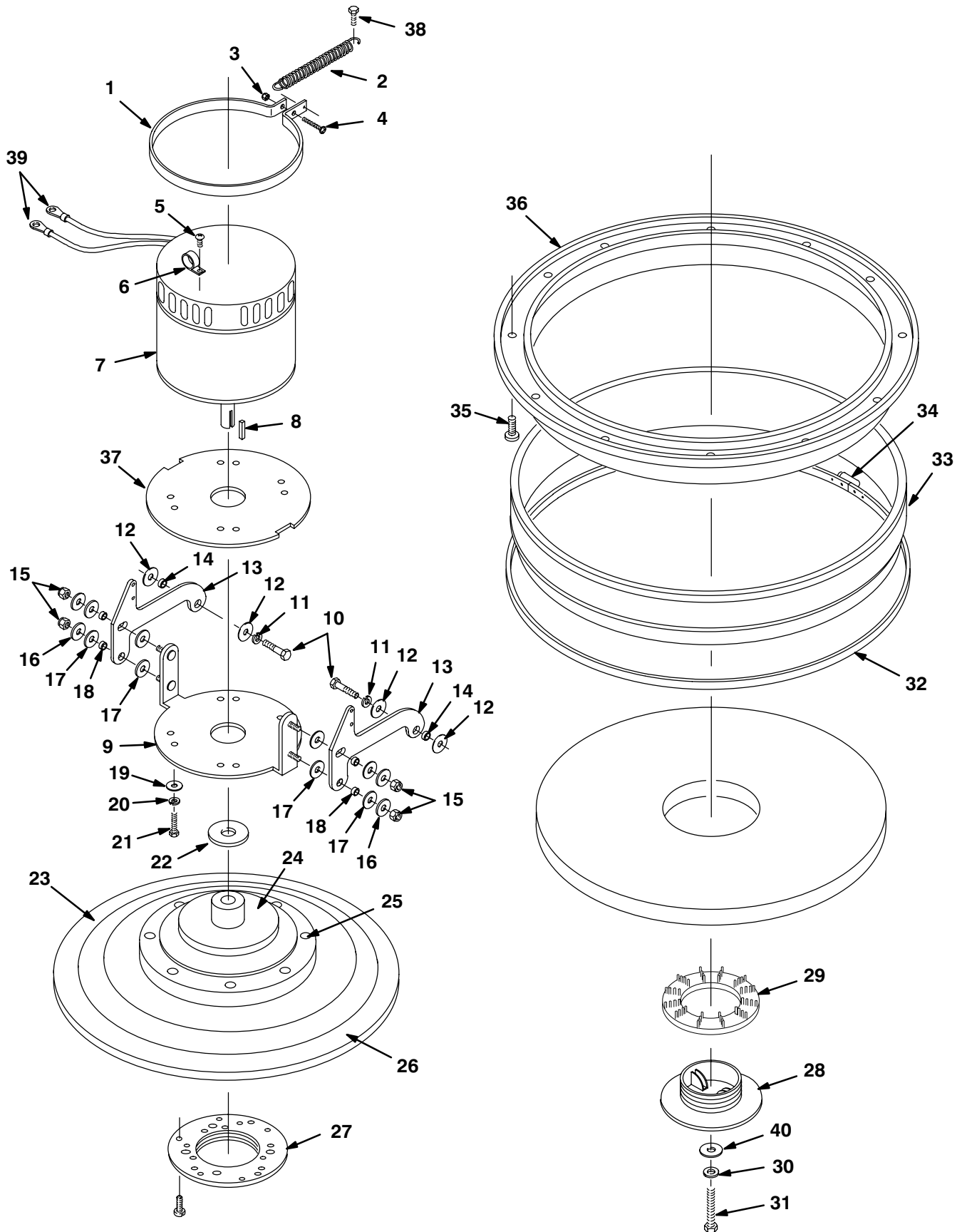

## PAD DRIVER GROUP

REF	PART #	DESCRIPTION	QTY.
1	604278	BRACKET, MOTOR	1
2	604333	SPRING, EXT 1/2X4X.063	1
3	140284	NUT, M6X1.0 NYLOCK	1
4	630431	SCREW, M6X1.0X40 HXHDPC	1
5	140890	SCREW, 10-24X1/2 TRSPHL	1
6	140323	CLAMP, NYLON 1/2" ID	1
▽ 7	603398	MOTOR, 36VDC 2000 RPM 3HP	1
	621478	BRUSH, CARBON	4
▲ 8	140628	KEY, MOTOR 3/16X1	1
9	600198	BRACKET, MOTOR	1
10	140352	SCREW, M12X1.75X25 HXHDSS	2
11	140024	WASHER, 1/2" LOCK	2
12	140045	WASHER, FLAT .510X1.25X.06	4
13	603273	LIFT ARM MOTOR	2
14	140139	BUSHING	2
15	600200	NUT, 3/8-16 JAM NYLOCK	4
16	140028	WASHER, 3/8 FLAT	4
17	630447	WASHER, NYLON	8
18	600191	BUSHING, 3/8X1/2X.260	4
19	140028	WASHER, 3/8 FLAT	4
20	140017	WASHER, 3/8 SPLIT LOCK	4

REF	PART #	DESCRIPTION	QTY.
21	140201	SCREW, 3/8-16X3/4 HXHDPC	4
22	069760023	WASHER, FLAT .77X1.26X.03	1
▽ 23	605348	ASM., DRIVER PAD	1
▲ 24	27900	HUB, PAD DRIVER	1
▲ 25	190177	SCREW & CAPS (PACK OF 8)	1
▲ 26	27071	DISC, FLEXIBLE	1
▲▽ 27	25707	ASM., CENTERLOCK	1
▲ 28	100101	RING, PAD RETAINER	1
29	572084000	WASHER, PAD DRIVER LOCK	1
30	41186	WASHER, 5/16 BELLEVILLE	1
31	140203	SCREW, 5/16-24X1-1/4 HXHDPC	1
32	605103	STRAP, 3/8X74 IN	1
33	603744	●SKIRT, DUST CONTROL	1
34	230913	SCRU-SEAL & RACK	1
35	140340	SCREW, #10X5/8 PANPHL	6
36	230888	RING, DUST SHIELD	1
37	600195	SEAL, MOTOR BASE	1
38	600385	SCREW, M6X1.0X20 PANPHL	1
39	130162	TERMINAL, RING 1/4 8GA RED	2
40	25732	WASHER, FLAT 1.25X.359X.093	1

▽ ASSEMBLY

▲ INCLUDED IN ASSEMBLY

● RECOMMENDED STOCK ITEMS

DRIVE GROUP (Plus Model)

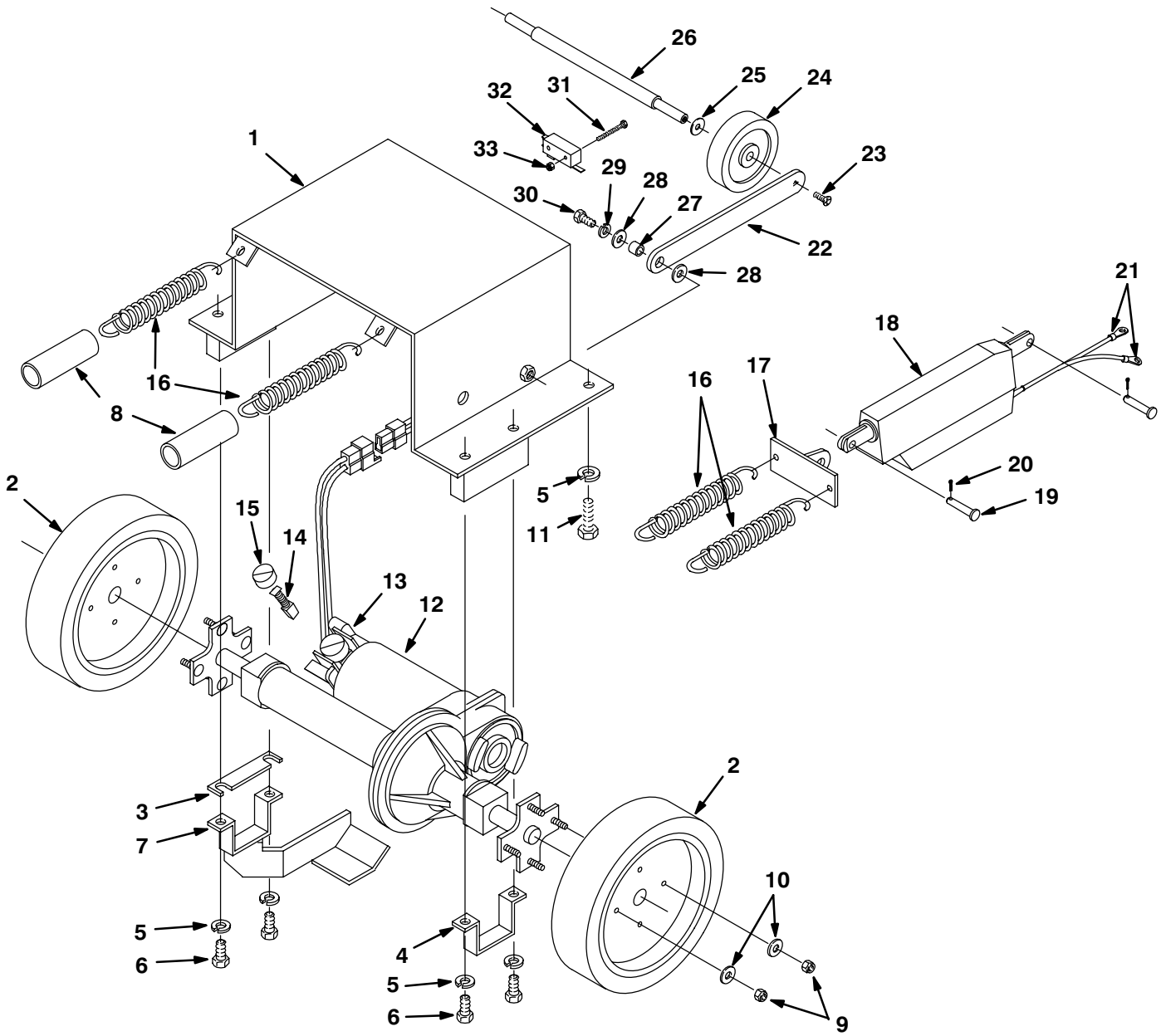



## DRIVE GROUP (Plus Model)

REF	PART #	DESCRIPTION	QTY.
1	603277	FRAME WELDMENT	1
2	640013	WHEEL, 8"DIA, 2"WIDE NEOPRENE	2
3	604293	SPACER, 3/4X4X1/16	1
4	602881	BRACKET, TRANSAXLE MTG	1
5	140333	WASHER, M10 SPLITLOCK	6
6	200031554	SCREW, HXHD M10X65	4
7	610130	MOUNT GUARD, TRANSAXLE	1
8	611023	SLEEVE, SPRING	2
9	630268	NUT, 1/4-28 HXLOCK	8
10	140000	WASHER, 1/4 FLAT	8
11	140277	SCREW, M10X1.50X20 HXHDCP	2
12	603450	TRANSAXLE, 36VDC	1
13	600606	END BELL, TRANSAXLE MOTOR	1
14	630504	●CARBON BRUSH (36V)	2
15	630503	●CAP, (36V)	2
16	140431	SPRING, EXT 1X.095X5	4
17	609450	BRACKET, SPRING	1

REF	PART #	DESCRIPTION	QTY.
18	600952	ACTUATOR	1
19	604076	PIN, CLEVIS 10X28MM	2
20	578421	PIN, COTTER	2
21	130133	TERMINAL	2
22	603267	PLATE, PIVOT ARM	2
23	069762098	SCREW, M6X1.0X16 FLTPHL	2
24	103066	WHEEL, 4"DIA X 1.5HUB X .50 GRAY	2
25	140045	WASHER, .510X1.25X.06 FLAT	2
26	603274	AXLE, REAR WHEELS	1
27	140144	BUSHING, .375X.500	2
28	140028	WASHER, 3/8 FLAT	4
29	140017	WASHER, 3/8 SPLITLOCK	2
30	140202	SCREW, 3/8-16X1 HXHDCP	2
31	140829	SCREW, 6-32X1 PANPHL	2
32	069764009	●SWITCH, SNAP 25A LEVER	1
33	140539	NUT, 6-32 KEP	2

● RECOMMENDED STOCK ITEMS

WHEEL GROUP (Standard Model)

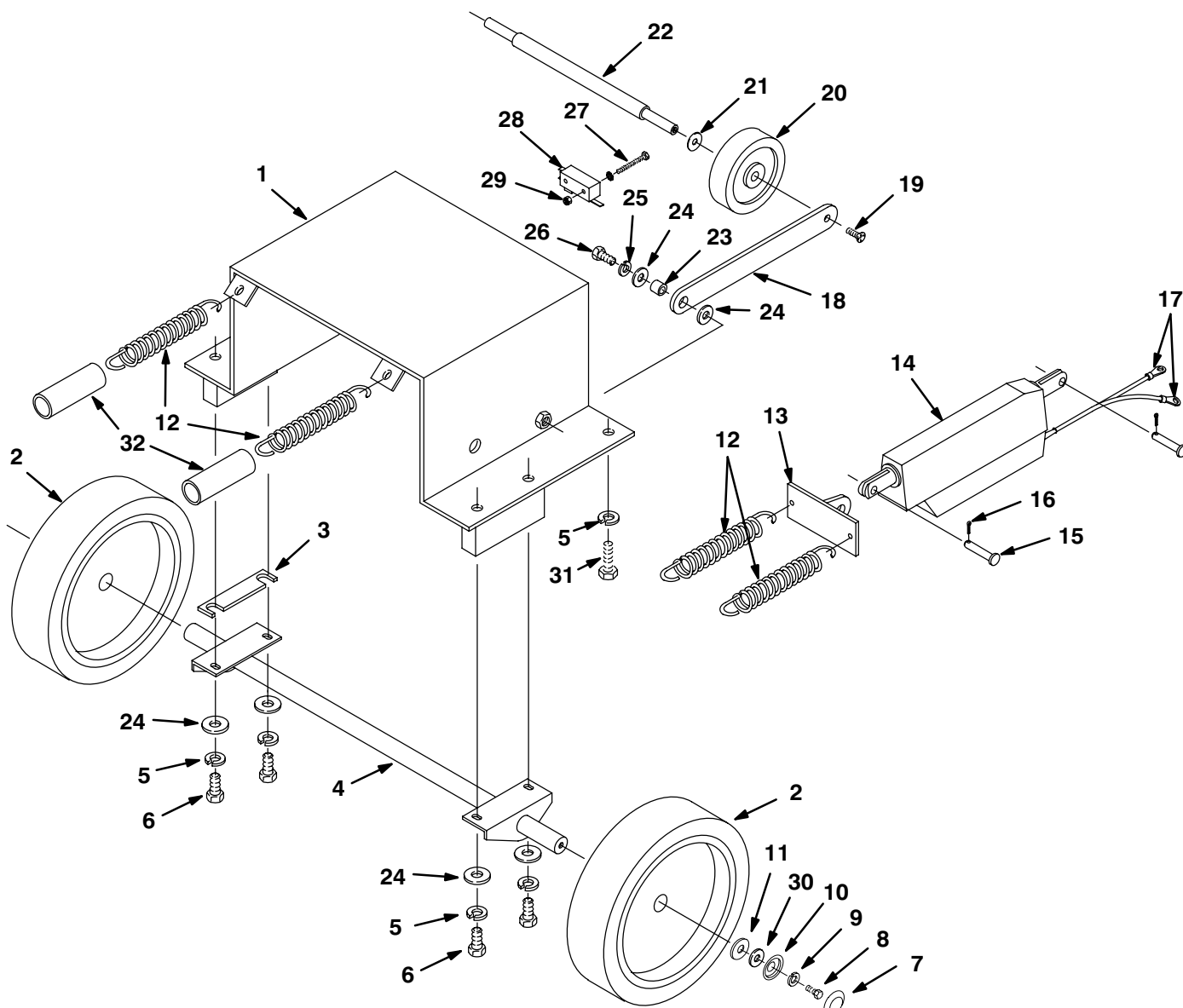

## WHEEL GROUP (Standard Model)

REF	PART #	DESCRIPTION	QTY.
1	603277	FRAME WELDMENT	1
2	605970	WHEEL, 8X1-5/8	2
	103071	BEARING, WHEEL REPLACEMENT	4
3	604293	SPACER, 3/4X4X1/16	1
4	603275	AXLE WELDMENT	1
5	140333	WASHER, M10 SPLITLOCK	6
6	200031554	SCREW, HXHD M10X65	4
7	150210	PLUG, CAP BLACK	2
8	140275	SCREW, M8X1.25X16 HXHDCP	2
9	140015	WASHER, 5/16 SPLITLOCK	2
10	140048	WASHER, 5/16 (FOR #150210)	2
11	140047	WASHER, 1.24X.754X.062	2
12	140431	SPRING, EXT 1.0X5	4
13	609450	BRACKET, SPRING	1
14	600952	ACTUATOR	1
15	604076	PIN, CLEVIS 10X28MM	2
16	578421	PIN, COTTER	2

REF	PART #	DESCRIPTION	QTY.
17	130133	TERMINAL	2
18	603267	PLATE, PIVOT ARM	2
19	069762098	SCREW, M6X1.0X16 FLTPHL	2
20	103066	WHEEL, 4"DIA X 1.5HUB X .50 GRAY	2
21	140045	WASHER, .510X1.25X.06 FLAT	2
22	603274	AXLE, REAR WHEELS	1
23	140144	BUSHING, .375X.500	2
24	140028	WASHER, 3/8 FLAT	8
25	140017	WASHER, 3/8 SPLITLOCK	2
26	140202	SCREW, 3/8-16X1 HXHDCP	2
27	140829	SCREW, 6-32X1 PANPHL	2
28	069764009	●SWITCH, SNAP 25A LEVER	1
29	140539	NUT, 6-32 KEP	2
30	140055	WASHER, FLAT .343X1.25X.057	2
31	140277	SCREW, M10X1.50X20	2
32	611023	SLEEVE, SPRING	2

## ● RECOMMENDED STOCK ITEMS

CONTROL CONSOLE GROUP (Plus Model)

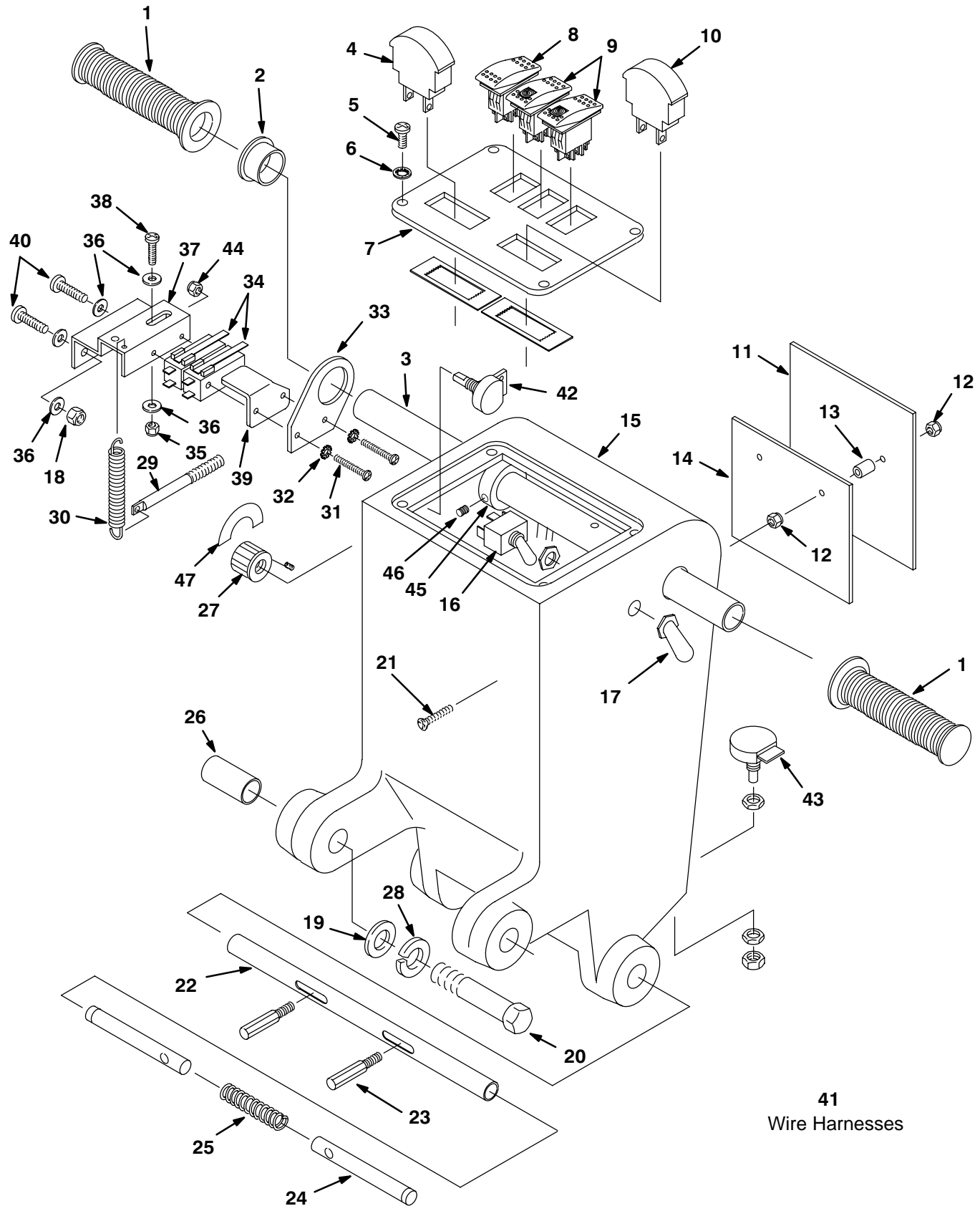

41  
Wire Harnesses

## CONTROL CONSOLE GROUP (Plus Model)

REF	PART #	DESCRIPTION	QTY.
1	200823	GRIP, HANDLE TUBE	2
2	605351	BUSHING	1
3	604402	HANDLE, TUBE	1
4	603848	GAUGE, PAD PRESSURE	1
5	578141000	SCREW, M5X10MM	4
6	140018	WASHER, LOCK	4
7	603757	PANEL, CONTROL	1
8	603399	●SWITCH, DPDT MOM ON/OFF	1
9	601107	●SWITCH, LIGHTED ROCKER	2
10	603847	METER, BATTERY VOLTAGE 36V	1
11	606529	●SPEED CONTROL, 36VDC, 40A	1
12	200160014	NUT, M4	4
13	630261	SPACER	2
14	630128	HEAT SINK	1
15	608299	HOUSING, CONTROL, GREEN	1
16	601108	●SWITCH, TOGGLE	1
17	130753	BOOT, SWITCH	1
18	140284	NUT, M6 NYLOCK	2
19	140045	WASHER, FLAT 1/2	2
20	140351	SCREW, M12X70MM	2
21	630304	SCREW, M4X35MM	2
22	230715	TUBE, HANDLE ADJUSTMENT	1
23	230649	PIN, HANDLE ADJUSTMENT	2
24	230710	PIN, HANDLE LOCK	2
25	140415	SPRING, LOCK PIN	1

▽ ASSEMBLY

▲ INCLUDED IN ASSEMBLY

● RECOMMENDED STOCK ITEMS

REF	PART #	DESCRIPTION	QTY.
26	140155	BUSHING	2
27	606550	KNOB, SPEED CONTROL	1
28	140024	WASHER, LOCK 1/2	2
29	602886	PIN, SPRING RETURN	1
30	605812	SPRING, EXTENSION	1
31	140830	SCREW, 6-32X1-5/8	2
32	140019	WASHER, LOCK #6	2
33	27098	BRACKET, SWITCH	1
34	130729	●SWITCH, ROLL	2
35	140552	NUT, 10-24 NYLOCK	1
36	140000	WASHER, FLAT 1/4	5
37	25671	MOUNT, SWITCH	1
38	140890	SCREW, 10-24X1/2	1
39	603830	PLATE, GUARD SWITCH	1
40	608322	SCREW, M6X16MM	2
▽ 41	602873	●HARNESS CONSOLE W/POT. (NOT SHOWN)	1
	606538	HARNESS, WIRE MAIN (NOT SHOWN)	1
	605840	WRAP, LOOM .75DIA, 1FT (NOT SHOWN)	1
▲ 42	130776	●POTENTIOMETER, 50K	1
▲ 43	130775	●POTENTIOMETER, 50K LOCK- ABLE	1
44	140540	NUT, 6-32 HEX STD	2
45	605094	COLLAR, HANDLE	2
46	140859	SET SCREW	2
47	606549	DECAL, SPEED CONTROL	1

# PARTS LIST

## CONTROL CONSOLE GROUP (Standard Model)

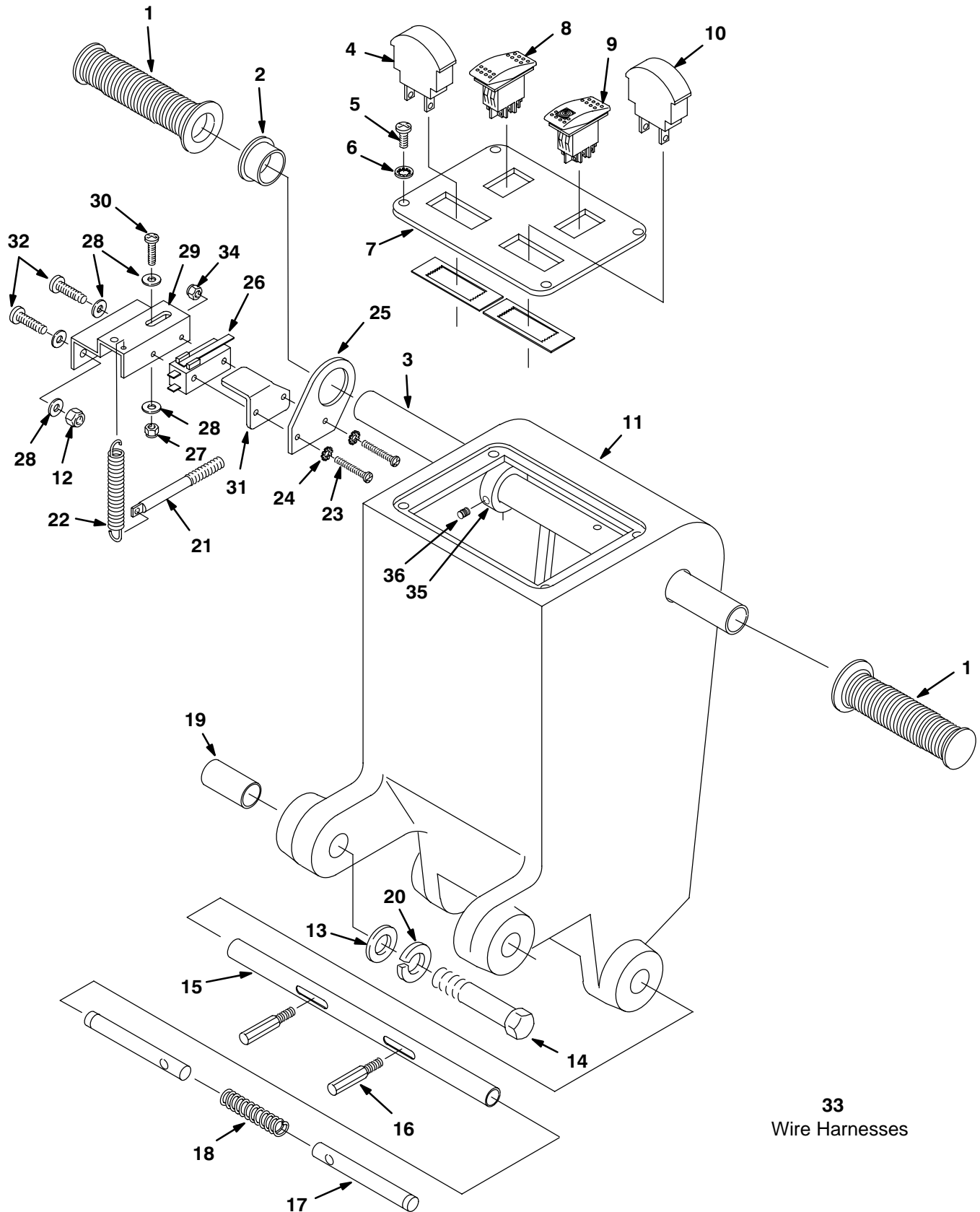

**33**  
Wire Harnesses

## CONTROL CONSOLE GROUP (Standard Model)

REF	PART #	DESCRIPTION	QTY.
1	200823	GRIP, HANDLE TUBE	2
2	605351	BUSHING	1
3	604402	HANDLE, TUBE	1
4	603848	GAUGE, PAD PRESSURE	1
5	578141000	SCREW, M5X10MM	4
6	140018	WASHER, LOCK	4
7	604269	PANEL, CONTROL	1
8	603399	●SWITCH, DPDT MOM ON/OFF	1
9	601107	●SWITCH, LIGHTED ROCKER	1
10	603847	METER, BATTERY VOLTAGE 36V	1
11	608524	HOUSING, CONTROL, GREEN	1
12	140284	NUT, M6 NYLOCK	2
13	140045	WASHER, FLAT 1/2	2
14	140351	SCREW, M12X70MM	2
15	230715	TUBE, HANDLE ADJUSTMENT	1
16	230649	PIN, HANDLE ADJUSTMENT	2
17	230710	PIN, HANDLE LOCK	2
18	140415	SPRING, LOCK PIN	1
19	140155	BUSHING	2

● RECOMMENDED STOCK ITEMS

REF	PART #	DESCRIPTION	QTY.
20	140024	WASHER, LOCK 1/2	2
21	602886	PIN, SPRING RETURN	1
22	605812	SPRING, EXTENSION	1
23	140829	SCREW, 6-32X1	2
24	140019	WASHER, LOCK #6	2
25	27098	BRACKET, SWITCH	1
26	130729	●SWITCH, ROLL	1
27	140552	NUT, 10-24 NYLOCK	1
28	140000	WASHER, FLAT 1/4	5
29	25671	MOUNT, SWITCH	1
30	140890	SCREW, 10-24X1/2	1
31	603830	PLATE, GUARD SWITCH	1
32	608322	SCREW, M6X16MM	2
33	606539	HARNESS, WIRE MAIN (NOT SHOWN)	1
	605840	WRAP, LOOM .75DIA, 1FT (NOT SHOWN)	2
34	140540	NUT, 6-32 HEX STD	2
35	605094	COLLAR, HANDLE	2
36	140859	SET SCREW	2

ELECTRICAL/BATTERY GROUP

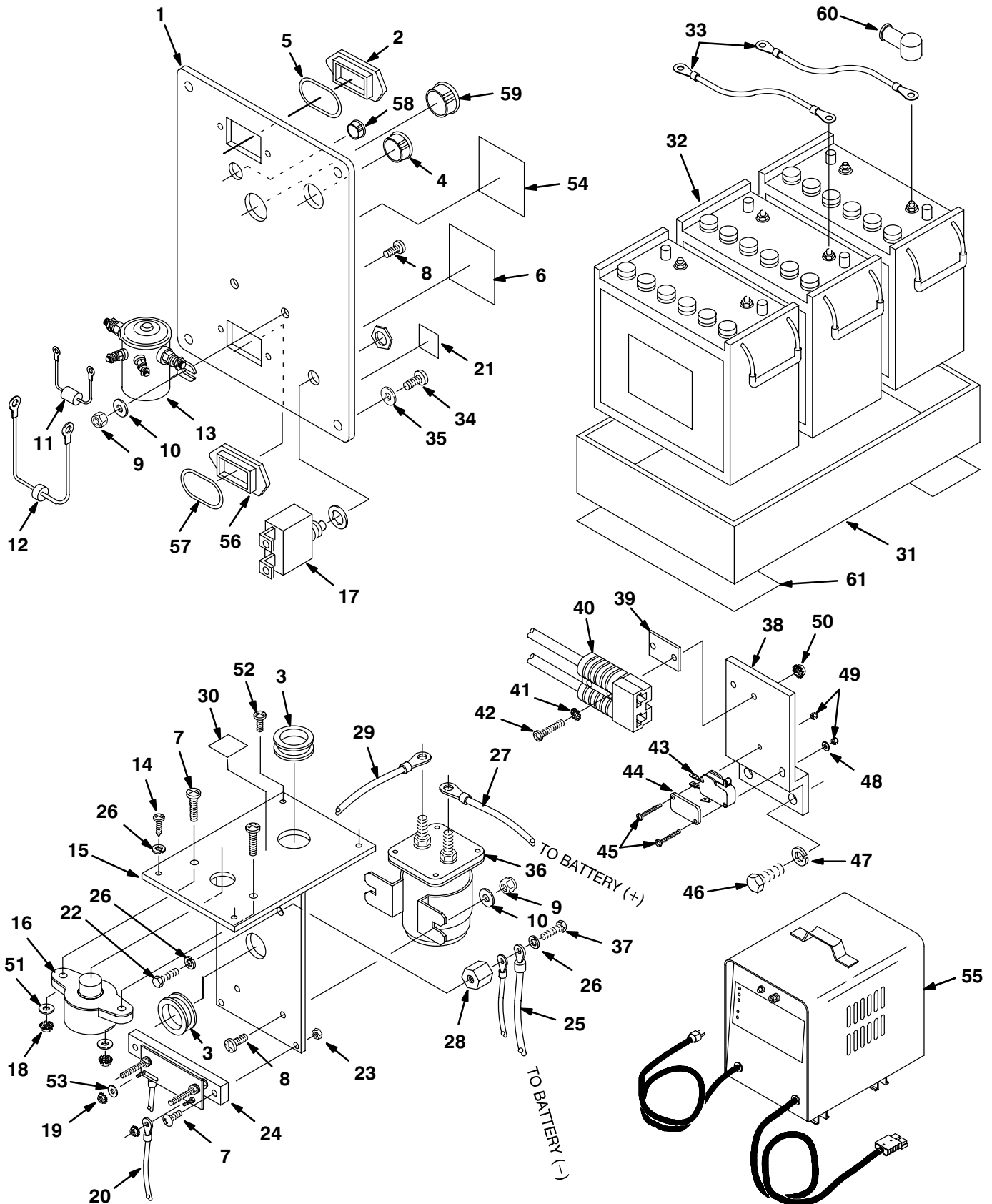



## ELECTRICAL/BATTERY GROUP

REF	PART #	DESCRIPTION	QTY.
1	604939	PANEL, CONTROL HOUSING	1
2	609969	PLUG	1
3	069762009	GROMMET, DIA 25.4X03	2
4	130175	PLUG, DOME .750	1
5	605823	O-RING	1
6	630420	DECAL, FLAMMABLE MATERIAL	1
7	578302000	SCREW, M5X26 PANPHL	4
8	608322	SCREW, M6X16MM	4
9	140284	NUT, M6 NYLOCK	4
10	140000	WASHER, FLAT 1/4	4
11	606404	●DIODE, 400V (PLUS MODEL)	1
12	604486	●DIODE, 400V (PLUS MODEL)	1
13	130733	●SOLENOID, 36V (PLUS MODEL)	1
14	578187000	SCREW, M6X1.0X12 PANPHL	3
15	604271	BRACKET, ELECTRICAL CHASSIS	1
16	130781	●BREAKER, CIRCUIT 80 AMP	1
17	603487	●BREAKER, CIRCUIT BRUSH 15A	1
18	140283	NUT, M5X.8 NYLOCK	2
19	140524	NUT, 1/4-20 KEP	2
20	604292	ASM, WIRE #4 BLK X 6"	1
21	604795	DECAL, MAIN BREAKER	1
22	140553	SCREW, 1/4-20X1/2 HXHDCP	1
23	140283	NUT, M5X.8 NYLOCK	2
24	605292	SHUNT	1
25	604290	ASM, WIRE #4 BLK X 27"	1
26	140016	WASHER, LOCK 1/4	5
27	604289	ASM, WIRE #4 RED X 46"	1
28	578427	STANDOFF, TERMINAL	1
29	604291	ASM, WIRE #4 BLK X 6"	1
30	604794	DECAL, PAD MOTOR CIRCIUT BREAKER	1
31	604298	TRAY, BATTERY	1

## ● RECOMMENDED STOCK ITEMS

REF	PART #	DESCRIPTION	QTY.
32	600394	BATTERY, 12V 215A (OPTIONAL)	3
33	611116000	CABLE, BATTERY #6 BLACKX15"	2
34	578141000	SCREW, M5X10	4
35	140018	WASHER, LOCK #10	4
36	621381000	●CONTACTOR	1
37	140553	SCREW, 1/4-20X1/2 HXHDCP	1
38	604270	BRACKET, CHARGER PLUG	1
39	603331	SPACER, CHARGER PLUG	1
40	604288	ASM., CABLE CHARGE PLUG	1
41	140019	WASHER, 36 EXT	2
42	140829	SCREW, 6-32X1 PANPHL	2
43	600437	●SWITCH, ROLLER 15A (PLUS MODEL)	1
44	601359	PLATE, SWITCH BACKING (PLUS MODEL)	1
45	578 403 000	SCREW, M3X20 PANPHL (PLUS MODEL)	2
46	578187000	SCREW, M6X1.0X12 PANPHL	2
47	140016	WASHER, 1/4 LOCK	2
48	601 127 000	WASHER, FLAT (PLUS MODEL)	1
49	579211	NUT, M3 HEXLOCK (PLUS MODEL)	2
50	140539	NUT, 6-32 KEP	2
51	140011	WASHER, 3/16 FLAT	2
52	140340	SCREW, #10X5/8 PANPHL	1
53	140026	WASHER, #6 FLAT	1
54	578729	DECAL, READ MANUAL	1
55	469760868	CHARGER, 36DC 25 AMP (OPTIONAL)	1
56	609969	PLUG	1
57	605823	O-RING	1
58	604940	PLUG, DOME	1
59	130161	PLUG, DOME .875	1
60	611221	BOOT, BATTERY, BLACK	3
60	611222	BOOT, BATTERY, RED	3
61	611022	GASKET, BATTERY TRAY	2

**HOUR METER, EMERGENCY STOP AND KEYSWITCH KITS**

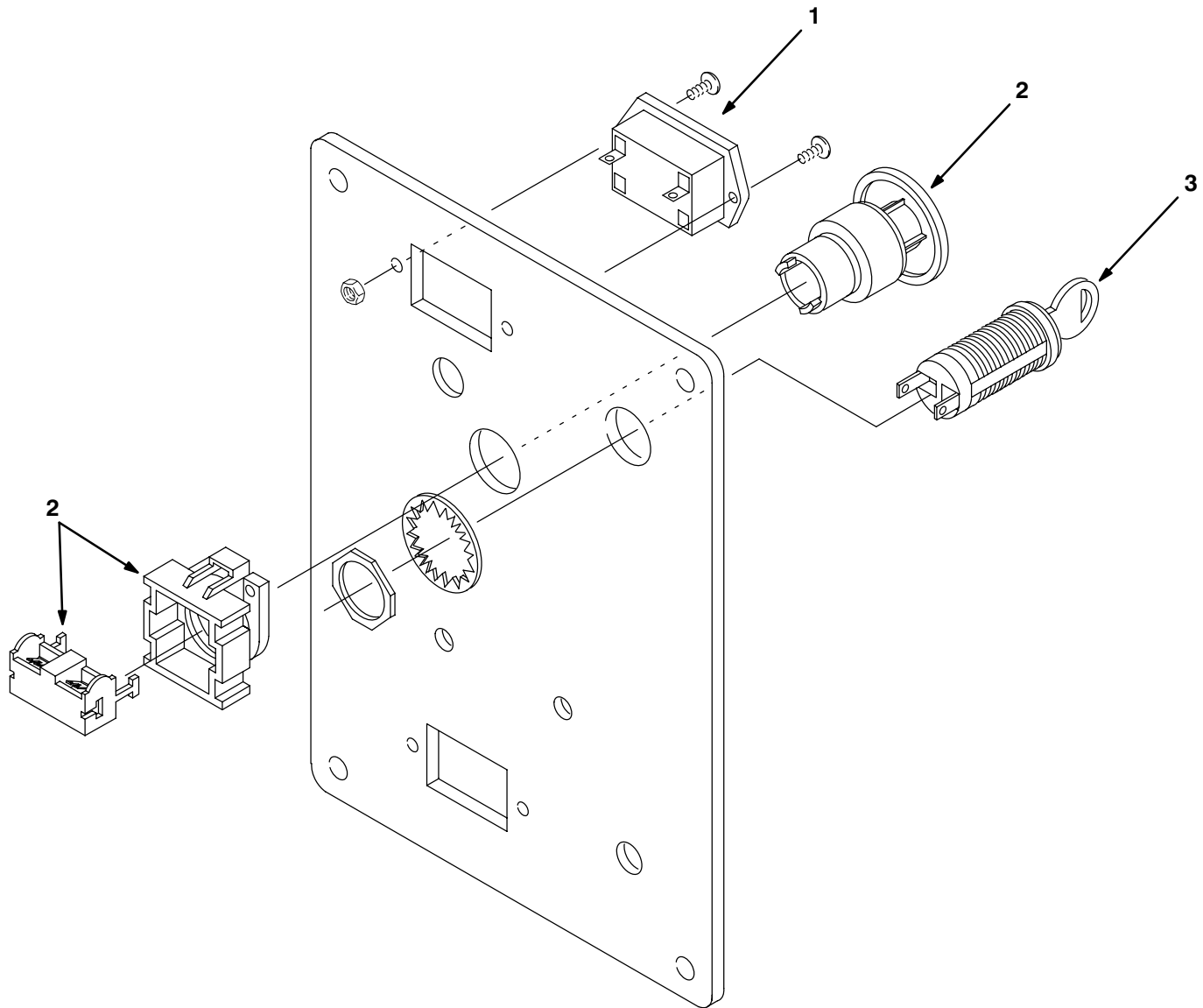

REF	PART #	DESCRIPTION	QTY.
▽ 1	604501	KIT, HOUR METER	1
▲	630143	HOUR METER	1
▲	603081	ASM., WIRE #18X12" RED	1
▲	604960	ASM., WIRE #18X9" BLACK W/ P-BACK. TER.	1
▲	603080	ASM., WIRE #18X8" BLACK W/ TERM. RING	1
▲	604643	ASM., WIRE #18X9" BLACK	1

REF	PART #	DESCRIPTION	QTY.
▽ 2	602995	KIT, EMERGENCY STOP	1
▲	630100	SWITCH, EMERGENCY STOP BUTTON	1
▲	630097	SWITCH, CONTACT BLOCK	1
▲	602996	ASM, WIRE #16X5" RED 1/4FX1/4F	1
▲	602997	ASM, WIRE #16X5" RED 1/4MX1/4F	1
▽ 3	602993	KIT, KEYSWITCH	1
▲	607475	KEYSWITCH	1
▲	607821	KEY, REPLACEMENT	1

▽ ASSEMBLY

▲ INCLUDED IN ASSEMBLY

**PARKING BRAKE KIT**

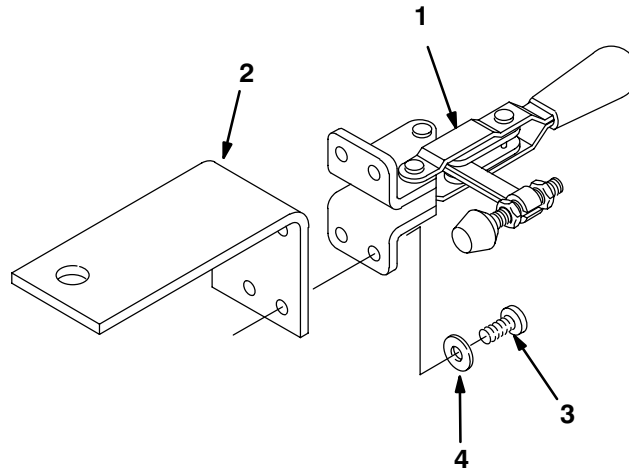

REF	PART #	DESCRIPTION	QTY.
▽	604502	KIT, PARKING BRAKE	1
▲ 1	600634	CLAMP, PARKING BRAKE	1

REF	PART #	DESCRIPTION	QTY.
▲ 2	603122	BRACKET, PARKING BRAKE	1
▲ 3	140887	SCREW, #10-24X3/8	4
▲ 4	140018	WASHER, #10	4

▽ ASSEMBLY

▲ INCLUDED IN ASSEMBLY

**FLASHING LIGHT KIT**

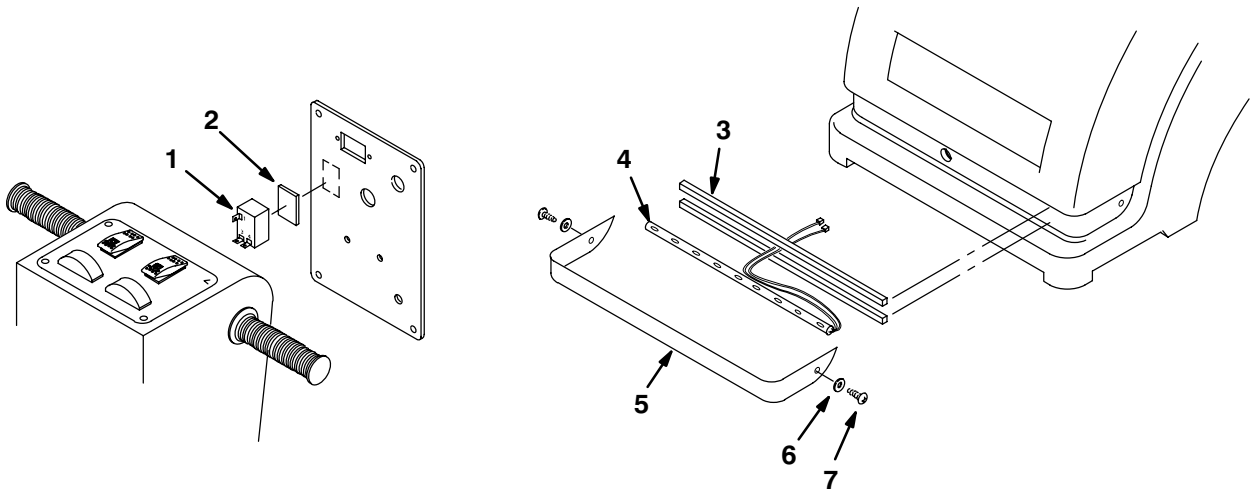

REF	PART #	DESCRIPTION	QTY.
▽	604500	KIT, FLASHING LIGHTS	1
▲ 1	603839	FLASHER, 36VDC	1
▲ 2	100058	TAPE, ACRYLIC FOAM	.08 FT.
▲ 3	606242	GASKET	1

REF	PART #	DESCRIPTION	QTY.
▲ 4	603440	LIGHT, SAFETY	1
▲ 5	600298	SHIELD, LIGHT	1
▲ 6	578186000	WASHER, FLAT	2
▲ 7	200070340	SCREW, M4X.7X8	2

▽ ASSEMBLY

▲ INCLUDED IN ASSEMBLY